

**TECHNICAL MANUAL**

**OPERATOR'S, UNIT, DIRECT SUPPORT, AND GENERAL SUPPORT  
MAINTENANCE MANUAL**

**FOR**

**SEMITRAILER, TANK: 5000 GALLON,  
BULK HAUL, SELF LOAD/UNLOAD  
M967 (NSN 2330-01 -050-5632)  
M967A1 (NSN 2330-01-1 55-0046)**

**SEMITRAILER, TANK: 5000 GALLON,  
FUEL DISPENSING, AUTOMOTIVE  
M969 (NSN 2330-01 -050-5634)  
M969A1 (NSN 2330-01-1 55-0048)**

**SEMITRAILER, TANK: 5000 GALLON,  
FUEL DISPENSING, UNDER/OVERWING AIRCRAFT  
M970 (NSN 2330-01 -050-5635)  
M970A1 (NSN 2330-01-155-0047)**

This manual and TM 9-2330-356-24P supersede TM 9-2330-356-12&P dated 20 October 1980 and TM 9-2330-356-34&P dated 1 October 1980 and all changes.

Approved for public release: distribution is unlimited.

---

**HEADQUARTERS, DEPARTMENT OF THE ARMY OCTOBER 1990**

FOR FIRST AID INFORMATION, REFER TO FM 21-11.

**WARNING**

If incorrectly used, this equipment can cause severe injury or death. Those who use and maintain the equipment should be trained in its proper use and warned of its dangers. Read manual before attempting to set up, operate, adjust, or service the equipment.

**WARNING**

Frequent inspection of equipment, safety devices, and working areas must be performed to ensure personal and operational safety and to correct potential or actual hazards.

**WARNING**

The semitrailer must not be operated if any of the following conditions exist:

- Fuel leaks.
- Damage to lighting fixtures, wiring, or electrical conduits or lights inoperative.
- Damage to towing vehicle or semitrailer.
- Primary or parking brake systems inoperative.
- Vents plugged, inoperative, or removed. Pressure, vacuum, and fusible vents are installed to meet code requirements and protect the semitrailer from damage. A plugged or inoperative vent can cause extensive shell damage if design pressure or vacuum is exceeded. The fusible vents are designed to operate at high temperatures. If these vents are coated with paint, dirt, or other foreign material, the temperature when relief occurs may be greatly increased.

**WARNING**

Dry cleaning solvent P-D-680 is toxic and flammable. Always wear protective goggles and gloves, and use only in a well-ventilated area. Avoid contact with skin, eyes, and clothes, and DO NOT breathe vapors. DO NOT use near open flame or excessive heat. The solvent's flash point is 100°F-138°F (38°C-59°C). If you become dizzy while using cleaning solvent, immediately get fresh air and medical help. If solvent contacts eyes, immediately wash your eyes with water and get medical aid.

**WARNING**

Compressed air used for drying or cleaning purposes must not exceed 30 psi (207 kPa). Wear protective clothing (goggles and gloves) and use caution to avoid injury to personnel.

**WARNING**

Carbon monoxide can be deadly, DO NOT operate engine in an enclosed area unless it is adequately ventilated.

**WARNING**

Carbon monoxide is a colorless, odorless, and deadly poisonous gas which occurs in the exhaust fumes of the auxiliary power engine. Exposure to air contaminated with carbon monoxide produces symptoms of headache, dizziness, loss of muscular control, apparent drowsiness, and coma. Permanent brain damage or death can result from severe exposure to carbon monoxide gas.

CHANGE

NO. 3

HEADQUARTERS  
DEPARTMENT OF THE ARMY  
Washington D.C., 3 June 1993

**OPERATOR'S, ORGANIZATIONAL, DIRECT SUPPORT, AND  
GENERAL SUPPORT MAINTENANCE MANUAL**

**SEMITRAILER, TANK: 5000 GALLON,  
BULK HAUL, SELF LOAD/UNLOAD  
M967 (NSN 2330-01-050-5632)  
M967A1 (NSN 2330-01-155-0046)**

**SEMITRAILER, TANK: 5000 GALLON,  
FUEL DISPENSING, AUTOMOTIVE  
M969 (NSN 2330-01-050-5634)  
M969A1 (NSN 2330-01-155-0048)**

**SEMITRAILER, TANK: 5000 GALLON,  
FUEL DISPENSING, UNDER/OVERWING AIRCRAFT  
M970 (NSN 2330-01-050-5635)  
M970A1 (NSN 2330-01-155-0047)**

Current as of

TM 9-2330-356-14, October 1990, is changed as follows:

1. Remove old pages and insert new pages.
2. New or changed material is indicated by a vertical bar in the margin and by a vertical bar adjacent to the TA number.

Remove Pages

1-13 and 1-14  
2-3 and 2-4  
3-3 thru 3-14  
3-17 thru 3-20  
4-11 thru 4-14  
4-73 thru 4-94  
4-99 thru 4-110  
5-13 thru 5-22  
6-1 thru 6-6  
E-3 and E-4  
Index 1 thru Index 6  
Index 13 thru Index 16

Insert Pages

1-13 and 1-14  
2-3 and 2-4  
3-3 thru 3-14  
3-17 thru 3-20  
4-11 thru 4-14  
4-73 thru 4-94  
4-99 thru 4-110  
5-13 thru 5-22  
6-1 thru 6-6  
E-3 and E-4  
Index 1 thru Index 6  
Index 13 thru Index 16

File this change sheet in front of the publication for reference purposes.

**Approved for public release; distribution unlimited.**

By Order of the Secretary of the Army:

GORDON R. SULLIVAN  
*General, United States Army*  
*Chief of Staff*

Official:

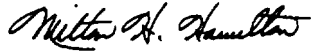

MILTON H. HAMILTON  
*Administrative Assistant to the*  
*Secretary of the Army*  
04475

Distribution:

To be distributed in accordance with DA Form 12-39-E, Block 0788, requirements for  
TM 9-2330-356-14.



CHANGE

NO. 2

HEADQUARTERS  
DEPARTMENT OF THE ARMY  
Washington D.C., 1 June 1993

**OPERATOR'S, ORGANIZATIONAL, DIRECT SUPPORT, AND  
GENERAL SUPPORT MAINTENANCE MANUAL**

**SEMITRAILER, TANK: 5000 GALLON,  
BULK HAOU, SELF LOAD/UNLOAD**

**M967 (NSN 2330-01-050-5632)**

**M967A1 (NSN 2330-01-155-0046)**

**SEMITRAILER, TANK: 5000 GALLON,  
FUEL DISPENSING, AUTOMOTIVE**

**M969 (NSN 2330-01-050-5634)**

**M969A1 (NSN 2330-01-155-0048)**

**SEMITRAILER, TANK: 5000 GALLON,  
FUEL DISPENSING, UNDER/OVERWING AIRCRAFT**

**M970 (NSN 2330-01-050-5635)**

**M970A1 (NSN 2330-01-155-0047)**

Current as of

TM 9-2330-356-14, October 1990, is changed as follows:

1. Remove old pages and insert new pages.
2. New or changed material is indicated by a vertical bar in the margin of the page.

Remove Pages

4-109 and 4-110

Insert Pages

4-109 and 4-110

3. File this change sheet in front of the publication for reference purposes.

Approved for public release; distribution unlimited.

By Order of the Secretary of the Army:

GORDON R. SULLIVAN  
*General, United States Army*  
*Chief of Staff*

Official:

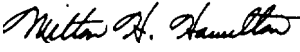
  
MILTON H. HAMILTON  
*Administrative Assistant to the*  
*Secretary of the Army*  
04471

Distribution:

To be distributed in accordance with DA Form 12-39 requirements for TM 9-2330-356-14.

ARMY

HEADQUARTERS  
DEPARTMENT OF THE ARMY  
Washington D.C., 26 June 1992

**Operator's, Unit, Direct Support and General Support  
Maintenance Manual**

**For**

**Semitrailer, Tank: 5000 Gallon  
Bulk Haul, Self-Load/Unload  
M967 (NSN 2330-01450-5632)  
M967A1 (NSN 2330-01-155-0046)**

**Semitrailer, Tank: 5000 Gallon  
Fuel Dispensing, Automotive  
M969 (NSN 2330-01-050-5634)  
M969A1 (NSN 2330-01-155-0048)**

**Semitrailer, Tank: 5000 Gallon  
Fuel Dispensing, Under/Overwing Aircraft  
M970 (NSN 2330-01-050-5635)  
M970A1 (NSN 2330-01-155-0047)**

TM 9-2330-356-14, 26 October 1990, is changed as follows:

1. Remove old pages and insert new pages.
2. New or changed material is indicated by a vertical bar in the margin of the page.

**Remove Pages**

f through h/ (i Blank)

2-5 and 2-6

2-19 and 2-20

4-101 and 4-402

4-115 and 4-116

8-15 and 8-16

**Insert Pages**

f through h/ (i Blank)

2-5 and 2-6

2-19 and 2-20

4-101 and 4-402

4-115 and 4-116

8-15 and 8-16

3. File this change sheet in front of the publication for reference purpose.

**Approved for public release; distribution is unlimited.**

By Order of the Secretary of Army

GORDON R. SULLIVAN  
*General, United States Army*  
*Chief of Staff*

Official:

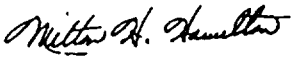
  
MILTON H. HAMILTON  
*Administrative Assistant to the*  
*Secretary of the Army*  
01789

Distribution:

To be distributed IAW DA Form 12-39-E (block 788), Operator, Unit, Direct Support and General Support maintenance requirements for TM9-2330-356-14.

---

**WARNING**

---

Be sure that grounding connections are made properly and firmly before any fueling operations begin. This will ensure that grounding connections will not release, thus eliminating the possibility of sparks caused by static electricity which will ignite the fuel. This applies to top loading and bottom loading at a fixed loading facility. Bottom loading is the preferred method when facilities are available.

---

**WARNING**

---

Grounding cable must be connected before any servicing operations. The first clip should be attached to the ground rod. The second clip should be attached to the aircraft grounding fitting, if one is provided, or to a convenient unpainted metal point on the aircraft. Grounding should not be made to a propeller, radio antenna, or highly stressed components of the landing gear where scratches could cause metal failure. Always disconnect the grounding clips in reverse order, first the aircraft, then the ground rod. The grounding cables shall be disconnected only after fuel servicing operations have been completed and all dispensing nozzles and hoses have been disconnected or removed from filler openings and stowed on the refueling vehicle. Grounding cables attached to dispensing nozzles maybe disconnected only after nozzles have been disconnected or removed from filler openings of aircraft being serviced.

---

**WARNING**

---

#### GROUND AIRCRAFT OR VEHICLE TO SEMITRAILER

Grounding of the semitrailer to aircraft or vehicle while refueling is mandatory, regardless of the amount of fuel to be dispensed, due to the dangers of static electricity.

Bond the fuel nozzle to the aircraft before opening the filler cap. Connect closed circuit nozzles securely before beginning fuel flow. Electrical hazards may be introduced in several ways, such as:

- Electrostatic sparks.
- Operating aircraft engines, auxiliary power units and heaters.
- Operating automotive or other internal combustion engines servicing equipment in the vicinity.
- Arcing of electrical circuits.
- Open flames.
- Energy from energized equipment.
- Lightning.

---

**WARNING**

---

Before performing maintenance on semitrailer, semitrailer must be grounded to an approved (earth) ground and it must be safe to proceed. Failure to follow this warning may cause a spark to ignite, resulting in serious injury or death to personnel.

---

**WARNING**

---

DO NOT let go of static reel cable when rewinding until ball stop is firmly touching the reel. Failure to follow this warning may cause injury to personnel.

**WARNING**

DO NOT paint the semitrailer's grounding studs. To ensure safe operation of fuel handling equipment, proper bonding and grounding connections must be made to clean, unpainted surfaces. Failure to follow this warning may result in injury or death to personnel.

**WARNING**

Follow all fuel handling procedures precisely to prevent injury or death to personnel,

**WARNING**

All fueling/defueling operations must be performed outside.

**WARNING**

Should an emergency arise requiring entry into a tank which is not vapor-free, or which has an oxygen content less than 19.5%, personnel who enter tank shall have an attached lifeline and wear protective respiratory equipment in the form of either a self-contained breathing apparatus or a full facepiece with a pressure supply of respirable air. Another person also provided with respiratory equipment shall be stationed at the manhole opening and remain thereto watch personnel in the tank and to summon assistance if a rescue operation becomes necessary. Personnel SHOULD NOT enter a tank which is in the explosive range.

**WARNING**

Before and after all fuel servicing operations, all valves are to be in the closed position. Failure to follow this warning could result in excessive spillage and create a fire hazard.

**WARNING**

DO NOT permit automotive equipment, other than that performing the fuel servicing functions, to be within 50-feet of the aircraft during fuel servicing operations.

**WARNING**

When semitrailer is emptied of fuel, a mixture of vapor and air remains that maybe, and often is, within the flammable range. Refilling the trailer with a different type of fuel other than it originally contained can cause a potential explosive atmosphere within the trailer. Know what fuel was previously carried so t hat preventive measures may be taken to ensure that injurious or explosive fumes are not released. Failure to follow this warning may result in serious injury or death to personnel.

**WARNING**

DO NOT fuel aircraft with any of its engines running. Fire could result.

**WARNING**

DO NOT attempt aircraft fueling operations if combustion heaters (e.g., wing and tail surface heater, integral cabin heaters) are being operated on the aircraft.

---

**WARNING**

---

When filling tank by means of bottom loading, defueling (M970 or M970A1), or self-loading, a test of the precheck system is mandatory. If this system is not functioning, stop all operations. Determine the problem and have it corrected by a qualified technician. Failure of automatic shutoff to function may result in uncontrolled fuel spillage and danger of fire and explosion.

---

**WARNING**

---

When top loading through fill cover, there is no automatic shutdown. Man the loading hose to avoid fuel spillage. Use capacity indicator gage and dipstick gage to determine amount of fuel loaded. Failure to follow this warning may result in uncontrolled fuel spillage and a fire or explosion hazard.

---

**WARNING**

---

DO NOT mix incompatible fuels in tank. Dangerous fumes and explosion may result. Know what fuel was previously carried so that preventive measures may be taken to ensure that injurious or explosive fumes are not released. Failure to follow this warning may result in injury or death to personnel.

---

**WARNING**

---

In an emergency, close valve A or pull emergency valve shutoff on opposite side of semitrailer.

---

**WARNING**

---

Operators must be alert for leaking or malfunctioning equipment. Stop all servicing operations immediately at the first sign of leaks or malfunctions. Corrective action must be performed by qualified technicians before resuming any operations.

---

**WARNING**

---

Parking areas for fuel servicing vehicles should be arranged to:

- Facilitate dispersal of vehicles in event of an emergency.
- Provide at least 10-feet of clear space between vehicles for accessibility for fire control purposes.
- Prevent any vehicle from draining into an adjacent building.
- Provide at least 50-foot distance from any structure housing the public, that may have windows or doors in exposed walls.

---

**WARNING**

---

All vapor-freeing work by any method should be carried on outdoors, remote from vehicles and other known sources of ignition, and the tank unit must be stationed where flammable vapors will not blow or drift indoors. Failure to follow this warning may result in serious injury or death to personnel.

---

**WARNING**

---

Combustible vapor testing must be conducted as prescribed in this manual and current technical bulletins and field manuals. Vapor testing should not be conducted during steam cleaning since excess moisture or lack of oxygen may cause false readings.

**WARNING**

Servicing the semitrailer when connected to the towing vehicle, regardless of the nature of the repair, the following should be done:

- The tractor engine should be shut down.
- The tractor parking brakes should be applied.
- The tractor ignition key should be removed and in the hands of the operating technician, or locked in an area away from the vehicle.

**WARNING**

Before performing repairs to these semitrailers involving welding, torching, grinding, chipping, or any other operation that would possibly create a spark, a thorough purging of all components in contact with the product or vapors is a must. All components that cannot be cleaned must be removed from unit; all gages should be removed before purging. A meter check for any combustion material after purging must be made before performing any work, and every 2 hours after that.

**WARNING**

The following steps must be followed if semitrailer is to be moved to the inside of a building:

1. Drain tank completely and purge.
2. Check interior of tank with explosive meter prior to moving into building.
3. Use explosive meter to check tank prior to starting work each day and perform random checks during the day.
4. No open flames, welding, or use of heat producing devices permitted near tank during maintenance unless tank tests safe with explosive meter.
5. No smoking within 50-feet of vehicle at any time.

**WARNING**

DO NOT climb into tank unless interior of tank has been drained and purged and an explosive meter check indicates that it is safe to do so. Adequate forced air ventilation or self-contained breathing apparatus must be used. Person entering tank must have an attached lifeline. An observer must be stationed at the manhole opening so that assistance maybe summoned in the event of an emergency. Failure to follow this warning may result in serious injury or death to personnel.

**WARNING**

When troubleshooting an electrical malfunction or performing electrical maintenance, ALWAYS disconnect intervehicular electrical cable from semitrailer, and negative battery cables at batteries. Failure to follow this warning may create a spark and explosion, resulting in serious injury and death to personnel.

**WARNING**

Batteries produce explosive gases. Keep sparks, flame, and smoking material away. Ventilate when charging or using in an enclosed space. The batteries contain sulfuric acid that causes severe burns. If acid contacts eyes, skin, or clothing, flush well with water. For contact with eyes, get immediate medical attention. Do not jump start engine. Batteries must be removed for recharging.



**WARNING**

115-220 volts can cause personal or death. Take extreme care when working with this much voltage.

**WARNING**

Check for fuel leaks at gage tube connections before performing electrical testing at control panel. Stop any leaks and wipe up spills..

**WARNING**

Hose reel cabinet door on M970 and M970A1 is heavy-use two hands when opening and closing. Use latches to lock door. DO NOT slam.

**WARNING**

The M970 and M970A1 Hose reel cabinet door is spring loaded. Hold firmly when opening or closing.

**WARNING**

With hose pulled from hose reel, the reel is under spring tension. To avoid movement of hose feel by accidental activation of hose reel rewind switch, tighten hose reel lock. Failure to follow this warning may result in personal injury.a

**WARNING**

Use extreme caution when operating electric rewind on hose reels. NEVER use the electric rewind on both hose reels at the same time. Electric rewind should be halted, then resumed carefully as the fuel dispensing nozzle approaches the vehicle. As the hose becomes fully wound on the hose reel, the nozzle may slam against the vehicle with force sufficient to cause injury to persons and/or damage to equipment. Extreme care is to be used, ensuring that the hose is rewound slowly. Caution should be used at the hose reels to prevent accidental tripping of the rewind switches. If these are accidentally depressed by hand or by falling objects, serious injury to persons and/or damage to equipment may occur.

**WARNING**

DO NOT attempt to repair brake chamber fail-safe unit. It is dangerous because of high spring compression. No repair is authorized for fail-safe unit.

**WARNING**

The fail-safe brake chamber power spring must be manually compressed and the air reservoirs must be vented of pressure before removal of hub and drum assembly.

**WARNING**

DO NOT crawl underneath, on top, or near the tires of the vehicle unless the brakes are positively locked and all other people are swam of your presence.

**WARNING**

Release air pressure from both air reservoirs before doing any work on brake lines or other pressurized areas.

**WARNING**

Due to asbestos hazard, do not grind off brake lining rivet heads. Failure to follow this warning may result in serious injury or death to personnel.

**WARNING**

Operators must wear ear protection while on engine side of semitrailer with engine running. Failure to follow this warning may result in injury to personnel.

**WARNING**

Handle charged fire extinguisher cylinders with care. DO NOT jar or expose to temperature above 140°F (60°C).

**WARNING**

Drain semitrailer tank completely before removing the emergency valve, recirculation adapter, or adapter plate. Excessive spillage would occur when these items are removed.

**WARNING**

When adjusting needle valve on 4-inch control valve, do not close needle valve completely. This will prevent 4-inch control valve from closing at any time during bottom load operations.

**WARNING**

Spare tire and wheel weighs 190 pounds. Four-person lift, or suitable lifting device, is required.

**WARNING**

The alternator weighs approximately 25 pounds. Use caution when removing or installing the alternator to avoid injury to personnel or damage to components.

**WARNING**

If the spring assembly is seized in spring seat, hack the rear axle higher to lift the spring. Be careful not to lift semitrailer off the supports under the frame.

**WARNING**

Ensure that forklift is properly positioned under cabinet. The entire weight of the cabinet is now on the forklift. Failure to follow this warning may result in cabinet falling and injuring personnel.

**WARNING**

DO NOT use acetylene torch to fuse emergency valve control cable ends unless tank has been cleaned and purged. Failure to follow this warning may result in serious injury or death to personnel.

**WARNING**

DO NOT allow nozzle spray to contact skin. Diesel fuel under pressure can penetrate flesh and cause serious injury and infection.

**WARNING**

Be careful when removing the impeller from the centrifugal pump. The spring load on the mechanical seal may cause the impeller to fly off the shaft as it is being removed, causing serious injury to personnel.

**WARNING**

Ladder has narrow tread. Use care when climbing. Failure to follow this warning may result in serious injury or death to personnel.



TECHNICAL MANUAL  
NO. 9-2330-356-14

HEADQUARTERS  
DEPARTMENT OF THE ARMY  
Washington D.C., 26 October 1990

**OPERATOR'S, UNIT, DIRECT SUPPORT, AND GENERAL SUPPORT  
MAINTENANCE MANUAL**

**FOR**

**SEMITRAILER, TANK: 5000 GALLON,  
BULK HAUL, SELF-LOAD/UNLOAD  
M967 (NSN 2330-01-050-5632)  
M967A1 (NSN 2330-01-155-0046)**

**SEMITRAILER, TANK: 5000 GALLON,  
FUEL DISPENSING, AUTOMOTIVE  
M969 (NSN 2330-01-050-5634)  
M969A1 (NSN 2330-01-155-0048)**

**SEMITRAILER, TANK: 5000 GALLON,  
FUEL DISPENSING, UNDER/OVERWING AIRCRAFT  
M970 (NSN 2330-01-050-5635)  
M970A1 (NSN 2330-01-155-0047)**

**REPORTING ERRORS AND RECOMMENDING IMPROVEMENTS**

You can help improve this manual. If you find any mistakes, or if you know of a way to improve the procedures, please let us know. Mail your letter, DA Form 2028 (Recommended Changes to Publications and Blank Forms), or DA Form 2028-2 located in the back of this manual direct to: Commander, U.S. Army Tank-Automotive Command, ATTN: AMSTA-MB, Warren, MI 48397-5000. A reply will be furnished to you.

**TABLE OF CONTENTS**

	Paragraph	Page
<b>Chapter 1. INTRODUCTION</b>		
Section I. General . . . . .	1-1	1-1
II. Description and Data . . . . .	1-7	1-1
<b>Chapter 2. OPERATING INSTRUCTIONS</b>		
Section I. Operating Procedures . . . . .	2-1	2-1
II. Operation of Auxiliary Equipment . . . . .	2-8	2-5
III. Operation Under Unusual Conditions . . . . .	2-20	2-53

• This manual and TM 9-2330-356-24P supersede TM 9-2330-356-12&P dated 20 October 1980 and TM 9-2330-356-34&P dated 1 October 1980 and all changes.

**TABLE OF CONTENTS - Continued**

	Paragraph	Page
<b>Chapter 3. OPERATOR/CREW MAINTENANCE INSTRUCTIONS</b>		
Section I. Lubrication Instructions . . . . .	3-1	3-1
II. Preventive Maintenance Checks and Services (PMCS) . . . . .	3-2	3-21
III. Troubleshooting . . . . .	3-4	3-28
IV. Maintenance Procedures . . . . .	3-5	3-34
<b>Chapter 4. UNIT MAINTENANCE INSTRUCTIONS</b>		
Section I. Service Upon Receipt of Material . . . . .	4-1	4-1
II. Repair Parts, Special Tools, and Equipment . . . . .	4-2	4-2
III. Preventive Maintenance Checks and Services (PMCS) . . . . .	4-5	4-5
IV. Unit Troubleshooting . . . . .	4-6	4-9
V. Painting and Stenciling . . . . .	4-7	4-22
VI. Testing the Electrical System with a Multimeter . . . . .	4-8	4-29
VII. Maintenance of Chassis Electrical System . . . . .	4-12	4-36
VIII. Maintenance of Engine Electrical Wiring . . . . .	4-16	4-45
IX. Maintenance of Engine Control Panel . . . . .	4-24	4-59
X. Maintenance of Hose Reel Electrical System . . . . .	4-27	4-68
XI. Maintenance of Bogie Assembly . . . . .	4-28	4-73
XII. Maintenance of Brake System . . . . .	4-31	4-74
XIII. Maintenance of Wheels, Hubs, and Drums . . . . .	4-49	4-101
XIV. Maintenance of Frame and Towing Attachments . . . . .	4-51	4-110
XV. Maintenance of Tank Body Parts . . . . .	4-56	4-114
XVI. Maintenance of Body Accessory Items . . . . .	4-62	4-120
XVII. Maintenance of Engine . . . . .	4-69	4-121
XVIII. Maintenance of Filter/Separator and Sump Components (M969, M969A1, M970, and M970A1) . . . . .	4-83	4-139
XIX. Maintenance of Dispensing Equipment . . . . .	4-85	4-141
XX. Draining and Purging of Tank Interior . . . . .	4-99	4-166
XXI. Preparation for Storage or Shipment . . . . .	4-104	4-170
<b>Chapter 5. DIRECT SUPPORT AND GENERAL SUPPORT MAINTENANCE INSTRUCTIONS</b>		
Section I. Repair Parts, Special Tools and Equipment . . . . .	5-1	5-1
II. Direct Support and General Support Troubleshooting . . . . .	5-4	5-3
III. General Maintenance . . . . .	5-7	5-11
IV. Removal and Installation of Major Components . . . . .	5-10	5-14
<b>Chapter 6. REPAIR OF FRAME AND BODY PARTS</b>		
Section I. General . . . . .	6-1	6-1
II. Body Assembly and Suspension . . . . .	6-3	6-1

## TABLE OF CONTENTS - Continued

		Paragraph	Page
III.	Brakes and Brake System Components . . . . .	6-6	6-4
IV.	Frame and Body Parts . . . . .	6-11	6-7
<b>Chapter 7.</b>	<b>REPAIR OF ENGINE ASSEMBLY</b>		
Section I.	Description and Specifications . . . . .	7-1	7-1
II.	Removal and Installation of Major Components . . . . .	7-11	7-10
III.	Repair Instructions . . . . .	7-61	7-36
IV.	Test and Adjustments . . . . .	7-80	7-62
<b>Chapter 8.</b>	<b>REPAIR OF PUMP, VALVES, AND DISPENSING EQUIPMENT</b>		
Section I.	General . . . . .	8-1	8-1
II.	Centrifugal Pumps . . . . .	8-3	8-1
III.	Hose Reels . . . . .	8-5	8-7
IV.	Meters . . . . .	8-7	8-15
V.	Emergency Valve Vent and Float Assembly . . . . .	8-8	8-16
VI.	Valves . . . . .	8-10	8-20
VII.	Nozzles and Couplings . . . . .	8-22	8-33
<b>Appendix A.</b>	<b>REFERENCES . . . . .</b>		A-1
<b>Appendix B.</b>	<b>MAINTENANCE ALLOCATION CHART . . . . .</b>		B-1
<b>Appendix C.</b>	<b>COMPONENTS OF END ITEM AND BASIC ISSUE ITEMS LISTS . . . . .</b>		C-1
<b>Appendix D.</b>	<b>ADDITIONAL AUTHORIZATION LIST . . . . .</b>		D-1
<b>Appendix E.</b>	<b>EXPENDABLE/DURABLE SUPPLIES AND MATERIALS LIST . . . . .</b>		E-1
<b>Appendix F.</b>	<b>TORQUE LIMITS . . . . .</b>		F-1
	Index . . . . .		Index 1





## CHAPTER 1 INTRODUCTION

---

### Section I. GENERAL

#### 1-1. Scope

This manual is for your use in operating and maintaining the M967, M967A1, M969, M969A1, M970, and M970A1 5000 gallon fuel tank semitrailers. It also includes references, components of end item lists, an additional authorization list, a maintenance allocation chart, and an expendable supplies and materials list.

#### 1-2. Maintenance Forms and Records

Equipment maintenance forms and procedures for their use are contained in DA Pam 738-750, The Army Maintenance Management System (TAMMS).

#### 1-3. Preparation for Storage or Shipment

For information on preparing the M967, M967A1, M969, M969A1, M970, and M970A1 semitrailers for storage or shipment, refer to Chapter 4, Section XXI.

#### 1-4. Destruction of Army Materiel to Prevent Enemy Use

Refer to TM 750-244-6 for information and instructions on destroying this equipment.

#### 1-5. Reporting of Equipment Improvement Recommendations (EIRs)

If your semitrailer needs improvement, let us know. Send us an EIR. You, the user, are the only one who can tell us what you don't like about your equipment. Let us know why you don't like the design. Tell us why a procedure is hard to perform. Put it on an SF 368 (Quality Deficiency Report). Mail it to: Commander, U.S. Army Tank-Automotive Command, ATTN: AMSTA-MP, Warren, MI 48397-5000. A reply will be furnished to you.

#### 1-6. Quality Assurance/Quality Control (QA/QC)

Quality assurance inspections shall be performed in accordance with requirements in TM 750-245-4.

### Section II. DESCRIPTION AND DATA

#### 1-7. Description (Figs. 1-1 through 1-11)

*a. Basic Configuration.* These trailers are designed to bestowed by a truck tractor equipped with a fifth wheel. Authorized 5-ton truck tractors are the M52A2, M818, M931, M931A1, M932, and M932A1. When driving on hard surface highways only, the 10-ton military-adapted commercial 6 x 4 truck tractors, M915 and M915A1, are also authorized. Construction and basic configuration of the M967, M967A1, M969, M969A1, M970, and M970A1 are the same except for dispensing equipment, new bogie, braking system, and functional use.

*b. Common Operations.* All six models, M967, M967A1, M969, M969A1, M970, and M970A1 can be loaded through the bottom or through the top fill opening. The 4-cylinder diesel engine and pump assembly provide self-load/unload capability.

*c. Construction.* The trailer has a stainless steel, single compartment tank of 5000 gallon capacity, plus 3% capacity for product expansion. The chassis is constructed of welded steel and is equipped with full floating tandem axles and manually operated landing gear.

*d. Common Equipment.* Each model is equipped with pressure and vacuum vents, hose troughs, sealed manhole, calibrated gage, bulk fuel hoses, portable grounding rod, static reel, and spare tire. A ladder is provided at the front of the M967, M969, and M970, and at the rear of the M967A1, M969A1, and M970A1 semitrailers for access to the top manhole. A vapor recovery system, required in certain ecological areas, can be installed on all models (para 1-9).

*e. Components.* The maintenance paragraphs of this manual contain a detailed description of the components. Differences between models, if pertinent, are included.

#### 1-8. Differences Between Models (Figs. 1-1 through 1-11)

*a. M967 and M967A1.* These models are 5000 gallon bulk haul, self-load/unload semitrailers equipped primarily for bulk delivery of fuel. These models do not have the dispensing capability of the M969, M969A1, M970, and M970A1 semitrailers. The M967 and M967A1 have a 4-cylinder diesel engine and a 4-inch centrifugal pump. The self priming, low-head pump provides a self-load rate of up to 300 gpm and a bulk delivery rate of up to 600 gpm.

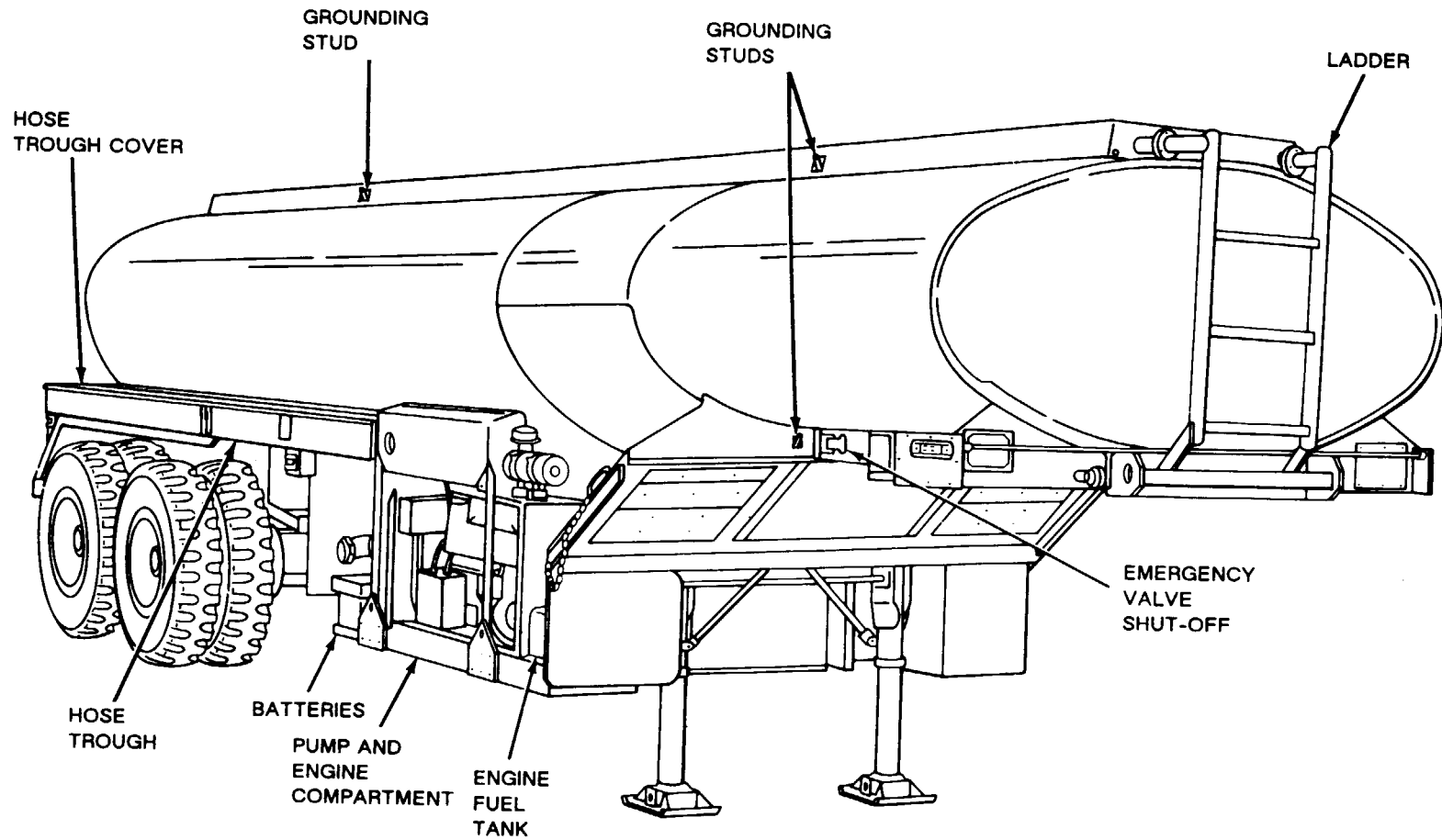

Figure 1-1. Model M967, Tank Semitrailer, Right Front View.

TA502242

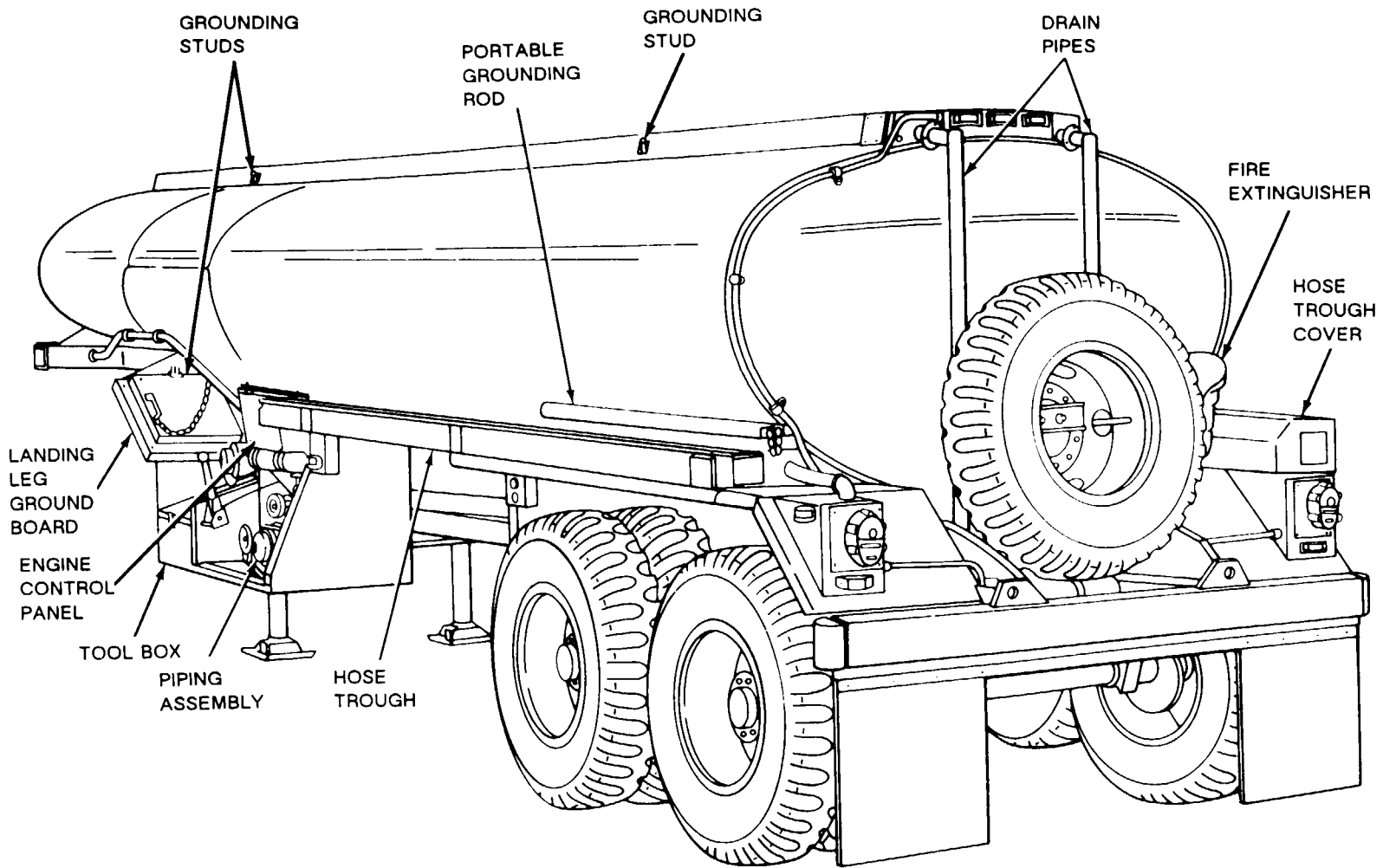

Figure 1-2. Model M967, Tank Semitrailer, Left Rear View.

TA502243

TM 9-2330-356-14

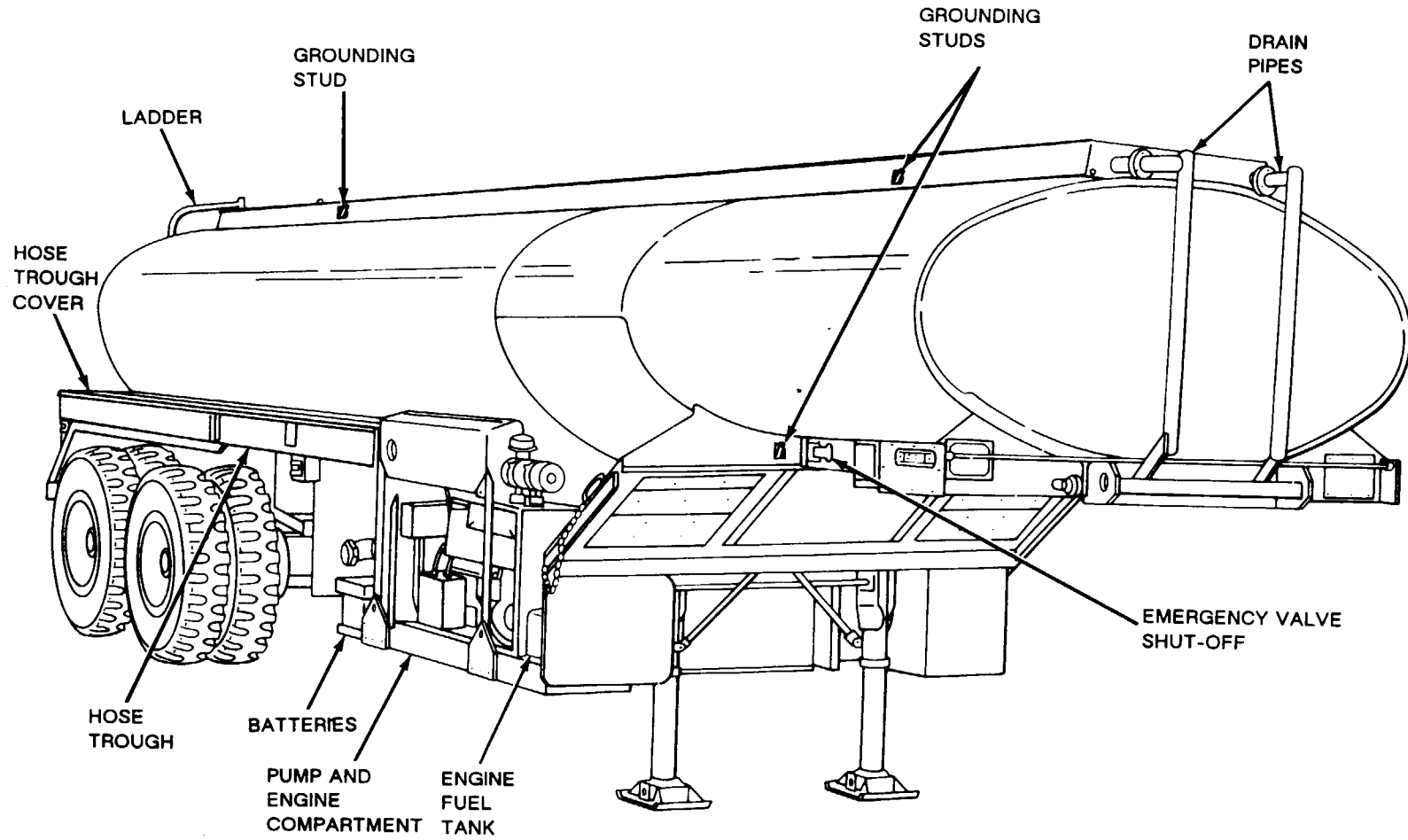

Figure 1-3. Model M967A1, Tank Semitrailer, Right Front View.

TA502244

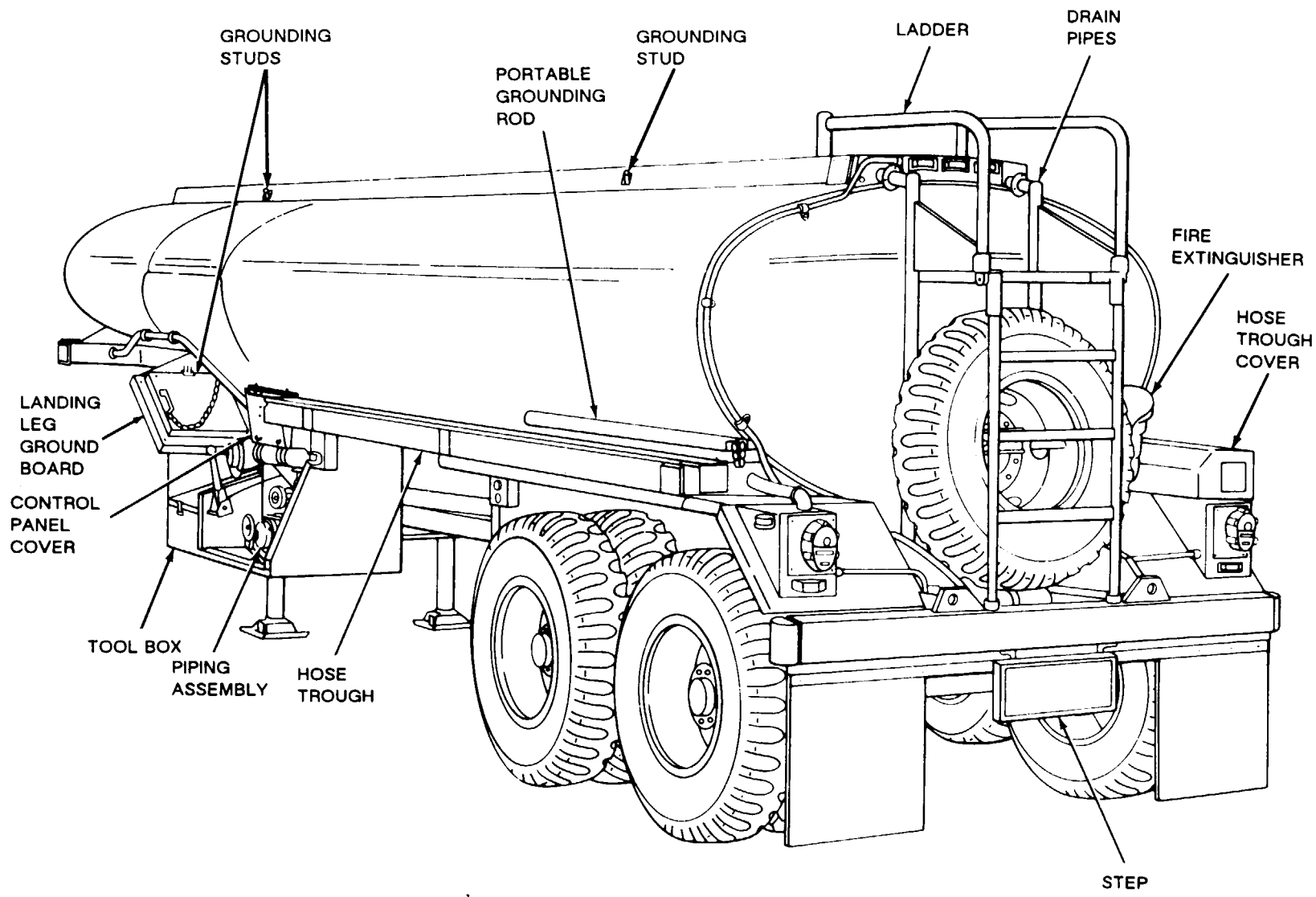

Figure 1-4. Model M967A1, Tank Semitrailer, Left Rear View.

TA502245

TM 9-2330-356-14

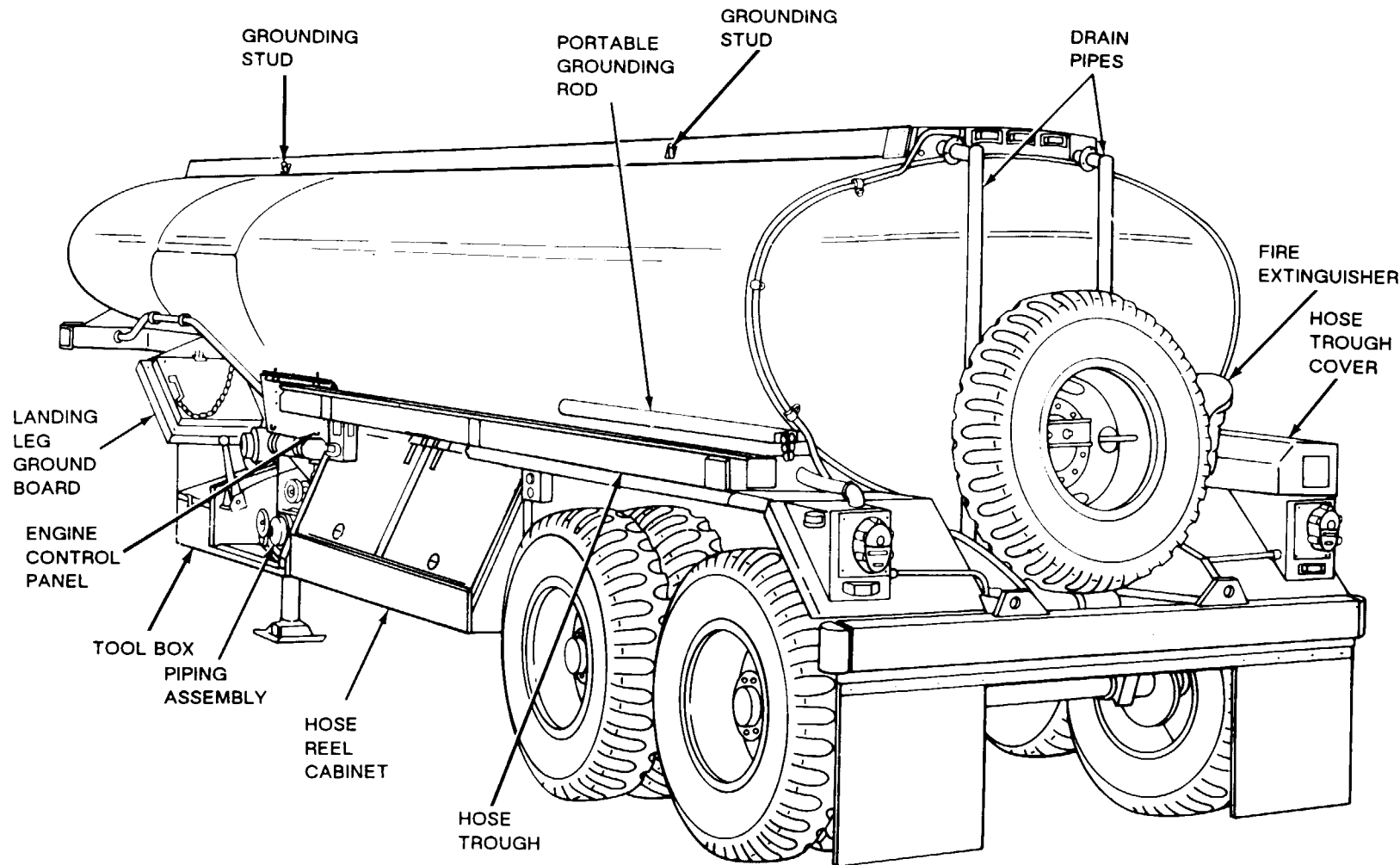

Figure 1-5. Model M969, Tank Semitrailer, Left Rear View.

TA502246

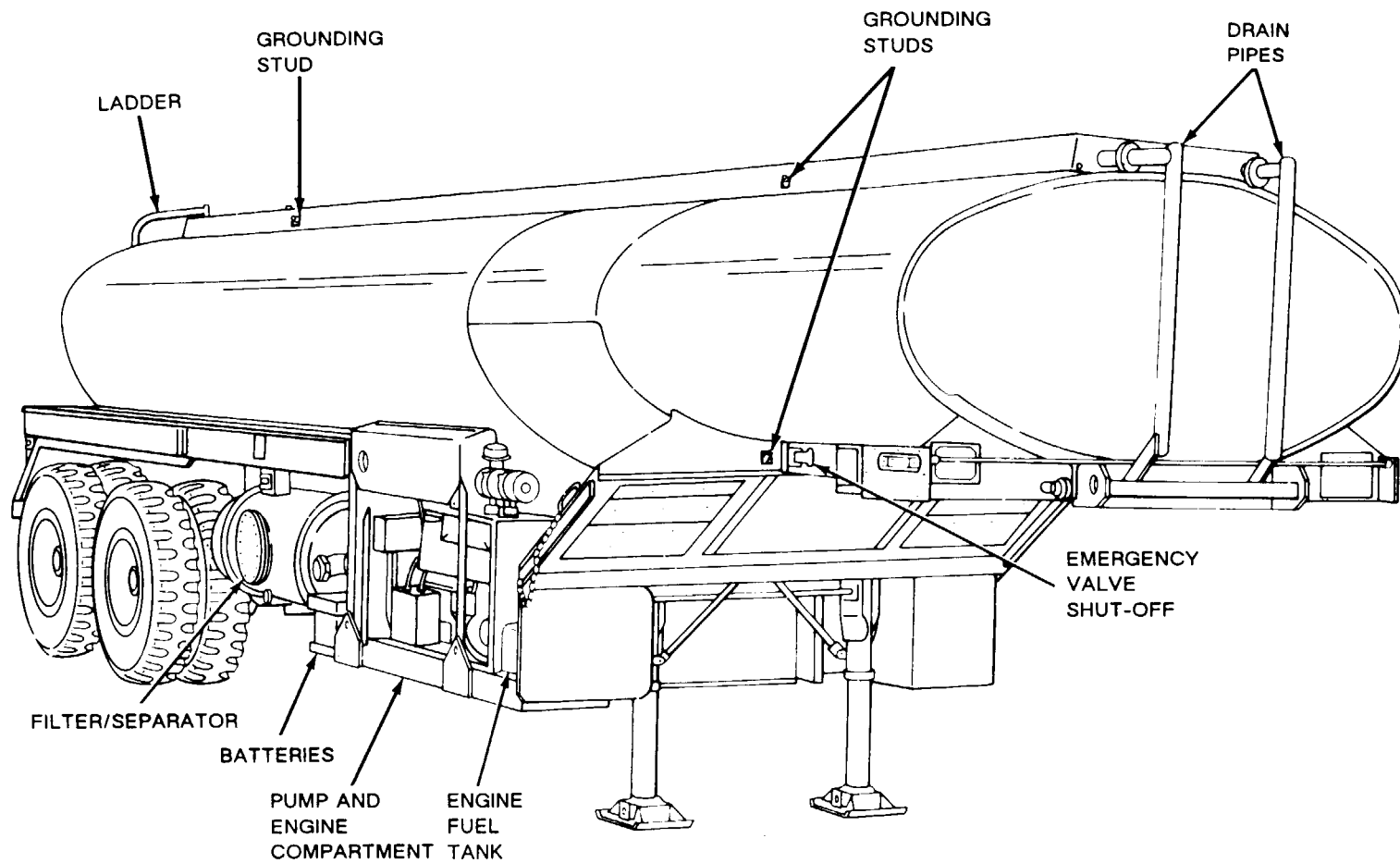

Figure 1-6. Model M969A1, Tank Semitrailer, Right Front View.

TA502247

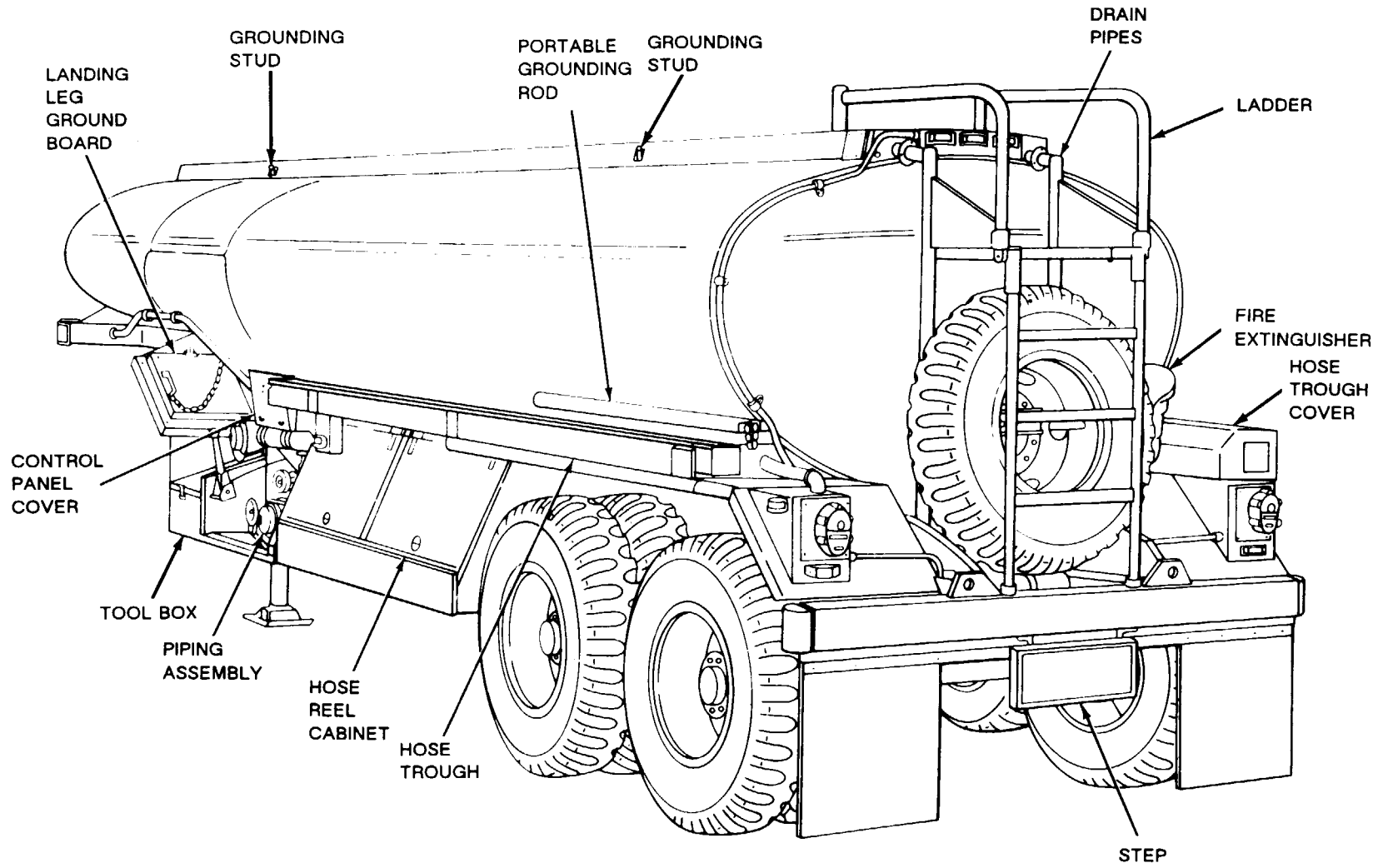

Figure 1-7. Model M969A1, Tank Semitrailer, Left Rear View.

TA502248



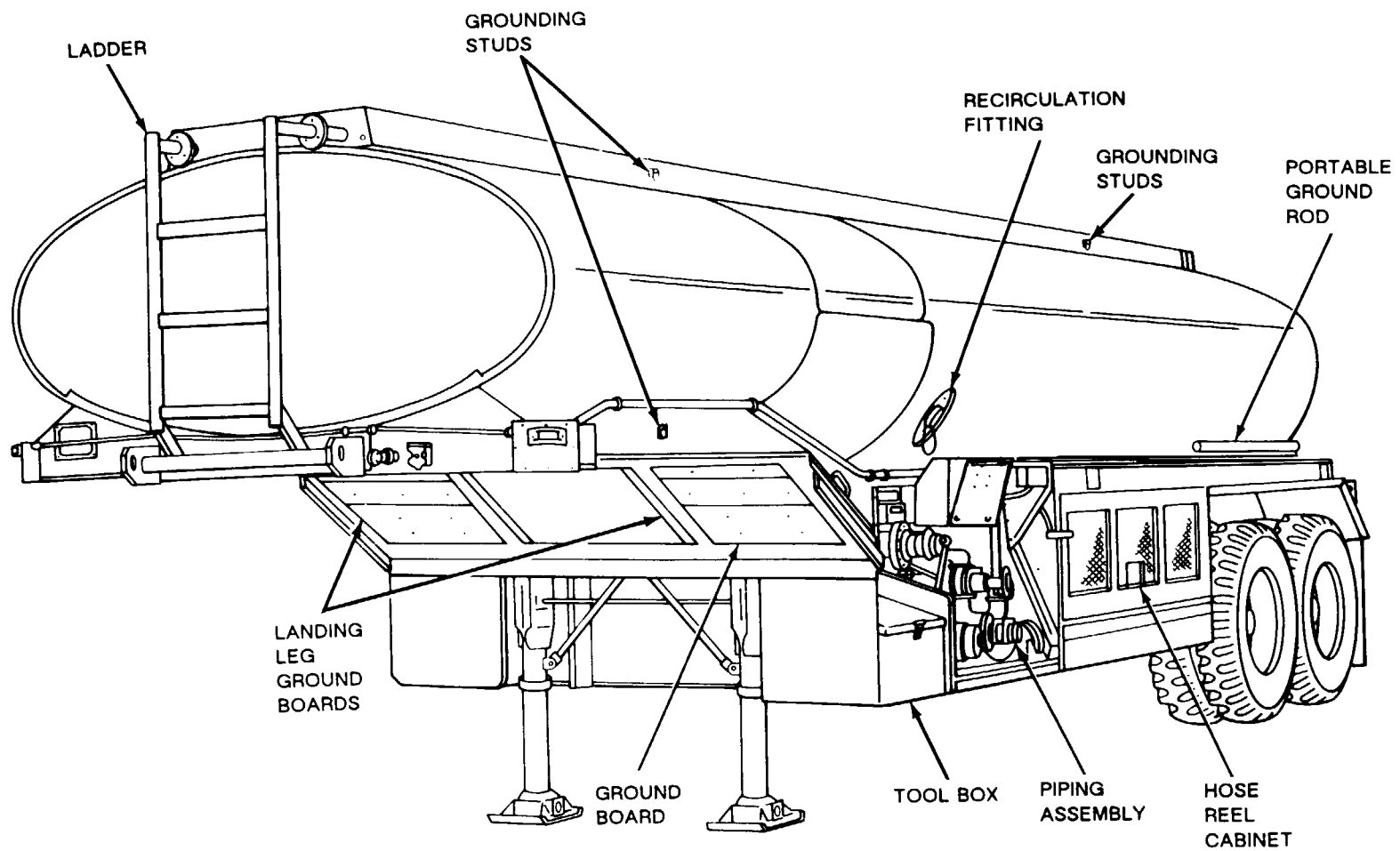

Figure 1-8. Model M970, Tank Semitrailer, Left Front View.

TA502249

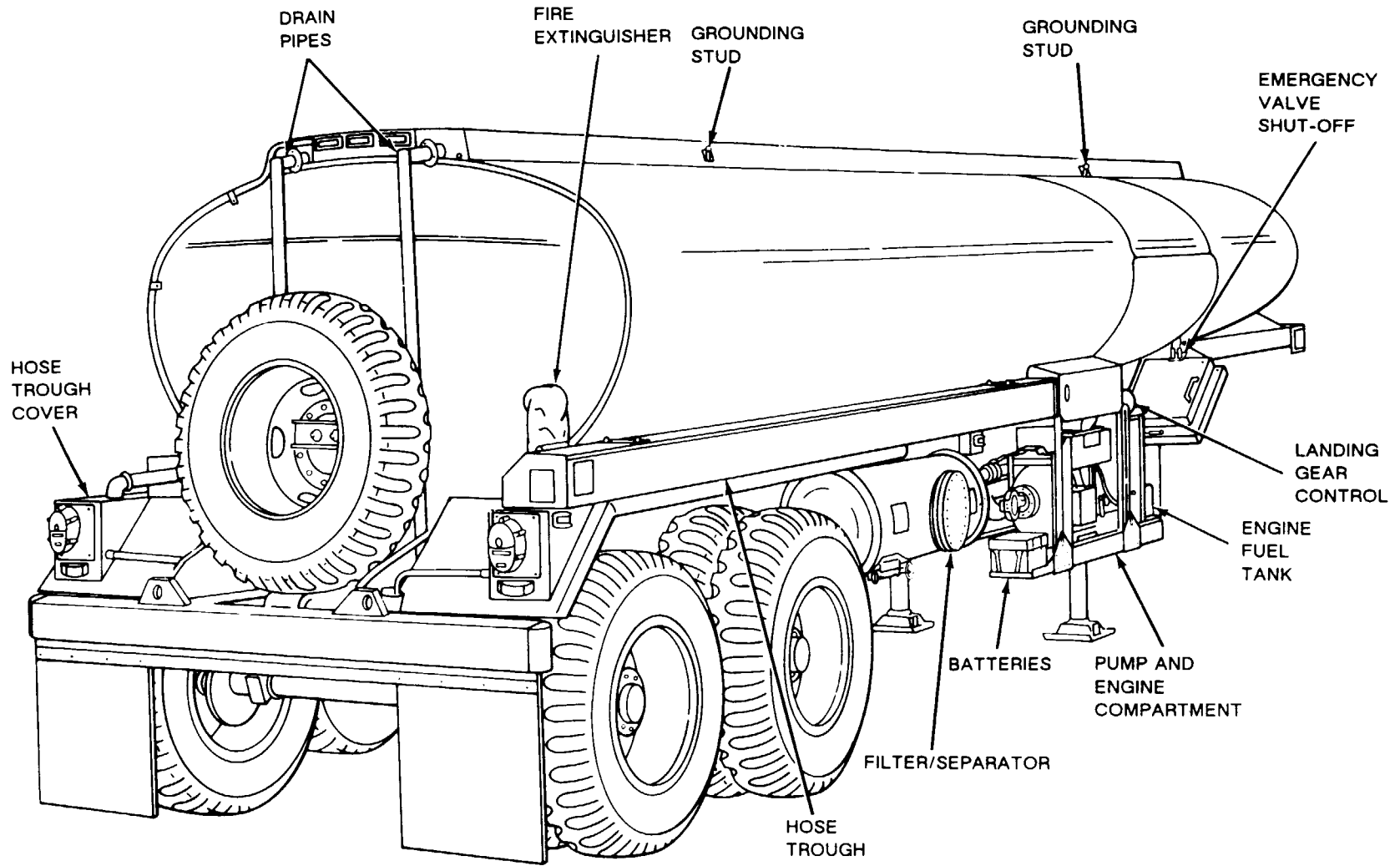

Figure 1-9. Model M970, Tank Semitrailer, Right Rear View.

TA502250

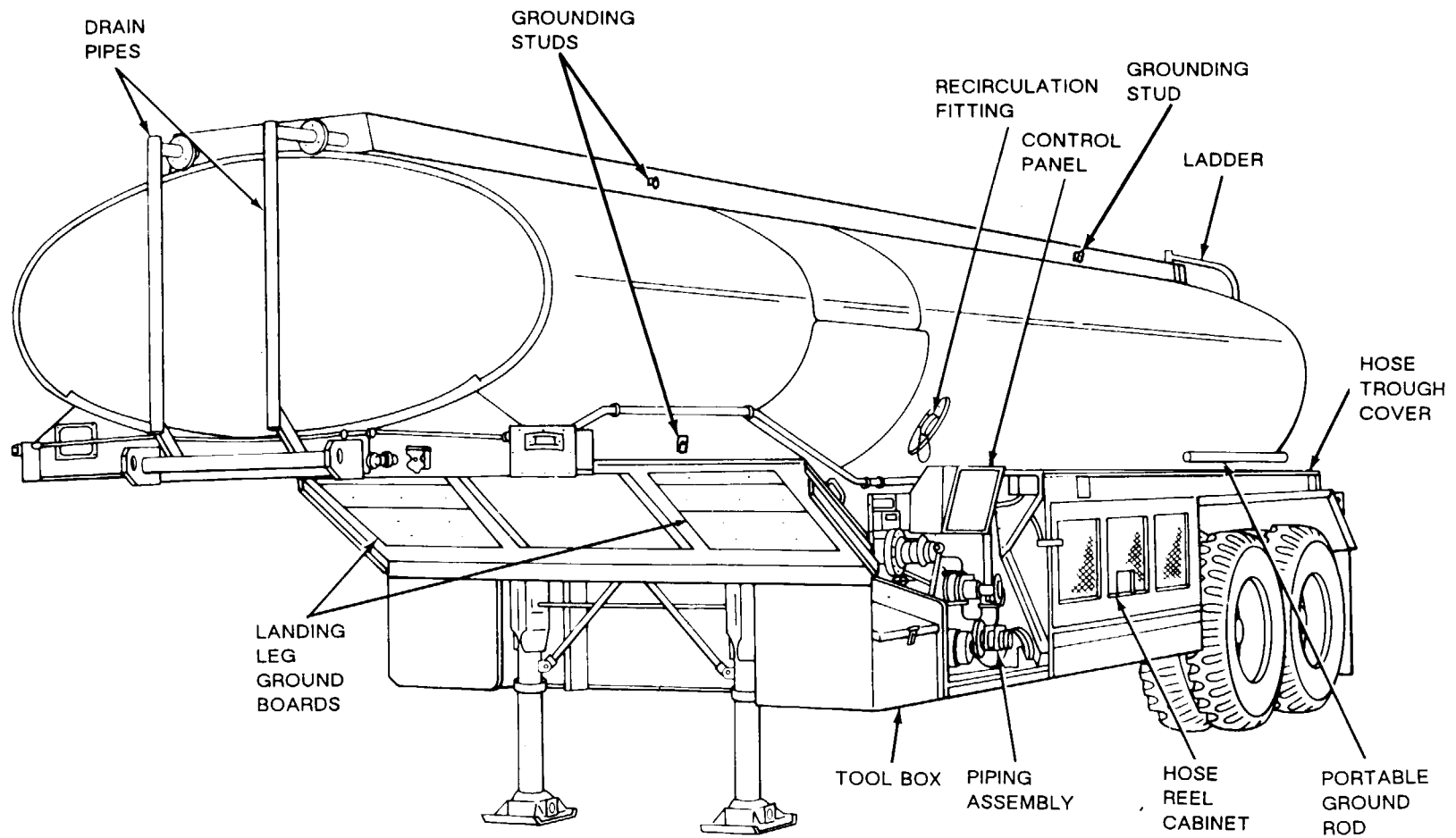

Figure 1-10. Model M970A1, Tank Semitrailer, Left Front View.

TA502251

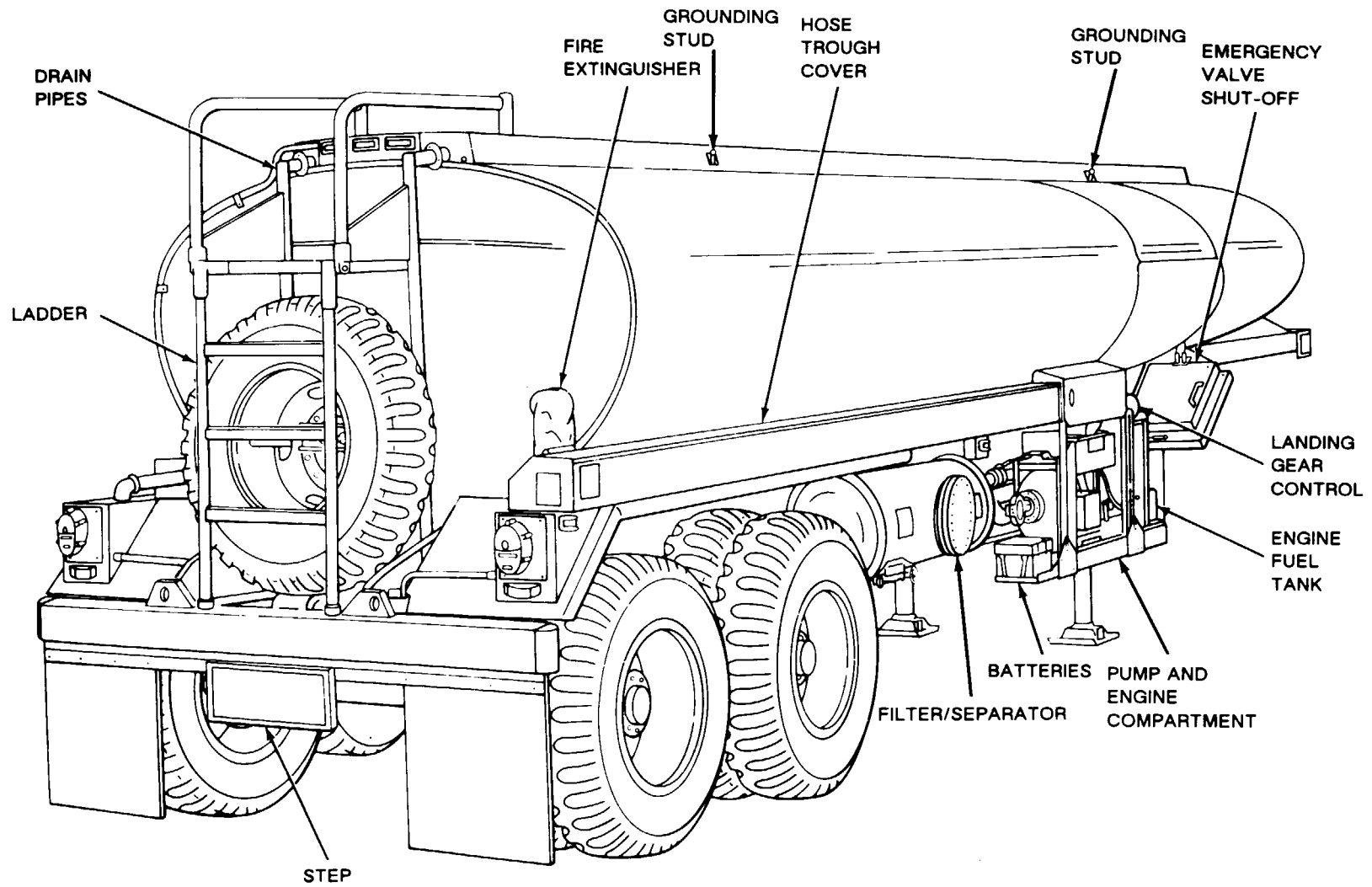

Figure 1-11. Model M970A1, Tank Semitrailer, Right Rear View.

TA502252

b. M969 and M969A1. These models are 5000 gallon fuel dispensing semitrailers used primarily for automotive refueling. These models can also be used for overwing aircraft refueling. The M969 and M969A1 have the same bulk delivery and self-load capabilities as the M967 and M967A1. Additional equipment includes a filter/separator and dual dispensing system. Each dispensing system includes a meter, hose reel with electric rewind 50-feet of 1 1/2-inch dispensing hose, and a dispensing nozzle. Flow rate for metered delivery of fuel (gasoline or diesel) is up to 60 gpm-through one nozzle only, or through both nozzles at the same time.

c. M970 and M970A1. These models are 5000 gallon fuel dispensing semitrailer designed for under/overwing refueling of aircraft. They use the same engine as the M967, M967A1, M969, and M969A1, but have a 3-inch high pressure centrifugal pump. Additional equipment includes a filter/separator, recirculation system, and two refueling systems-one each for undewing and overwing servicing.

(1) *Recirculation System.* This system provides fuel sampling and complete recirculation of fuel through the filtering and dispensing system to remove condensation and contamination.

(2) *Underwing Refueling System.* This system includes 50-feet of 2 1/2-inch hose, electric-rewind hose reel, single point dispensing nozzle, breakaway fitting on the hose reel, and deadman control.

(3) *Overwing Refueling System.* This assembly is part of the above assembly and includes these additional components: 50-feet of 1 1/2-inch dispensing hose, overwing dispensing nozzle, and hose reel with electric-rewind. A small closed-circuit dispensing nozzle (interchangeable with the overwing nozzle) is also provided for underwing (helicopter) refueling.

d. *Upgrades to M967, M969, M970.* A new fuel dispensing nozzle, hose trough cover, control panel cover, rear ladder, front and rear drain, and tachometer and lead assembly have been introduced for *repairing* or upgrading these three models. A new hose reel cabinet door has been introduced for upgrading model M969.

e. *M967A1, M969A1, M970A1 including M970 SNTC-0843, TC-0844, and TC-103 thru TC-178.* These models are the same as models M967, M969, and M970, except for an elastomeric-type drive coupling between the fuel dispensing pump and the engine assembly. A new axle, bogie, and braking system with a "S"-type cam brake actuating mechanism have been installed on these models.

f. *M970 (Marine Corps).* These models, built under Contract Numbers DAAE07-85-C-J044 and DAAE07-89-C-J020, have incorporated the M970A1 dispensing pump, pump coupling, and control panel cover. These items are called out in the repair parts and special tools list figures 113, 116 and 1.

During vehicle production, the following kits have been installed to the M970 Marine Corps vehicle:

(1) *Defueling Kit (Modification Kit, Engine Accessories).* NSN 2910-01-093-7965, Part Number AE20074-008, GAGE 00624.

(2) *Flow Limiter Assembly.* For 1 1/2-in. hose. Stored in the tool box. NSN 3835-01-101-7432, Part Number GTP 1540, CAGE 32218.

(3) *Vapor Recovery Kit.* NSN 2590-00-138-8434, Part Number 1168 5993, CAGE 19207. Figure 102.

g. *M970 (Marine Corps).* These models (SN TC 0843, TC-0844, and TC-103 thru TC-178) built under contract number DAAE07-C-89-J020 have incorporated the M970A1 dolly. The affected are noted in the repair parts and special tools list.

### 1-9. Vapor Recovery Kit

a. *Description.* The system consists of vaportight tine running from a sealed hood on the emergency valve vent (directly behind manhole cover) to the tear of the tank. The rollover rail on the roadside of the semitrailer is used as part of the line. The adapter on the end of the lines is compatible with the 4-inch quick disconnect vapor recovery connections at a majority of fuel depots.

b. *Use.* The vapor recovery system can be installed on all models and is required in certain ecological areas.

(1) The system allows after a fuel depot to collector recover the vapors and gases that are present during the loading operations.

(2) Vapors and gases can also be cycled back to the semitrailer through the recovery system during unloading operations.

### 1-10. Tabulated Data

Angle of departure .....60°

Bridge Classification, M967, M967A1:

Empty weight with tractor .....	Class. 13
Empty weight without tractor .....	Class. 6
Cross-country loaded with tractor .....	Class. 25
Cross-country loaded without tractor .....	Class. 18
Highway loaded with tractor .....	Class. 29
Highway loaded without tractor .....	Class. 21

Bridge Classification, M969, M969A1:

Empty weight with tractor .....	Class. 14
Empty weight without tractor .....	Class. 6
Cross-country loaded with tractor .....	Class. 25
Cross-country loaded without tractor .....	Class. 18
Highway loaded with tractor .....	Class. 30
Highway loaded without tractor .....	Class. 22

Bridge Classification, M970, M970A1:

Empty weight with tractor	Class. 15
Empty weight without tractor	Class. 7
Cross-country loaded with tractor	Class. 26
Cross-country loaded without tractor	Class. 19
Highway loaded with tractor	Class. 30
Highway loaded without tractor	Class. 22

**NOTE**

**Slope over 10%, slight leakage may occur. If slope over 10% anticipated, reduce payload to 3800 gallons.**

Capacities of Tank (Vehicle Capacity):

Hard surface road and cross-country	5000 gal.
20% maximum side slope without leakage	5000 gal.
10% maximum longitudinal slope without leakage	5000 gal.

Center of Gravity:

Empty (vertical)	54 in.
Empty (horizontal from kingpin)	198 in.
Loaded (vertical)	66.5 in.
Loaded (horizontal from kingpin)	170 in.

Dimensions Overall:

Height	104½ in.
Length	366 in.
Width	96 in.
To outside of tires	97¾ in.

Weights:

M967	Empty: 13,000 lb.	Loaded: 46,950 lb.
M967A1	Empty: 13,745 lb.	
M969	Empty: 15,000 lb.	Loaded: 48,950 lb.
M969A1	Empty: 15,580 lb.	
M970 except M970 SN TC-0843, TC-0844, and TC-103 thru TC-178	Empty: 15,200 lb.	Loaded: 49,150 lb.
M970A1 including M970 SN TC-0843, TC-0844, and TC-103 thru TC-178	Empty: 15,460 lb.	
Ground Clearance:		
M970 SN TC-0843, TC-0844, TC-103 thru TC-178 only		16 in.

Kingpin Location:

From nose of vehicle	28 in.
To landing gear	80 in.

Portable Fire Extinguisher.

Type	Purple-K, dry chemical
Size	10 lb.
No. per vehicle	2.

Semitrailer Tank Model Nos.

Bulk haul, self-load/unload	M967, M967A1
Fuel dispensing, automotive	M969, M969A1
Fuel dispensing under/overwing aircraft	M970, M970A1

Tires:

Quantity (including spare)	9
Type	Military nondirectional, cross-country
Size	11.00 x 20-12 ply rating
Tube equipped	Yes

Tire Pressures:

Cross-country and sand	40 psi
Hard surface roads	60 psi

Towing Facility Kingpin

Towing Vehicle (Prime Mover):

5-ton	M52A2, M818, M931, M931A1, M932, and M932A1
10-ton (hard surface highway only)	M915 and M915A1

Track

(Center to center of dual wheels) 72 in.

Transfer Hose:

Type	Flexible
Storage	Trough

Axles (M967, M969, and M970 except M970 SN TC-0843, TC-0844, and TC-103 thru TC-178):

Type	Full floating tandem
Model	SCD-5-32791 (rear) SCD-5-32791-A (front)
Capacity	14,000 lb.

Axles and Suspension

(M967A1, M969A1, and M970A1 including M970 SN TC-0843, TC-0844, and TC-103 thru TC-178):

Axle Model Number	A21T-7CT7R-DW10A
Capacity	25,000 lb.
Model Number	H900-50
Type	Tandem overslung axle

Springs:

Type	Semi-elliptic multi-leaf
Shaft	Semi-elliptic

Brakes (M967, M969, and M970 except M970 SN TC-0843, TC-0844, and TC-103 thru TC-178):

Quantity	4 sets
Type	Fail-safe
Actuation	Full air-wedge type
Operation pressure	75-95 psi

Brakes (M967A1, M969A1, and M970A1 including M970 SN TC-0843, TC-0844, and TC-103 thru TC-178):

Quantity	4 sets
Type	Fail-safe
Actuation	Full air "S"-type cam
Operating pressure	75-95 psi

Deadman Control (Underwing):  
(M970, M970A1 Only)  
Size and Material . . . . . 3-inch aluminum

Drain Valve:  
Working pressure . . . . . 120 psi

Electrical System– Engine:  
Type . . . . . 12V direct current  
Alternator (Model A001-2300JB) . . . . . 65 amps,  
belt drive  
Battery (2) . . . . . 12V, connected in parallel

Electrical System–Vehicle:  
Voltage . . . . . 24V

Lamps:  
Clearance lights . . . . . 3 CP  
Taillights (service) . . . . . 3 CP  
Taillights (blackout) . . . . . 3 CP  
Stoplights (service) . . . . . 32 CP

Engine:  
Type . . . . . (Onan) 4 cyl, 4 cycle, diesel, air-cooled  
Model . . . . . DJC-MS4118W  
Horsepower . . . . . 27.5  
Bore . . . . . 3.25  
Stroke . . . . . 3.625  
Oil Capacity Crankcase:  
Without filter change (quarts) . . . . . 6  
With oil filter change (quarts) . . . . . 6½  
Displacement (cu. in.) . . . . . 120  
Injection (firing) sequence . . . . . 1-2-4-3

Throttle Control:  
Length . . . . . 100 in.  
Model . . . . . Flexible  
Type . . . . . Push-pull w/locking handle

Engine Air Cleaner:  
Capacity (Air-flow) . . . . . 115 cpm @ 12 in. H<sub>2</sub>O

Filter/Separator:  
Construction . . . . . Aluminum  
Rating . . . . . 300 gpm 150 psi  
Differential pressure gage psi indicator, 0-25 psid

Fuel Dispensing Nozzles:  
Trigger Control (used with deadman control on  
M970 and M970A1):  
Nominal size . . . . . 1½ in.  
Function . . . . . Automotive/overwing/purge with  
adapter  
Quantity . . . . .  
Capacity . . . . . 100 gpm

Single Point, Pressure Shut-off with Deadman  
Controls:  
Nominal size . . . . . 2½ in.  
Function . . . . . Underwing/recirculation/purge/  
self-load/defueling

Quantity . . . . .  
Capacity . . . . . 300 gpm

Closed Circuit Pressure Shut-off  
Nominal size . . . . . 1½ in.  
Function . . . . . Helicopter only  
Quantity . . . . . 1  
Capacity . . . . . 100 gpm

Fuel Dispensing Hose (Automotive,  
Overwing, M969, and M969A1):  
Length . . . . . 50 ft.  
Quantity . . . . . 2  
Nominal size . . . . . 1¼ in.

Fuel Dispensing Hose  
(Overwing, M970 and M970A1):  
Length . . . . . 50 ft.  
Quantity . . . . . 1  
Nominal size . . . . . 1½ in.

Fuel Dispensing Hose  
(Underwing, M970 and M970A1):  
Length . . . . . 50 ft.  
Quantity . . . . . 1  
Nominal size . . . . . 2½ in.

Bulk Fuel Servicing Hose:  
(Two w/male and female connectors,  
One w/female connector, both ends)  
Length . . . . . 14 ft.  
Quantity . . . . . 3  
Nominal size . . . . . 4 in.

Hose Reels:  
Type . . . . . Electric-full control and manual crank

Landing Gear:  
Type . . . . . Vertical support w/foot pads  
Operation . . . . . Hand crank, two-speed

Meter (M969 and M969A1):  
Quantity . . . . . 2  
Type . . . . . Full metering  
Maximum capacity . . . . . 100 gpm

Meter (M970 and M970A1):  
Quantity . . . . . 1  
Type . . . . . Full metering  
Maximum capacity . . . . . 300 gpm

Pump (4 in. Model) Bulk Haul,  
Self-load/unload, Overwing Automotive  
(M967, M967A1, M969 and M969A1):  
Type . . . . . Low pressure, centrifugal  
Drive . . . . . Shaft from engine

Pump (3 in. Model) (Underwing/overwing)  
(M970 and M970A1):  
Type . . . . . High pressure, centrifugal  
Drive . . . . . Shaft from engine

Emergency Valve Control:  
Type . . . . . Full release  
Control . . . . . Flexible cable

**1-11. Identification and Instruction Plates**  
**(Figs. 1-12 through 1-16)**

a. *Vehicle Identification Plate.* Mounted on frame on left side of vehicle. Identifies vehicle model, weight, dimensions, vehicle identification number, and contract number.

b. *D.O.T Data Plate.* Mounted on front frame on the right side between the service brake coupling and the front marker light. Identifies manufacturer's serial number, D.O.T (Department of Transportation) specifications, shell material, head material, welding specification, and lining.

c. *Bottom Loading Instruction Plate.* Located on left side of vehicle above the piping control cabinet. Indicates instructions for bottom loading.

d. *Flow Rate/RPM Plate.* Mounted on left side of frame next to the control panel. Gives maximum gallons per minute at set engine rpm.

e. *Hose Rewind Plate (M969 and M969A1).* Mounted in hose reel cabinet on each meter mounting plate. Indicates caution when rewinding hoses.

f. *Hose Rewind Plate (M970 and M970A1).* Mounted in hose reel cabinet on each meter mounting plate. Indicates caution when rewinding hoses.

g. *Operating Instructions Plate.* Mounted on tool box cover. Indicates valve positions for various operating functions.

h. *Engine Operating Instruction Plate.* Mounted on left side of frame above the control panel. Gives specific engine operating instructions.

i. *Precheck Operation Plate (M970 and M970A1).* Mounted on frame next to control panel. Indicates open and closed position of precheck valve.

j. *Throttle Plate.* Mounted on frame next to control panel. Indicates direction to increase and decrease throttle.

k. *Deadman Deactivation Plate (M970 and M970A1).* Mounted in hose reel cabinet on meter mounting plate. Gives instructions to deactivate deadman control.

l. *Vapor Recovery Plate.* Mounted on frame on left side of vehicle in front of ground board. Indicates instructions for vapor recovery operation.



<p>SEMI TRAILER TANK 5000 GAL M967                  FEDERAL STOCK NO 2330 01 050-5632                  MANUFACTURED BY THE HEIL COMPANY                  MILWAUKEE WISCONSIN 53201 U.S.A.                  U.S. DEPARTMENT OF TRANSPORTATION                  NATIONAL FIRE PROTECTION ASSOCIATION</p>	<p>WEIGHT AND DIMENSION DATA                  FOR 100%                  FULLY LOADED</p>
<p>MANUFACTURED BY THE HEIL COMPANY                  MILWAUKEE WISCONSIN 53201 U.S.A.</p>	<p>WEIGHT EMPTY PRESSURE IN THE HIGHWAY                  FRONT 24,000 LBS. REAR 24,000 LBS.                  2 AXLES 48,000 LBS. 2 AXLES 48,000 LBS.                  TOTAL 96,000 LBS. 2 AXLES 48,000 LBS.</p>
<p>SHIPPING CRADLE REQUIRED</p>	

**THE HEIL COMPANY  
 MILWAUKEE, WISCONSIN**  
 53201

MFG'S N [REDACTED] DATE [REDACTED]  
 DOT MC 306 SS CERT [REDACTED]  
 PRES DESIGN 0 P.S.I.G. 180 F  
 TEST 3 P.S.I.G. DATE [REDACTED]  
 MATL SHELL T304 S.S. HEAD T304 S.S.  
 WELD 308 LINING NONE  
 ONE COMPT 5000 U.S. GAL.  
 MAX. LOAD 37 500 LBS. 7.5 LBS GAL.  
 LIMIT LD. 1.5 P.S.I.G. UNLD 0.5 P.S.I.G.

**VAPOR RECOVERY KIT, FUEL SERVICING**

MANUFACTURED BY THE HEIL COMPANY  
 MILWAUKEE WISCONSIN 53201 U.S.A.  
 KIT IDENTIFICATION NO. **11685993**  
 CONTRACT NO. [REDACTED]

PUBLICATIONS  
 TECHNICAL MANUAL TM 9-2330-356-14

DELIVERY DATE [REDACTED] INSPECTED [REDACTED]

**ENGINE OPERATING INSTRUCTIONS**

1. CHECK ENGINE FUEL AND OIL LEVELS. USE NO. 2 DIESEL FUEL ABOVE 32 F. USE NO. 1 DIESEL FUEL BELOW 32 F.
2. TO START THE ENGINE HOLD PREHEAT SWITCH ON FOR 1 MINUTE WHILE HOLDING PREHEAT SWITCH PUSH FUEL SOLENOID SWITCH TO "RUN" AND PRESS START SWITCH RELEASE WHEN ENGINE STARTS.
3. IF ENGINE FAILS TO START AFTER CRANKING 1 MINUTE PREHEAT 1 MINUTE MORE AND PRESS START SWITCH.
4. TO STOP THE THROTTLE ENGINE TO FAST IDLE AND PUSH FUEL SOLENOID SWITCH TO "STOP".
5. ENGINE IS RESTARTED AFTER SHORT PERIOD OF TIME PREHEAT IS USUALLY NOT REQUIRED.

FOR OTHER INSTRUCTIONS CONSULT ENGINE SERIAL NUMBER PLATE AND OPERATORS MANUAL

[REDACTED]

**OPERATING INSTRUCTIONS M967**

BEFORE STARTING ENGINE AND ENGINE WITH ALL VALVES CLOSED

OPERATION	VALVE POSITIONS
WATER OPEN	A, B, C, D, E, F, G, H, I, J, K, L, M, N, O, P, Q, R, S, T, U, V, W, X, Y, Z
PREHEAT ON	A, B, C, D, E, F, G, H, I, J, K, L, M, N, O, P, Q, R, S, T, U, V, W, X, Y, Z
WATER CLOSED	A, B, C, D, E, F, G, H, I, J, K, L, M, N, O, P, Q, R, S, T, U, V, W, X, Y, Z
PREHEAT OFF	A, B, C, D, E, F, G, H, I, J, K, L, M, N, O, P, Q, R, S, T, U, V, W, X, Y, Z
ENGINE START	A, B, C, D, E, F, G, H, I, J, K, L, M, N, O, P, Q, R, S, T, U, V, W, X, Y, Z
ENGINE STOP	A, B, C, D, E, F, G, H, I, J, K, L, M, N, O, P, Q, R, S, T, U, V, W, X, Y, Z
ENGINE RESTART	A, B, C, D, E, F, G, H, I, J, K, L, M, N, O, P, Q, R, S, T, U, V, W, X, Y, Z
ENGINE RUN	A, B, C, D, E, F, G, H, I, J, K, L, M, N, O, P, Q, R, S, T, U, V, W, X, Y, Z
ENGINE STOP	A, B, C, D, E, F, G, H, I, J, K, L, M, N, O, P, Q, R, S, T, U, V, W, X, Y, Z
ENGINE RESTART	A, B, C, D, E, F, G, H, I, J, K, L, M, N, O, P, Q, R, S, T, U, V, W, X, Y, Z
ENGINE RUN	A, B, C, D, E, F, G, H, I, J, K, L, M, N, O, P, Q, R, S, T, U, V, W, X, Y, Z

**A** IN AN EMERGENCY CLOSE VALVE A OR PULL EMER VALVE SHUT OFF ON OPPOSITE SIDE

**B** USE HIGH ENGINE SPEED ONLY TO ATTAIN MAXIMUM FLOW START ENGINE BEFORE OPENING VALVES

**THROTTLE  
 LOCK**

<p><b>VALVE E                  FUNCTION SELECTOR</b></p>	<p><b>VALVE D                  LOADING PRE CHECK</b></p>
<p><b>CAUTION</b>                  PRE CHECK AT START OF EACH BOTTOM LOADING OR SELF LOADING OPERATION</p>	

Figure 1-12. Identification and Instruction Plates (M967 and M967A1).

TA099679

**THE HEIL COMPANY  
MILWAUKEE, WISCONSIN**

MFG'S N [ ] DATE [ ]  
 DOT MC 306 SS CERT [ ]  
 PRES DESIGN 0 PSIG 180 F  
 TEST 3 PSIG DATE [ ]  
 MATL SHELL T304 SS HEAD T304 SS  
 WELD 308 LINING NONE  
 ONE COMPT 5000 U S GAL  
 MAX LOAD 37,500 LBS. 7.5 LBS GAL.  
 LIMIT LD 15 PSIG UNLD 0.5 PSIG

**VAPOR RECOVERY KIT, FUEL SERVICING**

MANUFACTURED BY THE HEIL COMPANY  
 MILWAUKEE, WISCONSIN 53201 U.S.A.

KIT IDENTIFICATION NO. **11685993**  
 CONTRACT NO. [ ]

PUBLICATIONS  
 TECHNICAL MANUAL TM 9-2330-356-14

DELIVERY DATE [ ] INSPECTED [ ]

**CAUTION**

A DO NOT REWIND HOSE REELS SIMULTANEOUSLY  
 B REWIND HOSES WHILE ENGINE IS RUNNING TO AVOID DISCHARGING BATTERY

**FUEL DISPENSING AUTOMOTIVE M969**

	SELF LOADING		KIT DISPENSING				BULK DELIVERY			
			THRU FILTER		BYPASS FILTER		THRU FILTER		BYPASS FILTER	
ENG RPM	2200	2400	1200	2400	1200	2400	2200	2400	2200	2400
PUMP GPM	290	320	44	88	44	88	175	190	480	530

DECREASE ENGINE RPM TO OBTAIN LOWER PUMP GPM IF REQ'D

**ENGINE OPERATING INSTRUCTIONS**

- CHECK ENGINE FUEL AND OIL LEVELS. USE NO. 2 DIESEL FUEL ABOVE 32 F. USE NO. 1 DIESEL FUEL BELOW 32 F.
- TO START COLD ENGINE, HOLD PREHEAT SWITCH ON FOR 1 MINUTE WHILE HOLDING PREHEAT SWITCH. PUSH FUEL SOLENOID SWITCH TO 'RUN' AND PRESS START SWITCH. RELEASE WHEN ENGINE STARTS.
- IF ENGINE FAILS TO START AFTER CRANKING 1 MINUTE, PREHEAT 1 MINUTE MORE AND PRESS START SWITCH.
- TO SHUT OFF, THROTTLE ENGINE TO FAST IDLE AND PUSH FUEL SOLENOID SWITCH TO 'STOP'.
- IF ENGINE IS RESTARTED AFTER SHORT PERIOD OF TIME, PREHEAT IS USUALLY NOT REQUIRED.

FOR OTHER INSTRUCTIONS CONSULT ENGINE SERIAL NUMBER PLATE AND OPERATORS MANUAL

11685840

**THROTTLE  
LOCK**

**VALVE E FUNCTION SELECTOR**  
 (CLOSE) (OPEN)

**VALVE D LOADING PRE CHECK**  
 (CLOSE) (OPEN)

**CAUTION**  
 PRE CHECK AT START OF EACH BOTTOM LOADING OR SELF LOADING OPERATION

Figure 1-13. Identification and Instruction Plates (M969 and M969A1).

TA099680

### OPERATING INSTRUCTIONS (M969)

EACH OPERATION BEGINS AND ENDS WITH ALL VALVES CLOSED

OPERATION	VALVE POSITIONS																	
	A	B	C	D	E	F	G	H	J	K	M	P	R					
1 WATER DRAIN	0																	
2 GRAVITY UNLOAD	0	0	0	0				0	0									
3 BOTTOM LOAD	0				L													
4 BULK DELIVERY	0	0	0	0		U	0		D									
5 BELF LOAD	0	0	0	0		L												
6 FILTERED BULK DLVY	0	0	0	0		U			D		D							
7 KIT DISP FILTERED	0					U			D					0	0	0	0	0
8 KIT DISP NON FILTR	0					U			D					0	0	0	0	0
9 PRE-CHECK					0													

O= OPEN      L= LOAD      U= UNLOAD

A IN AN EMERGENCY CLOSE VALVE 'A' OR PULL EMER VALVE SHUT OFF ON OPPOSITE SIDE

B PERIODICALLY CHECK FILTER SEPARATOR PRESSURE DIFFERENTIAL

C DO NOT EXCEED 100 GPM THRU FILTER WHEN PUMPING DIESEL FUEL (MOTOR GASOLINE 100 G.P.M.)

D USE HIGH ENGINE SPEED ONLY TO ATTAIN MAXIMUM FLOW. START ENGINE BEFORE OPENING VALVES.

#### SEMI-TRAILER TANK, 5000 GAL., M969

#### FEDERAL STOCK NO. 2330-01-050-5634

MANUFACTURED BY THE HEIL COMPANY  
MILWAUKEE WISCONSIN 53201 U.S.A.

VEHICLE IDENTIFICATION NO.

CONTRACT NO.

#### WEIGHT AND DIMENSION DATA

#### PUBLICATIONS

TECHNICAL MANUALS      TM 9 2330 356 12&P  
TM 9 2330 356 34&P

DELIVERY DATE       INSPECTED

WEIGHT	EMPTY	CROSSCOUNTRY & HIGHWAY
PAYLOAD		33,950 LBS
ON WHEELS	10,200 LBS	29,300 LBS
ON KINGPIN	4,800 LBS	19,650 LBS
TOTAL	15,000 LBS	48,950 LBS

SHIPPING CUBAGE - 2200 CU. FT.

Figure 1-14. Identification and Instruction Plates (M969 and M969A1) (Con't).

TA099681

**ENGINE OPERATING INSTRUCTIONS**

- 1 CHECK ENGINE FUEL AND OIL LEVELS. USE NO 2 DIESEL FUEL ABOVE 32 F. USE NO 1 DIESEL FUEL BELOW 32 F.
- 2 TO START COLD ENGINE HOLD PREHEAT SWITCH ON FOR 1 MINUTE WHILE HOLDING PREHEAT SWITCH PUSH FUEL SOLENOID SWITCH TO "RUN" AND PRESS START SWITCH RELEASE WHEN ENGINE STARTS
- 3 IF ENGINE FAILS TO START AFTER CRANKING 1 MINUTE. PREHEAT 1 MINUTE MORE. AND PRESS START SWITCH
- 4 TO SHUT OFF THROTTLE ENGINE TO FAST IDLE AND PUSH FUEL SOLENOID SWITCH TO "STOP"
- 5 IF ENGINE IS RESTARTED AFTER SHORT PERIOD OF TIME. PREHEAT IS USUALLY NOT REQUIRED

FOR OTHER INSTRUCTIONS CONSULT ENGINE SERIAL NUMBER  
PLATE AND OPERATORS MANUAL

11685840

**VALVE D**  
**LOADING PRE CHECK**

OPEN  CLOSED

**CAUTION**  
PRE-CHECK AT START OF EACH BOTTOM  
LOADING OR SELF LOADING OPERATION

FUEL DISPENSING AIRCRAFT UNDERWING/OVERWING M970

	SELF LOAD		OVERWING		UNDERWING		DEFUEL	
	2200	2400	2200	2400	2200	2400	2200	2400
ENG R P M	2200	2400	2200	2400	2200	2400	2200	2400
PUMP G P M	220	240	90	100	220	240	50	60

DECREASE ENG R P M TO OBTAIN LOWER PUMP G P M

**VAPOR RECOVERY KIT, FUEL SERVICING**

MANUFACTURED BY THE HEIL COMPANY  
MILWAUKEE WISCONSIN 53201 U.S.A.

KIT IDENTIFICATION NO.

CONTRACT NO.

PUBLICATIONS  
TECHNICAL MANUAL TM 9 2330 356 14

DELIVERY DATE  INSPECTED

**CAUTION**

- A DO NOT REWIND HOSE REELS SIMULTANEOUSLY
- B BEFORE SERVICING AIRCRAFT. CONNECT "V" GROUNDING CABLE TO EACH AIRCRAFT AND GROUND
- C REWIND HOSES WHILE ENGINE IS RUNNING TO AVOID DISCHARGING BATTERY
- D BEFORE CHANGING NOZZLES ON FRONT REEL. CHECK THAT SYSTEM IS OFF AND PRESSURE IS RELIEVED

**THROTTLE**

LOCK



**TO DEACTIVATE DEADMAN SYSTEM  
FOR OVERWING REFUELING**

DEPRESS DEADMAN VALVE S AND  
RELEASE THEN DEPRESS VALVE  
PLUNGER AND HOLD FOR 5 TO  
10 SECONDS

**THE HEIL COMPANY**  
**MILWAUKEE, WISCONSIN**  
53201

MFG'S N  DATE

D.O.T. MC 306 S.S. CERT.

PRES DESIGN 0 P.S.I.G. 180° F

TEST 3 P.S.I.G. DATE

MATL SHELL-T304 S.S. HEAD-T304 S.S.

WELD-308 LINING-NONE

ONE COMPT 5000 U.S. GAL.

MAX. LOAD 37,500 LBS. 7.5 LBS/GAL.

LIMIT LD. 1.5 P.S.I.G. UNLD 0.5 P.S.I.G.

TA099682

Figure 1-15. Identification and Instruction Plates (M970 and M970A1).

### OPERATING INSTRUCTIONS

BEGIN AND END EACH OPERATION WITH ALL VALVES CLOSED

OPERATION (O = OPEN)	VALVE POSITIONS															
	A	B	D	E	F	G	H	J	K	M	N	P	R	S		
1 WATER DRAIN	O							O	O			O				
2 GRAVITY UNLOAD	O	O						O	O							
3 FILTERED SELF FLOW	O	O						O					O	O		
4 FILTERED BULK DLVY	O	O						O	O							
5 SINGLE POINT DSP	O							O					O	O		
6 OVERWING DSP	O							O					O	O		
7 2-1/2" HOSE DEFUEL	O							O					O	O		
8 1-1/2" HOSE DEFUEL	O							O					O	O		
9 2-1/2" HOSE EVAC	O			O						O				O		
10 1-1/2" HOSE EVAC	O			O						O				O		
11 2-1/2" HOSE RECIRC	O							O					O	O		
12 1-1/2" HOSE RECIRC	O							O					O	O		
13 NON FILTR BULK DLVY	O	O						O								
14 NON FILTR BOT LOAD	O	O						O								
15 PRECHECK			O													

A) IN AN EMERGENCY, CLOSE VALVE "A" OR PULL EMER VALVE SHUT OFF ON OPPOSITE SIDE  
 B) START ENGINE BEFORE OPENING VALVES  
 C) CHECK ALL GAUGES AFTER STARTING ENGINE  
 D) USE HIGH ENGINE SPEED ONLY TO ATTAIN MAXIMUM FLOW

### PIPING SCHEMATIC - (M970)

The diagram shows a complex piping system. Key components include:
 

- ENGINE**: Connected to a **PUMP** and a **SCREEN**.
- EMER VALVE SHUT OFF**: Located near the engine.
- EMER VALVE**: Located on the main line.
- FILTER SEPARATOR**: Connected to the main line.
- METER**: Located on the line between the filter separator and the rear reel.
- REAR REEL** and **FRT REEL**: The end points of the piping system.
- LOADING CONNECTION**: A central junction point.
- OUTLET SUMP** and **AUTO WATER DRAIN**: Connected to the filter separator.
- OPERATOR**: Located at the bottom left of the diagram.

### SEMI-TRAILER TANK, 5000 GAL., M970

FEDERAL STOCK NO. 2330-01-050-5635

MANUFACTURED BY THE HEIL COMPANY  
 MILWAUKEE WISCONSIN 53201 U.S.A.

VEHICLE IDENTIFICATION NO

CONTRACT NO

#### WEIGHT AND DIMENSION DATA

Dimensions: 368 (total length), 301 (main length), 55 (rear overhang), 187 (CG LOADED), 50 (CG EMPTY), 211 (CG EMPTY).

Other dimensions: 56 (height), 17 (width), 80 (wheelbase), 178 (wheelbase), 52 (width), 98 (width), 96 (height), 104 (height), 46 (width).

#### PUBLICATIONS

TECHNICAL MANUALS TM 9 2330 356 12&P  
 TM 9 2330 356 34&P

DELIVERY DATE  INSPECTED

	EMPTY	CROSSCOUNTRY & HIGHWAY
PAYLOAD		33,950 LBS
ON WHEELS	10,400 LBS	29,400 LBS
ON KINGPIN	4,800 LBS	19,750 LBS
TOTAL	15,200 LBS	49,150 LBS

SHIPPING CUBAGE - 2.000 CU. FT

TA099683

Figure 1-16. Identification and Instruction Plates (M970 and M970A1) (Con't).



## CHAPTER 2 OPERATING INSTRUCTIONS

---

### Section I. OPERATING PROCEDURES

#### WARNING

If incorrectly used, this equipment can cause severe injury or death. Those who use and maintain the equipment should be trained in its proper use, should be warned of its dangers, and should read the entire manual before attempting to set up, operate, adjust, or service the equipment.

#### 2-1. General

This section provides operator/crew instructions for operation and proper use of the M967, M967A1, M969, M969A1, M970, and M970A1 semitrailers. Operations common to all six models are described first, followed by those operations which pertain to a particular model.

#### 2-2. Before-Operation Service

#### WARNING

- **Frequent inspection of equipment, safety devices, and working areas must be performed to ensure personal and operational safety and to correct potential or actual hazards.**
- **The semitrailer must not be operated if any of the following conditions exist:**
  - a. Fuel leaks.**
  - b. Damage to lighting fixtures, wiring or electrical conduits, or lights inoperative.**
  - c. Damage to towing vehicle or semitrailer.**
  - d. Primary or parking brake systems inoperative.**
  - e. Vents plugged, inoperative, or removed. Pressure, vacuum, and fusible vents are installed to meet code requirements and to protect the semitrailer from**

**damage. A plugged or inoperative vent can cause extensive shell damage if design pressure or vacuum is exceeded. The fusible vents are designed to operate at high temperatures. If these vents are coated with paint, dirt, or other foreign material, the temperature when relief occurs may be greatly increased.**

*a.* This is a brief service to make sure that the semitrailer is ready for operation, and that conditions affecting the semitrailer's readiness have not changed since the previous after-operation service. The before-operation services specified in table 3-1, Operator/Crew Preventive Maintenance Checks and Services, Chapter 3, must be performed before using the semitrailers.

*b.* You must follow approved practices and precautions. A detailed study of Section III, Operation Under Unusual Conditions, is essential for use of this material under unusual conditions.

#### 2-3. Coupling Semitrailer to Towing Vehicle (Figs. 2-1 through 2-3)

*a.* Back the towing vehicle slowly to the front of the semitrailer. Maneuver the towing vehicle so that the kingpin on the semitrailer is in line with the fifth wheel jaws on the towing vehicle. Before the upper coupler (kingpin) plate of the semitrailer starts to ride on the fifth wheel of the towing vehicle, stop the towing vehicle. Make sure the kingpin and the fifth wheel are properly aligned. Do not ram tractor into semitrailer pick-up plate. You may need to raise or lower the landing legs to align the level of the semitrailer kingpin plate with the tractor fifth wheel. Back towing vehicle under upper coupler (kingpin) plate until the kingpin and fifth wheel hook automatically. Make sure the kingpin and fifth wheel are engaged and locked.

*b.* Remove dummy couplings from the service air couplings and emergency air couplings (fig. 2-1). Couple the towing vehicle air line marked SERVICE and the air line marked EMERGENCY to the semitrailer coupling bearing a like tag.

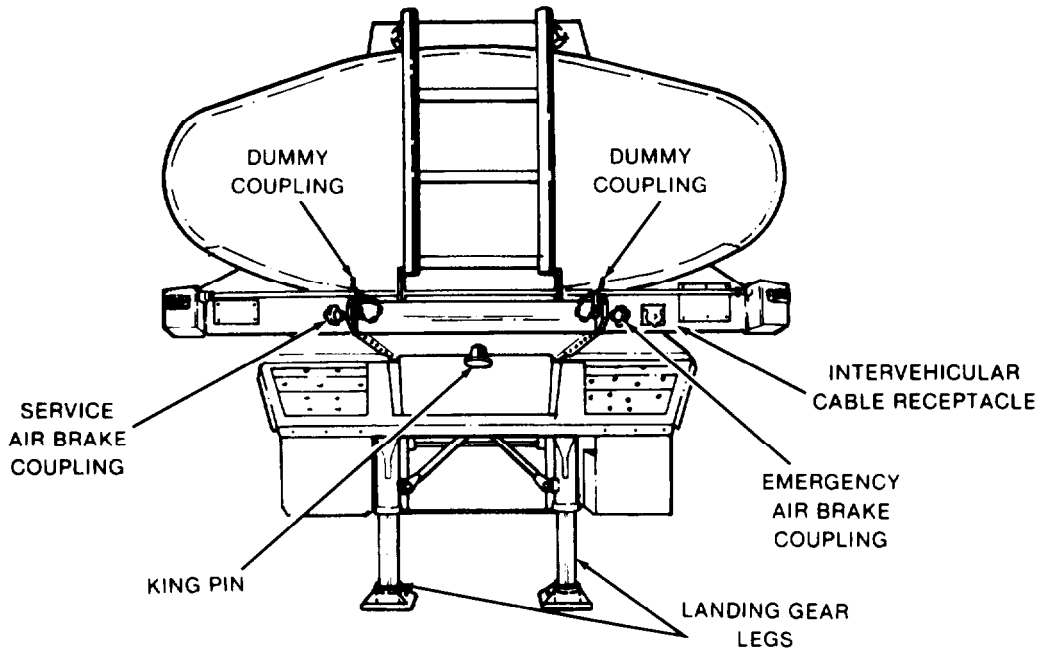

Figure 2-1. Connections Used in Coupling Semitrailer to Towing Vehicle.

TA502253

**CAUTION**

Proper operation of semitrailer primary brake system is essential for safe operation of vehicle. Functional system check is necessary before putting trailer into service. Semitrailer parking brakes are provided to maintain braking and holding requirements whether semitrailer is fully loaded or empty. The system will automatically apply the parking brakes when air pressure in primary reservoir falls below specified pressure. Proper operation of this system must be maintained.

c. Close the drain valves on front and rear reservoir tanks (fig. 2-2). Open the shut-off valves on the air lines of the towing vehicle.

d. Plug the intervehicular cable into receptacle (fig. 2-1) on semitrailer. Operate lights from towing vehicle to make sure that all semitrailer lights are working properly.

e. Release the landing gear operating crank (fig. 2-3) from its clip and engage the crank on its shaft. When there is no load, pull out on the crankshaft to engage high-speed gears for fast raising or lowering of the telescoping legs. When greater power is needed, push in on the operating shaft to engage the low-speed gears to lower or raise the legs. Rotate the crank clockwise to raise the landing gear legs. Replace crank in clip.

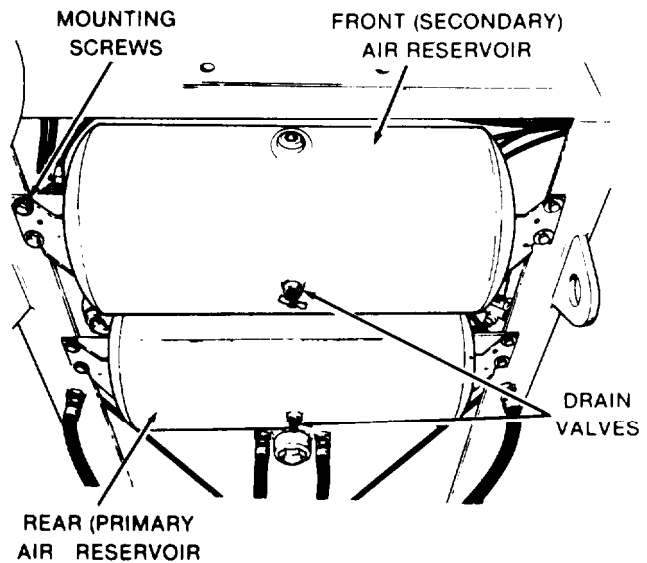
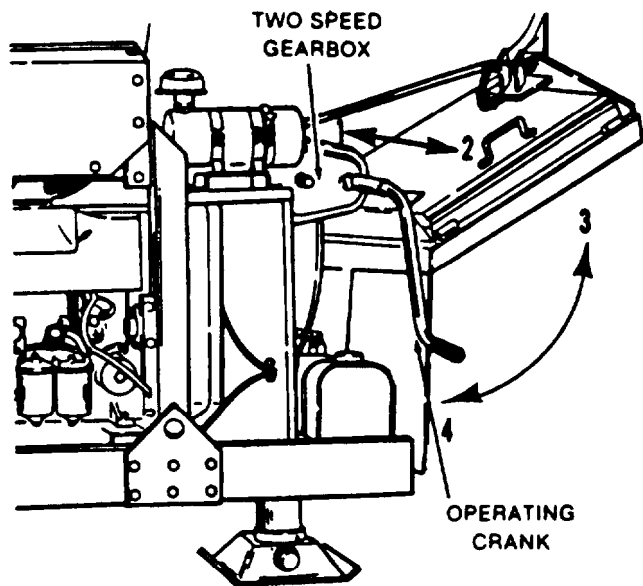

Figure 2-2. Drain Valves on Air Reservoirs.

TA099685





1. Push crank IN for low speed operation.
2. Pull crank OUT for high speed operation.
3. Rotate crank counterclockwise to lower landing gear legs.
4. Rotate crank clockwise to raise landing gear legs.

TA502281

Figure 2-3. Operation of Two-Speed Landing Gear.

f. If coupling to an M931A1 or M932A1 towing vehicle, secure sand shoes in a swing-a-way position rearward to the semitrailer, using chain "assembly provided.

g. If ground boards were used, stow them in their brackets at each side of semitrailer (fig. 2-2).

2-4. Release of Fail-Safe Brakes

NOTE

**On M970 and M970A1, brakes will not release unless hose reel cabinet is closed.**

a. *Reserve Air Release.* If semitrailer is to be moved by other than a towing vehicle, push brake release plunger on roadside of semitrailer to release fail-safe brakes (fig. 2-4). Air in the front reservoir allows the brakes to release twice. When pressure falls under 55 pounds, the air reservoir must be recharged either by connecting air lines to tractor or by using a standard air hose and filling reservoir through filler valve (fig. 2-4). When filling through filler valve, only front (secondary) reservoir is filled. Fill to air gage reading of 90-100 psi. A standard tire gage can be used to check the pressure.

b. *Manual Release (Caging) (M967, M969, and M970 except M970 SN TC-0843, TC-0844, and TC-103 thru TC-178) (Fig. 2-5).* To manually release the fail-safe brakes when no air is available, use the following procedure:

- (1) Block wheels to prevent semitrailer movement.

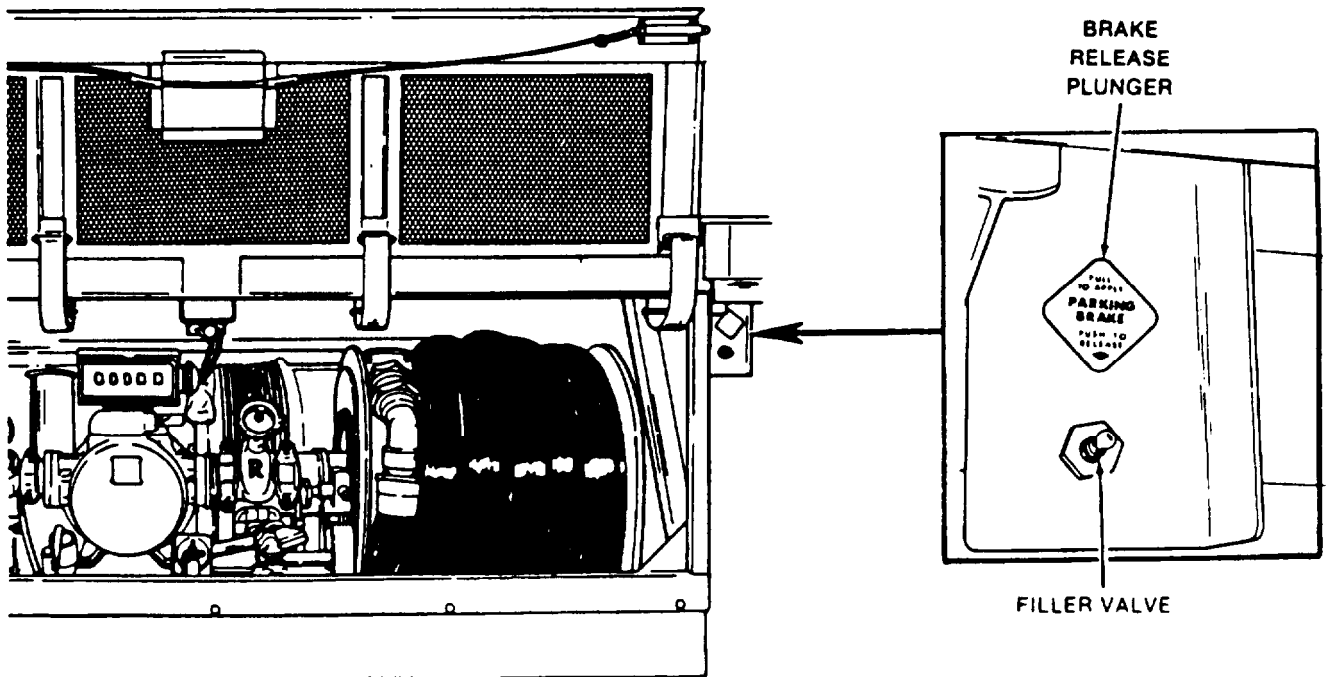

TA099688

Figure 2-4. Location of Brake Release Plunger

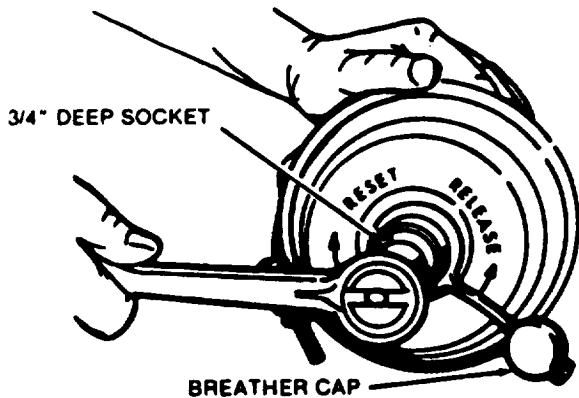

TA099687

**Figure 2-5. Manual Release of Fail-Safe Brake (M967, M969, and M970 except M970 SN TC-0843, TC-0844, and TC-103 thru TC-178).**

(2) Unsnap breather cap from each of the four fail-safe units (fig. 2-5).

(3) Using a  $\frac{3}{4}$ -inch deep socket wrench (Appendix D), turn the manual release bolt counterclockwise until brake shoes are released on each drum.

**CAUTION**

**Do not leave breather caps off any longer than necessary. Water, mud, and other contaminants can harm the operation of the brake actuator. The vent on the breather cap must beat the lowest location pointing down.**

(4) As soon as air is available to refill the reservoirs, turn the manual release bolt clockwise on each of the four fail-safe units until bottomed. Snap breather caps in place.

*c. Manual Release (Caging) (M967A1, M969A1, and M970A1 including M970 SN TC-0843, TC-0844, and TC-103 thru TC-178) (Fig. 2-6).* To manually release the fail-safe brakes when no air is available, use the following procedure:

(1) Block wheels to prevent semitrailer movement.

(2) Remove nut and the release tool from mounting hole in the fail-safe unit (fig. 2-6).

(3) Remove plug.

(4) Insert the release tool into the hole and turn  $\frac{1}{4}$ -turn to seat release tool in pressure plate.

(5) Install nut on release tool, and tighten until  $2\frac{1}{2}$  to  $2\frac{3}{4}$ -inches of release tool is exposed.

(6) Repeat steps (2) through (5) for remaining fail-safe units.

(7) As soon as air is available to refill the reservoirs, remove the release tool and nut from each of the four fail-safe units, and install in mounting hole. Install plugs in place.

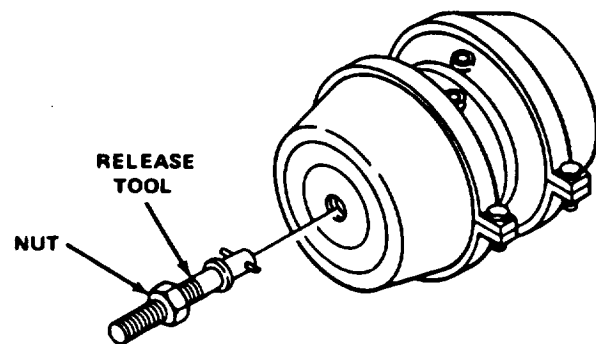

TA221185

**Figure 2-6. Manual Release of Fail-Safe Brake (M967A1, M969A1, and M970A1 including M970 SN TC-0843, TC-0844, and TC-103 thru TC-178).**

**2-5. Operating Towing Vehicle With Semitrailer Coupled**

*a. Driving.* The overall length of the towing vehicle and semitrailer must be kept in mind when passing other vehicles and when turning. Because the unit is hinged in the middle, turning and backing are affected. The surge of the load also affects stopping.

*b. Turning.* When turning corners, remember that the semitrailer has a shorter turning radius than the towing vehicle. To make a right turn at a road intersection, the towing vehicle must continue forward to about the center of the crossroads, and then turn sharply to the right to allow for the shorter turning radius of the semitrailer. If back the semitrailer to the right, turn the steering wheel of the towing vehicle to the left or counterclockwise. The front of the semitrailer will be pushed to the left, and the semitrailer wheels will steer to the right.

*c. Stopping.* In normal operation, the brakes of the towing vehicle and those of the semitrailer are applied at the same time. Brake pressure should be applied gradually and smoothly. On steep grades and slippery surfaces, the semitrailer brakes should be applied first; then the brakes of the towing vehicle should be applied. This procedure will reduce the possibility of the semitrailer "jack-knifing".

**CAUTION**

**Never use the air brakes on the semitrailer when parking if the brake drums are hot. The brake drums will contract (shrink) as they cool and may crack as the applied brakes prevent normal contracting.**

d. *Parking.* When the towing-vehicle-with-semitrailer combination is to be parked and left unattended, set the hand brake firmly.

**2-6. Uncoupling Semitrailer From Towing Vehicle**

a. If the semitrailer is to be uncoupled in mud, sand, or snow, or if the towing vehicle is an M931A1 or M932A1, position ground boards approximately centered beneath landing gear shoes.

b. Close the shut-off valves on the service and emergency air lines at the rear of the towing vehicle. Uncouple the two air brake hoses from the air brake hose couplings on the semitrailer (fig. 2-1). The semitrailer brakes will set automatically when the emergency air brake hose is uncoupled. Fit dummy couplings on semitrailer air brake hose couplings. Open drain valves on front and rear reservoirs (fig. 2-2).

c. Disconnect intervehicular cable from receptacle on semitrailer (fig. 2-1).

d. If sand shoes are secured in a swing-a-way position rearward to the semitrailer, release chain assembly.

e. Release the landing gear operating crank (fig. 2-3) from its clip, engage crank on shaft, and rotate the crank counterclockwise to lower the landing gear (para 2-3) until the foot pads are firmly on either the ground or the ground boards. Replace the crank in its clip and secure.

f. Release the semitrailer kingpin from the towing vehicle's fifth wheel hook by pulling out on the lockjaw handle. If the hook is binding and will not release, pull the hook handle harder to force release. Drive the towing vehicle forward until the semitrailer is disengaged from the towing vehicle and is resting on its landing gear.

**2-7. Jacking Procedures**

A jack is not part of the on-vehicle equipment. If you have to change a flat during operations, use the towing vehicle jack. Place jack under axle on side of semitrailer with the flat tire. Jack up axle until both tires on that end of axle clear the ground. Replace flat tire and wheel with spare tire and wheel. When lug nuts have been put on and tightened, lower wheels and remove jack. Recheck lug nuts for tightness, and stow jack in towing vehicle.

**Section II. OPERATION OF AUXILIARY EQUIPMENT**

**2-8. General Instructions - Fuel Handling (All Models)**

**WARNING**

**Follow all fuel handling procedures precisely to prevent injury or death to personnel.**

a. *Safety Precautions.* It is important that all fuel handling and operating procedures be followed precisely. A detailed study of FM 10-20, FM 10-68, FM 10-69, and FM 10-71 is essential for all fuel servicing operations.

**WARNING**

**Ensure that grounding connections are made properly and firmly before any fueling operations begin. This will ensure that grounding connections will not release, thus eliminating the possibility of sparks caused by static electricity which will ignite the fuel.**

**WARNING**

**Ladder has narrow tread. Use care when climbing.**

**NOTE**

**Always connect a static ground line to the vehicle, storage facility, aircraft, or equipment being serviced. If portable ground is used, make sure a good connection is made.**

b. *Bonding and Grounding (Fig. 2-7).*

(1) Bonding is electrically connecting units or containers both to equalize any static potential that might exist before operations begin and to provide a continuous path for any static electricity that might be generated after operations begin.

(2) Grounding is electrically connecting single or bonded units to a ground rod to discharge into the earth any static potential that might already exist or that might be generated.

(3) If two or more units are bonded, and one is grounded, the whole system is effectively grounded.

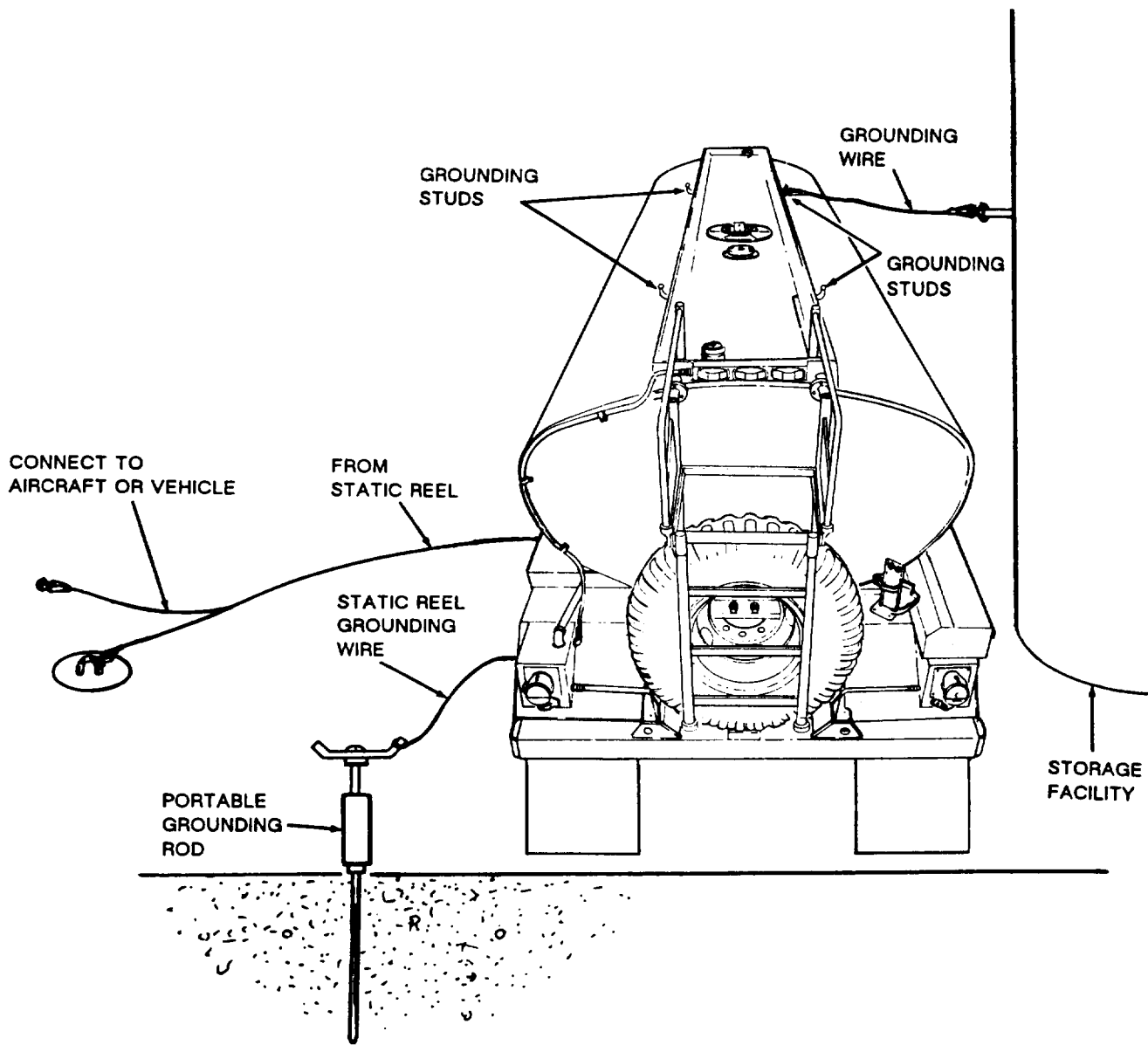

TA502254

Figure 2-7. Typical Ground Connections.

(4) Follow bonding and grounding procedures presented in specific paragraphs on loading, transfers, and dispensing.

(5) Before performing maintenance on semitrailer, semitrailer must be grounded to an approved (earth) ground.

c. *On-vehicle Equipment.* Before each operation, check on-vehicle equipment for completeness. If parts are

missing, vehicle is considered not ready for operation. On-vehicle equipment consists of the items in Section III of Appendix C.

d. *Fire Extinguishers.* During all fuel servicing operations, the fire extinguishers must be removed from their stowage brackets and brought to the point of operation. Replace fire extinguishers and covers when fuel servicing is completed.

**CAUTION**

**Operator(s) must be alert for leaking and malfunctioning equipment. Stop all servicing operations immediately at the first sign of leaks or malfunctions. Corrective action must be performed by qualified technicians before resuming any operations.**

*e. Spills and Leaks.* All spills must be cleaned up immediately. Suitable containers must be placed under hose connections and similar locations to collect leakage or spills.

*f. Vapor Recovery.* A vapor recovery kit can be installed on all models (para 1-9). The arrangement of the vapor recovery system is shown in figure 2-8.

**2-9. Engine Controls and Instruments**

The engine control panel (fig. 2-9) is located on the roadside of the semitrailer, above the piping assembly (figs. 2-11 and 2-12). Control functions and gage readings are explained in the following paragraphs.

*a. Preheater Switch.* Connects battery voltage to glow plugs in engine intake manifold to preheat the engine. (Engine switch, item b, must be in RUN position.)

*b. Engine Switch.* In RUN position, energizes engine electrical system and fuel pumps to permit engine operation. STOP position cuts off fuel supply and stops the engine.

*c. Indicator Light.* This should turn on when Preheater Switch is turned to ON position. If light does not come on, it indicates there is no current flow to the manifold heaters and glow plugs.

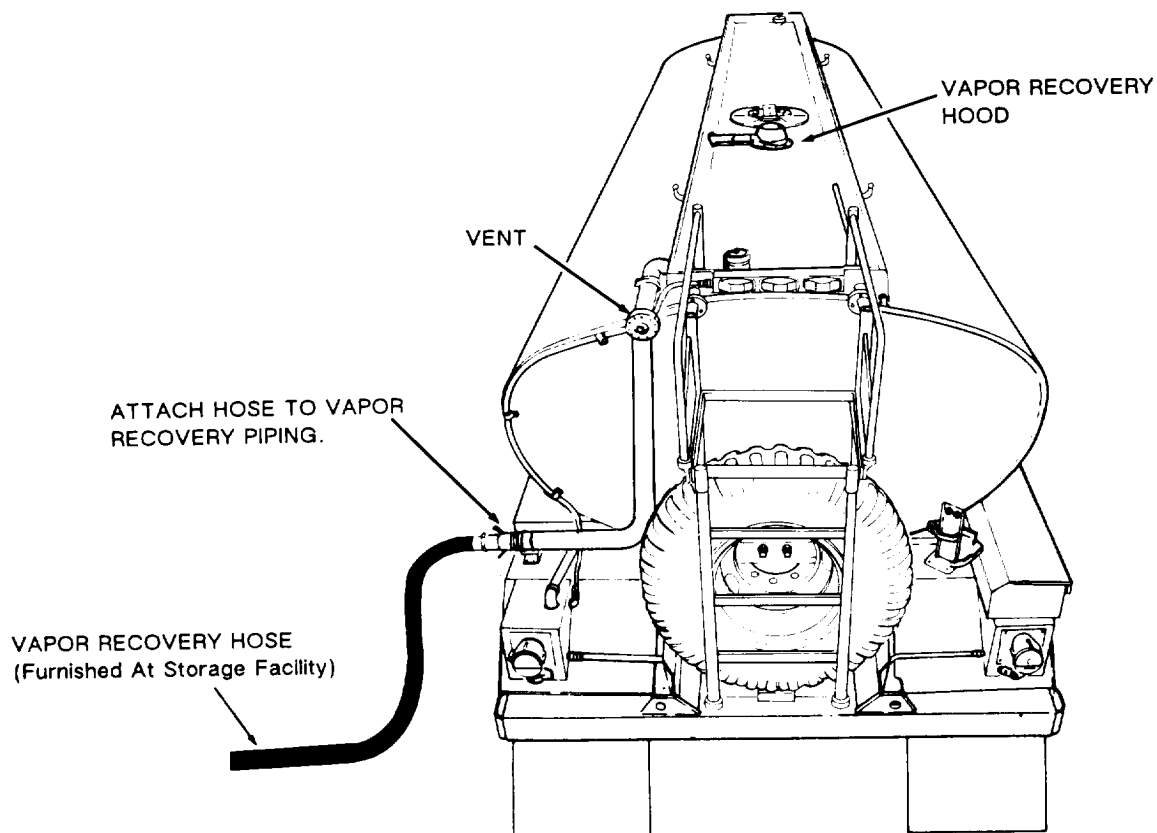

**Figure 2-8. Typical Vapor Recovery System.**

TA502255

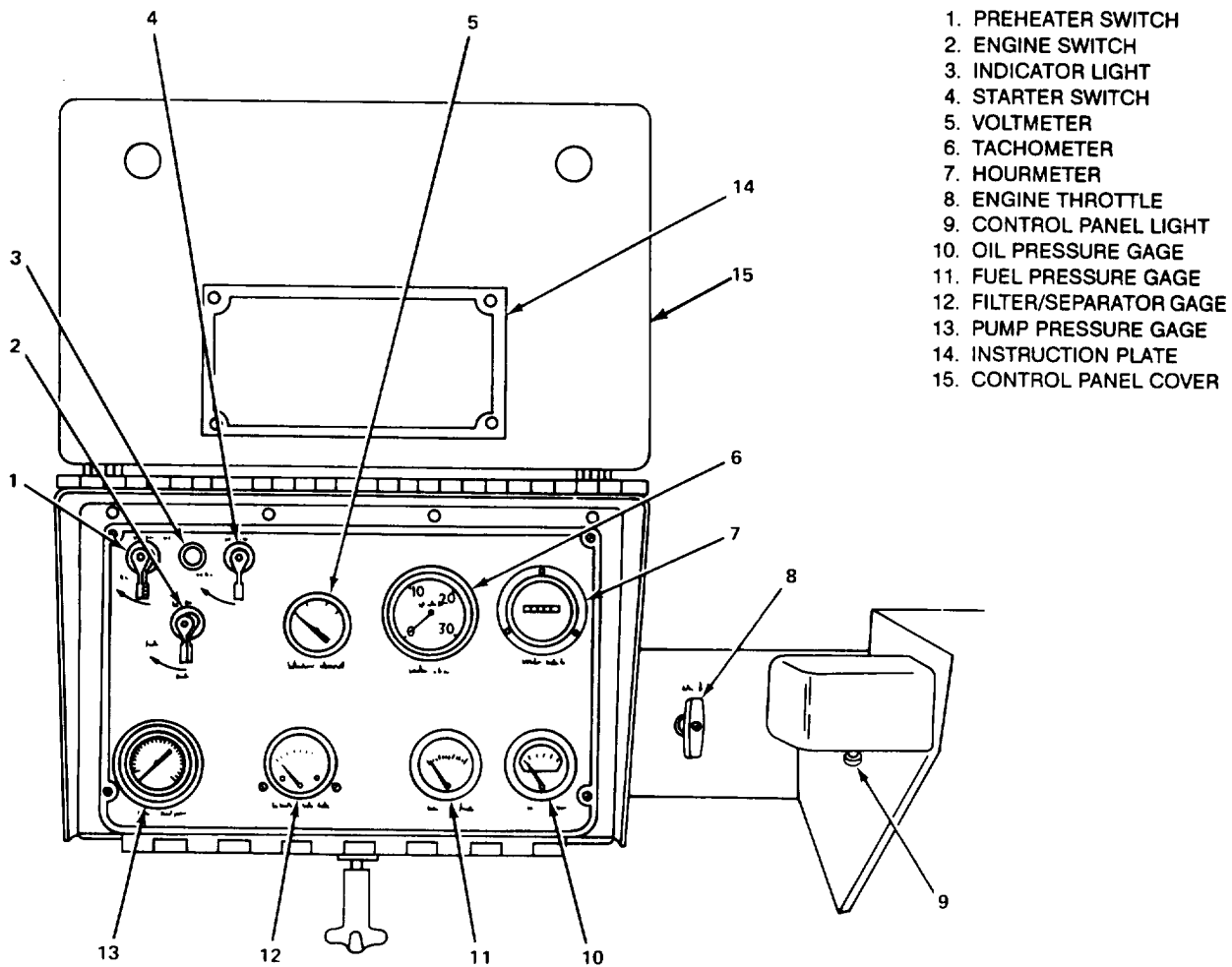

1. PREHEATER SWITCH
2. ENGINE SWITCH
3. INDICATOR LIGHT
4. STARTER SWITCH
5. VOLTMETER
6. TACHOMETER
7. HOURMETER
8. ENGINE THROTTLE
9. CONTROL PANEL LIGHT
10. OIL PRESSURE GAGE
11. FUEL PRESSURE GAGE
12. FILTER/SEPARATOR GAGE
13. PUMP PRESSURE GAGE
14. INSTRUCTION PLATE
15. CONTROL PANEL COVER

**Figure 2-9. Typical Control Panel.**

TA502256

*d. Starter Switch.* Engages starter motor to turn and start the engine. (Engine switch, item b, must be in RUN position.)

*e. Voltmeter.* Indicates battery operating voltage. Normal indication is 12-14V with engine running.

*f. Tachometer.* Indicates engine rpm and should be used with either Flow Rate/rpm data plate (para 1-11) or table 2-2 to select desired flow rate.

*g. Hourmeter.* Indicates engine running time.

*h. Engine Throttle.* Controls and sets engine speed. Pull the handle out to the selected setting, then rotate it clockwise to lock it in position.

*i. Control Panel Light.* To illuminate the control panel, activate the light switch at the bottom of the light.

*j. Oil Pressure Gage.* Indicates pressure in engine lubrication system. Normal indication is 30-40 psi when engine is warm and running.

*k. Fuel Pressure Gage.* Indicates pressure in the fuel injection system. Normal indication is 12-14 psi.

*l. Filter/Separator Gage (M969, M969A1, M970, M970A1).* Indicates amount of restriction in filter/separator (para 2-15).

**NOTE**

**Pressure will vary. The engine speed, type of operation, and nozzles used have a direct effect on pump pressure.**

*m. Pump Pressure Gage.* Indicates pressure in the pump discharge line. Normal operating pressure is 30 psi

for the 4-inch low-head pump (M967, M967A1, M969, and M969A1) and 65 psi for the 3-inch high pressure pump (M970 and M970A1).

**2-10. Engine Operation**

a. *Prior to Starting Engine.* The following precautions must be taken:

**WARNING**

Before and after fuel servicing operations, all valves are to be in the closed position. Failure to follow this warning could result in excessive spillage and create a fire hazard.

(1) Make sure all manually operated valves are closed. This is a must before either starting or ending any fuel servicing operation.

(2) To prevent collapse of tank when filling or emptying tank, ensure that the top vent is working properly (para 2-11f).

(3) Open only those valves required to perform a specific operation. All other valves must remain closed. Close all valves again after completing the operation.

b. *Before Operation.* Before starting engine, the following checks and services should be performed:

(1) Remove fuel tank cap (fig. 2-10) and check fuel supply. Fill with No. 1 diesel fuel (item 15, Appendix E) or arctic diesel fuel (item 13, Appendix E) for operation below 32°F. Use No. 2 diesel fuel (item 14, Appendix E) for operation above 32°F. Tank capacity is approximately 4 gallons.

(2) Pull oil dipstick (fig. 2-10) and check oil level. If oil dipstick reads L (low), add one quart to bring oil to F (full) mark. If below L mark, add one quart at a time until dipstick reads F. For oil specifications, see figures 3-1 through 3-6.

(3) Check air cleaner restriction indicator (fig. 2-10) for a red band showing in indicator window. A red band showing indicates that the engine air cleaner is dirty. Clean or replace the air cleaner element (para 3-18).

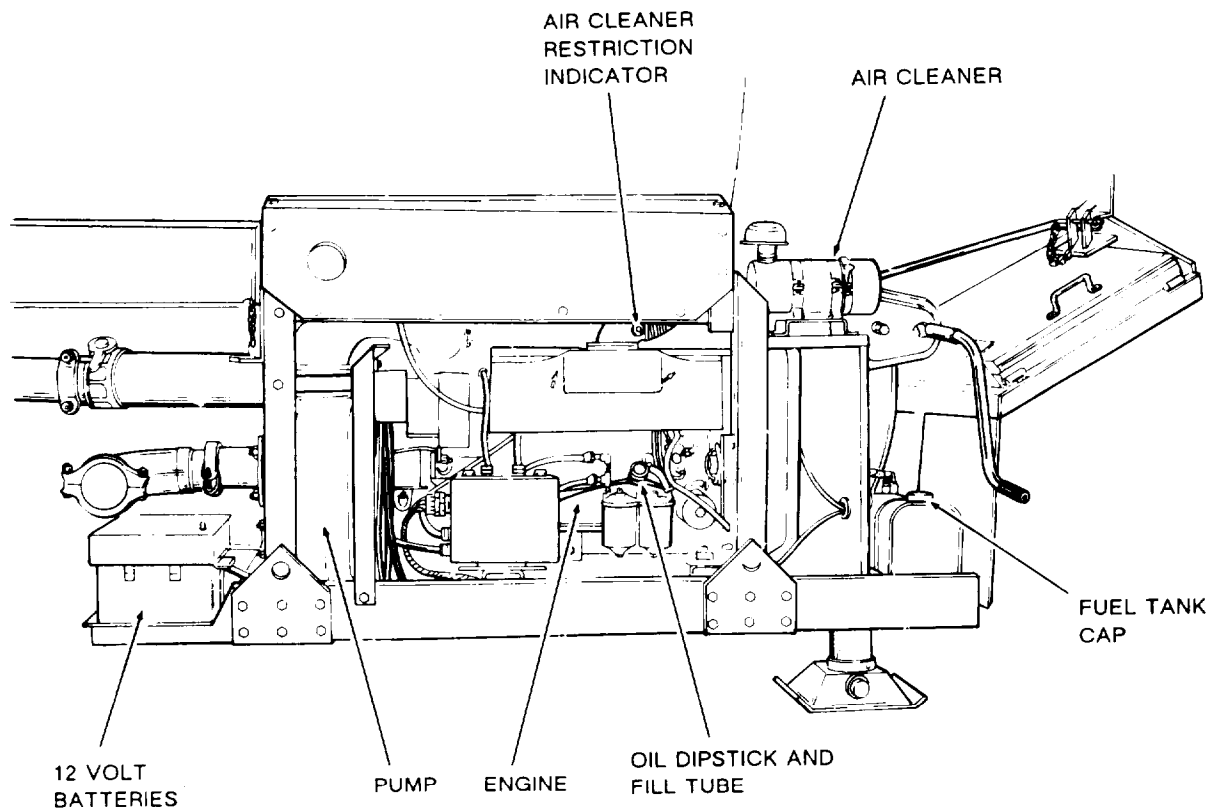

Figure 2-10. Engine and Pump Assembly.

TA502257

**WARNING**

- **Carbon monoxide can be deadly. DO NOT operate engine in an enclosed area unless it is adequately ventilated.**
- **Operators must wear ear protection while on engine side of semitrailer with engine running. Failure to follow this warning may result in injury to personnel.**

c. *Starting Engine.* This procedure is for starting a cold engine in temperatures above 55°F (fig. 2-9).

- (1) Rotate engine switch (2) to RUN.

**NOTE**

**When engine is warm or restarted after short periods of time, preheating is usually not necessary. In temperatures below 30° F, a longer preheating period is needed (para f).**

- (2) Rotate preheater switch (1) to ON for about 1 minute. Ensure indicator light (3) has illuminated.

- (3) After 1 minute, continue to hold preheater switch and rotate starter switch (4) to START

- (4) Release both starter switch and preheater switch after engine starts.

- (5) Check the gages for correct indication. Stop the engine if a system malfunction is indicated.

d. *Stopping Engine.*

**CAUTION**

**Throttle engine to fast idle (1200 rpm) for about 5 minutes before stopping to allow for gradual cooling of engine.**

- (1) Release throttle to low idle.
- (2) Rotate engine switch (2, fig. 2-9) to STOP.

e. *Engine Operation — High Temperature.*

- (1) See that nothing obstructs the air flow to and from the engine oil cooler and the cylinder cooling fins.

- (2) See that all shrouds are properly installed and in good condition.

f. *Engine Operation - Low Temperature.*

**NOTE**

**If operating in cold weather, cover (dust boot) of fuel stop solenoid must be cut off. Cover stiffens in cold temperatures and stops flow of fuel to engine.**

- (1) Ensure that the engine has the proper oil and fuel for the existing temperatures. For fuel specifications, see paragraph 2-10b. For oil specifications, see figures 3-1 through 3-6.

- (2) Keep batteries fully charged.

**NOTE**

**Entire cold weather starting procedure may not be required. The colder the temperature, the more preheating and cranking will be required.**

- (3) Cold Weather Starting. When temperatures are below 30°F, use the following procedure to start the engine (fig. 2-9).

- (a) Pull throttle about half way out.

- (b) Engage preheater switch (1) and leave turned on until engine has started, approximately 5 minutes at coldest temperature.

- (c) After 1 3/4 minutes, move engine switch (2) to RUN position. Wait 15 seconds, then engage starter switch (4) to START position and crank for 15 seconds. Disengage starter switch.

**NOTE**

**DO NOT disengage starter switch (4) at first firing of engine. Continue with switch engaged for a limited time (30 seconds maximum) to help engine run and gain speed.**

- (d) Wait one minute and engage starter switch (4). Crank for one minute, or until running, then disengage starter switch.

- (e) If engine has still not started, engage starter switch (4) and crank for one minute. Engine should be firing. Disengage starter switch when engine is increasing speed.

- (f) Turn off preheater switch (1).

**2-11. Identification of Valves, Piping, and Dispensing Components**

The operator/crew should become thoroughly familiar with all valves and controls before beginning any fuel servicing operation. Compare figures 2-10 through 2-15



with the piping schematic, mounted on the tool box cover, for each model.

a. *Piping Control Assembly.* This assembly contains a 4-inch pilot-operated control valve, plus the following components (figures 2-11 and 2-12):

(1) *Valve A, Emergency Valve Operator (All Mode/s).* Mechanically controls both the emergency valve on the outlet sump and the vapor vent on top of semitrailer.

(2) *Valve B (All Models).* Fastened to the rear manifold. Controls the opening for bulk delivery connections.

(3) *Valve C (M970, M970A1).* Attached to the rear manifold. It is a check valve controlling the opening for defueling operation.

(4) *Valve D, Precheck (All Models).* Fastened to the frame above the piping control assembly. Provides a way to check the shut-off float for proper functioning. (para 2-11g).

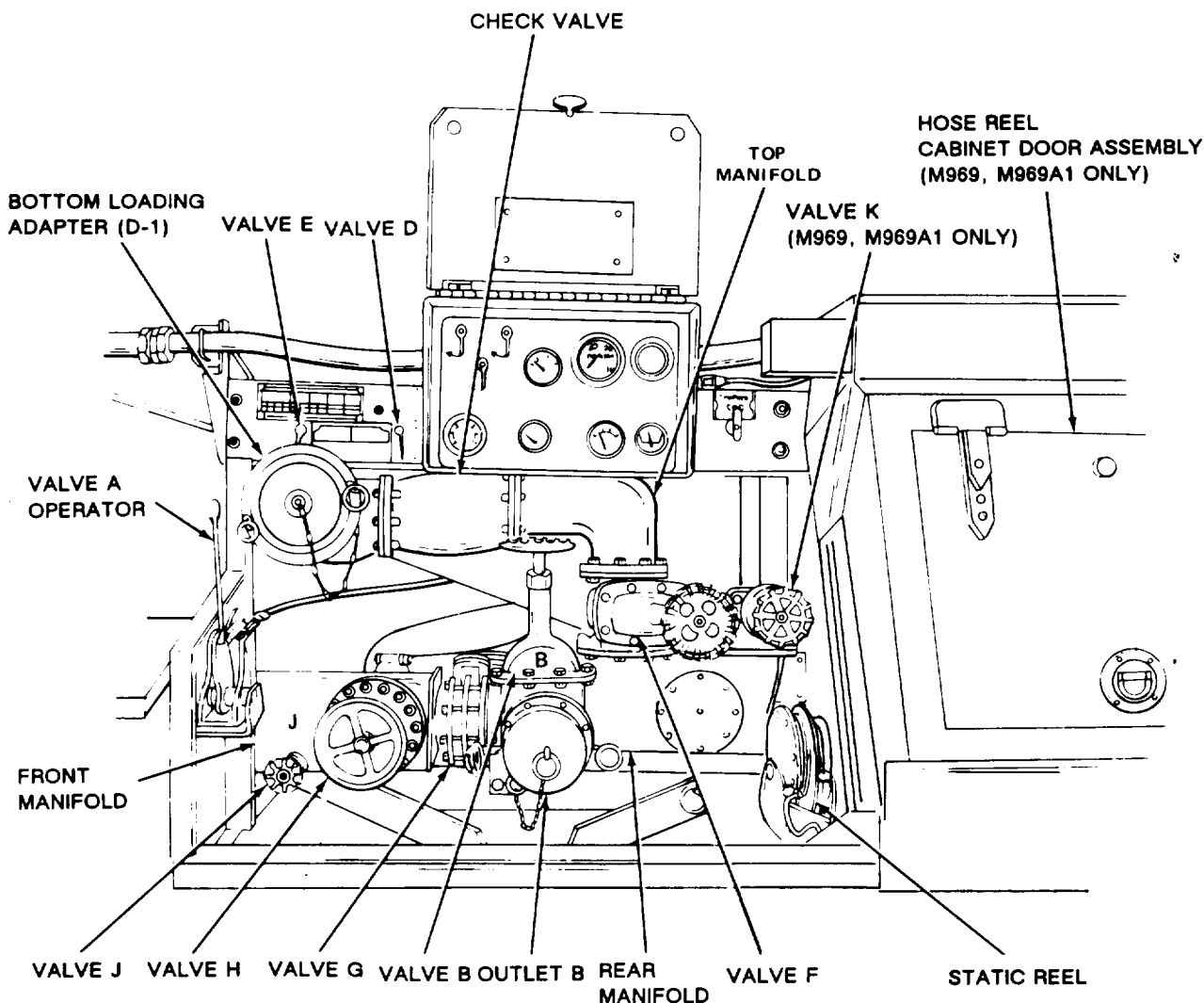

**Figure 2-11. Piping Assembly and Valve Locations (M967, M967A1, M969, and M969A1) (M969 and M969A1 Arrangement Shown).**

TA502258

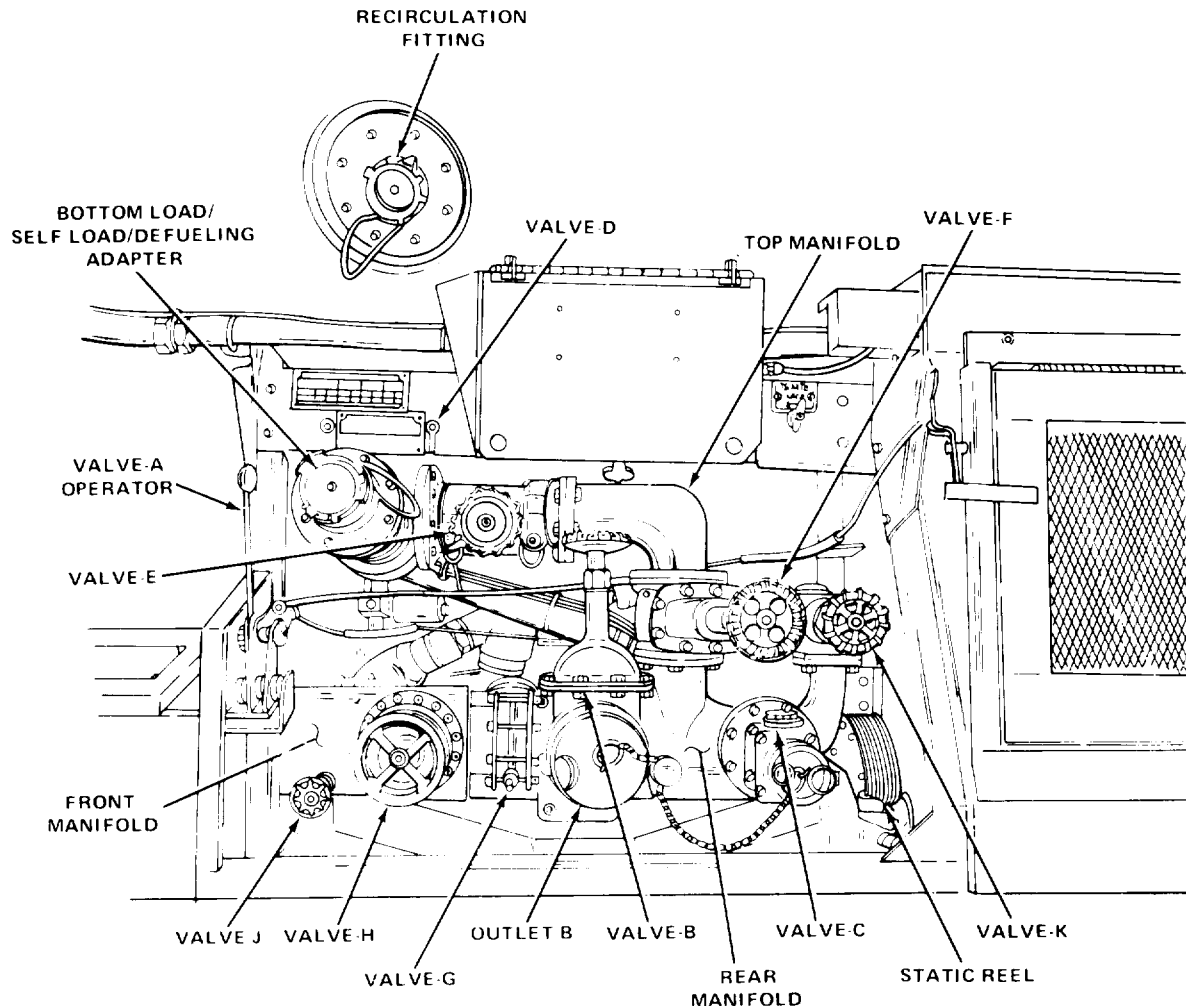

TA221174

**Figure 2-12. Piping Assembly and Valve Locations (M970 and M970A1).**

(5) *Valve E (M967, M967A1, M969, M969A1).* Located next to the precheck valve (D). Provides load/unload selection (para 2-11h).

(6) *Valve E (M970, M970A1).* Allows evacuation of fuel from the dispensing systems.

(7) *Valve F (All Models).* Opens the pump outlet line to permit bulk fuel delivery (nonfiltered).

(8) *Valve G (All Models).* Located between the front and rear manifolds. Permits gravity unloading and self-loading. Valve is open when handle is parallel to pipe.

(9) *Valve H (All Models).* Located in the front manifold. Permits fuel flow through the manifold to the pump.

(10) *Valve J (All Models).* Allows water drain of the front manifold.

(11) *Valve K (M969, M969A1, M970, M970A1).* On the rear manifold. Allows fuel flow between the bulk delivery connections and the filtering/dispensing system.

**WARNING**

**DO NOT let go of static reel cable when rewinding until the ball stop is firmly touching the reel. Failure to follow this warning may cause injury to personnel.**

(12) *Static Reel.* The static ground cable is pulled from the static reel and attached to unit being serviced, and to a ground plug, stud, or clamp. The reel has an automatic locking device which engages when cable is extended to the desired length and releases when cable is pulled out again. The reel is spring loaded to rewind automatically.

b. *Filter/Separator (M969, M969A1, M970, and M970A1).* Two valves are located near the filter/separator (fig. 2-13).

(1) *Valve M.* Controls fuel flow from the pump outlet to the inlet of the filter/separator. Valve is open when handle is parallel to pipe.

(2) *Valve N.* The manual drain for the sump on the filter/separator.

c. *Hose Reel Cabinet (M969, M969A1, M970, and M970A1).* Contains the following valves and components (figs. 2-14 and 2-15):

(1) *Valves P and R.* Permit fuel flow through the hose reels.

(2) *Valve S (M970 and M970A1), Deadman Control.* A hand-held valve that operates a shut-off valve (3-inch control valve) in the hose reel supply line. It is only used when the 2½-inch hose is in service. The reel has an automatic locking device which engages when hoses are

extended to the desired length and releases when hoses are pulled out again. The reel is spring-loaded to rewind automatically.

(3) *Deadman Release Plunger (M970 and M970A1).* This control deactivates the deadman control system after the 2½-inch hose has been used, allowing fuel flow to the 1½-inch hose.

#### NOTE

**On the M969 and M969A1, an Aqua-Glo probe and fuel-sampling adapter may be installed on outlet nipple of both or either meter. This installation provides a port downstream of filter/separator to draw fuel samples for water (Aqua-Glo) test.**

(4) *Meter(s).* The M970 and M970A1 are equipped with a single meter. The M969 and M969A1 are equipped with two meters. To reset the meter to zero, push the meter reset knob in and turn clockwise.

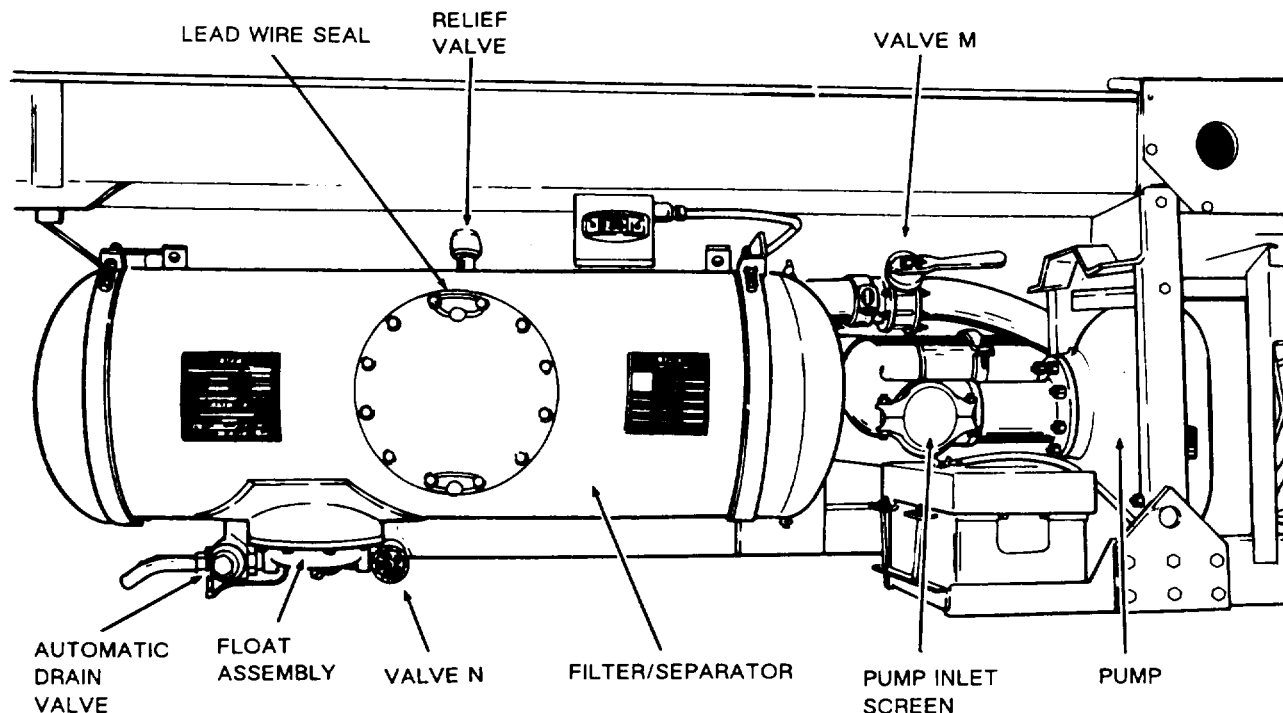

Figure 2-13. Filter/Separator (M969, M969A1, M970, and M970A1).

TA502259

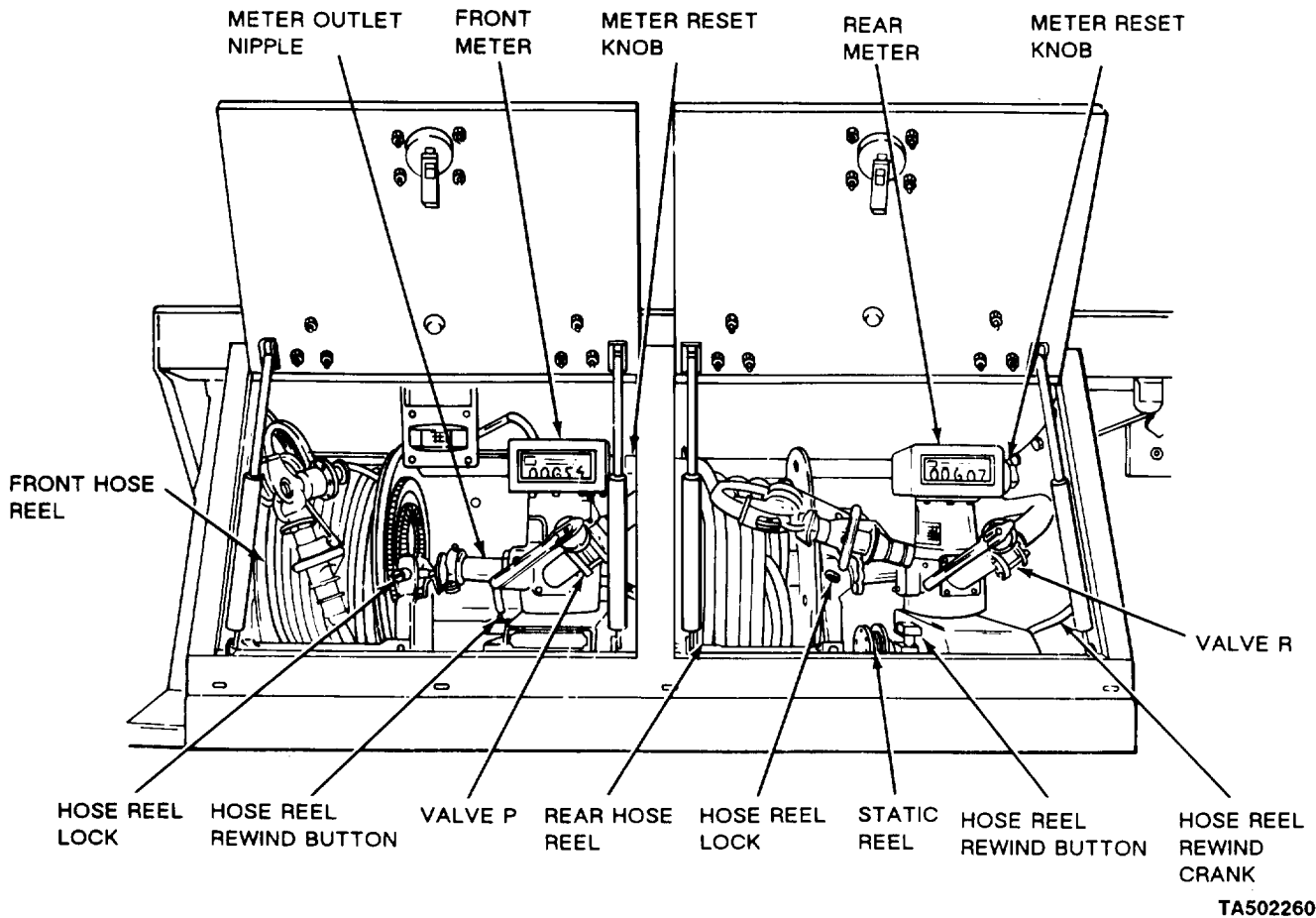

Figure 2-14. Hose Reel Cabinet (M969 and M969A1).

(5) *Hose Reels.* The M969 and M969A1 are equipped with two 1¼-inch hose reels. The M970 and M970A1 are equipped with one 1½-inch hose reel and one 2½-inch hose reel.

(a) *Unwinding Hose.* Release hose reel lock by turning hand wheel on hose reel counterclockwise (figs. 2-14 and 2-15). Pull hose off reel to length required for each fuel service operation.

**WARNING**

**Use extreme caution when operating electric rewind on hose reels. Never use the electric rewind on both hose reels at the same time. Electric rewind should be halted, then resumed carefully as the fuel dispensing nozzle approaches the vehicle. As the hose becomes fully wound on the hose reel, the nozzle may slam against the vehicle with force sufficient to cause injury to persons and/or damage to equipment. Extreme care**

**Is to be used, ensuring that hose is rewound slowly. Caution should be used at the hose reels to prevent accidental tripping of the rewind switches. If these are accidentally depressed by hand or by falling objects, serious injury to persons and/or damage to equipment may occur.**

**NOTE**

**Hose must be evacuated of fuel before rewinding (para 2-14d).**

(b) *Rewinding Hose.* To electrically rewind hose reels, push the hose reel rewind button (figs. 2-14 and 2-15) for the specific hose reel to be rewound. To avoid discharging battery, rewind hose reels while engine is running. To manually rewind hose reels, remove crank from its stowed position in hose reel cabinet, and install on rewind shaft of hose reel. To rewind hose reel on left side of cabinet, turn crank clockwise. To rewind hose reel on right side of cabinet, turn crank counterclockwise. Remove crank and stow in cabinet. Lock hose reel by turning hand wheel clockwise.

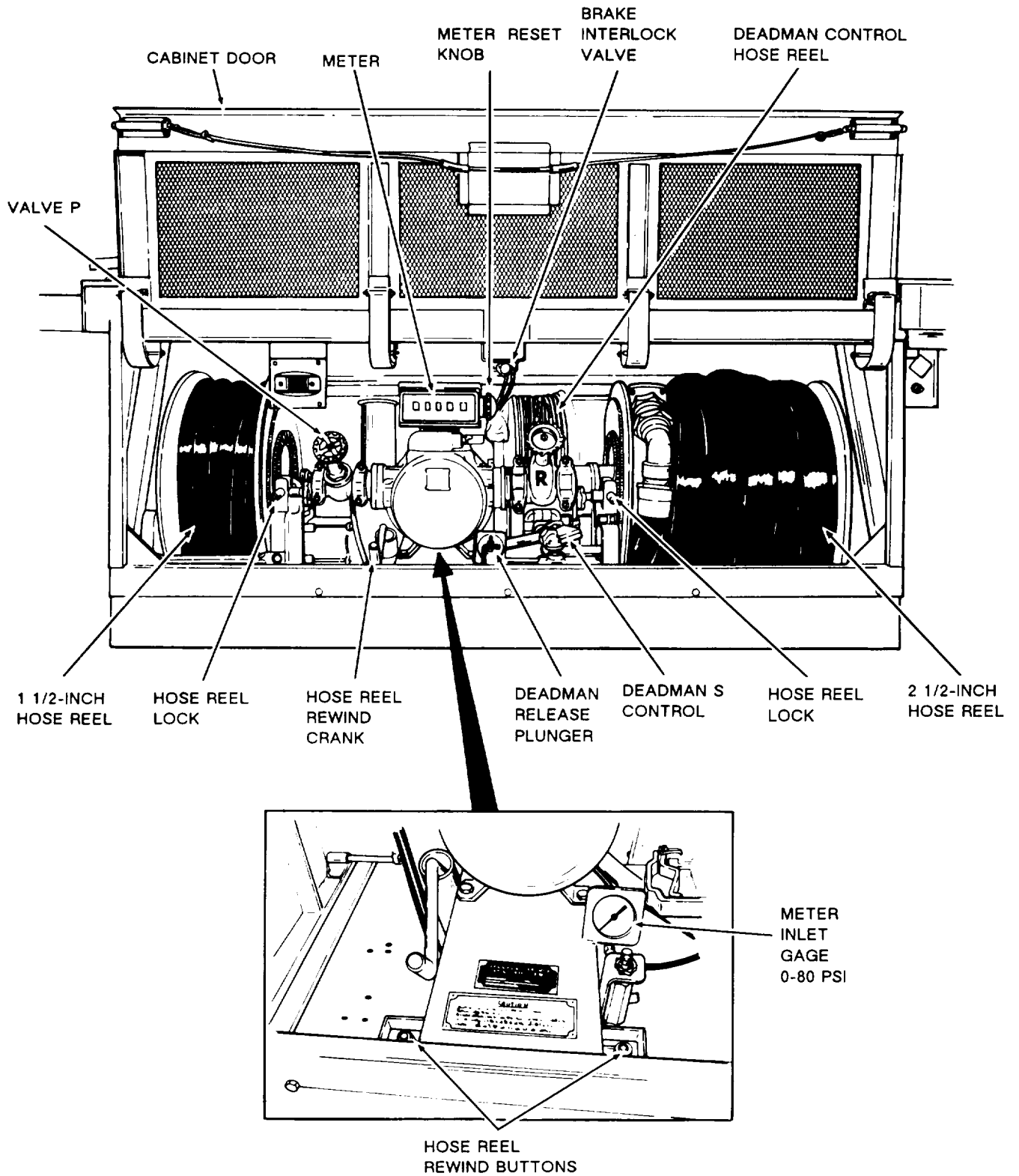

Figure 2-15. Hose Reel Cabinet (M970 and M970A1).

TA099697

**WARNING**

**DO NOT let go of static reel cable when re-winding until the ball stop is firmly touching the reel. Failure to follow this warning may cause injury to personnel.**

(6) *Static Reel (M969 and M969A1).* This static reel in the piping control assembly (para 2-11) is used when two vehicles are being serviced at the same time. The static ground cable is pulled from the static reel and attached both to the unit being serviced and to a grounding plug, stud, or clamp. The reel has an automatic locking device which engages when the cable is extended to the desired length and releases when the cable is pulled out again. The reel is spring-loaded to rewind automatically.

d. *Bulk Fuel Servicing Hoses.* Whenever bulk fuel hose is required, remove the necessary lengths from the hose troughs and couple together as required.

e. *Nozzles.* Make sure hoses are installed with correct nozzles for the operation intended. For M969 and M969A1, contact unit maintenance to install nozzles.

f. *Emergency Valve Operation.* The emergency valve (fig. 2-16) controls the tank outlet. The emergency valve and its related vapor vent are mechanically operated by a lever, operator A, in the piping control assembly (figs. 2-11 and 2-12). Engaging the lever opens the emergency valve to permit fuel flow to/from the tank sump. At the same time, the vapor vent at the top of the tank opens to relieve pressure/vacuum during loading/unloading.

(1) The emergency valve must be open for all loading/unloading operations except top loading.

(2) In an emergency, close the emergency valve by disengaging operator A (roadside of semitrailer) or by pulling emergency valve shut-off (fig. 2-17) (on opposite side).

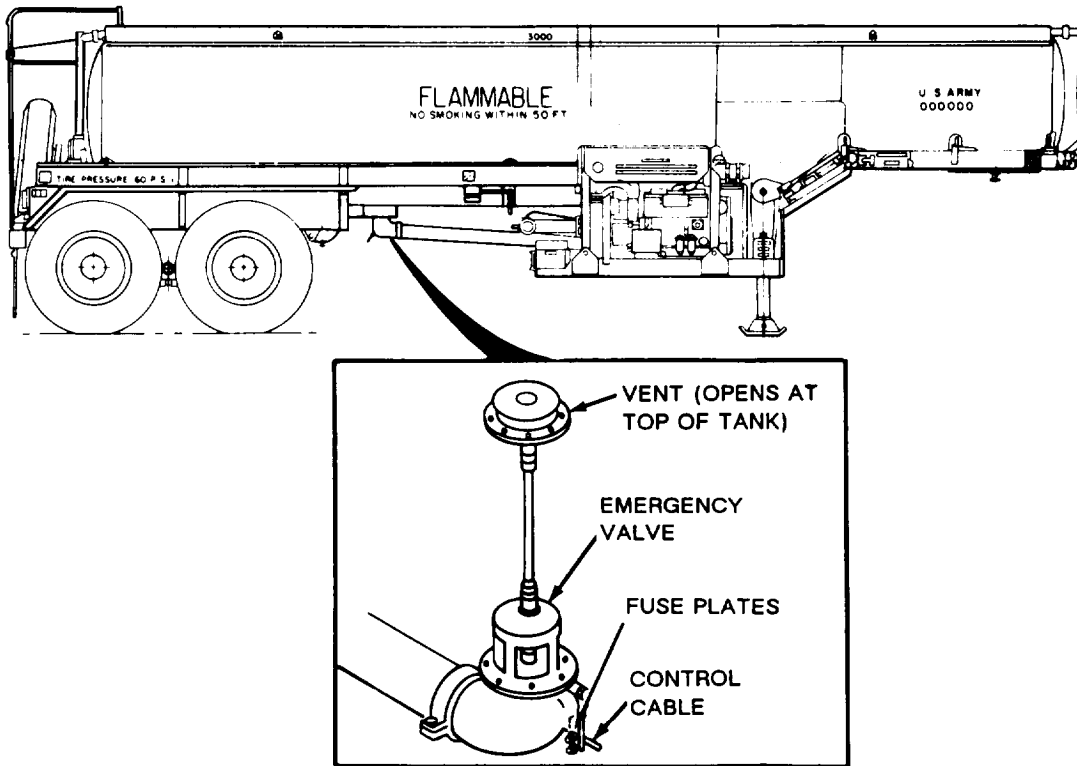

Figure 2-16. Emergency Valve and Vent.

TA502261

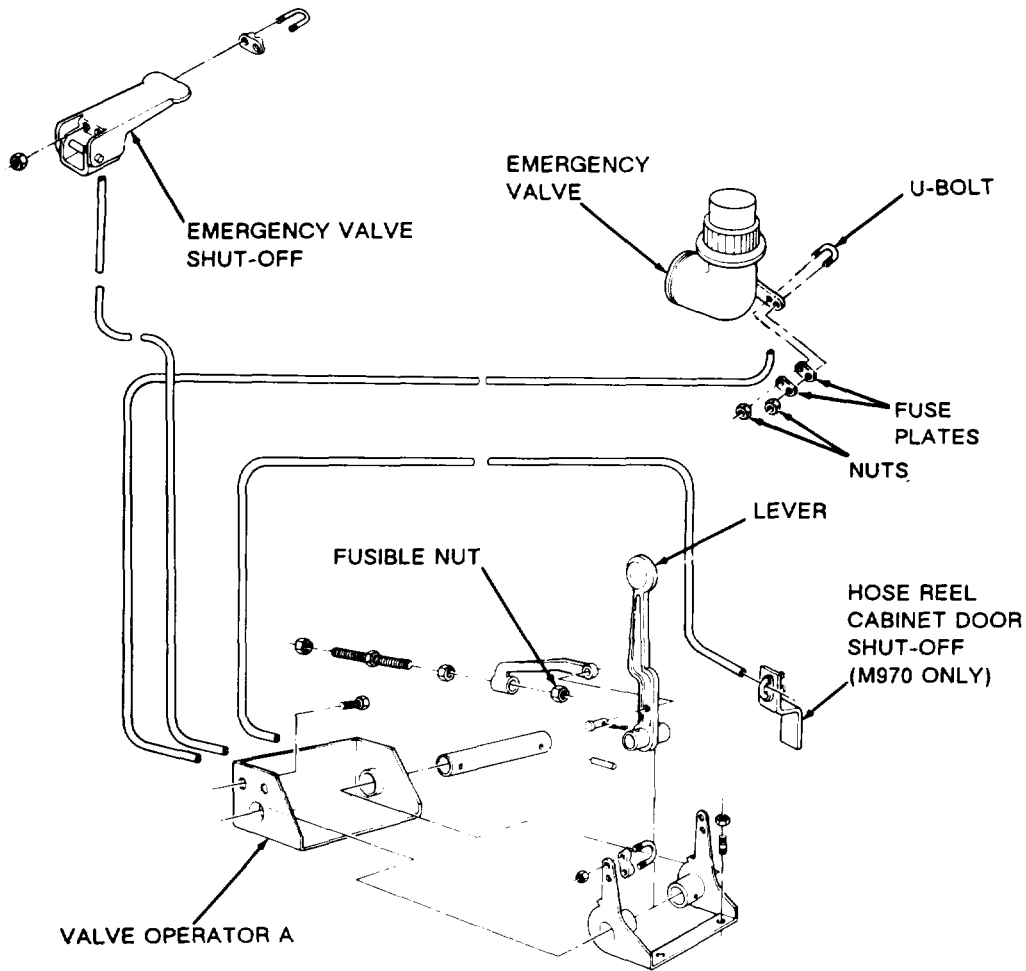

Figure 2-17. Typical Emergency Valve Cable Installation.

TA502262

(3) In event of fire or explosion, either the fusible nut on the emergency valve operator A, or the fuse plates at the emergency valve, will melt, releasing the emergency valve and automatically stopping fuel flow (fig. 2-17).

g. Loading Precheck (All Models).

**WARNING**

**When filling tank by means of bottom loading, defueling (M970 and M970A1 ), or self-loading, a test of the precheck system is mandatory. If this system is not functioning, stop all operations. Determine the problem and have it corrected by a qualified technician. Failure of automatic shut-off to function may result in**

**uncontrolled fuel spillage and danger of fire and explosion.**

(1) Shortly after fuel flow has begun, open precheck valve D (figs. 2-18 and 2-19) to precheck the automatic shut-off. Opening valve D sends fuel to a float valve inside the tank to simulate "full tank" condition.

(2) If float is functional, flow should start after about 20-25 seconds.

(3) Close valve D. Flow will resume in about 20 seconds.

(4) During normal loading through bottom of tank, the shut-off system will stop the incoming flow automatically when fuel reaches the level of the float valve.

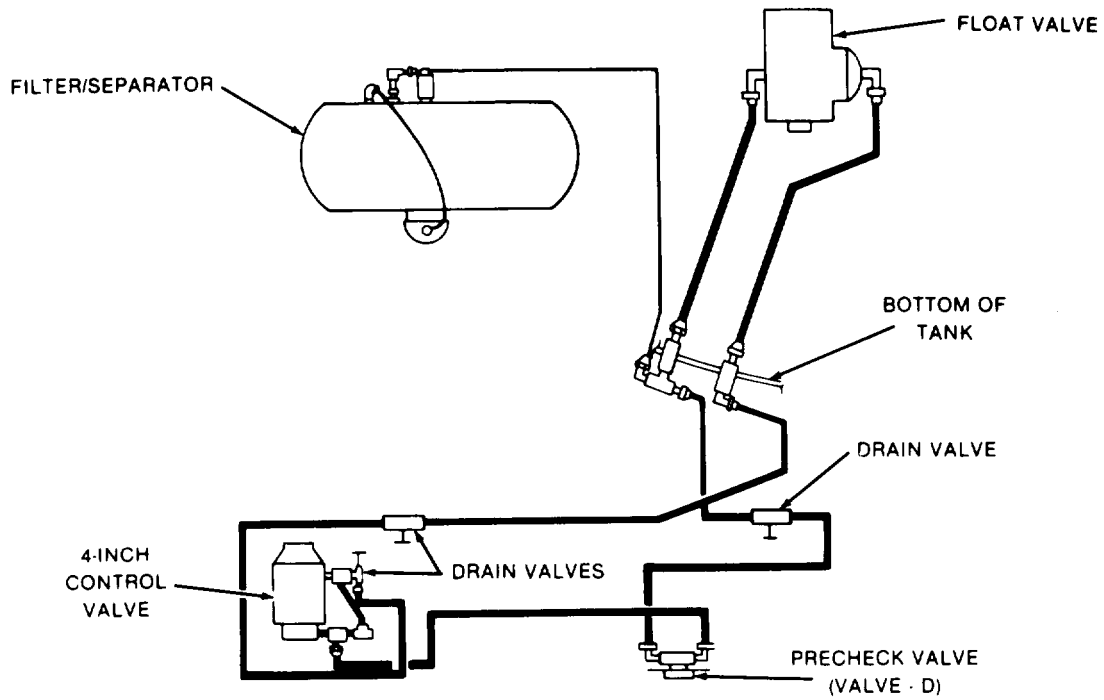

TA099700

Figure 2-18. Arrangement of Precheck System for M970 and M970A1.

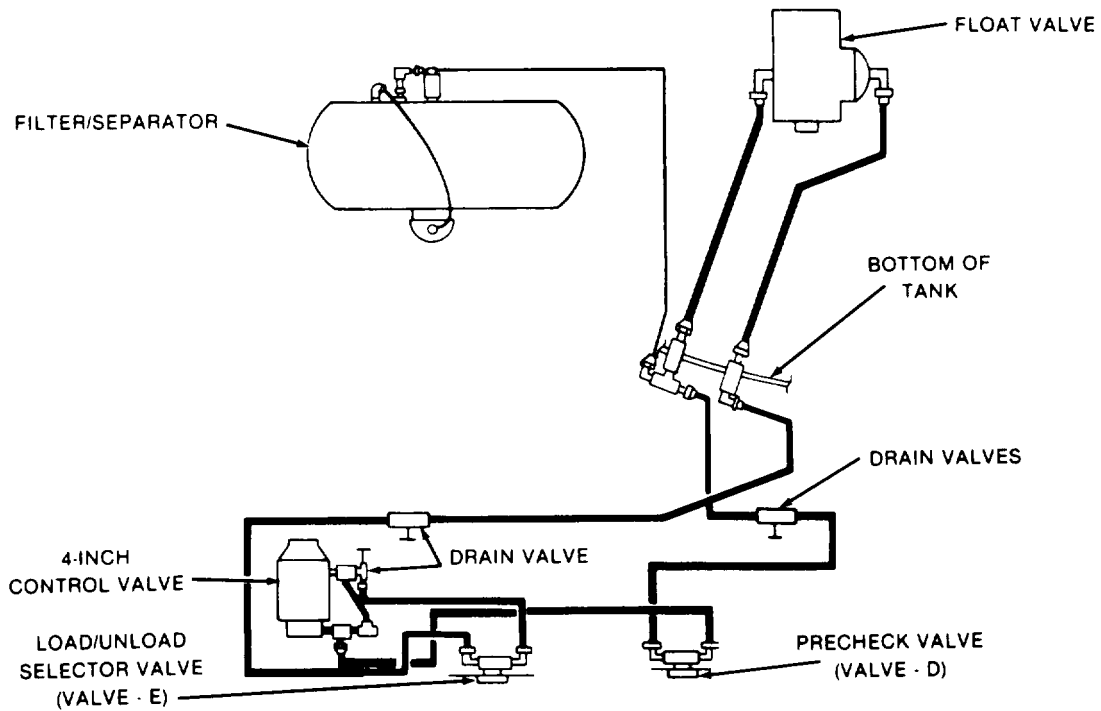

TA099701

Figure 2-19. Arrangement of Load/Unload Selector and Precheck Systems for the M967, M967A1, M969, and M969A1.



h. *Load/Unload Selector (M967, M967A1, M969, and M969A1),*

(1) Before opening any valves for a fuel service operation, ensure that the unload/load selector valve E handle (fig. 2-19) is in the proper position for the fuel servicing operation.

(2) *Load Position.* When selector valve E is in the load position, it directs pilot pressure to the 4-inch control valve for the bottom loading operation.

(3) *Unload Position.* When selector valve E is in the unload position, it shuts off the pilot pressure to the 4-inch control valve. With pilot pressure shut off, the

4-inch control valve closes, eliminating flow through the control valve during bulk delivery and fuel servicing operation.

**2-12. Fueling/Defueling Operations**

**WARNING**

**All fueling/defueling operations must be performed outside.**

a. *Operation Summary.* Refer to table 2-1 for a summary of operations pertaining to your semitrailer.

**Table 2-1. Fueling/Defueling Operation Summary**

---

**M967 and M967A1**

The following operations can be performed with the M967 and M967A1, Bulk Haul, Self-Load/Unload Semitrailer:

**BULK HAUL AND FUEL SERVICING NOT INVOLVING USE OF PUMP AND ENGINE.**

Top Loading	Para 2-13a.
Bottom Loading (Nonfiltered)	Para 2-13b.
Gravity Unload	Para 2-13c.

**NONFILTERED FUEL SERVICING INVOLVING USE OF ENGINE AND PUMP**

Self-Load	Para 2-14a.
Bulk Delivery	Para 2-14b

---

**M969 and M969A1**

The following operations can be performed with the M969 and M969A1, Automotive Fuel Dispensing Semitrailer:

**BULK HAUL AND FUEL SERVICING NOT INVOLVING USE OF PUMP AND ENGINE.**

Top Loading	Para 2-13a.
Bottom Loading (Nonfiltered)	Para 2-13b.
Gravity Unload	Para 2-13c.

**NONFILTERED FUEL SERVICING INVOLVING USE OF ENGINE AND PUMP**

Self-Load	Para 2-14a.
Bulk Delivery	Para 2-14b.
Nonfiltered Dispensing	Para 2-14c.

**FILTERED FUEL SERVICING.**

Filtered Bulk Delivery	Para 2-16a.
Filtered Fuel Dispensing	Para 2-16b.

---

Table 2-1. Fueling/Defueling Operation Summary (Con t).

**M970 and M970A1**

The following operations can be performed with the M970 and M970A1, Aircraft Under/Overwing Fuel Dispensing Semitrailer:

**BULK HAUL AND FUEL SERVICING NOT INVOLVING USE OF PUMP AND ENGINE.**

Top Loading	Para 2-13a.
Bottom Loading (Nonfiltered)	Para 2-13b.
Gravity Unload	Para 2-13c.

**NONFILTERED FUEL SERVICING INVOLVING USE OF ENGINE AND PUMP**

Bulk Delivery	Para 2-14b.
---------------	-------------

**FILTERED FUEL SERVICING.**

Filtered Self-Load	Para 2-17a.
Filtered Bulk Delivery	Para 2-17b.

**AIRCRAFT FUEL SERVICING.**

Fuel Sampling	Para 2-18a.
Aircraft Single Point Underwing Fuel Dispensing	Para 2-18b.
Aircraft Overwing/Closed Circuit Dispensing	Para 2-18c.
Defueling with 2½-inch Hose	Para 2-18d.
Defueling with 1½-inch Hose	Para 2-18e.
Recirculation with 2½-inch Hose	Para 2-18f.
Recirculation with 1½-inch Hose	Para 2-18g.

**WARNING**

**DO NOT mix incompatible fuels in tank. Dangerous fumes and explosion may result. Know what fuel was previously carried so that preventive measures may be taken to ensure that injurious or explosive fumes are not released. Failure to follow this warning may result in injury or death to personnel.**

b. *Changing Fuels.* If fuel to be loaded is not the same fuel as previously carried, refer to FM 10-71, Petroleum Tank Vehicle Operations, for information on purging requirements.

**2-13. Basic Bulk Haul and Fuel Servicing Operations Not Involving Use of Engine and Pump (All Models)**

a. *Top Loading (Fig. 2-21).* The semitrailer should only be loaded through the top manhole when bottom loading is not possible. Bottom loading minimizes the level of static electricity buildup.

**WARNING**

**When top loading through fill cover, there is no automatic shutdown. Man the loading hose to avoid fuel spillage. Use capacity indicator gage and dipstick gage to determine amount of fuel loaded. Failure to follow this warning may result in uncontrolled fuel spillage and a fire or explosion hazard.**

**WARNING**

**Ladder has narrow tread. Use care when climbing.**

- (1) Review general instructions in paragraph 2-8.
- (2) Ensure that all valves are closed.
- (3) Ground the semitrailer tank (para 2-8).

(a) *Loading With Rack or Stand.* Connect the bonding and grounding cable of the loading rack or stand to one of the four grounding studs on top of tank or one of the two on the lower side of the tank (fig. 2-7) before opening fill cover.

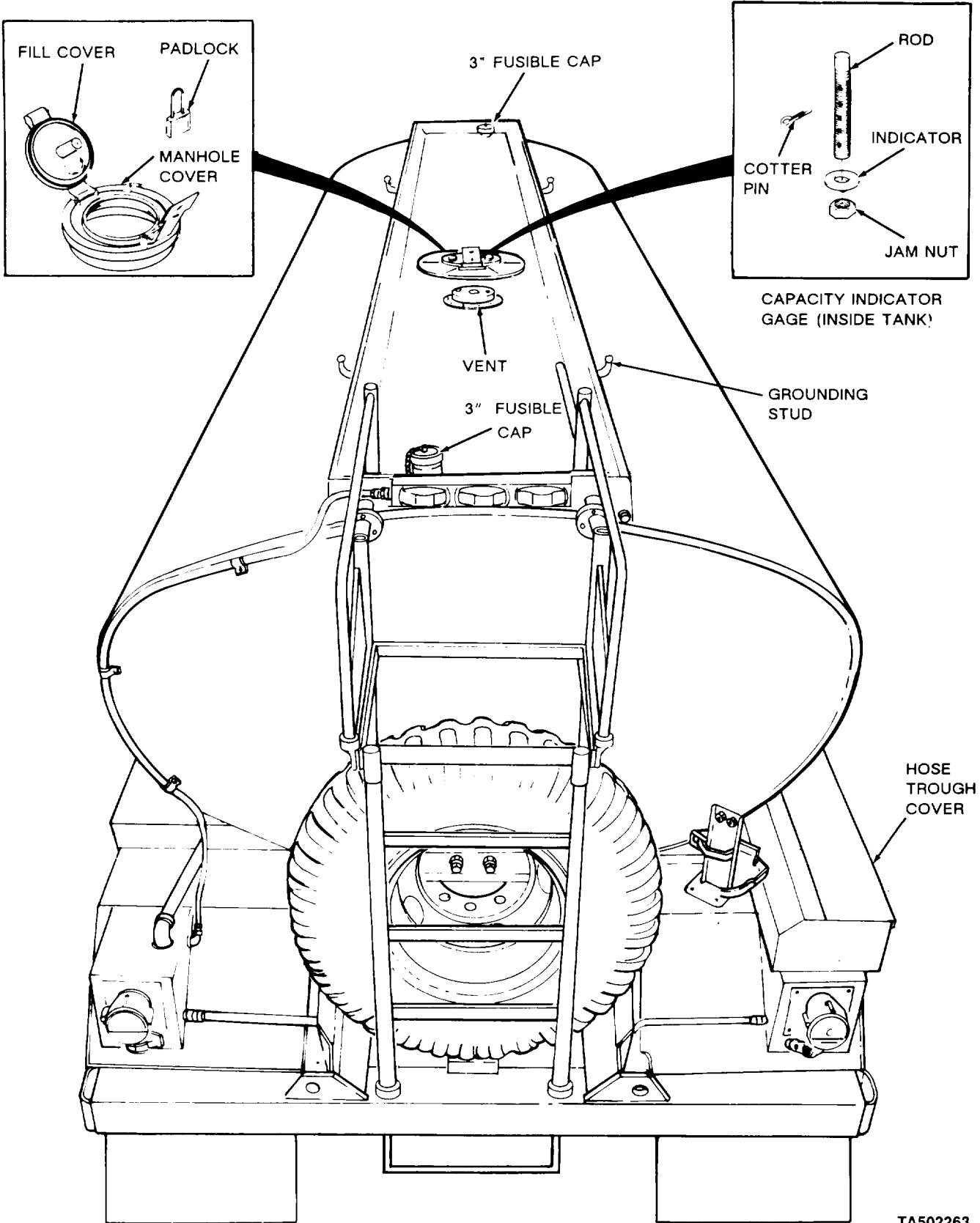

Figure 2-20. Typical Top View of Semitrailer.

TA502263

(b) *Loading With a Hose.* The loading hose from the storage facility may have a metal fitting on the free end, and the hose may not be bonded internally. Such a fitting is insulated and could become charged. Before opening fill cover, connect the vehicle bonding and grounding cable to grounding stud (fig. 2-7) on top of tank and to some part of the permanent piping of the loading facility.

(4) Remove fire extinguishers and bring them to the point of operation.

(5) Remove padlock. Slowly open fill cover (fig. 2-20) and insert hose far enough to keep end of hose in contact with bottom of tank.

**NOTE**

**The capacity indicator gage is located inside the tank near the fill cover (fig. 2-20).**

(6) Slowly begin flow, and fill tank no further than to the bottom of the capacity indicator.

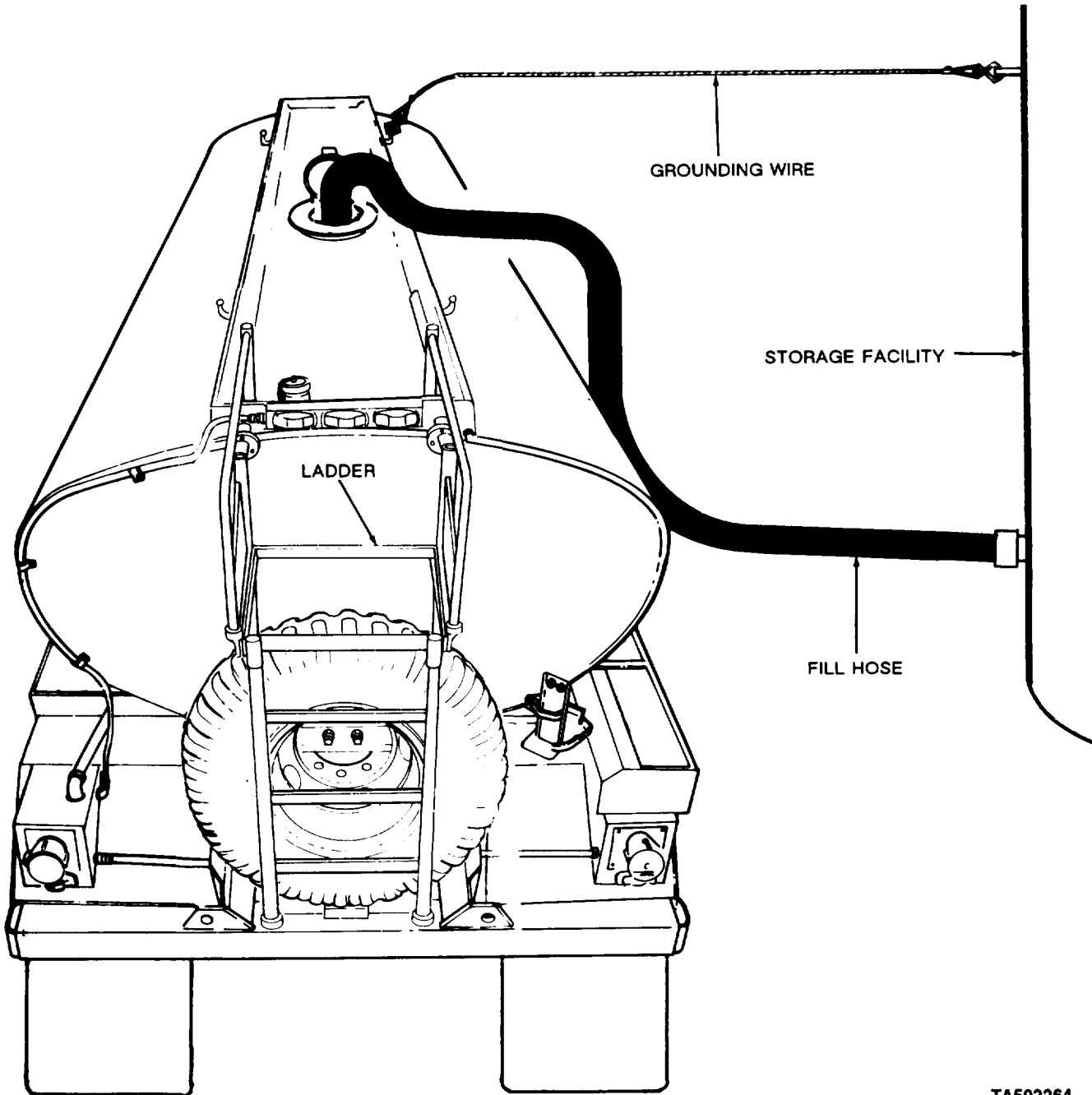

Figure 2-21. Typical Arrangement for Top Loading.

TA502264

- (7) Capacity indicator may be adjusted as follows:
- (a) Locate the semitrailer on level ground.
  - (b) Ensure that tank is empty.
  - (c) Fill the tank by metering in 5000 gallons of fuel.
  - (d) Loosen the jam nut and screw the round level indicator up or down, as required, until the fuel level just touches the bottom of the indicator. Hold indicator firmly and tighten the jam nut. No further adjustment should be required.
- (8) Remove fill hose. Close and secure manhole fill cover. Install padlock.

- (9) Drain accumulated water (para 2-13d).
- (10) Remove grounding clip from grounding stud on top of tank. Store and cover fire extinguishers.
- b. *Bottom Loading (Nonfiltered) (Fig. 2-22).*
- (1) Review instructions in paragraph 2-8.
  - (2) Ensure that all valves are closed.
  - (3) Ground the semitrailer tank (para 2-8).
  - (4) Remove cover from bottom loading connection. Connect bottom loading hose to bottom loading connection (fig. 2-22 and 2-11 or 2-12). Have fire extinguishers ready.

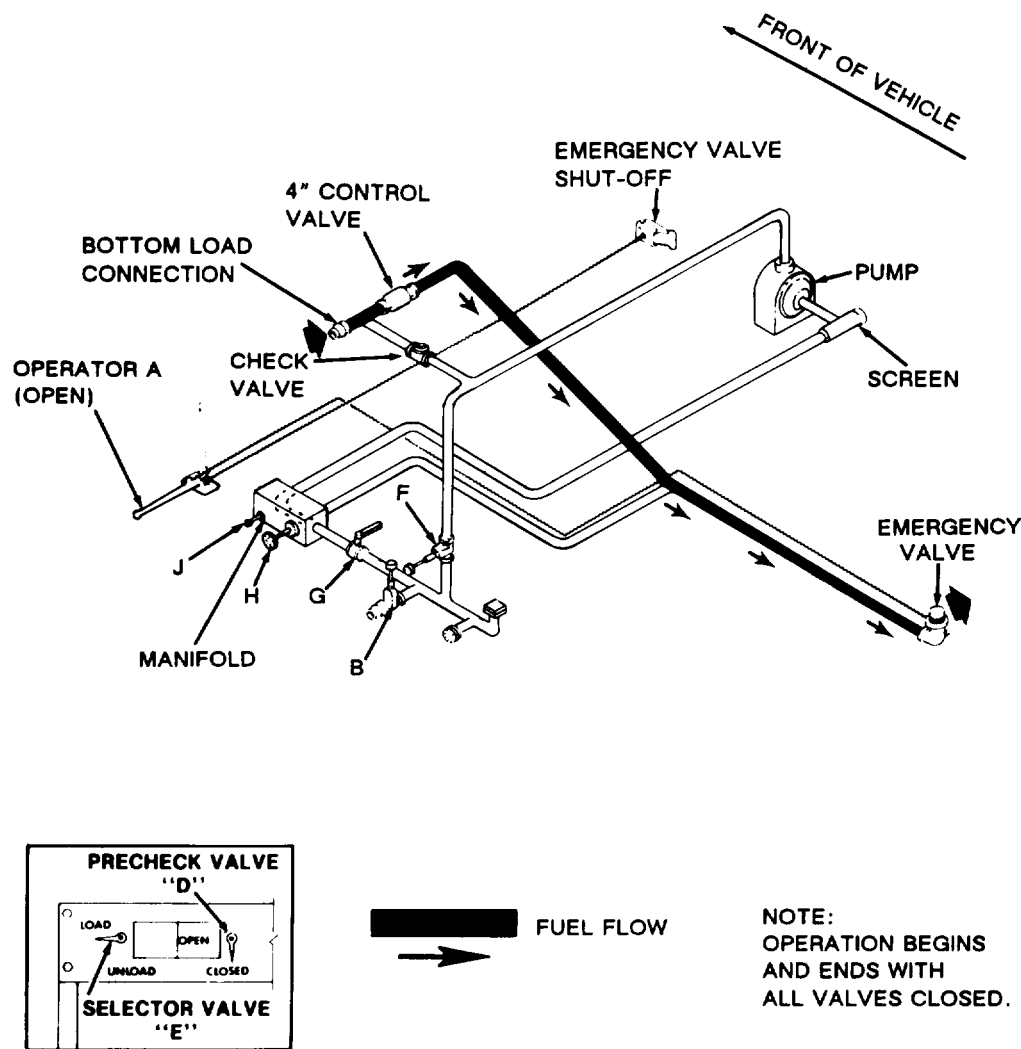

Figure 2-22. Typical Bottom Loading Flow Diagram for All Models (M967 and M967A1 Arrangement Shown). TA502265

(5) Put selector valve E (fig. 2-11) in LOAD position (M967, M967A1, M969, and M969A1).

(6) Open emergency valve operator A (fig. 2-11 or 2-12) (para 2-11f).

(7) Begin flow.

**WARNING**

**When filling tank by means of bottom loading, a test of the precheck system is mandatory. If this system is not functioning, stop all operations. Determine the problem and have it corrected by a qualified technician. Failure of automatic shut-off to function may result in uncontrolled fuel spillage and danger of fire and explosion.**

(8) After flow has begun, open valve D to precheck the shut-off float (para 2-11g). If float is functional, flow should stop after about 20-25 seconds.

(9) Close valve D. Flow will resume in about 20 seconds.

**NOTE**

**Be prepared to stop the fuel supply at the loading facility in event of shut-off float malfunction, if leaks are apparent, or other unusual conditions are seen.**

(10) When tank is full, the flow should stop automatically. Close all valves, replace all covers, and disconnect the hoses.

(11) Drain accumulated water (para 2-13d).

(12) Remove grounding wires.

(13) Store and cover fire extinguishers.

c. *Gravity Unload.*

(1) Review instructions in paragraph 2-8.

(2) Ensure that all valves are closed.

(3) Connect grounding wire to storage facility and grounding stud (fig. 2-7) on top of semitrailer.

(4) Remove 4-inch bulk delivery hose(s) from trough (fig. 2-20) by disconnecting spring pins and turning hose trough bars out of the way.

(5) Remove dust cover from outlet B (figs. 2-23 and 2-11 or 2-12), and connect hose to outlet B and to storage facility.

(6) Remove fire extinguishers and bring to point of operation.

(7) Make sure valve E (fig. 2-11) (M967, M967A1, M969, and M969A1) is in the UNLOAD position.

(8) Open valves A (para 2-11f), H, G, and B (fig. 2-11 or 2-12) to begin flow.

(9) At end of operation, close all valves. Disconnect the hose and put it in hose trough; secure hose trough latches. Reinstall dust cover on outlet B.

(10) Drain accumulated water (para 2-13d).

(11) Remove grounding wires.

(12) Store and cover fire extinguishers.

d. *Water Drain.* Accumulated water should be drained from the system after each period of operation (fig. 2-24).

(1) Ensure that all valves are closed.

(2) Put a container under manifold drain in piping control cabinet. Open emergency valve operator A. Slowly open valves H and J. Allow to drain until pure fuel begins to flow. Close valves H and J, and emergency valve operator A.

(3) Drain the pilot lines on all models. Open drain valves as indicated in figure 2-25. Allow to drain until fuel begins to flow. Close drain valves.

(4) On models M969, M969A1, M970, and M970A1, also drain the filter/separator. Open valve M. Put a container under valve N on bottom of filter/separator. Slowly open valve N. Allow to drain until fuel begins to flow. Close valves N and M.

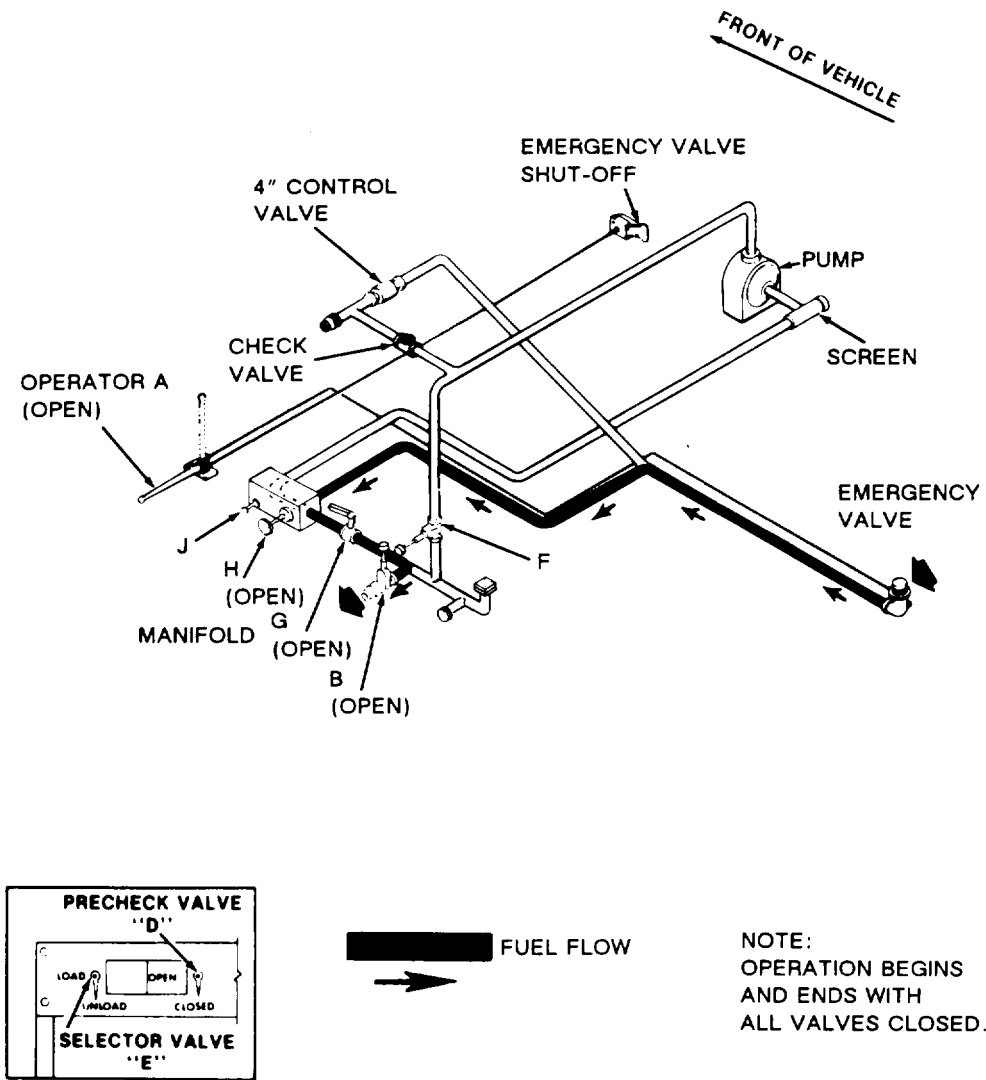

TA502266

Figure 2-23. Typical Gravity Unload Flow Diagram for All Models (M967 and M967A1 Arrangement Shown).

NOTE:  
OPERATION BEGINS  
AND ENDS WITH  
ALL VALVES CLOSED.

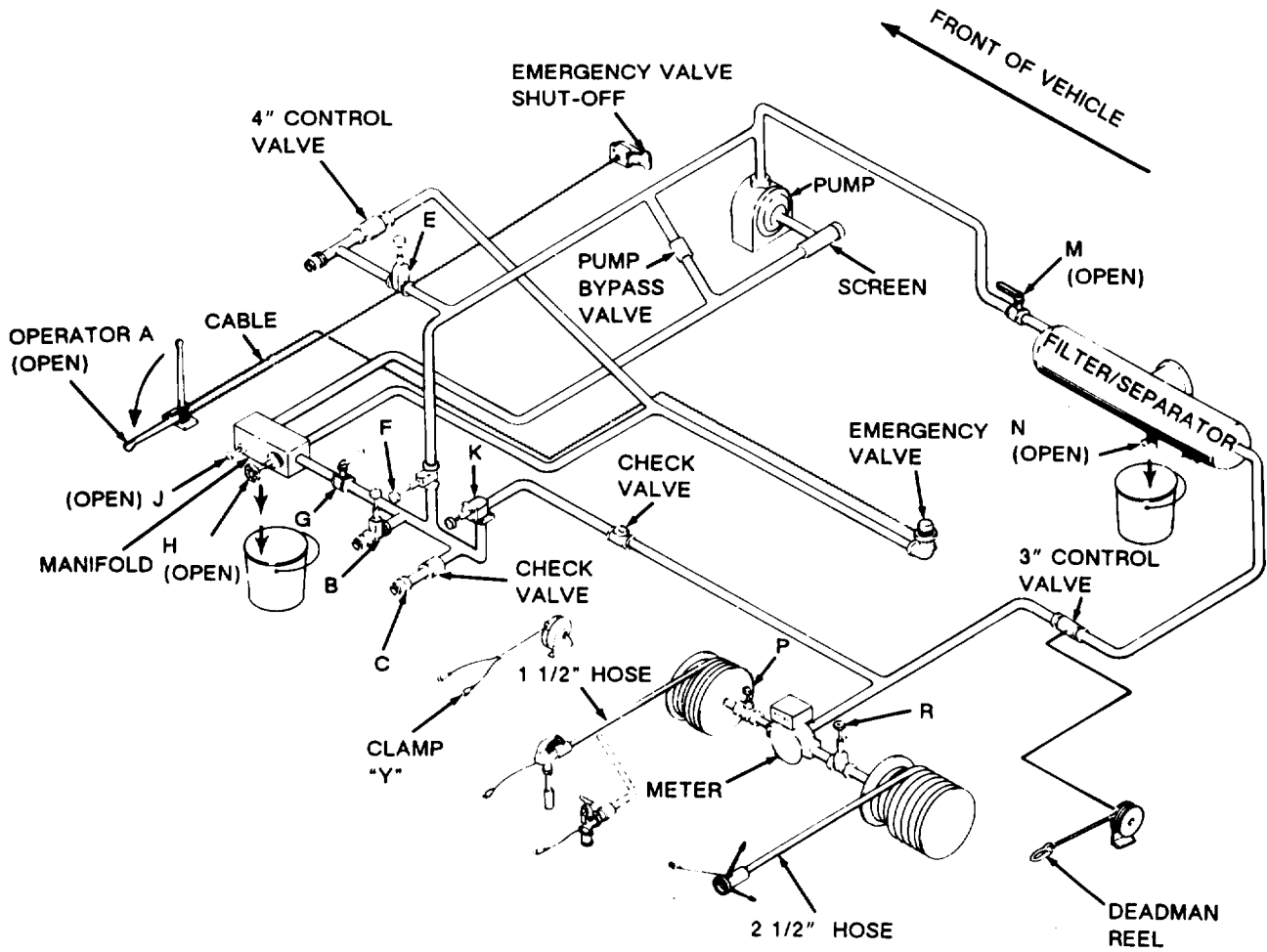
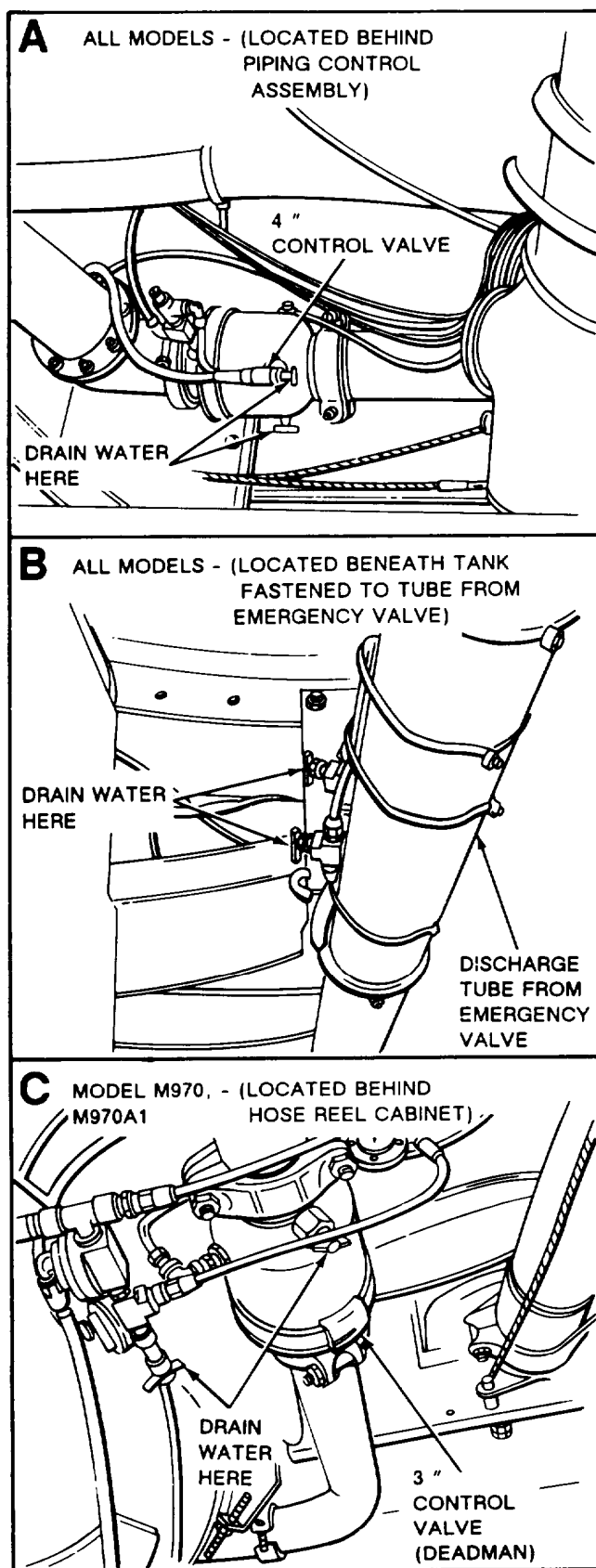

Figure 2-24. Typical Water Drain for All Models (M970 and M970A1 Arrangement Shown).

TA502283





TA221176

Figure 2-25. Pilot Line Water Drains.

## 2-14. Nonfiltered Fuel Servicing involving Use of Engine and Pump

a. *Self-Load (M967, M967A1, M969, and M969A1).* Use the following procedure when it is necessary to use the onboard engine and pump to load fuel from the storage facility to the semitrailer (fig. 2-26).

- (1) Review instructions in paragraph 2-8.
- (2) Ensure that all valves are closed.
- (3) Connect static reel to storage facility (fig. 2-7). Remove fire extinguishers and bring to point of operation.
- (4) Start engine (para 2-10). When engine is warm, adjust to idle speed (1000-1200 rpm).
- (5) Remove 4-inch bulk fuel hose from hose trough (para 2-13).
- (6) Remove dust cover from outlet B and connect bulk fuel hose to outlet and storage facility.
- (7) Put valve E (fig. 2-11) in LOAD position.
- (8) Open valves A (para 2-11), B, and G.
- (9) Adjust engine throttle for desired flow rate (table 2-2).

### WARNING

**When filling tank by means of bottom loading, a test of the precheck system is mandatory. If this system is not functioning, stop all operations. Determine the problem and have it corrected by a qualified technician. Failure of automatic shut-off to function may result in uncontrolled fuel spillage and danger of fire and explosion.**

(10) Shortly after flow has started, open valve D to precheck the shut-off float. If float is functional, flow should stop after about 20-25 seconds (para 2-11g).

(11) Close valve D. Flow will resume in about 20 seconds.

### WARNING

**In an emergency, close valve A or pull emergency valve shut-off on opposite side of semitrailer.**

(12) When tank is full, flow should stop automatically.

(13) At end of operation, idle down engine. Close all valves. Disconnect 4-inch bulk fuel hose(s) and put them in hose trough. Secure hose trough latches.

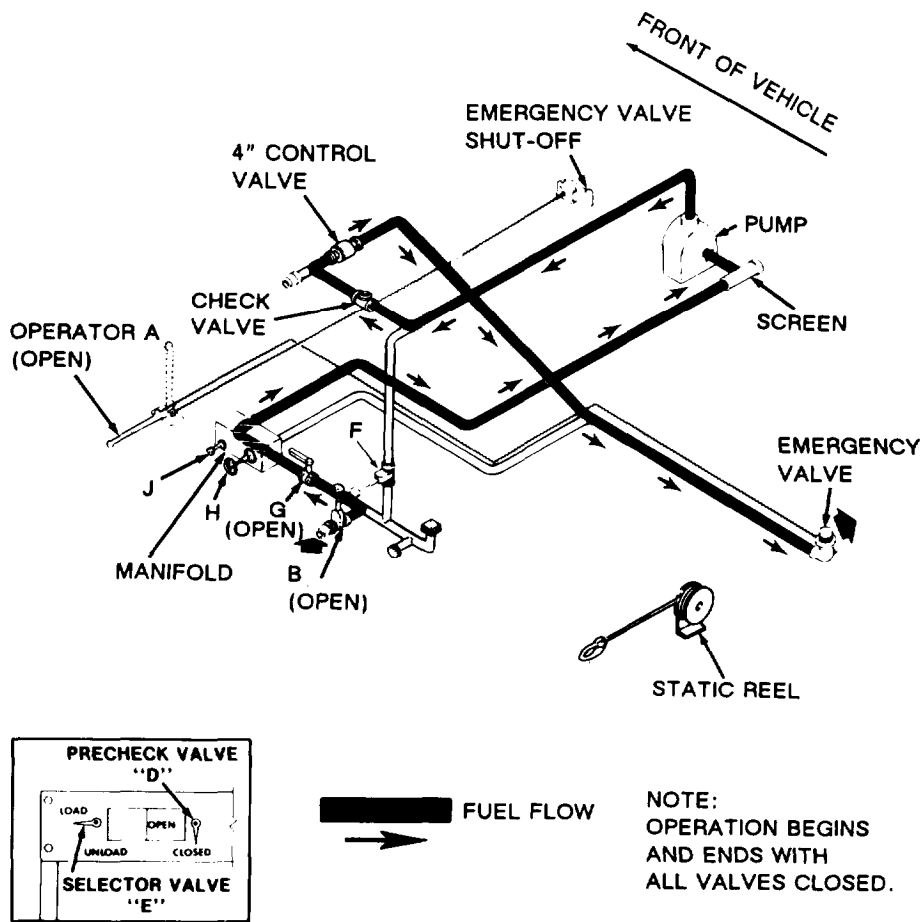

TA502267

Figure 2-26. Self-Load Flow Diagram (M967, M967A1, M969, M969A1) (M967 and M967A1 Arrangement Shown).

Table 2-2. Fuel Dispensing Flow Rates in Gallons Per Minute (GPM).

**M967 and M967A1 -BULK**

SELF-LOAD			BULK DELIVERY	
ENGINE rpm	2200	2400	2200	2400
PUMP GPM	290	320	480	530

**M969 and M969A1 -AUTOMOTIVE**

SELF-LOAD			DISPENSING				BULK DELIVERY			
			FILTERED		NONFILTERED		FILTERED		NONFILTERED	
ENGINE rpm	2200	2400	1200	2400	2200	2400	2200	2400		
PUMP GPM	290	320	44	88	44	88	175	190	480	530

**M970 and M970A1 -AIRCRAFT UNDERWING/OVERWING**

SELF-LOAD FILTERED			OVERWING REFUELING		UNDERWING REFUELING		DEFUEL FILTERED	
ENGINE rpm	2200	2400	2200	2400	2200	2400	2200	2400
PUMP GPM	220	240	90	100	220	240	50	60

- (14) Stop engine (para 2-10d).
  - (15) Drain accumulated water (para 2-13d).
  - (16) Remove grounding wires.
  - (17) Store and cover fire extinguishers.
- b. *Bulk Delivery (All Models).* To pump fuel from the semitrailer to the storage facility (fig. 2-27), use the following procedure:
- (1) Review instructions in paragraph 2-8.
  - (2) Ensure that all valves are closed.
  - (3) Connect grounding wire to storage facility and grounding stud on top of semitrailer (fig. 2-7). Remove fire extinguishers and bring them to the point of operation.
  - (4) Start engine (para 2-10). When engine is warm, adjust throttle to idle speed (1000-1200 rpm).
  - (5) Remove 4-inch bulk fuel hose from trough (para 2-13c).

- (6) Remove dust cover from outlet B (fig. 2-11 or 2-12), and connect fuel hose to outlet and storage facility.
- (7) Put valve E in UNLOAD position (M967, M967A1, M969, and M969A1).
- (8) Ensure that valve E is in closed position on M970 and M970A1.
- (9) Open valves A (para 2-11f), B, F, and H.
- (10) Adjust engine throttle for desired flow rate (table 2-2).
- (11) Idle down engine at end of operation. Close all valves, disconnect hose (s), and reinstall dust cover.
- (12) Put bulk fuel hoses in hose trough and secure latches.
- (13) Stop engine (para 2-10d).
- (14) Drain accumulated water (para 2-13d).
- (15) Remove grounding wire.
- (16) Store and cover fire extinguishers.

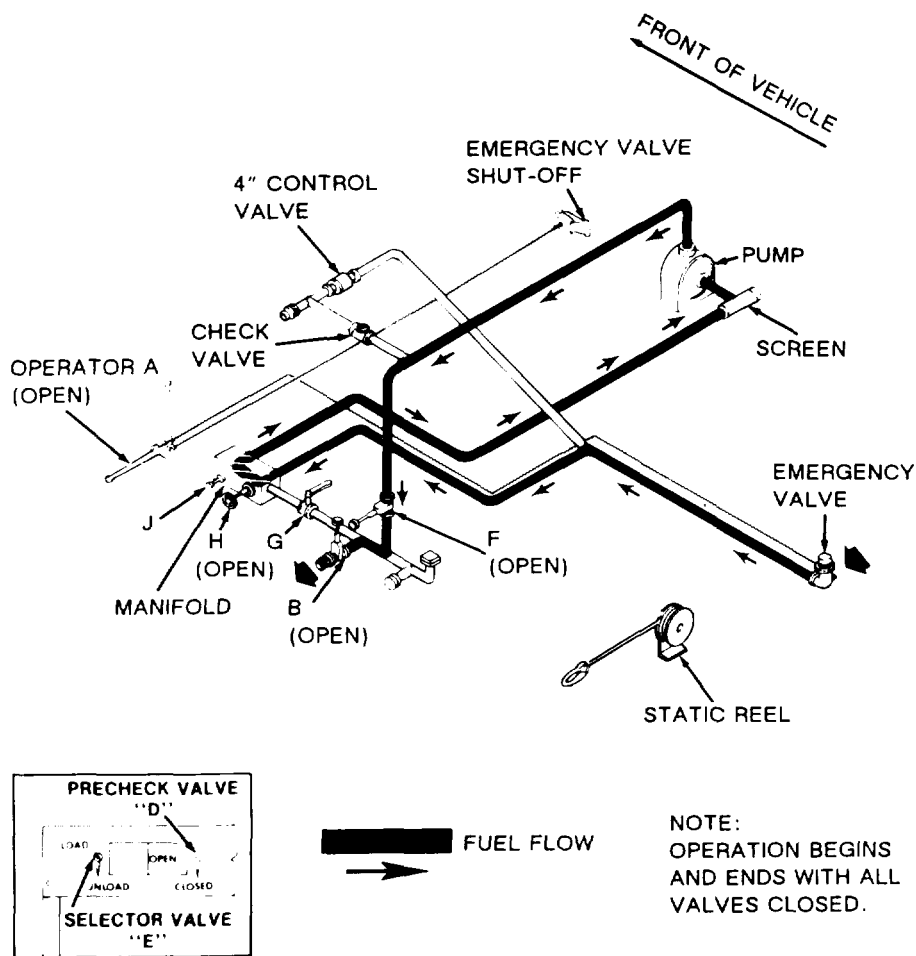

Figure 2-27. Typical Bulk Delivery Flow Diagram (M967 and M967A1 Arrangement Shown).

TA502268

c. *Nonfiltered Dispensing (M969 and M969A1).* Fuel which does not require filtering is routed directly from the pump to the hose reels, bypassing the filter/separator (fig. 2-28). Use the following procedure:

- (1) Review instructions in paragraph 2-8.
- (2) Ensure that all valves are closed.

**NOTE**

**If two vehicles are being serviced, make sure they are both grounded using separate static reels. M969 and M969A1 are equipped with two static reels (figs. 2-11 and 2-14).**

(3) Unreel static reel cable (fig. 2-11), and connect it to a suitable ground and to automotive

unit /container. Remove fire extinguishers and bring them to the point of operation.

- (4) Start engine (para 2-10c). When engine, is warm, adjust throttle to idle speed (1000-1200 rpm).
- (5) Put valve E (fig. 2-11) in UNLOAD position.
- (6) Open valves A (para 2-11f), F, H, and K.
- (7) Reset meter (fig. 2-14) to zero by pushing reset knob and turning clockwise. Open either valve P or R.
- (8) Adjust engine throttle for desired flow rate (table 2-2).

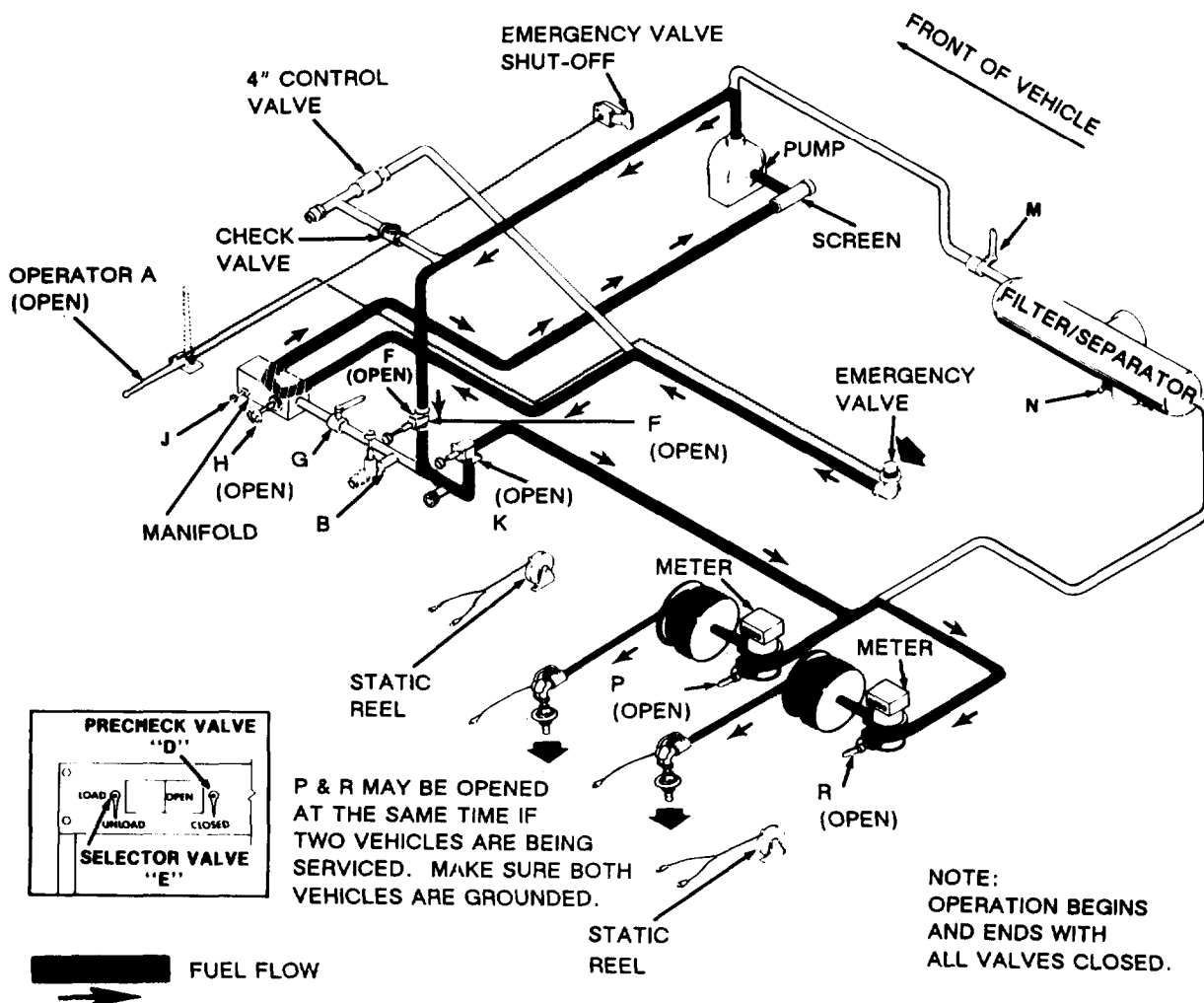

Figure 2-28. M969 and M969A1, Nonfiltered Dispensing Flow Diagram.

TA502269

(9) Release lock on hose reel (para 2-11) and unreel hose.

(10) Insert nozzle into vehicle fuel tank/container. Squeeze nozzle trigger to start flow.

(11) At end of operation, release nozzle trigger and remove nozzle from vehicle fuel tank/container.

(12) Idle down engine to 1000-1200 rpm.

(13) Rewind the hose(s) (para 2-11). Tighten hose reel lock(s).

(14) Close all valves.

(15) Stop engine (para 2-10d).

(16) Disconnect and rewind the static ground wire.

(17) Store and cover fire extinguishers.

d. *Hose Evacuation (M970 and M970A1).* To purge or remove fuel from the dispensing system, use the following procedure. This procedure must be done after every operation using the dispensing hoses (fig. 2-29).

(1) Review instructions in paragraph 2-8.

(2) Ensure that all valves are closed.

(3) Remove fire extinguishers and bring to point of operation.

(4) Start engine (para 2-10). When engine is warm, adjust to idle speed (1000-1200 rpm).

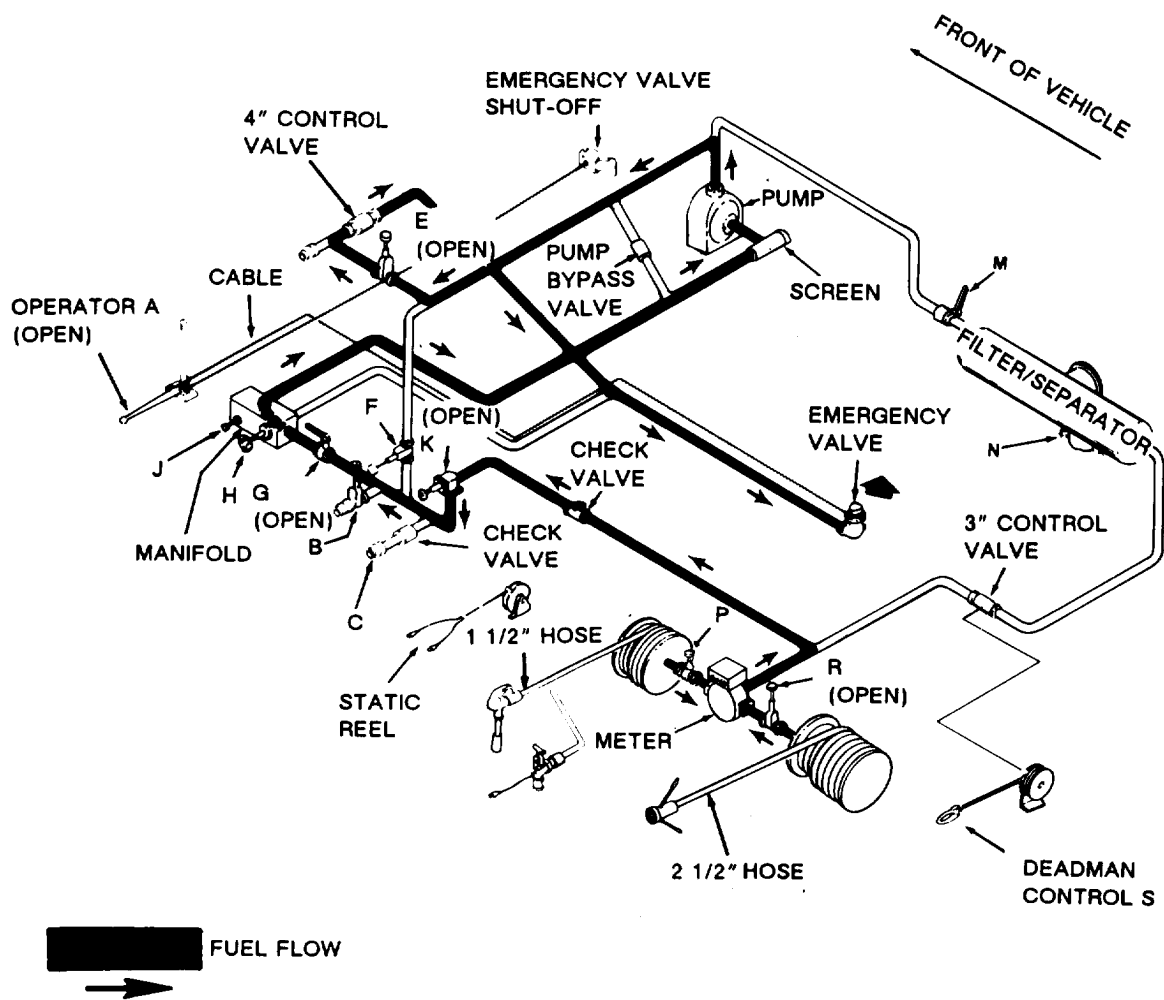

NOTE:  
OPERATION BEGINS  
AND ENDS WITH  
ALL VALVES CLOSED.

TA502270

Figure 2-29. Hose Evacuation Flow Diagram (M970 and M970A1).

(5) Open valves A (para 2-11f), E, G, and K (fig. 2-29). Open valve P to evacuate the 1½-inch hose and/or valve R to evacuate the 2½-inch hose.

(6) Set engine throttle to maximum speed (2400 rpm) for a few seconds until evacuation is completed (meter stops turning backward).

(7) Idle down engine. Close all valves. Stop engine (para 2-10d).

(8) Store and cover fire extinguishers.

**2-15. Filter/Separator Operation (M969, M969A1, M970, and M970A1)**

*a. General.*

(1) *Filtering Process (Fig. 2-30).* With the addition of the filter/separator on the M969, M969A1, M970, and M970A1, the engine and pump assembly provides filtered fuel for various servicing operations. The filter/separator consists of an aluminum tank with 15 filter elements and 5 second-stage water stripper elements. Fuel under pressure from the pump enters the filter case inlet and flows through the 15 filter elements, where solid particles

are removed. The fuel then flows through the second-stage filter elements, which further filters minute particles and coalesces water particles to be collected in the filter sump. Coalescence is a process by which many small droplets of free water in the fuel are collected to form larger water drops. These large water drops are then released into the filter sump.

(2) *Automatic Water Drain.* When water in the filter sump reaches a certain level, the water is automatically ejected out of the filter sump. This is accomplished by an automatic drain valve connected to the filter sump. The drain valve has a ball float which will float in water but not in any type of fuel. Automatic water drain for the M969 and M969A1 is different than for the M970 and M970A1.

(a) As water accumulates in the filter sump of the M969 and M969A1, a float rises. When the float rises to a certain level, a valve will open in the automatic drain valve, allowing pump pressure to be applied to a diaphragm valve opening the automatic drain valve. Water is then ejected out of the filter sump through the automatic drain valve. As water is being ejected, fuel flow is continued.

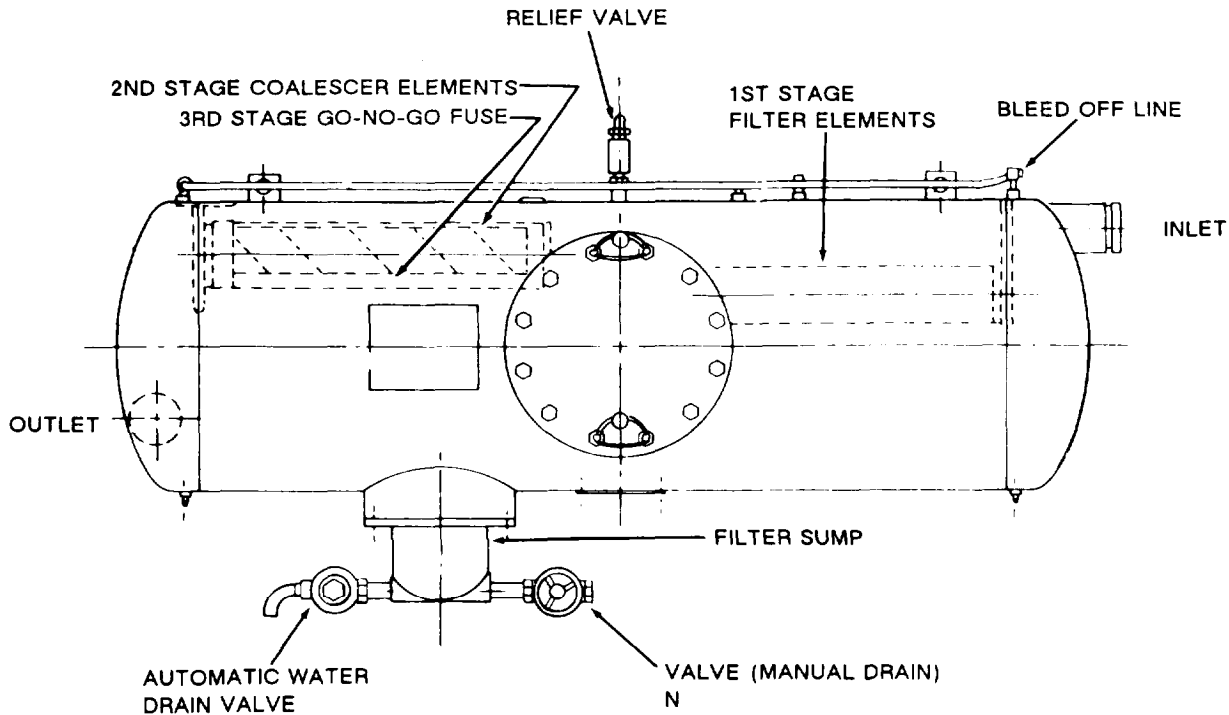

**Figure 2-30. Filter/Separator Assembly (M969, M969A1, M970, and M970A1).**

TA502271

(b) As water accumulates in the filter sump of the M970 and M970A1, a float rises. When the float rises a certain level, a valve will open in the automatic drain valve, allowing pump pressure to be applied to a diaphragm valve in the automatic drain valve and to the pilot control on the 3-inch flow control valve. The pump pressure opens the diaphragm valve and closes the 3-inch flow control valve. Fuel flow is then shut off, preventing dispensing of water-contaminated fuel, and the water in the filter sump is passed through the automatic drain valve. When the fuel flow is stopped by the closing of the 3-inch flow control valve, no coalescing occurs, and the automatic water drain valve will continue passing water until the float lowers. With the float in the lowered position, the water drain valve closes, and the 3-inch control valve opens. When this happens, pressure is trapped in the line to the automatic drain valve diaphragm and pilot control of the 3-inch control valve, preventing resumption of fuel flow. To release the pressure, a bleed line from the automatic drain valve diaphragm and pilot control will relieve the pressure at the discharge side of the water drain valve. Fuel flow will automatically start again.

(3) *Cold Weather Draining.* During cold weather operations, the accumulated water in the sump may freeze. It is important that the manual drain N (fig. 2-30) on the sump be opened after each operation to drain the water accumulation. Be sure to close the drain valve after draining.

(4) *Go-No-Go Fuses.* Each of the 5 second-stage coalescing elements is equipped with three Go-No-Go fuses. These fuses are fuel contaminant monitoring devices located “down-stream” of the second-stage. The fuses restrict the fuel flow when small amounts of water and solid contaminants are present in the fuel stream.

(a) Each fuse consists of a perforated metal tube filled with thin cellulose washers, except for a space about 1-inch long at one end. This space is for a plastic piston forced against the washers by a spring. A plastic nipple at the other end of the metal tube fits into an outlet socket in the housing. Fuel flow is through the spirally arranged perforations in the metal tube. The fuel must flow through the very small passages (about 5 microns) between the cellulose washers to reach the outlet.

(b) As solid contaminants accumulate on the outer surface of the stack of washers, resistance to fuel flow increases. The resulting increased pressure further compresses the washer stack. When the contaminant is water, it is also absorbed by the cellulose washers, and the action of the filter is similar.

(c) When solid contaminants or water are present, the compression of the washer stack continues until fuel flow is stopped completely. But until this

happens, whatever fuel is passed through is still within the specified standards for purity.

b. *Filter/Separator Gage.* The filter elements have a limited capacity for retaining solids. As the solids content increases, a pressure drop across the elements increases. The pressure drop can be measured by a pressure gage provided in the instrument panel (fig. 2-9). Operating pressure readings should be taken and recorded at the first day of operation and each day of operation thereafter. At initial operation or with replacement elements, the pressure gage reading should not exceed 3 psi. When the pressure gage reading reaches 25 psi, the elements are dirty and should be replaced. Notify unit maintenance personnel when pressure reaches 25 psi.

## 2-16. Filtered Fuel Servicing Operations (M969 and M969A1)

a. *Filtered Bulk Delivery.* This operation is to be used when filtered fuel is required in the storage facility (fig. 2-31). Fuel is pumped from the semitrailer tank through the filter/separator to the storage facility. Filtered bulk delivery operation is as follows:

- (1) Review instructions in paragraph 2-8.
- (2) Ensure that all valves are closed.
- (3) Connect grounding wire to storage facility and semitrailer (fig. 2-7). Remove 4-inch bulk fuel hose (para 2-13) from hose trough and connect it to the receiving facility. Remove dust cap from outlet B and connect bulk fuel hose to outlet.
- (4) Remove fire extinguishers and bring them to the point of operation.
- (5) Start engine (para 2-10) and when warm adjust engine speed to 1000-1200 rpm.
- (6) Put selector valve E in UNLOAD position.
- (7) Open valves A (para 2-11f), B, H, M, and K.
- (8) Adjust engine throttle for desired flow rate (table 2-2).
- (9) At end of operation, adjust engine to idle speed (1000-1200 rpm).
- (10) Close all valves.
- (11) Remove all hoses and store in hose troughs. Secure hose trough latches. Reinstall dust cover on outlet B.
- (12) Shut off engine (para 2-10d).
- (13) Remove grounding wire.
- (14) Cover and store fire extinguishers.

NOTE:  
OPERATION BEGINS  
AND ENDS WITH  
ALL VALVES CLOSED.

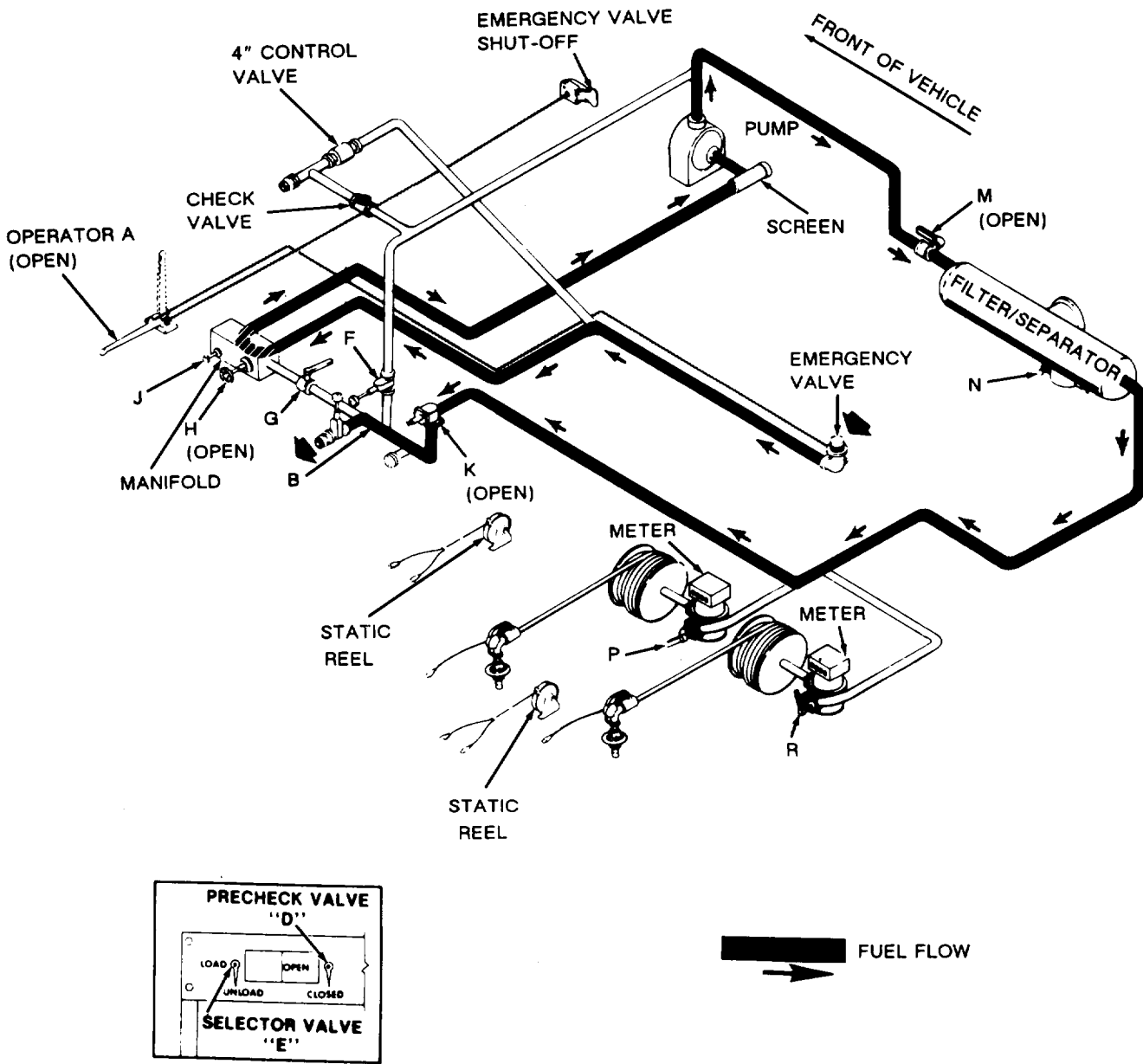

Figure 2-31. Filtered Bulk Delivery Flow Diagram (M969 and M969A1),

TA502272



b. *Filtered Fuel Dispensing.* This operation is used to dispense metered fuel from the semitrailer tank to a vehicle. Fuel is pumped through the filter/separator, a meter, and a hose reel to the vehicle (fig. 2-32). Operation is as follows:

- (1) Review instructions in paragraph 2-8.
- (2) Ensure that all valves are closed.
- (3) Unreel the static reel and connect cable first to grounding stud, then to vehicle.
- (4) Remove fire extinguishers and bring to point of operation.

(5) Start engine (para 2-10) and when warm adjust engine speed to 1000-1200 rpm.

(6) Put selector valve E (fig. 2-11) in the UNLOAD position.

(7) Open valves A (para 2-11f), H, M, and either P or R, depending on which hose reel is to be used. If both hose reels are to be used, open both valves P and R. Reset meter to zero by pushing in the meter reset knob (fig. 2-14) and turning clockwise.

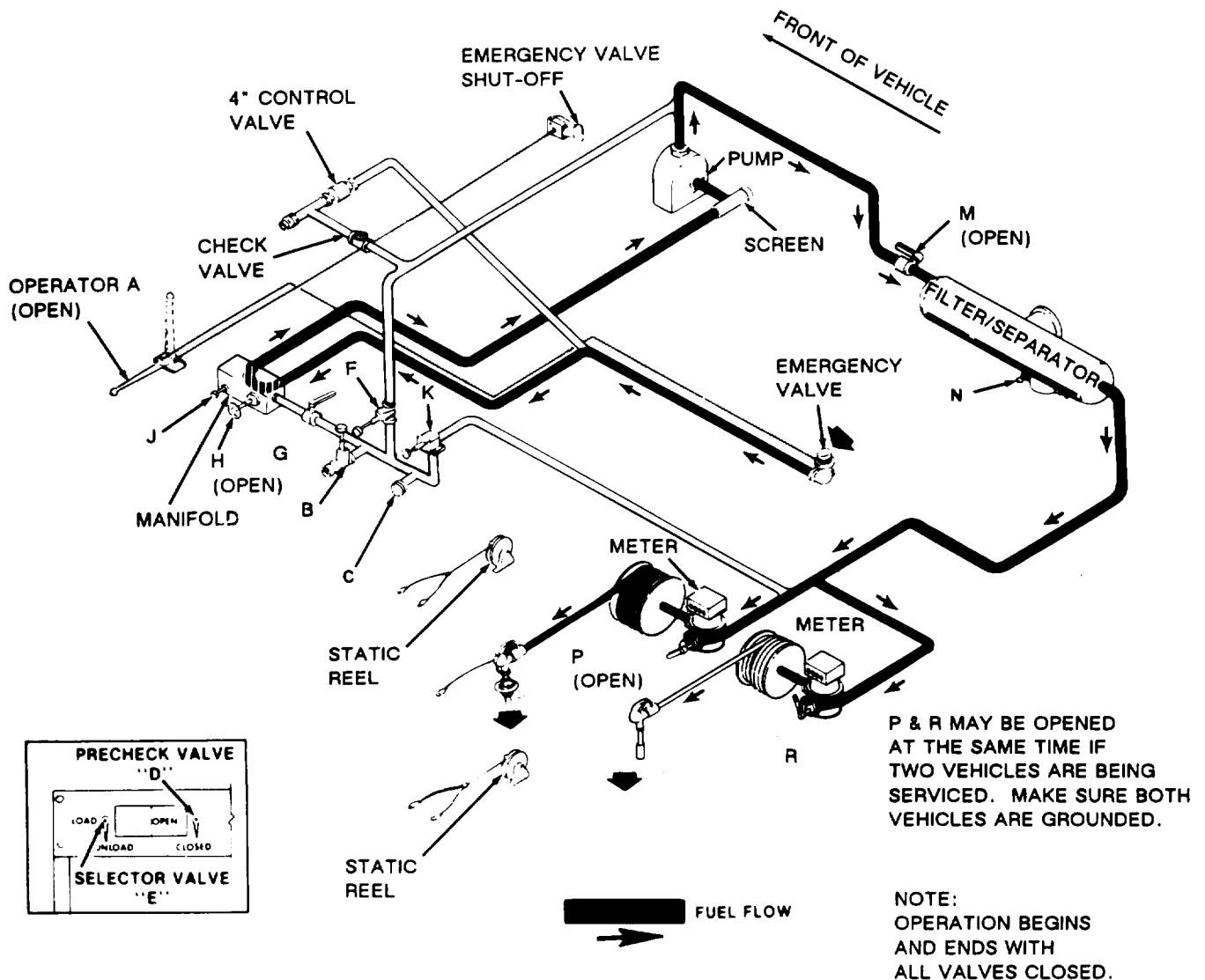

Figure 2-32. Filtered Fuel Dispensing Flow Diagram (M969 and M969A1).

TA502273

(8) Adjust engine throttle for desired flow rate (table 2-2).

(9) Release lock (para 2-11) on hose reel(s) to be used. Unreel hose(s) completely.

(10) Insert nozzle into vehicle being serviced, and squeeze nozzle trigger to start flow.

(11) Release nozzle trigger at end of operation and remove nozzle from vehicle.

(12) Adjust engine to idle speed (1000-1200 rpm).

(13) Rewind hose(s) (para 2-11). Do not rewind both hose reels at the same time. Tighten hose reel lock.

(14) Close all valves.

(15) Shut off engine (para 2-10d).

**WARNING**

**DO NOT let go of the static reel cable when rewinding until the ball stop is firmly touching the reel. Failure to follow this warning may cause injury to personnel.**

(16) Disconnect static reel cable first from vehicle, then from ground. Rewind static reel cable.

(17) Cover and store fire extinguisher(s).

c. *Fuel Sampling.*

**NOTE**

**Additional Information on fuel sampling may be obtained from FM 10-68.**

(1) Fuel sampling is done during filtered fuel dispensing operations. Fuel is removed through an Aqua-Glo probe and adapter installed on outlet nipple of one or both meters (figure 2-14).

(2) Refer to paragraph 2-18 for general fuel sampling instructions.

**2-17. Filtered Fuel Servicing Operations (M970 and M970A1 )**

a. *Filtered Self-Load.* This operation is a means of loading filtered fuel through the bottom of the tank. Fuel is pumped from the storage facility through the filter/separator, meter, 2½-inch hose reel, and bottom load adapter (fig. 2-34). Filtered self-load operation is as follows:

(1) Review instructions in paragraph 2-8.

**WARNING**

**Hose reel cabinet door is heavy-use two hands when opening and closing. Use latches to lock door. Do not slam.**

(2) Open hose reel cabinet door (fig. 2-33). Pull release cable and lift door with both hands.

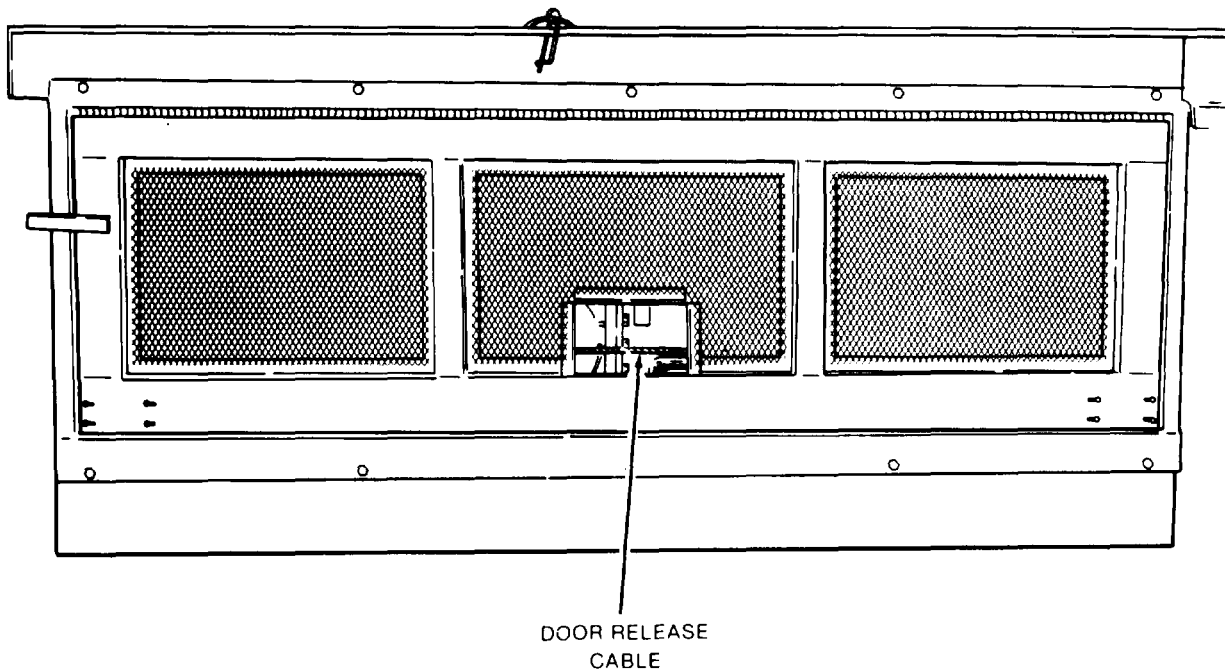

**Figure 2-33. Hose Reel Cabinet With Door Closed (M970 and M970A1).**

TA099715

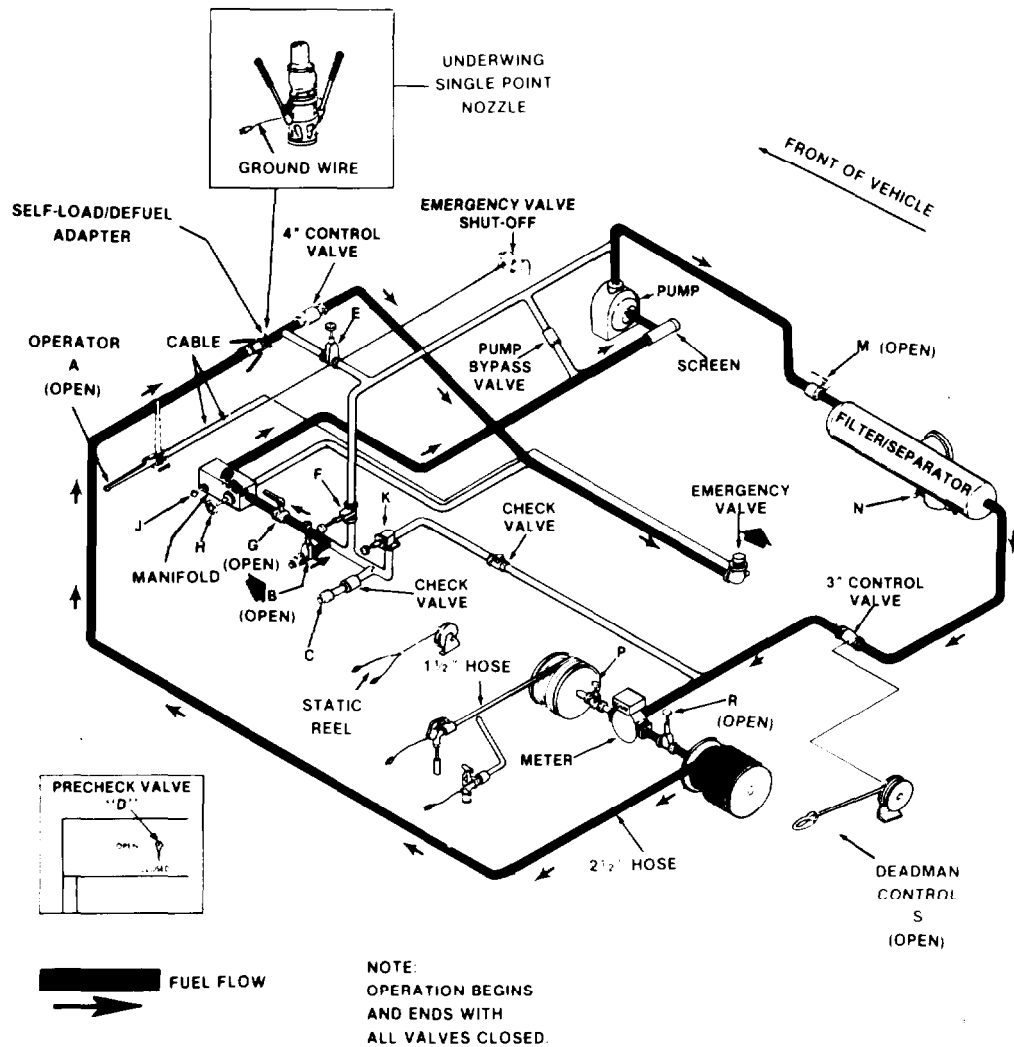

Figure 2-34. Filtered Self-Load Flow Diagram (M970 and M970A1).

TA502274

(3) Ensure that all valves are closed.

(4) Connect ground wire to storage facility and semitrailer (fig. 2-7). Remove 4-inch bulk fuel hose (para 2-13c) from hose trough and connect to storage facility. Remove dust cap from outlet B and connect bulk fuel hose to outlet.

(5) Remove fire extinguishers and bring to point of operation.

(6) Start engine (para 2-10) and when warm adjust engine speed to 1000–1200 rpm.

(7) Release lock (para 2-11c) on 2½-inch hose reel. Unreel 2½-inch hose fully. Remove dust cap from

bottom load adapter and connect underwing nozzle (fig. 2-34). Turn lever on side of nozzle to open the nozzle.

**NOTE**

**Make sure valve E is closed and remains closed during entire self-load operation.**

(8) Open valves A (para 2-11f), B, G, M, and R.

(9) Unreel deadman control S (para 2-11) and squeeze the lever. Meter inlet pressure gage (fig. 2-15) should read a minimum of 25 psi. Release the deadman control. Should gage not indicate a minimum of 25 psi, shut down operation and contact unit maintenance.

(10) Adjust engine throttle for desired flow rate (table 2-2).

**WARNING**

**When filling tank by means of self-loading, a test of the precheck system is mandatory. If this system is not functioning, stop all operations. Determine the problem and have it corrected by a qualified technician. Failure of automatic shut-off to function may result in uncontrolled fuel spillage and danger of fire and explosion.**

(11) Squeeze and hold lever on deadman control S. Shortly after flow has begun, turn precheck valve D to the OPEN position to check the automatic shut-off float. If float is functional, flow should stop after about 20-25 seconds (para 2-11g). If valve is not functioning, stop all operations. Notify unit maintenance.

(12) Turn precheck valve D to the CLOSED position. Free flow will resume in about 20 seconds.

**CAUTION**

**In an emergency, release the deadman control S and flow should stop.**

(13) When tank is full, flow should stop automatically.

(14) At end of operation, release the deadman control S, and adjust engine to idle speed (1000-1200 rpm). Rewind the deadman control hose.

(15) Close single point nozzle and disconnect nozzle from bottom load adapter. Reinstall dust caps on bottom load adapter and single point nozzle.

(16) Evacuate hose (para 2-14d).

(17) Rewind 2½-inch hose (para 2-11). Tighten hose reel lock.

(18) Close all valves and remove 4-inch bulk fuel hose connecting semitrailer to storage facility. Store hose in hose trough. Secure hose trough latches. Reinstall dust cap to outlet B.

(19) Shut off engine (para 2-10d), then remove the grounding wire.

**WARNING**

**Hose reel cabinet door is heavy-use two hands when opening and closing. Use latches to lock door. Do not slam.**

(20) Close hose reel cabinet door and latch in place,

(21) Store and cover fire extinguishers.

*b. Filtered Bulk Delivery.* This operation is used when filtered fuel is required in the storage facility (fig. 2-35). Fuel is pumped from the semitrailer tank through the filter/separator to the storage facility. Filtered bulk delivery operation is as follows:

(1) Review instructions in paragraph 2-8.

(2) Ensure that all valves are closed.

(3) Connect grounding wire to storage facility and semitrailer (fig. 2-7). Remove 4-inch bulk fuel hose from hose trough and connect to the receiving facility. Remove dust cap from outlet B and connect bulk fuel hose to outlet.

(4) Start engine (para 2-10) and when warm adjust engine speed to 1000-1200 rpm.

(5) Open valves A (para 2-11f), B, H, M, and K.

(6) Adjust engine throttle for desired flow rate (table 2-2).

(7) At end of operation, adjust engine to idle speed (1000-1200 rpm).

(8) Close all valves.

(9) Remove bulk fuel hose and store in hose troughs. Secure hose trough latches. Reinstall dust cap to outlet B. Remove grounding wire.

(10) Shut off engine (para 2-10d).

(11) Store and cover fire extinguishers.

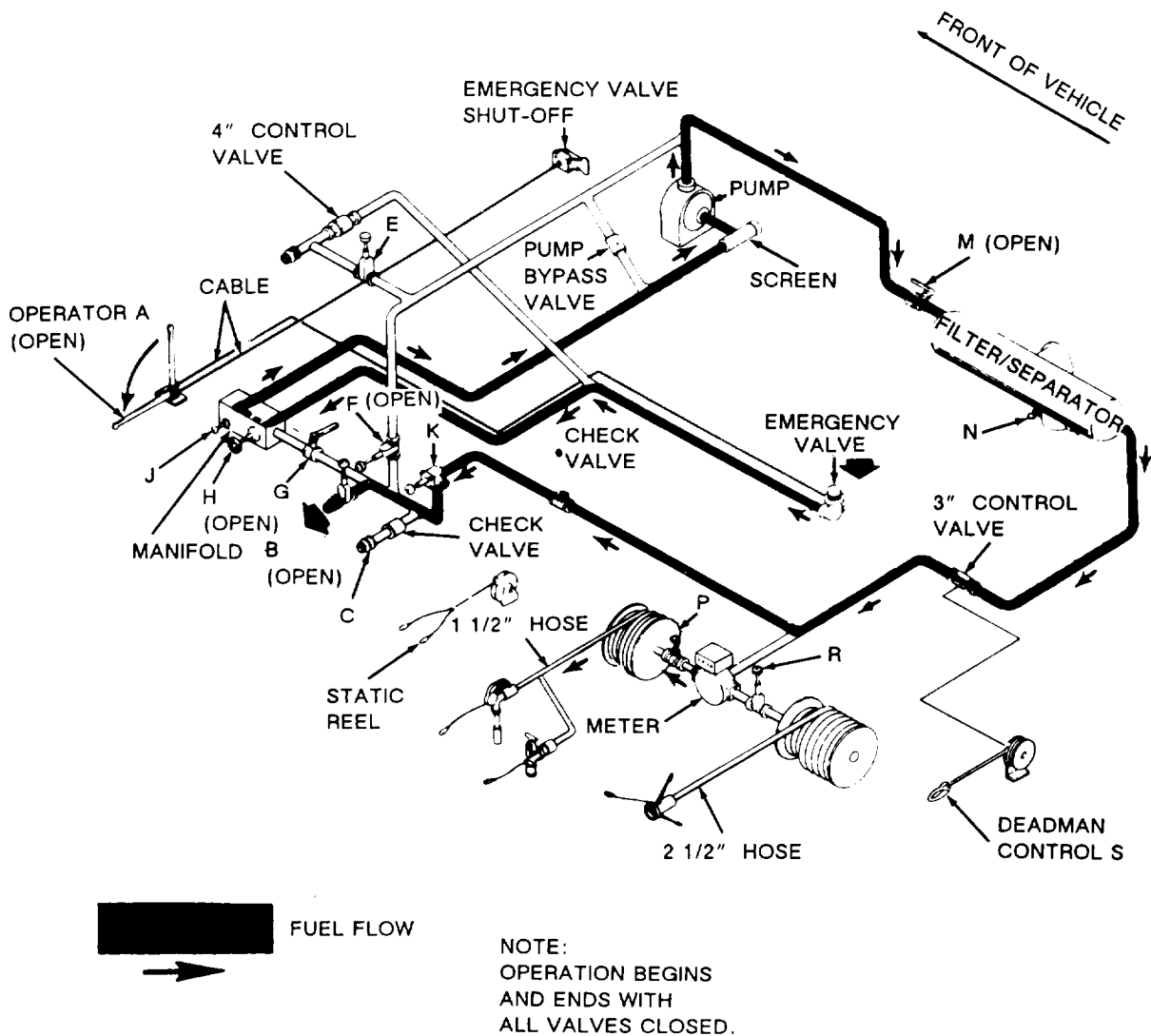

Figure 2-35. Filtered Bulk Delivery Flow Diagram (M970 and M970A1),

TA502275

2-18. Aircraft Fuel Servicing

NOTE

On the M969 and M969A1, an Aqua-Glo probe and adapter may be installed on outlet nipple of both or either meter for obtaining fuel samples for water content testing.

a. *Fuel Sampling.* Fuel sampling can be done during refueling aircraft and recirculating fuel operations. Fuel is removed through a fuel sampling adapter (fig. 2-36) in the single point nozzle or converter for overwing nozzle as follows:

(1) Remove fuel sampling adapter cap from single point nozzle or converter.

(2) Have fuel sampling container ready.

NOTE

Make sure fuel sampling hose is placed in container before attaching coupling to adapter. A valve in the adapter opens, allowing fuel to flow into container, when connector is screwed into coupling.

(3) Remove fuel sampling coupling from tool box and screw into adapter on single point nozzle or converter.

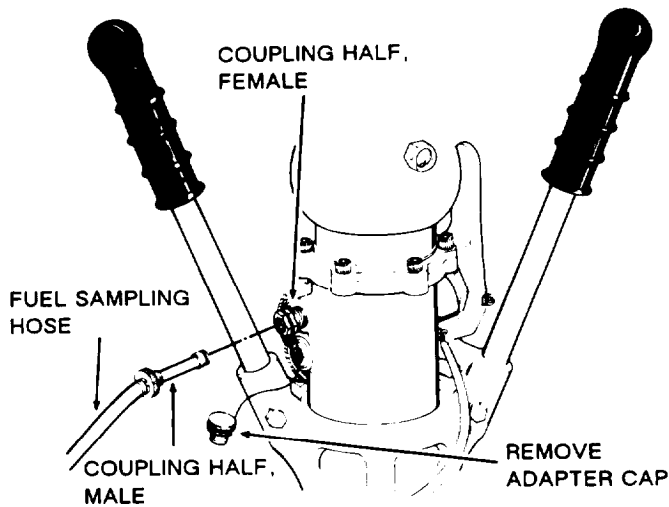

TA099718

**Figure 2-36. Attaching Fuel Sampling Hose to Nozzle (M970 and M970A1).**

(4) When enough fuel is collected, unscrew fuel sampling coupling from the adapter. Install cap on adapter and put fuel sampling coupling in tool box.

b. *Aircraft Single Point Underwing Fuel Dispensing Operation.* This operation is used to dispense metered fuel from semitrailer to an aircraft through an underwing connection. Fuel is pumped through the filter/separator, a meter, and a hose reel to the aircraft (fig. 2-37). Operation is as follows:

- (1) Review instructions in paragraph 2-8.

**WARNING**

**Hose reel cabinet door is heavy-use two hands when opening and closing. Use latches to lock door. Do not slam.**

- (2) Open hose reel cabinet door. Pull release cable and lift door with both hands.
- (3) Ensure that all valves are closed.
- (4) Unreel the static reel cable and connect it first to grounding stud and then to aircraft.
- (5) Remove fire extinguishers and take to point of operation.
- (6) Start engine (para 2-10) and when warm adjust engine speed to 1000-1200 rpm.

- (7) Open valves A (para 2-11f), H, M, and R. Reset the meter to zero by pushing the meter reset knob (fig. 2-15) and turning clockwise.

- (8) Adjust engine throttle for desired flow rate (table 2-2).

**NOTE**

**The breakaway fitting is a safety feature on hose reel for 2½-inch hose. It consists of a breakaway coupling installed between 2½-inch hose and outlet port of the hose reel. Should aircraft be moved with single point nozzle attached to wing, the coupling will break apart as hose is pulled tight against the coupling, preventing damage to the aircraft. For reassembly of breakaway fitting refer to paragraph 3-13.**

- (9) Release lock (para 2-11) on the 2½-inch hose reel. Unreel all 50-feet of 2½-inch hose to ensure that breakaway feature will be operable.

**WARNING**

**Bonding of the semitrailer to aircraft and grounding procedures per paragraph 2-8b while refueling shall be mandatory, regardless of the amount of fuel to be dispensed, due to the dangers of static electricity. Bond the fuel nozzle ground wire to the aircraft before bringing nozzle in contact with the aircraft.**

- (10) Attach single point nozzle (fig. 2-34) ground wire to aircraft. Connect single point nozzle to adapter on aircraft. Open nozzle by turning lever on side of nozzle.

- (11) Unreel deadman control hose and activate deadman control S by depressing control lever. Meter inlet gage (fig. 2-15) should indicate a minimum of 25 psi. Should gage not indicate a minimum of 25 psi, shut down operation and contact unit maintenance.

- (12) Release deadman control S at end of operation, and adjust engine to idle speed (1000-1200 rpm). Rewind the deadman control hose.

- (13) Close single point nozzle. First disconnect single point nozzle from aircraft, then disconnect the nozzle ground wire.

- (14) Evacuate hose (para 2-14d).

- (15) Rewind the 2½-inch hose (para 2-11). Tighten hose reel lock.

- (16) Close all valves and shut off engine (para 2-10d).

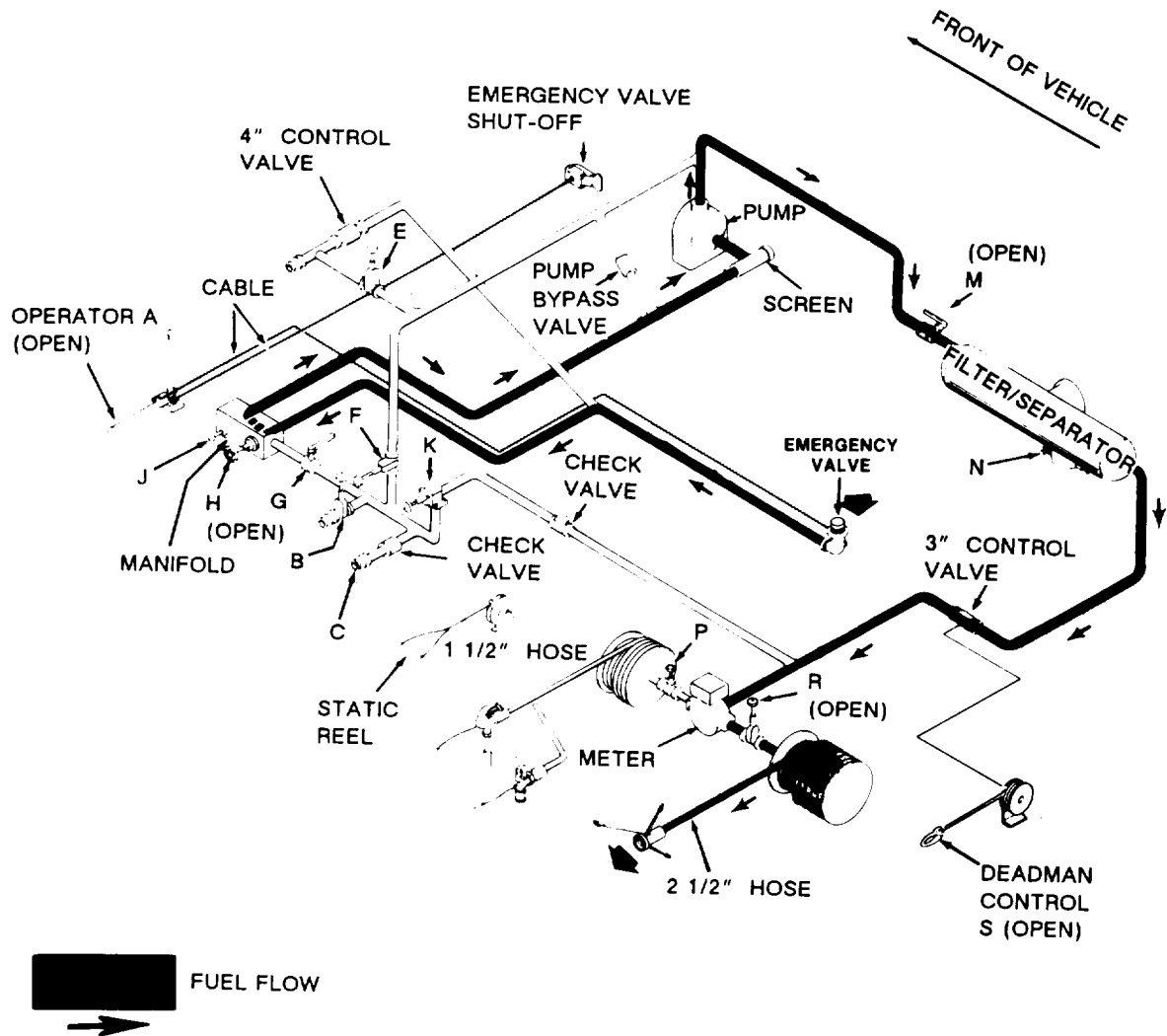

Figure 2-37. Single Point Underwing Fuel Dispensing Flow Diagram (M970 and M970A1).

TA502276

**WARNING**

**DO NOT** let go of the static reel cable when rewinding until the ball stop is firmly touching the reel. Failure to follow this warning may cause injury to personnel.

(17) Disconnect static reel cable first from aircraft, and then from grounding stud. Rewind static reel.

**WARNING**

**Hose reel cabinet door is heavy—use two hands when opening and closing. Use latches to lock door. Do not slam.**

(18) Close hose reel cabinet door and latch it in place.

(19) Store and cover fire extinguishers.

c. *Aircraft Overwing/Closed Circuit Fuel Dispensing Operation.* The overwing fuel dispensing operation is used to fuel winged aircraft through a fill port on top of aircraft wings. The closed circuit fuel dispensing operation is used to fuel helicopters. Fuel is pumped through the filter/separator, a meter, and a hose reel to the aircraft or helicopter (fig. 2-38). Fuel dispensing operation is as follows:

- (1) Review instructions in paragraph 2-8.

**WARNING**

**Hose reel cabinet door is heavy- use two hands when opening and closing. Use latches to lock door. Do not slam.**

- (2) Open hose reel cabinet door. Pull release cable and lift door with both hands.

- (3) Ensure that all valves are closed.

- (4) Unreel the static reel cable and connect first to grounding stud and then to aircraft.

- (5) Remove fire extinguishers and bring to point of operation.

- (6) Start engine (para 2-10) and when warm adjust engine speed to 1000-1200 rpm.

- (7) Open valves A (para 2-11f), H, M, and P. Reset the meter to zero by pushing the meter reset knob (fig. 2-15) and turning clockwise.

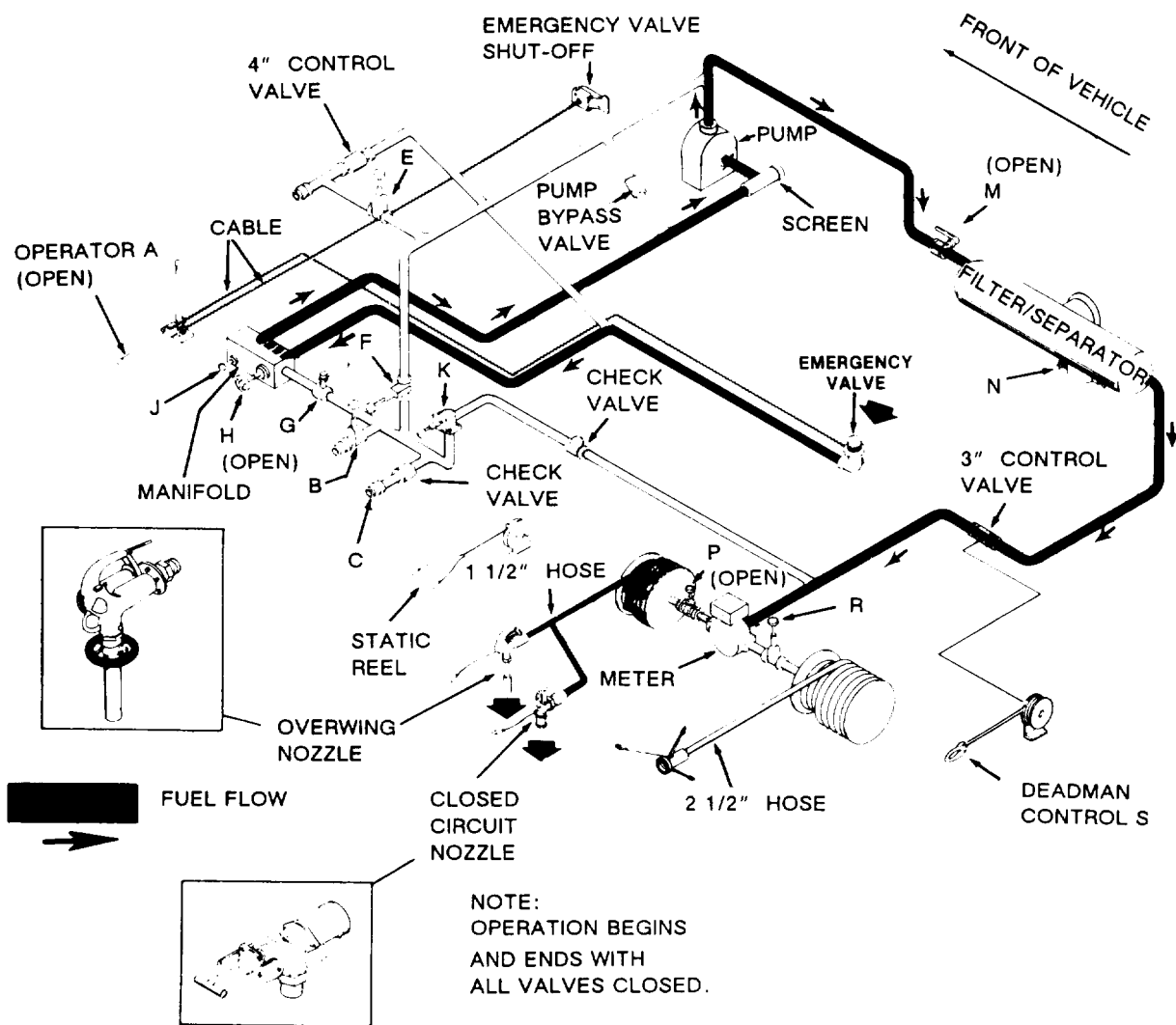

Figure 2-38. Aircraft Overwing/Closed Circuit (Helicopter) Fuel Dispensing Flow Diagram.

TA099720



**NOTE**

**If 2½ inch hose was used before using 1½ inch hose, depress and hold deadman release plunger in the hose reel cabinet (fig. 2-1 5) for 5-10 seconds to deactivate the deadman system. If this procedure is not followed, no fuel will flow to 1½-inch hose.**

(8) Adjust engine throttle for desired flow rate (table 2-2).

(9) Release lock (para 2-11) on 1½-inch hose reel. Unreel hose far enough to reach aircraft.

**WARNING**

**Bonding of the semitrailer to aircraft and grounding procedures per paragraph 2-8b while refueling shall be mandatory, regardless of the amount of fuel to be dispensed, due to the dangers of static electricity. Bond the fuel nozzle ground wire to the aircraft before bringing nozzle in contact with the aircraft.**

(10) Before removing aircraft fill cap, attach nozzle (fig. 2-38) ground wire to aircraft.

(11) Insert overwing nozzle into fill port of aircraft, or connect closed circuit nozzle to helicopter (fig. 2-38). Squeeze nozzle control handle on closed circuit nozzle (fig. 2-39). Complete extension of red indicator indicates no flow.

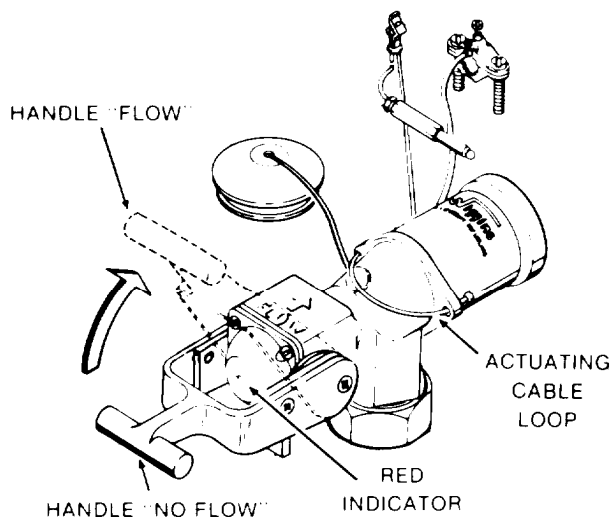

TA099721

**Figure 2-39. Closed Circuit Nozzle Operation.**

(12) At end of operation, release overwing nozzle trigger or return closed circuit nozzle control handle to the no flow position.

**NOTE**

**Do not disconnect nozzle ground wire before removing nozzle. Always remove nozzle first.**

(13) Remove overwing nozzle or disconnect closed circuit nozzle by pulling actuating cable loop (fig. 2-39). Reinstall aircraft fill cover.

(14) Evacuate hose (para 2-14d).

(15) Rewind the 1½-inch hose (para 2-11). Tighten hose reel lock.

(16) Close all valves and shut off engine (para 2-10d).

**WARNING**

**DO NOT let go of the static reel cable when rewinding until the ball stop is firmly touching the reel. Failure to follow this warning may cause injury to personnel.**

(17) Disconnect the static reel cable first from aircraft and then from grounding stud. Rewind the static reel.

**WARNING**

**Hose reel cabinet door is heavy - use two hands when opening and closing. Use latches to lock door. Do not slam.**

(18) Close hose reel cabinet door and latch it in place.

(19) Store and cover fire extinguishers.

*d. Defueling Operation With 2½-inch Hose. This operation is used to remove fuel from aircraft. The fuel is pumped from the aircraft through a filter/separator, a meter, a hose reel for the 2½-inch hose, a bottom load adapter, and into the tank (fig. 2-40). Operating instructions are as follows:*

**NOTE**

**A defueling hose must be available at the site. The semitrailer does not include a defueling hose.**

(1) Review instructions in paragraph 2-8.

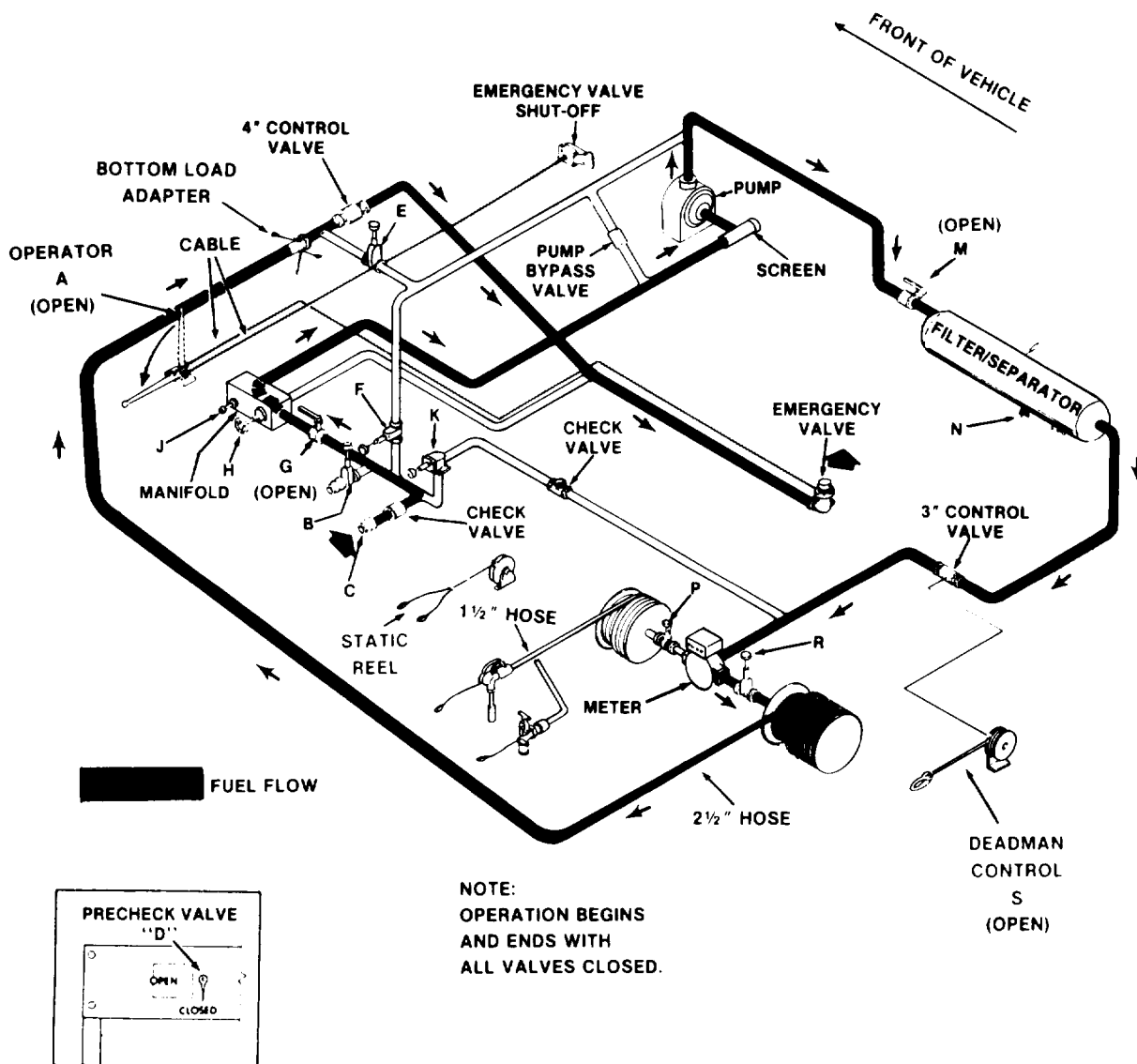

TA502277

Figure 2-40. Diagram for Refueling Using 2½-inch Hose (M970 and M970A1).

**WARNING**

**Hose reel cabinet door is heavy - use two hands when opening and closing. Use latches to lock door. Do not slam.**

(2) Open hose reel cabinet door. Pull release cable and open door with both hands.

(3) Ensure that all valves are closed.

(4) Remove fire extinguishers and take them to point of operation.

(5) Start engine (para 2-10) and when warm adjust engine speed to 1000-1200 rpm.

**WARNING**

**Bonding of the semitrailer to aircraft and grounding procedures per paragraph 2-8b while refueling shall be mandatory, regardless of the amount of fuel to be dispensed, due to the dangers of static electricity. Bond the fuel nozzle ground wire to the aircraft before bringing nozzle in contact with the aircraft.**

(6) Unreel static reel cable and connect first to grounding stud, then to aircraft.

(7) Release lock (para 2-11) on the 2½-inch hose reel and unreel to full length. Remove the dust cap on the bottom load adapter and connect single point nozzle to bottom load adapter. Open single point nozzle by turning handle on side of the nozzle.

(8) The defueling hose will be provided at operation site. Remove dust cap from outlet C and connect defueling hose to inlet. Next connect the hose.

**NOTE**

**Make sure valve E is closed and remains closed during entire operation.**

(9) Open valves A (para 2-11f), G, M, and R. Reset the meter to zero by pushing in reset knob (fig. 2-15) and turning clockwise.

(10) Set engine throttle at desired flow rate (table 2-2).

(11) Unreel deadman control S. Squeeze the trigger on deadman control to start fuel flow. Meter inlet pressure gage (fig. 2-15) should be indicating a minimum of 25 psi. If a minimum of 25 psi is not indicated, shutdown operation and contact unit maintenance.

**WARNING**

**When filling tank by means of defueling, a test of the precheck system is mandatory. If this system is not functioning, stop all operations. Determine the problem and have it corrected by a qualified technician. Failure of automatic shut-off to function may result in uncontrolled fuel spillage and danger of fire and explosion.**

(12) Shortly after flow has begun, turn precheck valve D to the OPEN position to precheck the automatic

shut-off float. After about 20–25 seconds flow should stop to indicate that the float is working properly (para 2-11g).

**NOTE**

**When tank is full, flow should stop automatically.**

(13) Close precheck valve D to the CLOSED position. Fuel flow will resume in about 20 seconds.

(14) At end of operation, release deadman control S and adjust engine to idle speed (1000-1200 rpm). Rewind the deadman control hose.

(15) First remove the defueling hose from aircraft, then remove the hose ground wire. Disconnect the defueling hose from inlet C. Replace the dust cap to outlet c.

(16) Close the single point nozzle and disconnect the nozzle from the bottom load adapter. Replace dust caps on single point nozzle and bottom load adapter.

(17) Evacuate hose (para 2-14d)

(18) Rewind the 2-inch hose (para 2-11). Tighten hose reel lock.

(19) Close all valves and shut off engine (para 2-10d).

**WARNING**

**DO NOT let go of the static reel cable when rewinding until the ball stop is firmly touching the reel. Failure to follow this warning may cause injury to personnel.**

(20) Disconnect the ground connection first from the aircraft, then from the grounding stud. Rewind the static reel cable.

**WARNING**

**Hose reel cabinet door is heavy-use two hands when opening and closing. Use latches to lock door. Do not slam.**

(21) Close hose reel cabinet door and latch it in place.

(22) Store and cover fire extinguishers.

e. *Defueling Operation With 1½-inch Hose.* This operation is used to remove fuel from an aircraft. The fuel is pumped from the aircraft through a filter/separator, a

meter, a hose reel for the 1½-inch hose, a bottom load adapter, and into bottom of tank (fig. 2-41). Operating instructions are as follows:

**NOTE**

- The converter (fig. 2-41 ) must be installed onto the overwing nozzle for this operation. Remove spout from overwing nozzle and install converter.
- A defueling hose must be available at the site. The semitrailer does not include a defueling hose.

(1) Review instructions in paragraph 2-8,

**WARNING**

**Hose reel cabinet door is heavy-use two hands when opening and closing. Use latches to lock door. Do not slam.**

(2) Open hose reel cabinet door. Pull release cable and lift door with both hands.

(3) Ensure that all valves are closed.

(4) Remove fire extinguishers and take to point of operation.

(5) Start engine (para 2-10) and when warm adjust engine speed to 1000-1200 rpm.

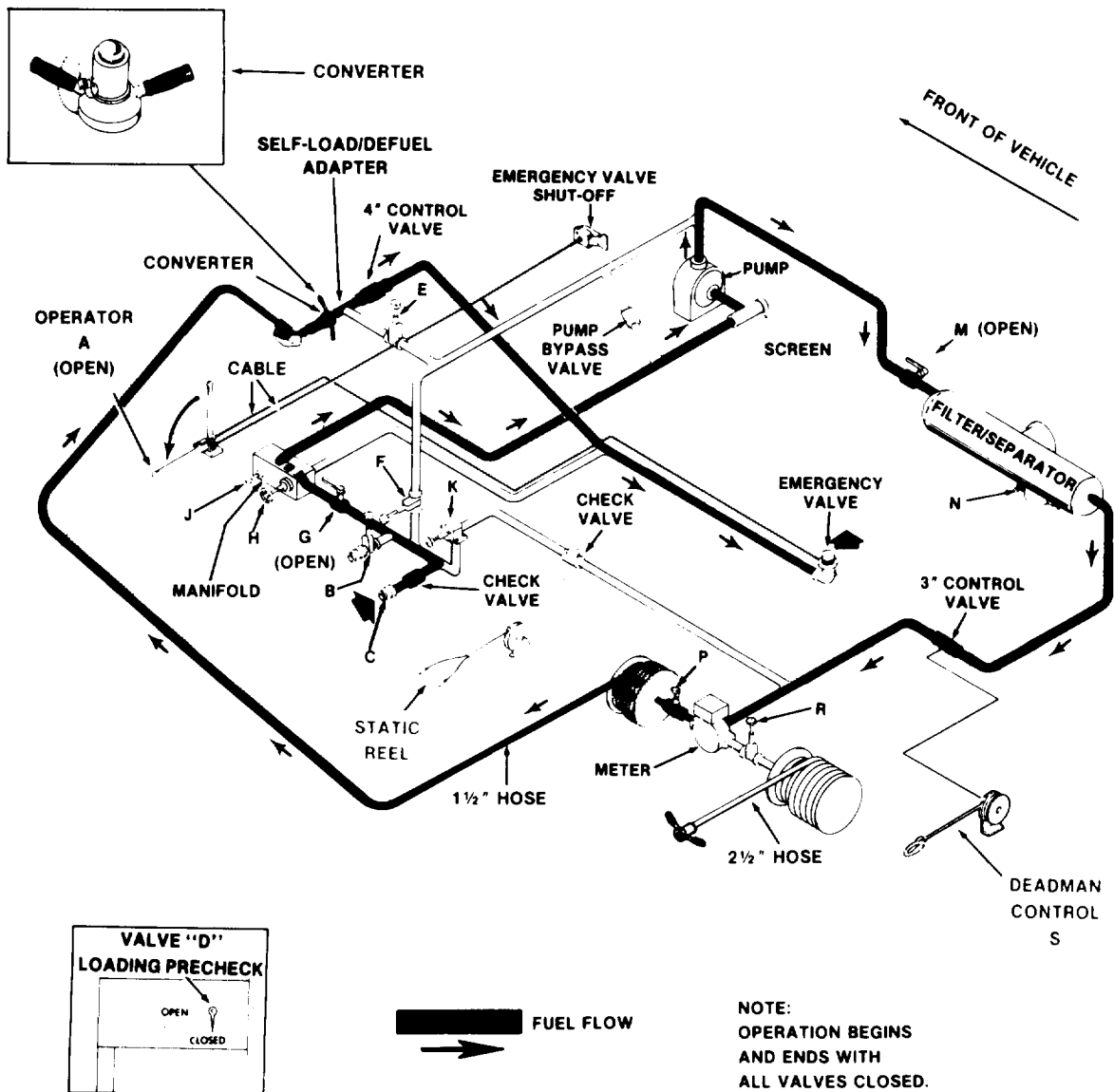

Figure 2-41. Diagram for Defueling Using 1½-inch hose (M970 and M970A1).

TA502278

**WARNING**

**Bonding of the semitrailer to aircraft and grounding procedures as in paragraph 2-8b while refueling shall be mandatory, regardless of the amount of fuel to be dispensed, due to the dangers of static electricity. Bond the fuel nozzle ground wire to the aircraft before bringing nozzle in contact with the aircraft.**

(6) Unreel static reel cable and connect it first to grounding stud, then to aircraft.

(7) Release lock (para 2-11) on the 1½-inch hose reel, and unreel all hose. Remove the dust cap from the bottom load adapter and connect converter to the adapter.

(8) Remove dust cap from inlet C and connect defueling hose to inlet. Next connect the defueling hose ground wire to the aircraft, then connect the hose.

**NOTE**

**Make sure valve E is closed and remains closed during entire operation.**

(9) Open valves A (para 2-11f), G, M, and P. Reset the meter to zero by pushing in reset knob (fig. 2-15) and turning clockwise.

**NOTE**

**If 2½-inch hose was used before using 1½-inch, depress and hold deadman release plunger in the hose reel cabinet (fig. 2-15) for 5-10 seconds to deactivate the deadman system. If this procedure is not followed, no fuel will flow to 1½-inch hose.**

(10) Set engine throttle at desired flow rate (table 2-2). Squeeze trigger on overwing nozzle.

**WARNING**

**When filling tank by means of defueling, a test of the precheck system is mandatory. If this system is not functioning, stop all operations. Determine the problem and have it corrected by a qualified technician. Failure of automatic shut-off to function may result in uncontrolled fuel spillage and danger of fire and explosion.**

(11) Shortly after flow has begun, turn precheck valve D to the OPEN position to precheck the automatic

shut-off float. If float is functional, flow should stop after about 20-25 seconds (para 2-11g).

**NOTE**

**When tank is full, flow should stop automatically.**

(12) Close precheck valve D to the CLOSED position. Fuel flow will resume in about 20 seconds.

(13) At end of operation, release the trigger on the overwing nozzle, and adjust engine to idle speed (1000-1200 rpm).

(14) Remove the defueling hose from aircraft first, then remove the hose ground wire. Disconnect the defueling hose from inlet C. Replace the dust cap to outlet C.

**WARNING**

**DO NOT let go of the static reel cable when rewinding until the ball stop is firmly touching the reel. Failure to follow this warning may cause injury to personnel.**

(15) Disconnect the ground connection first from the aircraft, then from the grounding stud. Rewind the static reel cable.

(16) Disconnect the overwing nozzle/converter from the bottom load adapter. Replace dust cap on bottom load adapter.

(17) Evacuate hose (para 2-14d).

(18) Rewind the 1½-inch hose (para 2-11). Tighten hose reel lock.

(19) Close all valves and shut off engine (para 2-10d).

(20) Remove converter from overwing nozzle and install spout to nozzle.

**WARNING**

**Hose reel cabinet door is heavy-use two hands when opening and closing. Use latches to lock door. Do not slam.**

(21) Close hose reel cabinet door and latch it in place.

(22) Store and cover fire extinguishers.

*f. Recirculation Operation With 2½-inch Hose.* This operation is used when the fuel in the tank must be refiltered. The fuel is recirculated through the filter/separator, meter, hose reel for the 2½-inch hose, and recirculation fitting on side of tank (fig. 2-42). Operation instructions are as follows:

(1) Review instructions in paragraph 2-14.

**WARNING**

**Hose reel cabinet door is heavy— use two hands when opening and closing. Use latches to lock door. Do not slam.**

(2) Open hose reel cabinet door. Pull release cable and lift door with both hands.

(3) Ensure that all valves are closed.

(4) Unreel the static reel cable and connect to an approved earth ground (fig. 2-7).

(5) Remove fire extinguishers and take them to the point of operation.

(6) Start engine (para 2-10) and when warm adjust engine speed to 1000-1200 rpm.

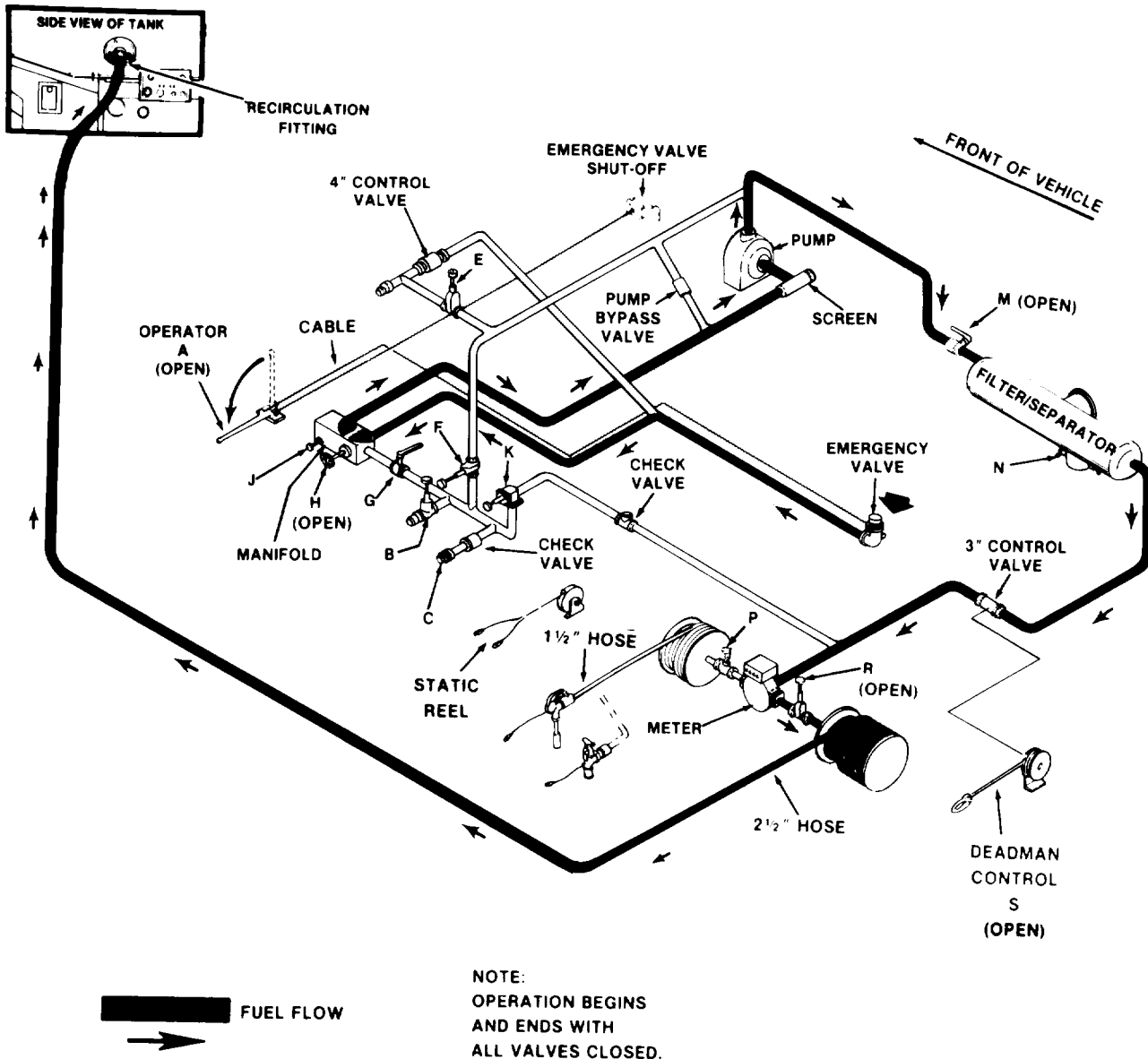

TA502279

Figure 2-42. Diagram for Recirculating Fuel Using 2½-inch Hose (M970 and M970A1).

(7) Release lock (para 2-11) on the 2½-inch hose reel and unreel all hose. Remove dust cap on the recirculation fitting (fig. 2-11), and connect single point nozzle to the fitting. Open single point nozzle by turning handle (fig. 2-34) on side of nozzle.

(8) Open valves A (para 2-11f), H, M, and R.

(9) Set engine throttle at desired flow rate (table 2-2).

**NOTE**

**Air source must be available for deadman operation.**

(10) Unreel deadman control S. Squeeze the trigger on deadman control to start fuel flow. Meter inlet pressure gage should be indicating a minimum of 25 psi. If a minimum of 25 psi is not indicated, shut down operation and contact unit maintenance.

(11) At end of operation, release deadman control S and adjust engine to idle speed (1000-1200 rpm). Rewind the deadman control.

(12) Close the single point nozzle and disconnect nozzle from recirculation fitting. Replace dust cap on recirculation fitting.

(13) Evacuate hose (para 2-14d).

(14) Rewind the 2-inch hose (para 2-11). Tighten hose reel lock.

(15) Close all valves and shut off engine (para 2-10d).

**WARNING**

**DO NOT let go of the static reel cable when rewinding until the ball stop is firmly touching the reel. Failure to follow this warning may cause injury to personnel.**

(16) Disconnect the static reel cable from its ground connection and rewind.

**WARNING**

**Hose reel cabinet door is heavy- use two hands when opening and closing. Use latches to lock door. Do not slam.**

(17) Close hose reel cabinet door and latch it in place.

(18) Store and cover fire extinguishers.

*g. Recirculation Operation With 1½-inch Hose.* This operation is used when the fuel in the tank must be refiltered. The fuel is recirculated through the filter/separator, meter, hose reel for the 1½-inch hose, and recirculation fitting on side of tank (fig. 2-43). Operation instructions are as follows:

**NOTE**

**The converter (fig. 2-43) must be installed onto the overwing nozzle for this operation. Remove spout from overwing nozzle and install quick disconnect converter (fig. 2-44).**

(1) Review instructions in paragraph 2-14.

**WARNING**

**Hose reel cabinet door is heavy- use two hands when opening and closing. Use latches to lock door. Do not slam.**

(2) Open hose reel cabinet door. Pull release cable and lift door with both hands.

(3) Ensure that all valves are closed.

(4) Unreel the static reel cable and connect to an approved earth ground (fig. 2-7).

(5) Remove fire extinguishers and bring them to point of operation.

(6) Start engine (para 2-10) and when warm adjust engine speed to 1000-1200 rpm.

(7) Release lock (para 2-11) on the 1½-inch hose reel, and unreel all hose. Remove the dust cap on the recirculation fitting (fig. 2-12) and connect the converter to the fitting.

(8) Open valves A (para 2-11f), H, M, and F?

**NOTE**

**If 2½-inch hose was used before using the 1½-inch hose, depress and hold deadman release plunger in the hose reel cabinet (fig. 2-14) for 5-10 seconds to deactivate the deadman system. If this procedure is not followed, no fuel will flow to the 1½-inch hose.**

(9) Set engine throttle at desired flow rate (table 2-2). Squeeze trigger on overwing nozzle.

(10) At end of operation, release the trigger on the overwing nozzle, and adjust engine to idle speed (1000-1200 rpm).

(11) Disconnect the overwing nozzle/converter from the recirculation fitting. Reinstall dust cap to fitting.

(12) Evacuate hose (para 2-14d).

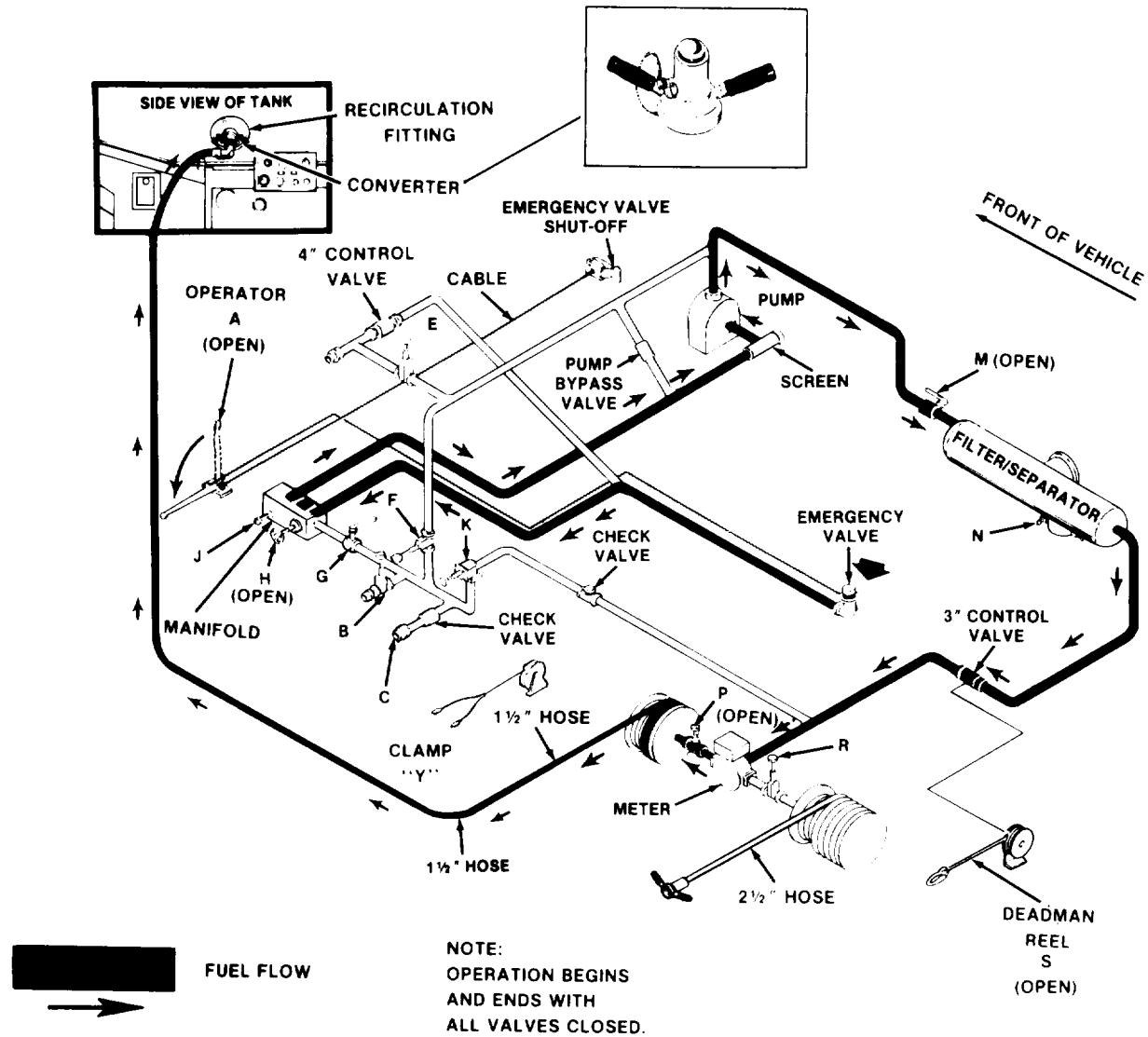

Figure 2-43. Flow Diagram for Recirculating Fuel Using 1/2-inch Hose (M970 and M970A1).

TA099725

(13) Rewind the 1/2-inch hose (para 2-11). Tighten hose reel lock.

(14) Close all valves and shut off engine (para 2-10).

(15) Remove converter from overwing nozzle and install spout to nozzle.

(16) Disconnect the static reel cable from its ground connection and rewind.

**WARNING**

**Hose reel cabinet door is heavy-use two hands when opening and closing. Use latches to lock door. Do not slam.**

(17) Close hose reel cabinet door and latch it in place,

(18) Store and cover fire extinguishers.



1. Remove spout from overwing nozzle.

2. Install quick disconnect converter.

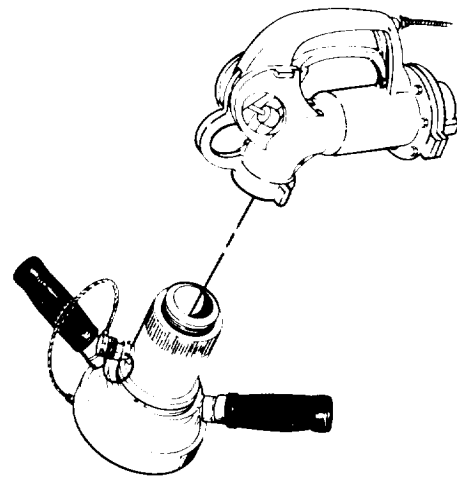
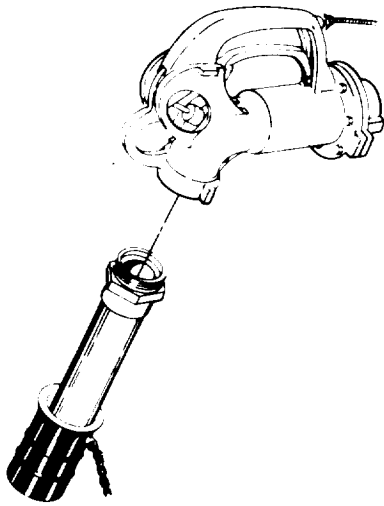

TA099726

Figure 2-44. Installing Converter Onto Overwing Nozzle.

**2-19. Refuel on the Move (ROM) Assembly and Operating Procedures (M969 and M969A1) (Fig. 2-45)**

**WARNING**

**Fuel handlers must wear appropriate safety equipment during fueling operations to avoid injury.**

**NOTE**

**Components of the Refuel Assembly Kit (NSN 4730-01-295-1842) are listed in Appendix D.**

- a. Select refuel site and park fuel tank semitrailer at right side of road.
- b. Open Refuel on the Move (ROM) accessory container. Unpack instruction sheets and inventory sheet. Take inventory of components of container.
- c. Unload the three 4-inch hoses from hose troughs. Remove dust cap from valve B and the three hoses. Connect the three hoses together and attach one end to valve B.

**NOTE**

**The number of fueling points to be connected and operated may vary. Additional hose sections of the type provided in the kit may be connected to the basic ROM system for additional reach if needed to satisfy special deployment conditions.**

- d. Lay out ROM parts on ground per Instruction Drawing 12356089.

**NOTE**

**Apply teflon tape to all male coupling threads. Reapply as needed during subsequent deployments to ensure proper seal of connections.**

- e. Attach parts, starting with large 4-inch tee, to the 4-inch hose from the fuel tank semitrailer. If equipped, open valve on tee assemblies before operating.
- f. Remove dust caps and assemble parts. Ensure that camlock clamps hold parts together tightly.
- g. Place fire extinguishers at refuel sites (8). Place a ground rod at each refuel site and pound 18 inches into ground with slide hammer on ground rod.
- h. Place nozzles on ground rod handle.

## NOTES:

1. THIS DRAWING IS FOR INSTALLATION PURPOSES ONLY.
2. ALL CAPS AND PLUGS SHALL BE ATTACHED TO THE COUPLINGS BY MEANS OF THE CHAINS.
3. SEE TM 9-2330-356-14, FIG.2-11 FOR DETAILS.
4. REMOVE CAP (MS27028-17) FROM CAM LOCK PORT MARKED OUTLET B. CONNECT HOSE (11685834) PER MIL-C-27487.
5. 2-HOSE - 11685835 AND HOSE - 11685834 ARE PART OF O.V.E. ON M969/M969A1.

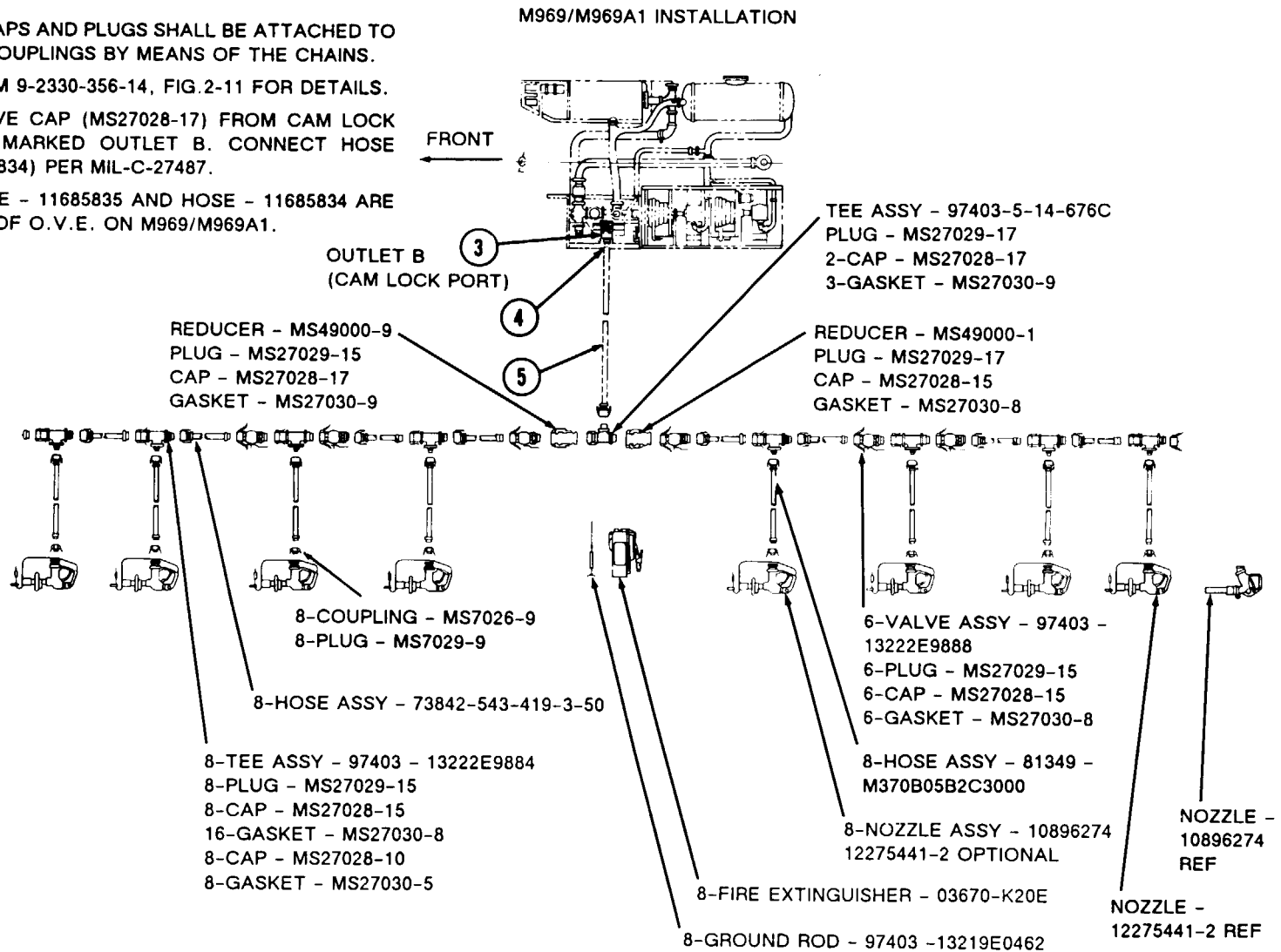

Figure 2-45. Refuel on the Move (ROM).

TA504709

- i.* Obtain the (8) grounding wires from organic equipment and attach one alligator clamp to ground rod. Also, ensure that fuel tank semitrailer has been grounded.
- j.* Store unused plugs, dust caps, etc., in ROM accessory container.
- k.* Prepare fuel tank semitrailer for filtered fuel bulk unload (para 2-16).
- l.* Start engine and raise speed to proper RPM. Check ROM system for fuel leaks under pressure. Correct leaks as necessary.
- m.* Refuel convoy vehicles per mission requirements. Use ground rod wire to ground refueled vehicle.

- n.* When deactivating refuel site:

(1) Start engine and put fuel tank semitrailer into defueling mode. Progressively open nozzles beginning with those farthest from tanker using a drip container to catch any spillage.

(2) Disassemble all components after draining fuel back into tanker.

(3) Stop engine. Replace vehicle hoses and dust caps. Put dust caps and plugs on all ROM components and stow in ROM accessory container. Refer to storage diagram on container.

### Section III. OPERATION UNDER UNUSUAL CONDITIONS

#### 2-20. General

- a.* You must follow the approved practices and precautions. A detailed study of FM 21-305 and FM 55-30 is essential for use of this material under unusual conditions.
- b.* For description of operations in extreme cold, refer to FM 9-207.
- c.* Under sandy, dusty, mud, water, or salt water operating conditions, inspect, clean, and lubricate parts frequently.

#### 2-21. Extreme Cold Weather Operation

- a.* *Drain Water.* During cold weather operations, the accumulated water in the semitrailer fueling system may freeze. It is important to drain the water from the entire system after each operation to prevent damage to the fueling system components (para 2-13 *d*). Remove drain plug from engine fuel tank and drain any accumulated water from tank.

#### **WARNING**

**A warm air blower maybe used to preheat the brake shoes. Make sure the heater itself is at least 50-ft from semitrailer to prevent fuel vapor from semitrailer entering blower heating chamber. Failure to follow this warning may result in serious injury or death to personnel.**

- b.* *Frozen Parts.* The driver must be alert to frozen systems while pulling the semitrailer after shutdown. Congealed lubricants may cause failure of parts. Tires

frozen to the ground, or frozen to the shape of the flat spot while under-inflated must be considered. One or more brake shoes may be frozen fast and may require preheating to avoid damage to the internal parts and brake drums.

- c.* *Driving.* Refer to FM 21-305 for special instructions on driving hazards in snow, ice, and unusual terrain encountered under extreme cold weather conditions.

- d.* *Engine Operation.* Refer to paragraph 2-10 for operating instructions of the engine in extreme cold weather.

#### 2-22. Extreme Hot Weather Operation

- a.* *Parking.* When practical, park the semitrailer under cover to protect it from sun, sand, and dust.
- b.* *Engine Operation.* Refer to paragraph 2-10 for engine operating instructions in extremely hot weather.
- c.* *Effects of Humidify.* Vehicles parked for long periods in hot, humid weather are subject to rapid rusting and accumulation of fungus growth. Inspect often, clean, and lubricate to prevent deterioration.

#### 2-23. Operation on Unusual Terrain

- a.* *Sand.* Inspection, cleaning, and lubrication of working parts must be made often when operating under extremely dusty or sandy conditions. Wheel bearings should be cleaned and repacked with lubricants as specified on the lubrication order after operation under extremely dusty or sandy conditions.
- b.* *Rocky Terrain.* Use extreme caution when traveling over rocky terrain. Specified tire inflation should

be maintained to minimize the possibility of internal rupture of the tire and damage to the tube.

*c. Flooded Road Surfaces.* When the unit is subjected to flooded road surfaces, the vehicle can withstand a depth of 24-inches. However, wheel bearings should be cleaned and repacked if this happens. Electrical

cables and terminals must be protected by spraying with ignition insulation compound.

*d. Salt Water Operation.* Salt water causes corrosion of exposed parts. After operation is complete, wash with fresh water.

## CHAPTER 3 OPERATOR/CREW MAINTENANCE INSTRUCTIONS

---

### Section I. LUBRICATION INSTRUCTIONS

#### **3-1. Lubrication**

This section has lubrication requirements for the semitrailers.

*a.* For lubrication under usual conditions, refer to figures 3-1 through 3-6 for general areas and lubrication intervals. Refer to figures 3-7 through 3-21 for specific lubrication points.

*b.* For instructions on lubrication in weather below 0°F, refer to FM 9-207.

*c.* For lubrication after fording, refer to TM 9-238.

*d.* After operating under dusty or sandy conditions, clean and inspect all lubrication points for fouled lubricants. Lubricate if fouled.

## LUBRICATION CHART

### SEMITRAILER, TANK: 5000 GAL. BULK HAUL, SELF LOAD/UNLOAD M967 (2330-01-050-5632)

Intervals (on-condition or hard time) and related man-hour times are based on normal operation. The man-hour time specified is the time you need to do all services prescribed for a particular interval. Decrease the intervals if your lubricants are contaminated, or if you are operating equipment under adverse conditions, including longer-than-usual operating hours. The intervals may be extended during periods of low activity. If extended, adequate preservation precautions must be taken. Dotted leader lines indicate lubrication is required on both sides of the equipment.

tilated area. Avoid contact with skin, eyes, and clothes, and DO NOT breathe vapors. DO NOT use near open flame or excessive heat. The solvent's flash point is 100°F-130°F (38°C-59°C). If you become dizzy while using cleaning solvent, immediately get fresh air and medical help. If solvent contacts eyes, immediately wash your eyes and get medical aid.

**WARNING**

Dry cleaning solvent P-D-680 is toxic and flammable. Always wear protective goggles and gloves, and use only in a well-ven-

The lowest level of maintenance authorized to lubricate a point is indicated in parentheses by use of the following: (C) Operator/Crew; or (O) Unit Maintenance. Clean all fittings and area around lubrication points with dry cleaning solvent (Item 11, Appendix E) or equivalent before lubricating equipment. After lubrication, wipe off excess oil or grease to prevent accumulation of foreign matter.

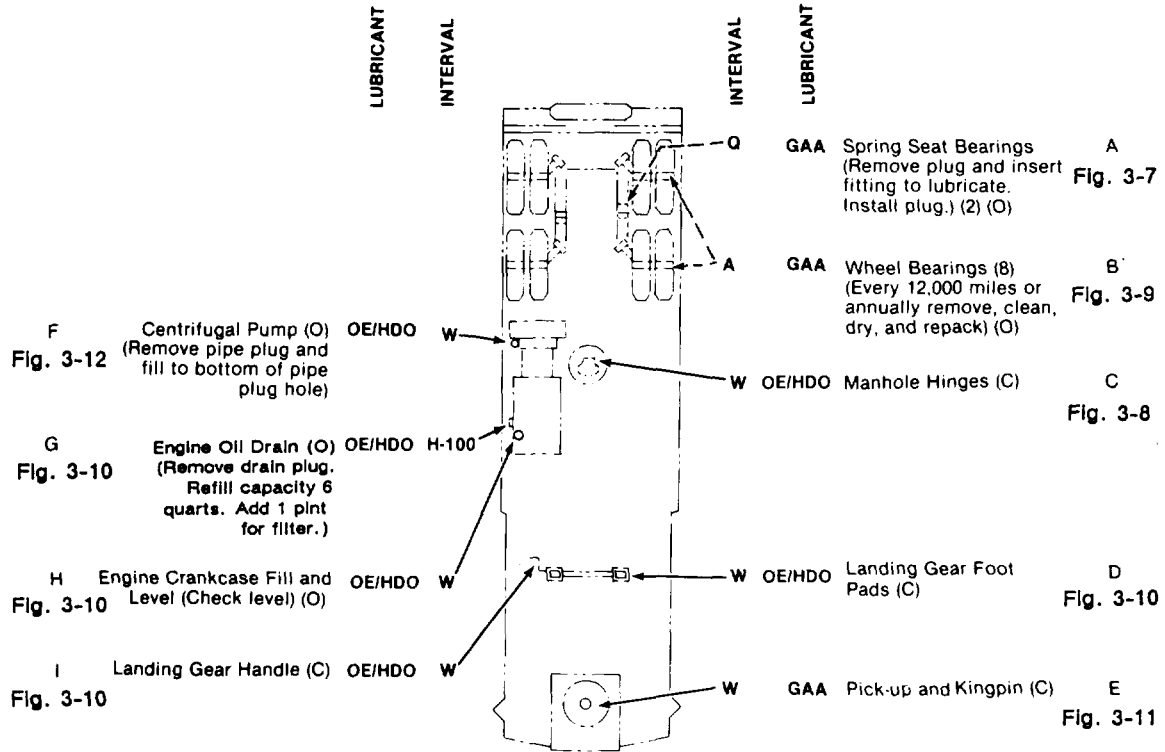

TOTAL MAN - HR		TOTAL MAN - HR	
INTERVAL	MAN - HR	INTERVAL	TOTAL
A	1.0	Q	0.2
W	0.6	100	0.3

TA502280

*Figure 3-1. Lubrication Chart (M967) (Sheet 1 of 2).*

KEY

LUBRICANT	REFILL CAPACITY (APP)	EXPECTED TEMPERATURE			INTERVAL
		Above 32° F	40° F to -10° F	0° F to -65° F	
<b>OE/HDO</b> (MIL-L-2104) Lubricating oil internal combustion engine. or <b>OEA</b> (MIL-L-46167) Engine crankcase	6 quarts, plus 1 pint for oil filter.	OE/HDO-30	OE/HDO-20	OEA	For Arctic Operation, Refer to FM 9-207 D - Daily W - Weekly Q - Quarterly A - Annually H - Hours
<b>GAA</b> (MIL-G-10924) Grease, Automotive and artillery	As req'd	All Temperature			

Figure 3-1. Lubrication Chart (M967) (Sheet 2 of 2).

### LUBRICATION CHART

**SEMITRAILER, TANK: 5000 GAL. BULK HAUL,  
SELF LOAD/UNLOAD M967A1  
(2330-01-155-0046)**

Intervals (on-condition or hard time) and related man-hour times are based on normal operation. The man-hour time specified is the time you need to do all services prescribed for a particular Interval. Decrease the intervals if your lubricants are contaminated, or if you are operating equipment under adverse conditions, including longer-than-usual operating hours. The intervals may be extended during periods of low activity. If extended, adequate preservation precautions must be taken. Dotted leader lines indicate lubrication is required on both sides of the equipment.

tilated area. Avoid contact with skin, eyes, and clothes, and DO NOT breathe vapors. DO NOT use near open flame or excessive heat. The solvent's flash point is 100°F-130°F (38°C-59°C). If you become dizzy while using cleaning solvent, immediately get fresh air and medical help. If solvent contacts eyes, immediately wash your eyes and get medical aid.

**WARNING**

Dry cleaning solvent P-D-680 is toxic and flammable. Always wear protective goggles and gloves, and use only in a well-ven-

The lowest level of maintenance authorized to lubricate a point is indicated in parentheses by use of the following: (C) Operator/Crew; or (O) Unit Maintenance. Clean all fittings and area around lubrication points with dry cleaning solvent (Item 11, Appendix E) or equivalent before lubricating equipment. After lubrication, wipe off excess oil or grease to prevent accumulation of foreign matter.

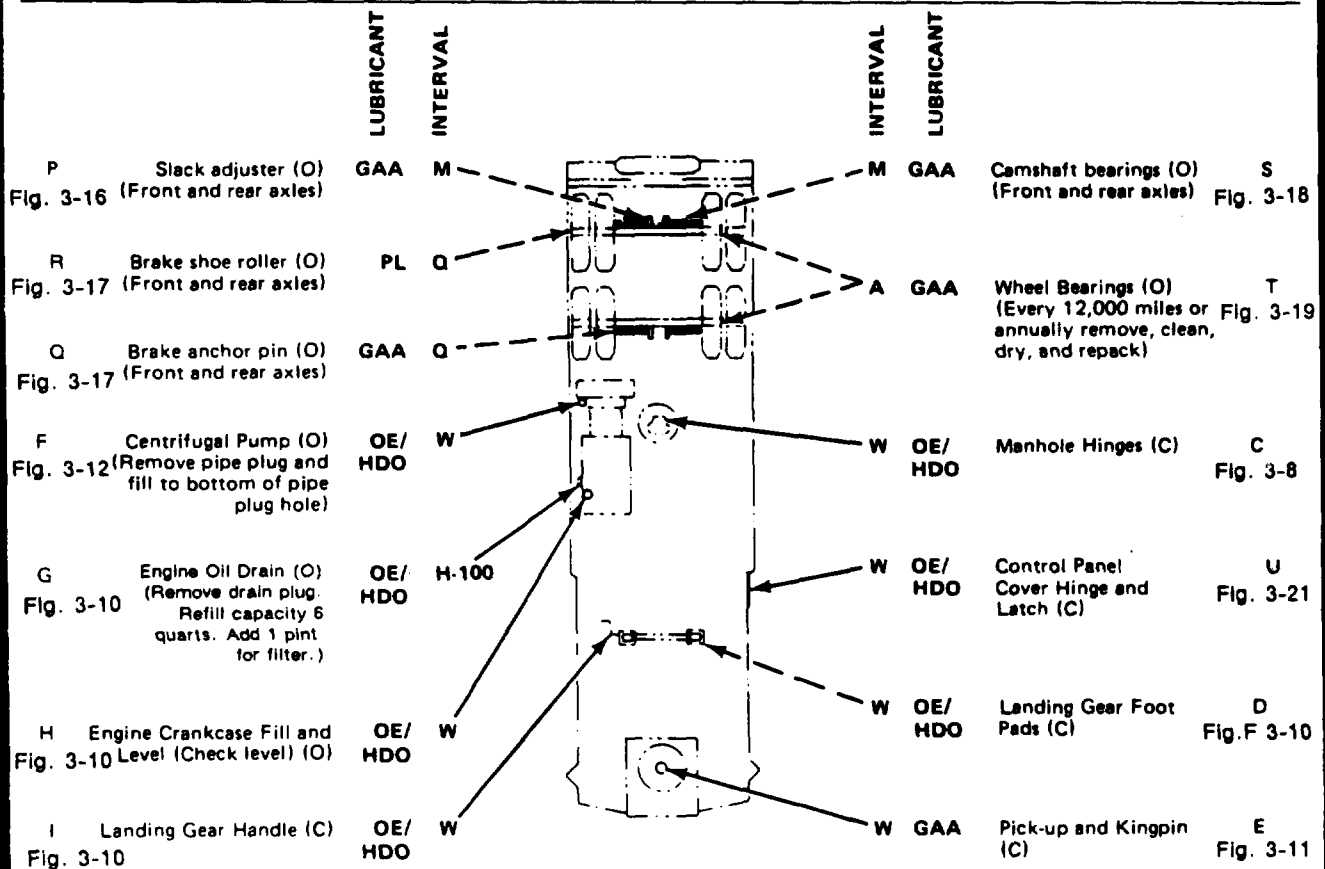

TOTAL MAN - HR		TOTAL MAN - HR	
INTERVAL	MAN - HR	INTERVAL	MAN - HR
A	1.0	Q	0.4
W	0.6	H-100	0.3
M	0.4		

TA502282

Figure 3-2. Lubrication Chart (M967A1) (Sheet 1 of 2).



KEY

LUBRICANT	REFILL CAPACITY (APP)	EXPECTED TEMPERATURE			INTERVAL
		Above 32° F	40° F to -10° F	0° F to -65° F	
<b>OE/HDO</b> Lubricating oil (MIL-L-2104) Internal combustion engine. or <b>OEA</b> Engine (MIL-L-48187) crankcase	6 quarts, plus 1 pint for oil filter.	OE/HDO-30	OE/HDO-20	OEA	D - Daily W - Weekly M - Monthly Q - Quarterly A - Annually H - Hours
<b>GAA</b> Grease, Auto- (MIL-G-10924) motive and artillery	As req'd	All Temperature			
<b>PL</b> Preservative (PL-S-VV-L-800) oil or (PL-M-MIL-L-3150)		PL - Medium	PL - Special	PL - Special	

For Arctic Operation, Refer to FM 9-207

Figure 3-2. Lubrication Chart (M967A1) (Sheet 2 of 2).

### LUBRICATION CHART

#### SEMITRAILER, TANK: 5000 GAL. FUEL DISPENSING, AUTOMOTIVE M969 (2330-01-050-5634)

Intervals (on-condition or hard time) and related man-hour times are based on normal operation. The man-hour time specified is the time you need to do all services prescribed for a particular interval. Decrease the intervals if your lubricants are contaminated, or if you are operating equipment under adverse conditions, including longer-than-usual operating hours. The intervals may be extended during periods of low activity. If extended, adequate preservation precautions must be taken. Dotted leader lines indicate lubrication is required on both sides of the equipment.

illated area. Avoid contact with skin, eyes, and clothes, and DO NOT breathe vapors. DO NOT use near open flame or excessive heat. The solvent's flash point is 100°F-130°F (38°C-55°C). If you become dizzy while using cleaning solvent, immediately get fresh air and medical help. If solvent contacts eyes, immediately wash your eyes and get medical aid.

**WARNING**

Dry cleaning solvent P-D-680 is toxic and flammable. Always wear protective goggles and gloves, and use only in a well-ven-

The lowest level of maintenance authorized to lubricate a point is indicated in parentheses by use of the following: (C) Operator/Crew; or (O) Unit Maintenance. Clean all fittings and area around lubrication points with dry cleaning solvent (Item 11, Appendix E) or equivalent before lubricating equipment. After lubrication, wipe off excess oil or grease to prevent accumulation of foreign matter.

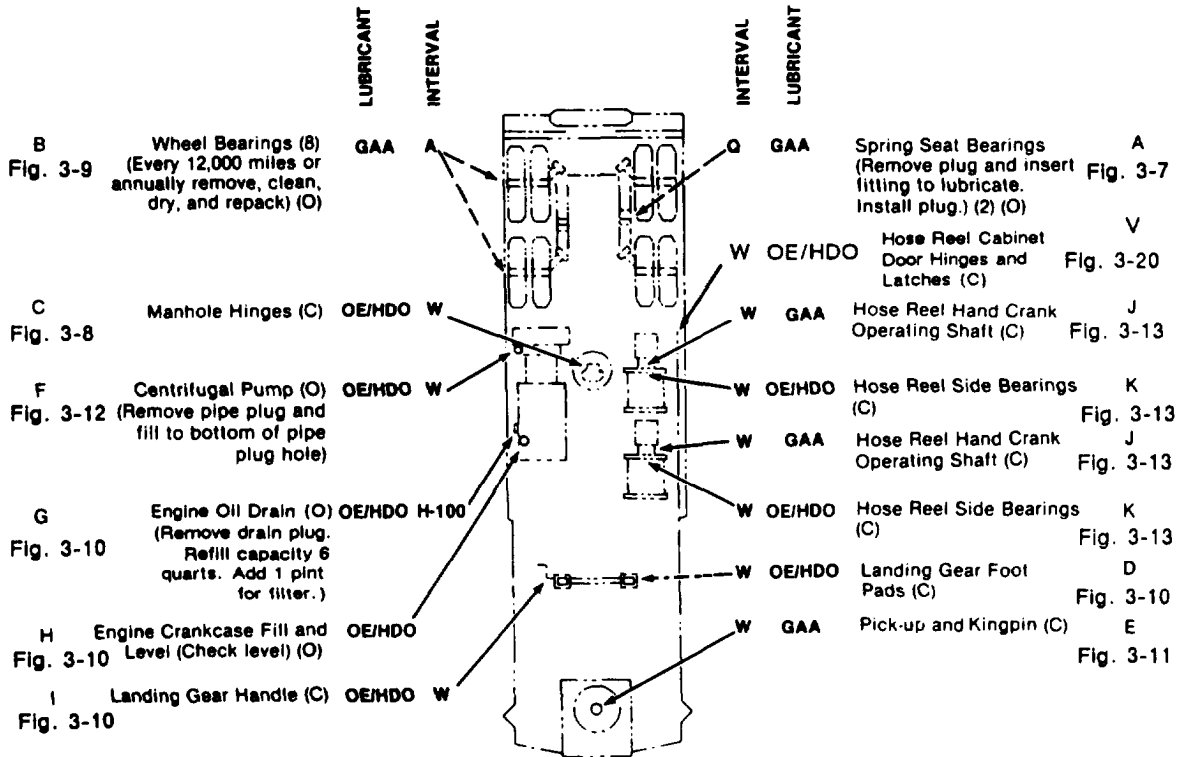

TOTAL MAN - HR		TOTAL MAN - HR	
INTERVAL	MAN - HR	INTERVAL	TOTAL
A	1.0	G	0.2
W	1.0	100	0.3

TA502284

Figure 3-3. Lubrication Chart (M969) (Sheet 1 of 2).

KEY

LUBRICANT	REFILL CAPACITY (APP)	EXPECTED TEMPERATURE			INTERVAL	
		Above 32° F	40° F to -10° F	0° F to -65° F		
<b>OE/HDO</b> (MIL-L-2104)  or  <b>OEA</b> (MIL-L-46167)	Lubricating oil internal combustion engine.  Engine crankcase	6 quarts, plus 1 pint for oil filter.	OE/HDO-30	OE/HDO-20	OEA	For Arctic Operation, Refer to FM 9-207  D - Daily W - Weekly Q - Quarterly A - Annually H - Hours
<b>GAA</b> (MIL-G-10924)	Grease, Automotive and artillery	As req'd	All Temperature			

Figure 3-3. Lubrication Chart (M969) (Sheet 2 of 2).

### LUBRICATION CHART

**SEMITRAILER, TANK: 5000 GAL. FUEL DISPENSING,  
AUTOMOTIVE M969A1  
(2330-01-155-0048)**

Intervals (on-condition or hard time) and related man-hour times are based on normal operation. The man-hour time specified is the time you need to do all services prescribed for a particular interval. Decrease the intervals if your lubricants are contaminated, or if you are operating equipment under adverse conditions, including longer-than-usual operating hours. The intervals may be extended during periods of low activity. If extended, adequate preservation precautions must be taken. Dotted leader lines indicate lubrication is required on both sides of the equipment.

illated area. Avoid contact with skin, eyes, and clothes, and DO NOT breathe vapors. DO NOT use near open flame or excessive heat. The solvent's flash point is 100°F-130°F (38°C-59°C). If you become dizzy while using cleaning solvent, immediately get fresh air and medical help. If solvent contacts eyes, immediately wash your eyes and get medical aid.

**WARNING**

Dry cleaning solvent P-D-680 is toxic and flammable. Always wear protective goggles and gloves, and use only in a well-ven-

The lowest level of maintenance authorized to lubricate a point is indicated in parentheses by use of the following: (C) Operator/Crew; or (O) Unit Maintenance. Clean all fittings and area around lubrication points with dry cleaning solvent (Item 11, Appendix E) or equivalent before lubricating equipment. After lubrication, wipe off excess oil or grease to prevent accumulation of foreign matter.

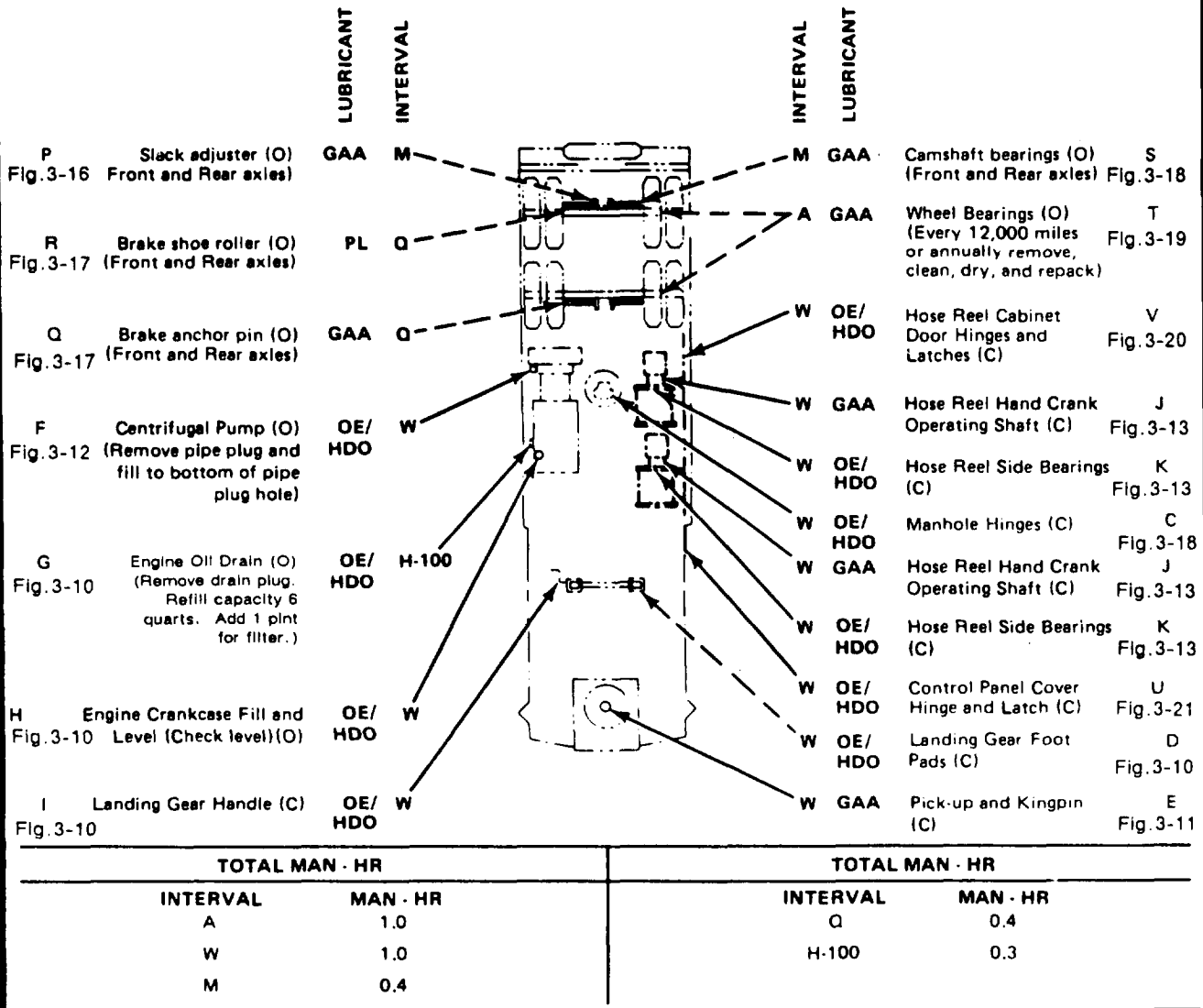

Figure 3-4. Lubrication Chart (M969A1) (Sheet 1 of 2).

TA502285

KEY

LUBRICANT	REFILL CAPACITY (APP)	EXPECTED TEMPERATURE			INTERVAL
		Above 32° F	40° F to -10° F	0° F to -65° F	
OE/HDO (MIL-L-2104) or OEA (MIL-L-46167)	Lubricating oil internal combustion engine. Engine crankcase 6 quarts, plus 1 pint for oil filter.	OE/HDO-30	OE/HDO-20	OEA	D - Daily W - Weekly M - Monthly Q - Quarterly A - Annually H - Hours
GAA (MIL-G-10924)	Grease, Automotive and artillery	As req'd All Temperature			
PL (PL-S-VV-L-800) or (PL-M-MIL-L-3150)	Preservative Oil	PL - Medium	PL - Special	PL - Special	

For Arctic Operation, Refer to FM 9-207

Figure 3-4. Lubrication Chart (M969A1) (Sheet 2 of 2).

### LUBRICATION CHART

#### SEMITRAILER, TANK: 5000 GAL. FUEL DISPENSING, UNDER/OVERWING AIRCRAFT M970 (2330-01-050-5635)

Intervals (on-condition or hard time) and related man-hour times are based on normal operation. The man-hour time specified is the time you need to do all services prescribed for a particular interval. Decrease the intervals if your lubricants are contaminated, or if you are operating equipment under adverse conditions, including longer-than-usual operating hours. The intervals may be extended during periods of low activity. If extended, adequate preservation precautions must be taken. Dotted leader lines indicate lubrication is required on both sides of the equipment.

**WARNING**

Dry cleaning solvent P-D-660 is toxic and flammable. Always wear protective goggles and gloves, and use only in a well-ven-

tilated area. Avoid contact with skin, eyes, and clothes, and DO NOT breathe vapors. DO NOT use near open flame or excessive heat. The solvent's flash point is 100°F-130°F (38°C-59°C). If you become dizzy while using cleaning solvent, immediately get fresh air and medical help. If solvent contacts eyes, immediately wash your eyes and get medical aid.

The lowest level of maintenance authorized to lubricate a point is indicated in parentheses by use of the following: (C) Operator/Crew; or (O) Unit Maintenance. Clean all fittings and area around lubrication points with dry cleaning solvent (Item 11, Appendix E) or equivalent before lubricating equipment. After lubrication, wipe off excess oil or grease to prevent accumulation of foreign matter.

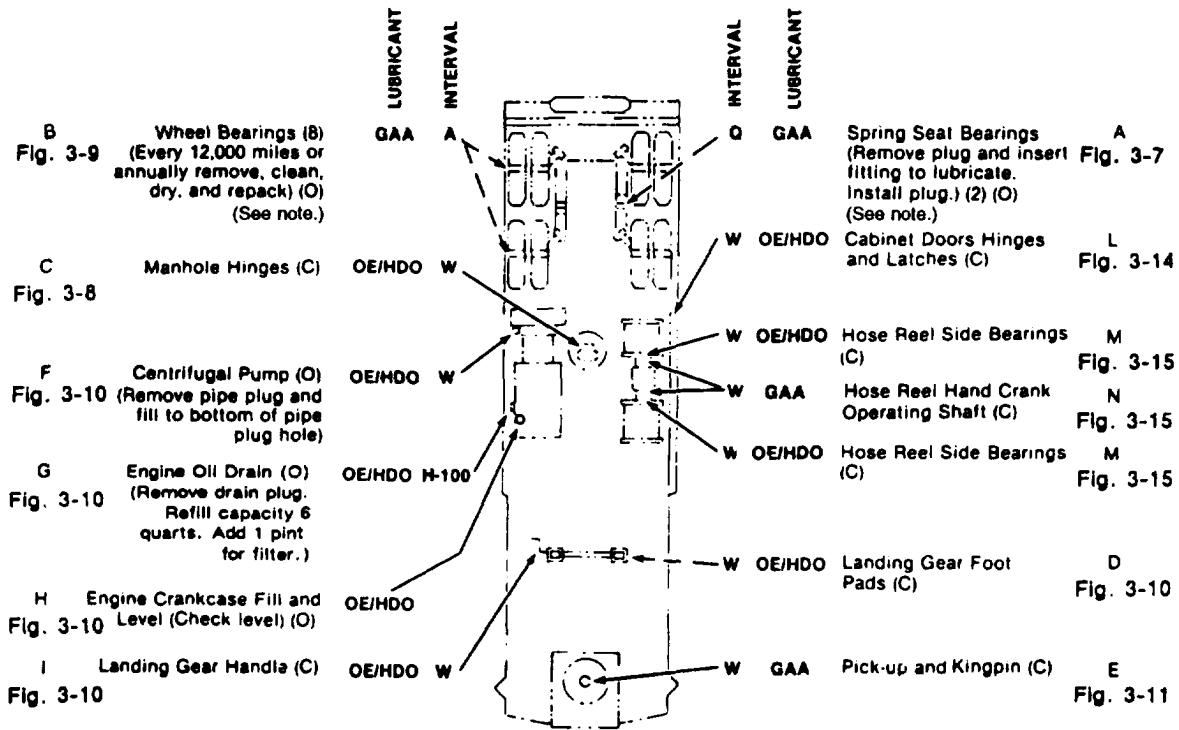

TOTAL MAN - HR		TOTAL MAN - HR	
INTERVAL	MAN - HR	INTERVAL	TOTAL
	1.0	Q	0.2
W	1.0	100	0.3

TA502287

Figure 3-5. Lubrication Chart (M970) (Sheet 1 of 2)

KEY

LUBRICANT		REFILL CAPACITY (APP)	EXPECTED TEMPERATURE			INTERVAL
			Above 32° F	40° F to -10° F	0° F to -65° F	
<b>OE/ND0</b> (MIL-L-2104)  or  <b>OE/A</b> (MIL-L-46167)	Lubricating oil internal combustion engine.  Engine crankcase	6 quarts, plus 1 pint for oil filter.	OE/ND0-30	OE/ND0-20	OE/A	For Arctic Operation, Refer to FM 9-207  D - Daily W - Weekly Q - Quarterly A - Annually H - Hours
<b>GAA</b> (MIL-G-10824)	Grease, Automotive and artillery	As req'd	All Temperature			

NOTE:

The Marine Corps M970 (SN TC-0843, TC-0844, and TC-103 thru TC-178) incorporates the M970A1 dolly with the M970 body. Refer to the M970A1 Lubrication Chart for the lubrication of the brake and suspension system components of this special model.

Figure 3-5 Lubrication Chart (M970) (Sheet 2 of 2).

### LUBRICATION CHART

#### SEMITRAILER, TANK: 5000 GAL. FUEL DISPENSING, UNDER/OVERWING AIRCRAFT M970A1 (2330-01-155-0047)

Intervals (on-condition or hard time) and related man-hour times are based on normal operation. The man-hour time specified is the time you need to do all services prescribed for a particular interval. Decrease the intervals if your lubricants are contaminated, or if you are operating equipment under adverse conditions, including longer-than-usual operating hours. The intervals may be extended during periods of low activity. If extended, adequate preservation precautions must be taken. Dotted leader lines indicate lubrication is required on both sides of the equipment.

tilated area. Avoid contact with skin, eyes, and clothes, and DO NOT breathe vapors. DO NOT use near open flame or excessive heat. The solvent's flash point is 100°F-130°F (38°C-59°C). If you become dizzy while using cleaning solvent, immediately get fresh air and medical help. If solvent contacts eyes, immediately wash your eyes and get medical aid.

**WARNING**

Dry cleaning solvent P-D-680 is toxic and flammable. Always wear protective goggles and gloves, and use only in a well-ven-

The lowest level of maintenance authorized to lubricate a point is indicated in parentheses by use of the following: (C) Operator/Crew; or (O) Unit Maintenance. Clean all fittings and area around lubrication points with dry cleaning solvent (Item 11, Appendix E) or equivalent before lubricating equipment. After lubrication, wipe off excess oil or grease to prevent accumulation of foreign matter.

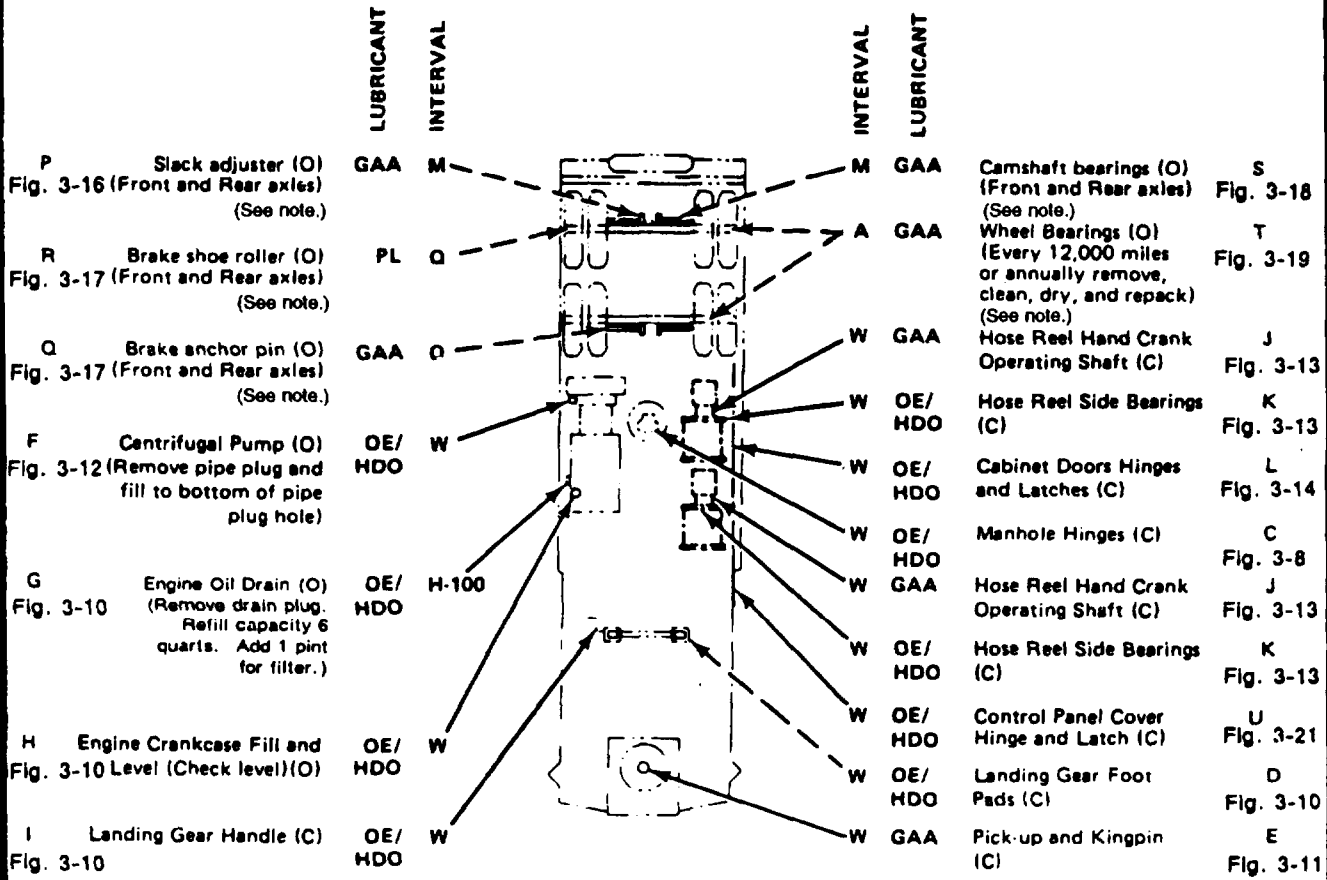

TOTAL MAN - HR		TOTAL MAN - HR	
INTERVAL	MAN - HR	INTERVAL	MAN - HR
A	1.0	Q	0.4
W	1.0	H-100	0.3
M	0.4		

TA502289

Figure 3-6. Lubrication Chart (M970A1) (Sheet 1 of 2).



KEY

LUBRICANT	REFILL CAPACITY (APP)	EXPECTED TEMPERATURE			INTERVAL	
		Above 32° F	40° F to - 10° F	0° F to - 65° F		
OE/MDO (MIL-L-2104) or OEA (MIL-L-46167)	Lubricating oil internal combustion engine. Engine crankcase 6 quarts, plus pint for oil filter.	OE/MDO-30	OE/MDO-20	OEA	For Arctic Operation, Refer to FM 9-207 D - Daily W - Weekly M - Monthly Q - Quarterly A - Annually H - Hours	
GAA (MIL-G-10924)	Grease, Automotive and artillery	As req'd				All Temperature
PL (PL-S-VV-L-800) or (PL-M-MIL-L-3150)	Preservative Oil	PL - Medium	PL - Special	PL - Special		

NOTE:

The Marine Corps M970 (SN TC-0843, TC-0844, and TC-103 thru TC-178) incorporates the M970A1 dolly with the M970 body. Items indicated on the Lubrication Chart apply to this Marine Corps M970 tanker.

Figure 3-6. Lubrication Chart (M970A1) (Sheet 2 of 2).

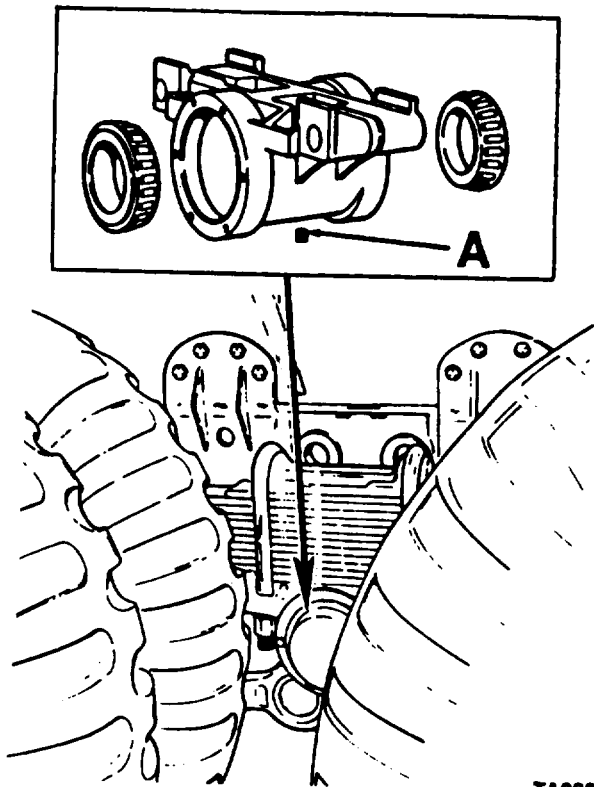

TA099733

Figure 3-7. Location of Lubrication Point for Spring Seat Bearings.

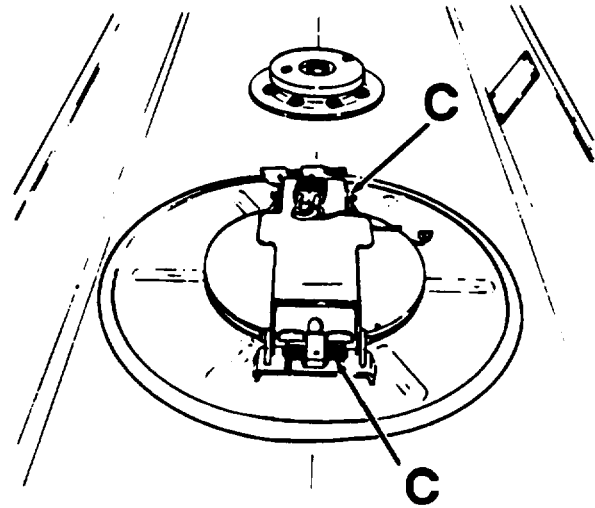

TA099734

Figure 3-8. Lubrication Points for Manhole Hinges.

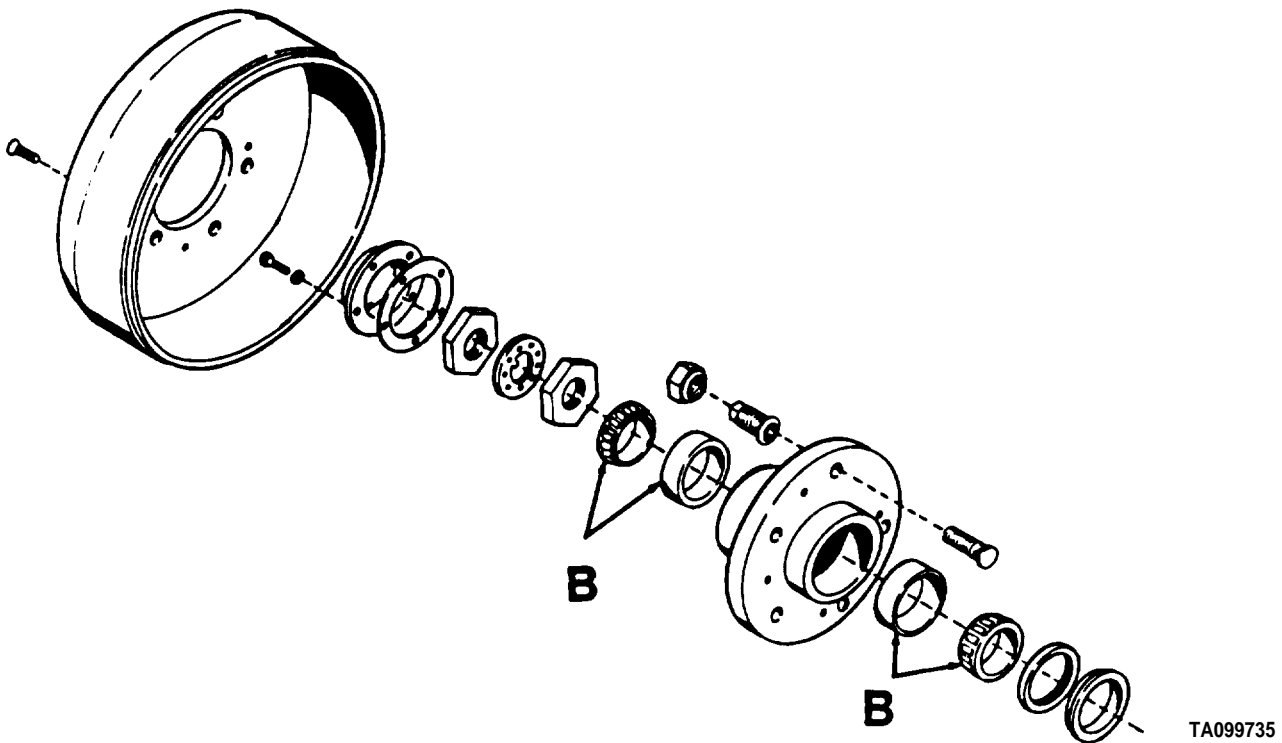

TA099735

Figure 3-9. Location of Wheel Bearings (M967, M969, M970 except M970 SN TC-0843, TC-0844, and TC-103 thru TC-178).

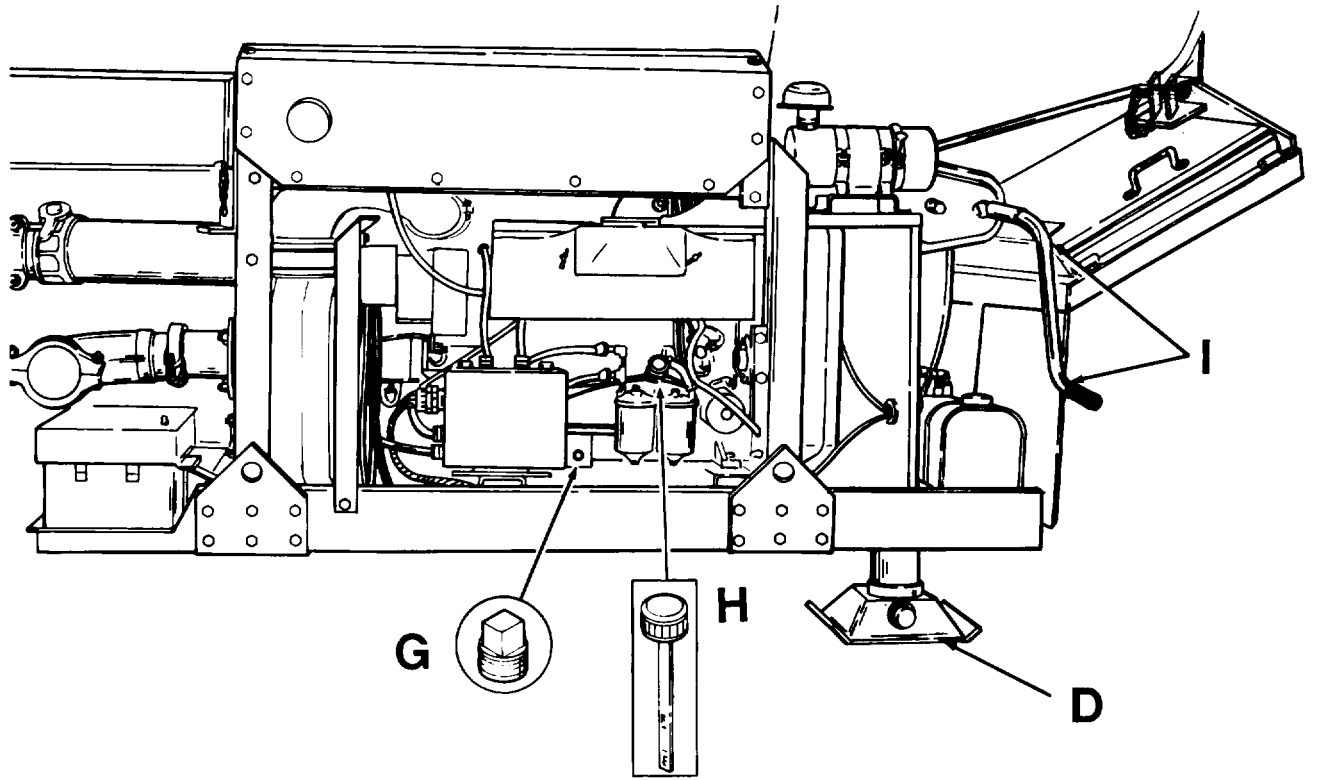

Figure 3-10. Engine and Landing Gear Lubrication Points.

TA502291

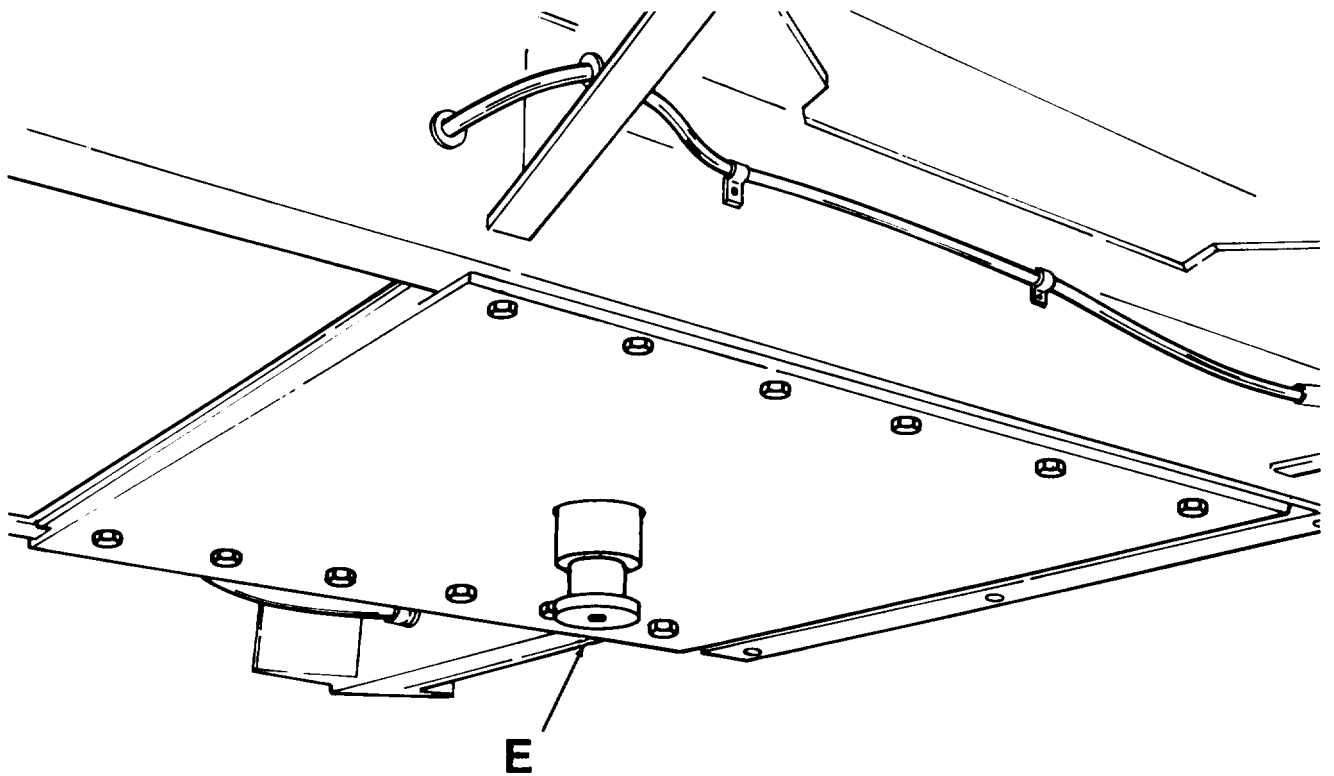
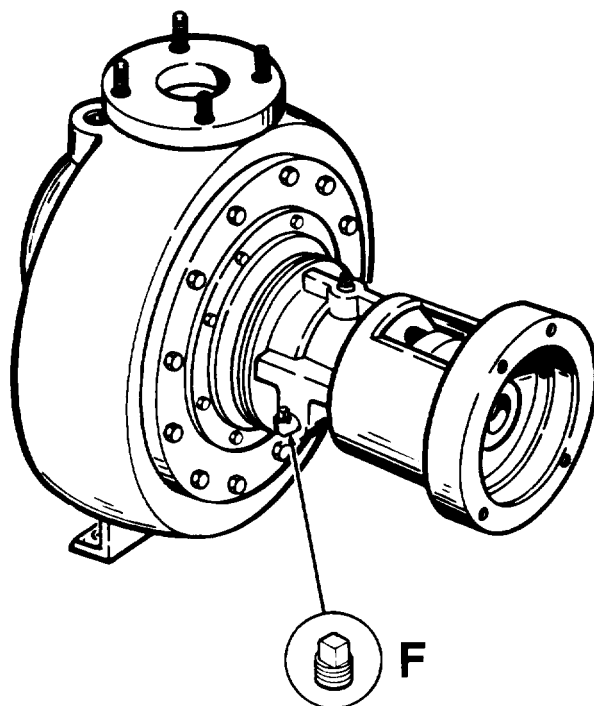

Figure 3-11. Lubrication of Pick-up and Upper Coupler (Kingpin) Plate.

TA502292



TA099738

Figure 3-12. Lubrication of Centrifugal Pump.

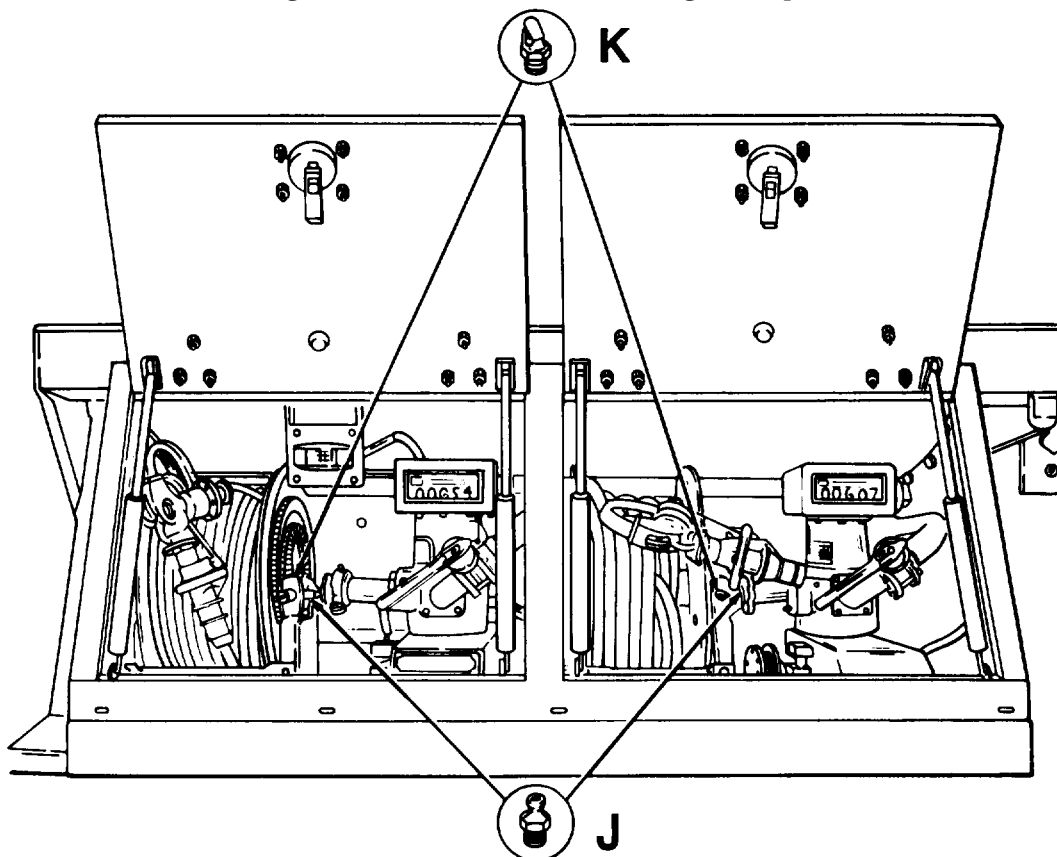

TA221177

Figure 3-13. Location of Hose Reel Hand Crank and Hose Reel Side Bearing Lubrication Points (M969 and M969A1).

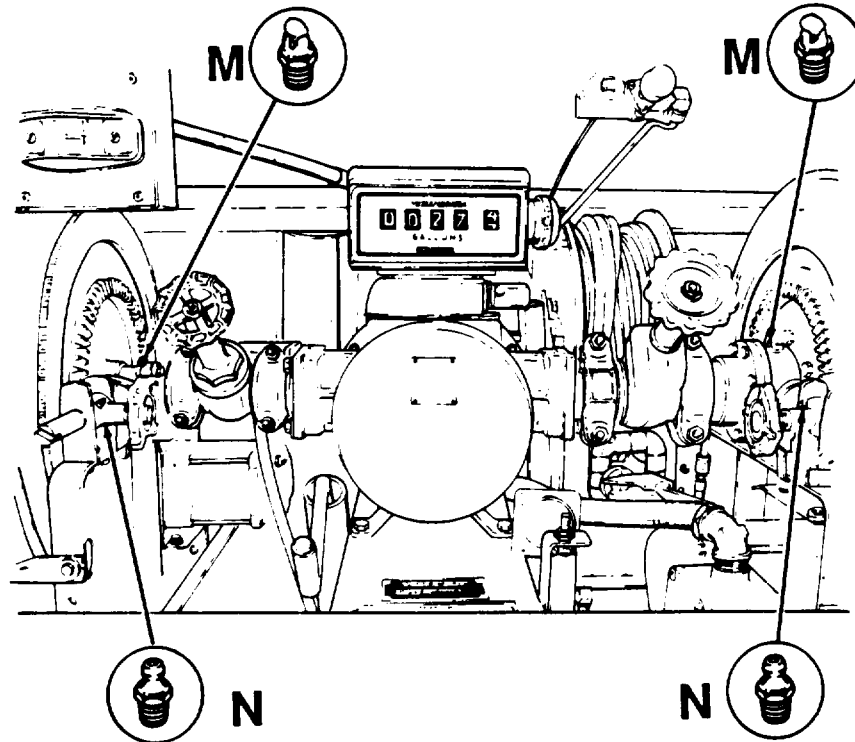

TA099740

Figure 3-14. Location of Hose Reel Hand Crank and Hose Reel Side Bearing Lubrication Points (M970 and M970A1).

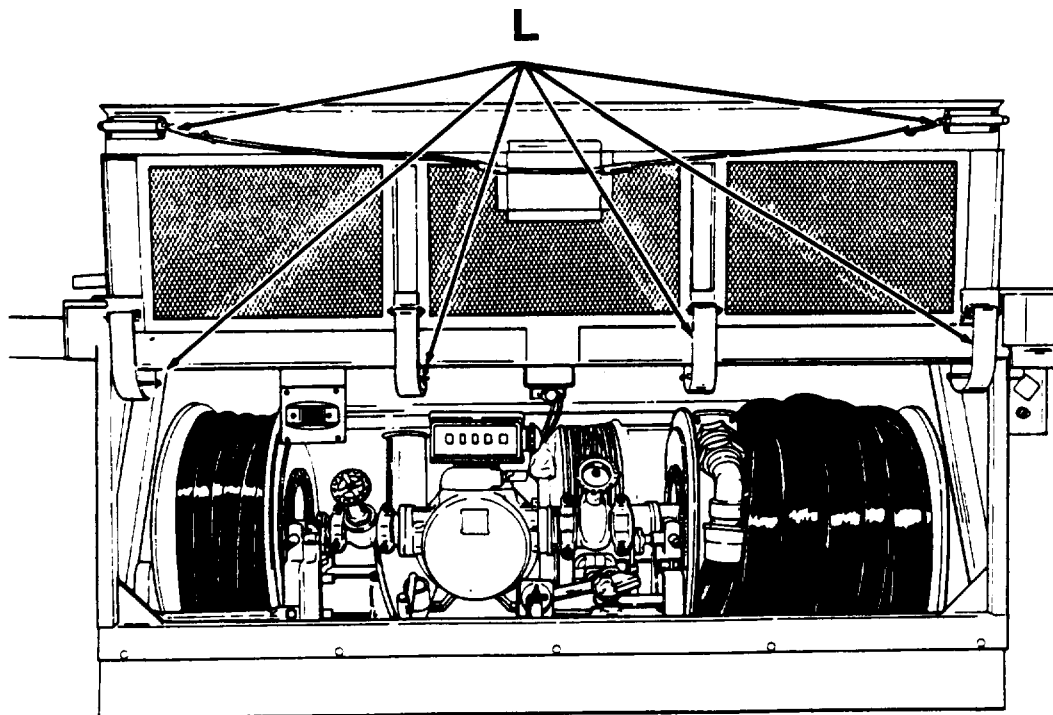

TA099741

Figure 3-15. Location of Cabinet Door Hinges and Latches (M970 and M970A1).

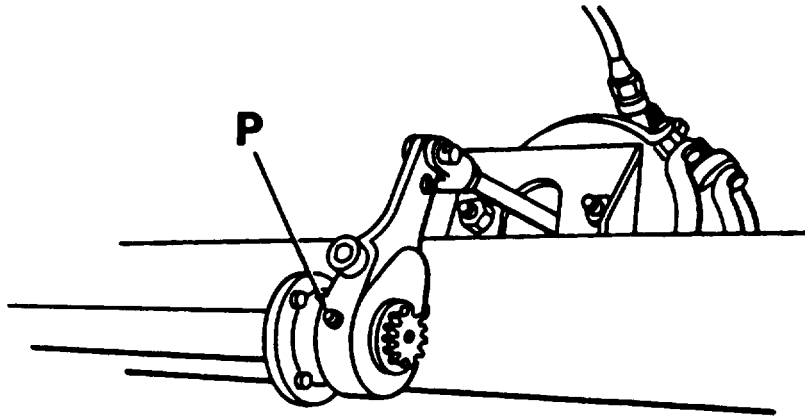

**TA22117B**

*Figure 3-16. Location of Lubrication Fitting for Slack Adjuster (M967A1, M969A1, and M970A1 including M970 SN TC-0843, TC-0844, and TC-103 thru TC-178).*

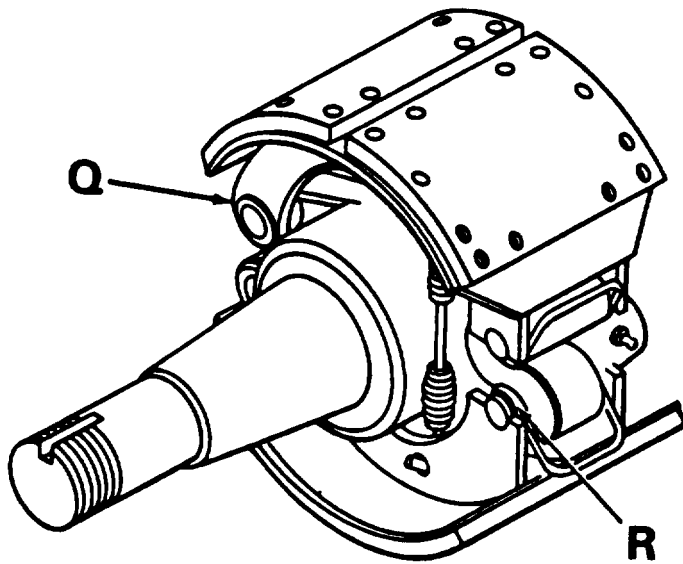

**TA22179**

*Figure 3-17. Location of Brake Shoe Roller and Brake Anchor Pin (M967A1, M969A1, and M970A1 including M970 SN TC-0843, TC-0844, and TC-103 thru TC-178).*

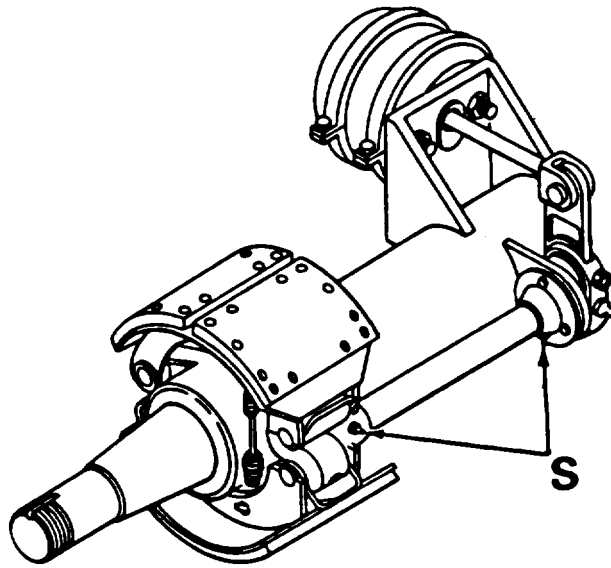

TA502293

Figure 3-18. Location of Lubrication Fitting for Slack Adjuster (M967A1, M969A1, and M970A1 including M970 SN TC-0843, TC-0844, and TC-103 thru TC-178).

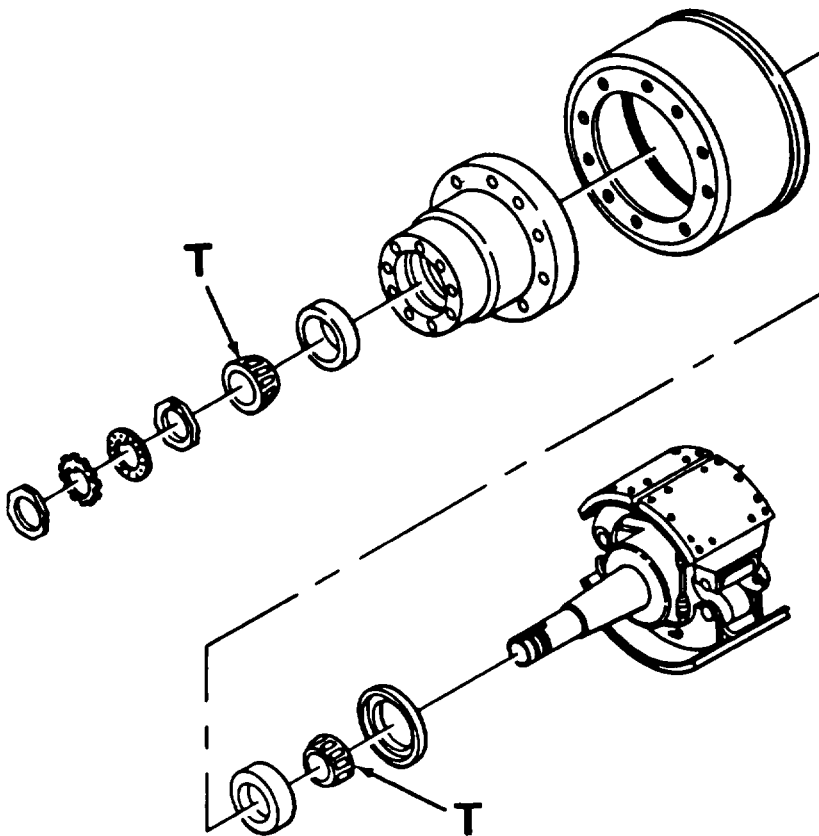

TA221181

Figure 3-19. Location of Lubrication Fitting for Slack Adjuster (M967A1, M969A1, and M970A1 including M970 SN TC-0843, TC-0844, and TC-103 thru TC-178).

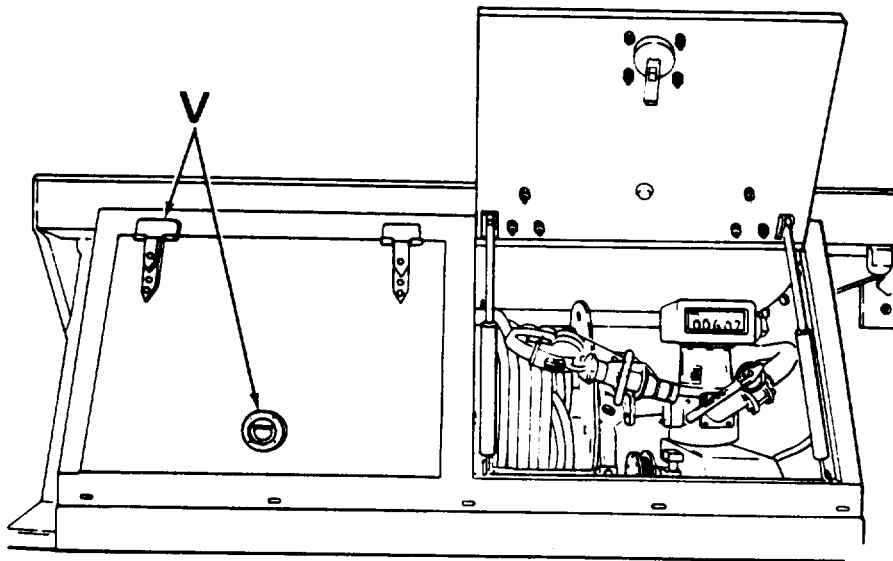

*Figure 3-20. Location of Hose Reel Cabinet Door Hinges and Latches (M969 and M969A1).*

TA221182

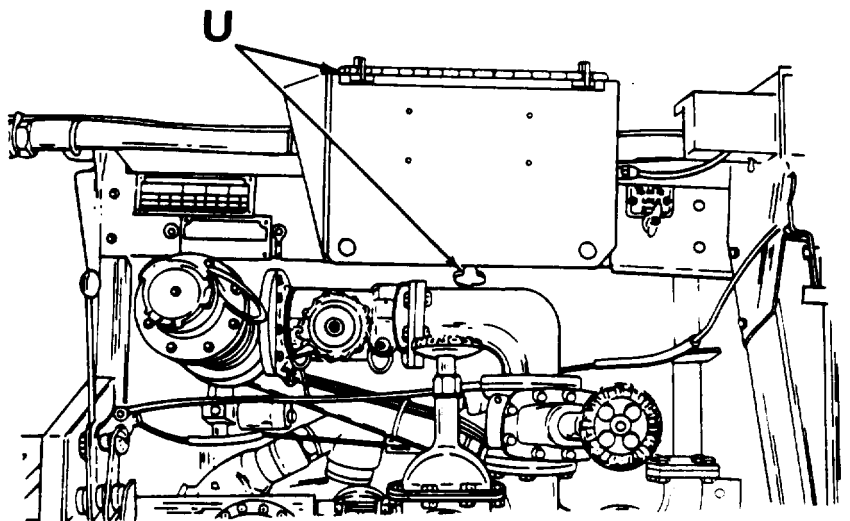

*Figure 3-21. Location of Control Panel Cover Hinge and Latch (M967A1, M969A1, and M970A1).*

TA502294



## Section II. PREVENTIVE MAINTENANCE CHECKS AND SERVICES (PMCS)

### 3-2. Maintenance Forms and Records

Every mission begins and ends with paperwork. There isn't much of it, but you have to keep it up. The forms and records you will fill out have several uses. They are a permanent record of the the services, repairs, and modifications made on your vehicle. They are reports to unit maintenance and to your commander. And they are a checklist for you when you want to know what is wrong with the vehicle after its last use, and whether those faults have been fixed. For the information you need on forms and records, see DA Pam 738-750.

### 3-3. Preventive Maintenance Checks and Services

*a.* Always pay attention to the WARNINGS and CAUTIONs while doing the PMCS checks.

*b.* Do your BEFORE (B) PREVENTIVE MAINTENANCE just before you operate the vehicle.

*c.* Do your DURING (D) checks and services PREVENTIVE MAINTENANCE while the equipment and/or its component systems are in operation.

*d.* Do your AFTER (A) PREVENTIVE MAINTENANCE right after operating the vehicle.

*e.* Do your WEEKLY (W) PREVENTIVE MAINTENANCE once a week.

*f.* Do your MONTHLY (M) PREVENTIVE MAINTENANCE once a month.

*g.* If something doesn't work, troubleshoot it with the instructions in this manual, or notify your supervisor.

*h.* Always do your PREVENTIVE MAINTENANCE CHECKS in the same order so that it gets to be a habit. Once you've had some practice, you'll spot anything wrong in a hurry.

*i.* If anything looks wrong and you can't fix it, write it on your DA Form 2404. If you find something seriously wrong, report it to unit maintenance RIGHT NOW.

*j.* When you do your PREVENTIVE MAINTENANCE, take along the tools you need to make all the checks. You'll always need a rag or two.

**area. Avoid contact with skin, eyes, and clothes, and DO NOT breathe vapors. DO NOT use near open flame or excessive heat. The solvent's flash point is 100°F-138°F (38°C-59°C). If you become dizzy while using cleaning solvent, immediately get fresh air and medical help. If solvent contacts eyes, Immediately wash your eyes with water and get medical aid.**

(1) *Keep It Clean.* Dirt, grease, oil, and debris only get in the way and may cover up a serious problem. Clean as you work and as needed. Use dry cleaning solvent (item 11, Appendix E) on all metal surfaces. Use soap and water when you clean rubber or plastic material.

(2) *Bolts, Nuts, and Screws.* Check them all for obvious looseness, missing, bent, or broken condition. You can't try them all with a tool, of course, but look for chipped paint, bare metal, or rust around bolt heads. If you find one you think is loose, tighten it, or report it to unit maintenance if you can't tighten it.

(3) *Welds.* Look for loose or chipped paint, rust, or gaps where parts are welded together. If you find a bad weld, report it to unit maintenance.

(4) *Electric Wires and Connectors.* Look for cracked or broken insulation, bare wires, and loose or broken connectors. Tighten loose connectors and make sure wires are in good shape.

(5) *Hoses and Fluid Lines.* Look for wear, damage, and leaks, and make sure clamps and fittings are tight. Wet spots show leaks, of course, but a stain around a fitting or connector can also mean a leak. If a leak comes from a loose fitting or connector, tighten it. If something is broken or worn out, report it to unit maintenance.

*k.* You must know how fluid leakage affects the status of your vehicle. The following are definitions of the types/classes of leakage you need to know to be able to determine the status of your vehicle. Learn, then be familiar with them and REMEMBER: WHEN IN DOUBT NOTIFY YOUR SUPERVISOR!

#### *Leakage Definitions for Crew/Operator PMCS*

CLASS I	Seepage of fluid (as indicated by wetness or discoloration) not great enough to form drops.
CLASS II	Leakage of fluid great enough to form drops but not great enough to cause drops to drip from item being checked/inspected.
CLASS III	Leakage of fluid great enough to form drops that fall from the item being checked/inspected.

### **WARNING**

**Dry cleaning solvent P-D-680 is toxic and flammable. Always wear protective goggles and gloves, and use only in a well-ventilated**

**CAUTION**

Equipment operation is allowable with minor leaks (Class I or II). Of course, consideration must be given to the fluid capacity in the item/system being-checked/inspected. When in doubt, notify your supervisor.

*Table 3-1. Operator/Crew Preventive Maintenance Checks and Services.*

ITEM NO.	INTERVAL					ITEM TO BE INSPECTED PROCEDURE Check for and have repaired, filled or adjusted as needed.	Equipment Is Not Ready/Available It
	B	D	A	w	M		
						<p><b>NOTE</b></p> <p><b>Perform weekly as well as before PMCS if:</b></p> <p><b>a. You are the assigned operator but have not operated vehicle since last weekly.</b></p> <p><b>b. You are operating vehicle for the first time.</b></p> <p><b>MAKE THE FOLLOWING WALK AROUND CHECKS:</b></p> <p><b>Exterior of Vehicle.</b></p> <p>a. Check for evidence of fuel leakage on or under semitrailer.</p> <p>b. Check fire extinguishers for proper gage readings and check security of mounting brackets. Red button should be down.</p> <p><b>Tires and Wheels.</b></p> <p>a. Inspect tires for unusual wear or damage.</p> <p>b. Check for proper air pressure. Hard road surfaces – 60 psi. Cross country and sand – 40 psi.</p> <p>c. Inspect wheels for cracks or other damage. Check tightness of wheel nuts.</p> <p><b>Towing Connections.</b></p> <p>a. Inspect bolt-on kingpin or upper coupler (kingpin) plate for damage or loose mounting bolts.</p> <p>b. Visually inspect for obvious cracked or broken welds along upper coupler (kingpin) plate.</p> <p>c. Connect towing vehicle air lines to couplings on semitrailer. With towing vehicle engine running, check air lines and couplings for air leaks.</p> <p>d. Connect towing vehicle electrical line to receptacle on semitrailer. Check all lights for damage. Check that all lights are operating. if not operating, check tightness of connection at receptacle. if tight, have unit maintenance test and repair lights. Check electrical line for damage.</p>	
1							Any fuel leakage is evident.
							Fire extinguisher missing. Red button is up.
2							Tires have damage which could result in tire failure.
							Wheel damaged or wheel nuts missing.
3							Bolt-on kingpin or upper coupler (kingpin) plate damaged, or mounting bolts loose.
							Any welds are cracked or broken.
							Air leaks are evident.
							Turn signal and stop lights not operating. Towing vehicle intervehicular cable is damaged (cuts, cracks, broken wires, etc.).

Table 3-1. Operator/Crew Preventive Maintenance Checks and Services (Con't).

ITEM NO.	INTERVAL					ITEM TO BE INSPECTED PROCEDURE: Check for and have repaired, filled or adjusted as needed.	Equipment Is Not Ready/Available If:
	B	D	A	W	M		
4				•		<p><b>Landing Gear.</b></p> <p>a. Inspect for loose shoes, bent or damaged landing gear legs, and loose or missing mounting bolts.</p> <p>b. After coupling towing vehicle to semitrailer, engage landing gear handle, and raise and lower landing gear legs.</p>	<p>Mounting bolts loose or missing.</p> <p>Landing gear legs cannot be raised or lowered.</p>
5		•	•			<p><b>Piping System.</b></p> <p>a. Inspect all pipes for dents and cracks</p> <p>b. Check all valves and couplings for leaks.</p> <p>c. Check valves for proper operation.</p> <p>d. Drain water from piping system (para 2-13d).</p>	<p>Pipes are damaged to an extent that fuel flow will be restricted. Pipes are cracked allowing fuel leakage.</p> <p>Leaks are evident.</p> <p>Valve is hard to open or close.</p>
6	•	•				<p><b>Hose Troughs.</b></p> <p>a. Inspect troughs for debris. Remove any debris found and check that water drain holes are open.</p> <p>b. Visually inspect hose lock bars for obvious damaged or missing parts.</p>	
7		•	•	•		<p><b>Control Panel.</b></p> <p>a. Check switches for proper operation.</p> <p>b. Check that preheat indicator light is lit when engine is preheating.</p> <p>c. Check gages for proper operation. Gages should read as follows:</p> <ul style="list-style-type: none"> <li>• Voltmeter 12–14V with engine running,</li> <li>• Oil pressure gage 30–40 psi with engine warm and running.</li> <li>• Fuel pressure gage 12–14 psi.</li> <li>• Pump pressure gage:                             <ul style="list-style-type: none"> <li>– 30 psi for 4-inch low-head pump (M967, M967A1, M969, and M969A1).</li> <li>– 65 psi for 3-inch high pressure pump (M970 and M970A1).</li> </ul> </li> </ul> <p>d. Check filter/separator gage.</p>	<p>Switch does not complete its function.</p> <p>Gage is not functioning properly.</p> <p>Pump pressure gage is not functioning properly during retail (pumping) operations.</p> <p>Gage indicates 20 psi or higher.</p>

Table 3-1. Operator/Crew Preventive Maintenance Checks and Services (Con't).

ITEM NO.	INTERVAL					ITEM TO BE INSPECTED PROCEDURE Check for and have repaired, filled or adjusted as needed.	Equipment Is Not Ready/Available If:
	B	D	A	W	M		
8	•					<p><b>Tank.</b></p> <p>a. Inspect tank shell for dents and leaks.</p> <p>b. Check for leaks around fusible vent caps. Tighten caps if loose.</p> <p>c. Check for leaks around manhole cover. If leaks are evident, check for damaged cover gasket, loose mounting ring, and that cover is securely latched.</p>	<p>Tank shell has leaks.</p> <p>Leaks are evident.</p> <p>Manhole cover gasket is damaged.</p>
9		•				<p><b>Catwalk Drains.</b></p> <p>Inspect for clogged drains. Remove foreign matter.</p>	
10		•				<p><b>Emergency Valve and Vent.</b></p> <p>Ensure that all valves are closed. Operate control lever A and ensure that the cable is actuating the emergency valve lever and opens the vent on top of semitrailer.</p>	<p>Control lever A will not actuate emergency valve lever, or vent fails to open.</p>
11		•				<p><b>Emergency Valve Shut-off.</b></p> <p>Ensure that all valves are closed. Move control lever A to the OPEN position. On the front curbside of the semitrailer, pull the emergency valve shut-off control. Observe that control lever A has moved to the CLOSED position.</p>	<p>Control lever A does not move to the CLOSED position.</p>
12		•				<p><b>Cabinet Door Shut-off (M970 and M970A1).</b></p> <p>Ensure that all valves are closed. Open the hose reel cabinet door. Move control lever A to the OPEN position. Close the cabinet door and observe that control lever A moves to the CLOSED position.</p>	<p>Control lever A does not move to the CLOSED position.</p>
13		•				<p><b>Brake System.</b></p> <p>a. With towing vehicle coupled to semitrailer, apply semitrailer brakes and inspect all air lines and fittings for leaks.</p> <p>b. Apply semitrailer brakes and observe operation.</p> <p>c. Drain water from both air reservoirs by opening the air reservoir drain cocks.</p>	<p>Brakes do not stop semitrailer, or semitrailer pulls to one side.</p>
			•				

Table 3-1. Operator/Crew Preventive Maintenance Checks and Services (Con't).

ITEM NO.	INTERVAL					ITEM TO BE INSPECTED PROCEDURE Check for and have repaired, filled or adjusted as needed.	Equipment Is Not Ready/Available If:
	B	D	A	W	M		
14		●				Rear Axles.  During movement of semitrailer, be aware of wander or side pull. Listen for excessive noise. These are indications of improper axle alinement.	Semitrailer wanders, has side pull, or axles have excessive noise.
15					●	Suspension.  a. Visually inspect bogie for obvious damage or leaks.  b. Inspect springs for broken leaves.  c. Visually inspect torque rods and running gear hardware for obvious damage.	Class III leakage.  Loose or missing running gear hardware.
16					●	Batteries.  Remove battery cover. Check electrolyte level in each cell. If low, add distilled water. Check for corrosion. Check for damage.	Battery is damaged.
17					●	Battery Cables and Terminals.  Check for corrosion at terminals. Check cable tightness on terminals. Check for cable damage.	
18	●					Engine Assembly.  a. Drain water from both fuel filters. Loosen, but do not remove drain plug at bottom of filter. Allow fuel to drain until clear of water. Tighten drain plug.  b. Check that red area is not visible in air cleaner dirt indicator. Remove and clean engine air cleaner element, if required. Replace after six cleanings or annually.  c. Listen for excessive engine noise which indicates the muffler or exhaust pipes need replacing.  d. Visually inspect for loose engine cowling or shrouding.  e. Inspect for debris in grille of air cooling intake area.	Engine does not operate if required for mission.  Dirt indicator has red area visible.

Table 3-1. Operator/Crew Preventive Maintenance Checks and Services (Con't).

ITEM NO.	INTERVAL					ITEM TO BE INSPECTED PROCEDURE: Check for and have repaired, filled or adjuated as needed.	Equipment Is Not Ready/Available If:
	B	D	A	W	M		
19		•				Filter/Separator (M969, M969A1, M970, and M970A1).	Fuel is seeping from automatic drain valve.  Relief valve is plugged.
		•				a. Check automatic drain valve on bottom of filter/separator for fuel seepage. No other liquid except water should be detected at the automatic drain valve.  b. Check for debris in relief valve at top of filter/separator (fig. 2-13).	
20				•		Centrifugal Pump.	Pump is leaking,
					•	a. Remove pipe plug and check oil level. Add oil if below bottom of pipe plug hole.  b. Inspect pump for signs of leaks around gasket.	
21		•				Hose Reels (M969, M969A1, M970, and M970A1).	Rewind handle is missing.  Hose reel will not unwind hose.  Cuts or cracks in hoses which allow any detectable leakage.
			•			a. Check that rewind handle is not missing.	
				•		b. When unwinding hoses, observe for binding in the hose reel.  c. Inspect hoses for cuts and cracks.	
22		•				Meter Indicator (M969, M969A1, M970, and M970A1).	
						Check meter for registration of fuel being dispensed.	
23						Precheck Control.	Precheck system does not operate. Control lever does not move freely from closed to open position.
					•	Check operation of shut-off float.	
24						Load/Unload Selector System (M967, M967A1, M969, and M969A1).	Selector system does not operate. Control lever does not move freely from closed to open position.
					•	Check operation of selector control.	

Table 3-1. Operator/Crew Preventive Maintenance Checks and Services (Con't).

ITEM NO.	INTERVAL					ITEM TO BE INSPECTED PROCEDURE: Check for and have repaired, filled or adjusted as needed.	Equipment Is Not Ready/Available If:
	B	D	A	W	M		
25		•				<p><b>Deadman Control (M970 and M970A1).</b></p> <p>a. Unwind deadman control hoses and check for operation of hose reel.</p> <p>b. Inspect for damage to the control and hoses. Check for leaks when operating the control.</p>	<p>Hose will not unwind or binding is noticed in the hose reel when unwinding or rewinding hose.</p> <p>Leaks are evident at connections.</p>
26	•	•				<p><b>Deadman Gage.</b></p> <p>a. Check deadman gage for damage (fig. 2-15).</p> <p>b. Check at what pressure the 3-inch control valve opens. Pressure gage should read 80 psi.</p>	
27					•	<p><b>Nozzles.</b></p> <p>Clean screens.</p>	
28	•					<p><b>Grounding Devices.</b></p> <p>a. Check static reel operation. Inspect for missing grounding clips and loose or missing mounting hardware.</p> <p>b. Check portable grounding rod to ensure that it is not damaged or missing.</p>	<p>Missing or loose hardware.</p> <p>Missing from vehicle or damaged.</p>

**Section III. TROUBLESHOOTING**

**3-4. General**

*a.* This section contains troubleshooting information for locating and correcting the operating troubles that may develop in the semitrailers. Each malfunction for an individual component unit or system is followed by a list of tests or inspections that will help you determine corrective actions to take. You should perform the test/inspections and corrective actions in the order listed in table 3-2.

*b.* This manual cannot list all malfunctions that may occur, nor all tests, inspections, or corrective actions. If a malfunction is not listed or is not corrected by listed corrective actions, notify unit maintenance.

**NOTE**

**Before you use this table, ensure that you have performed all applicable operational preventive maintenance checks.**

*Table 3-2. Operator/Crew Troubleshooting.*

---

MALFUNCTION	TEST OR INSPECTION	CORRECTIVE ACTION
-------------	--------------------	-------------------

---

**ELECTRICAL SYSTEM**

**1. ALL LAMPS DO NOT LIGHT.**

- Step 1. Check light switch in towing vehicle for proper setting.  
Set light switch to correct position.
- Step 2. Check fuse in towing vehicle.  
If fuse is blown, contact unit maintenance.
- Step 3. Check if intervehicular cable is properly plugged into receptacle on semitrailer and towing vehicle.  
Pull cable plug out and reinsert tightly in receptacle.
- Step 4. Check for dirty or corroded contacts in receptacle or on plug of intervehicular cable.
  - a.* Pull cable plugs and check for dirt or corrosion.
  - b.* Clean plugs and receptacle.
  - c.* Reinsert plugs into receptacles.

**2. ONE OR MORE LAMPS (BUT NOT ALL) WILL NOT LIGHT.**

- Step 1. Check for damaged tail or marker light.  
If lights require replacement or repair, notify unit maintenance.
- Step 2. Check for dirty or corroded contacts in receptacle or on plugs of intervehicular cable.
  - a.* Pull cable plugs and check for dirt or corrosion.
  - b.* Clean plugs and receptacle.
  - c.* Reinsert plugs into receptacles.



Table 3-2. Operator/Crew Troubleshooting (Con't).

---

MALFUNCTION	TEST OR INSPECTION	CORRECTIVE ACTION
-------------	--------------------	-------------------

---

### ELECTRICAL SYSTEM (Con't)

#### 3. DIM OR FLICKERING LIGHTS.

Check for dirty or corroded intervehicular cable plugs and receptacles.

Refer to Step 2 under Malfunction 2, *ONE OR MORE LAMPS (BUT NOT ALL) WILL NOT LIGHT.*

---

### BRAKES

#### 4. BRAKES WILL NOT RELEASE.

- Step 1. Check if brake valve on towing vehicle is in applied position.  
                     Move brake valve to the released position.
- Step 2. Check if shut-off valves are closed on towing vehicle.  
                     Open valves.
- Step 3. Check if air hose couplings are improperly connected to semitrailer.  
                     Remove couplings and reconnect properly.
- Step 4. Check for dented or cracked air lines in the Emergency Line.  
                     If lines are damaged, notify unit maintenance.
- Step 5. Check if rear air reservoir tank drain valve is open (fig. 2-2).  
                     If semitrailer is coupled to towing vehicle, close the drain valve.
- Step 6. M970 and M970A1 only. Make sure piping cabinet door is tightly shut.

#### 5. NO BRAKES OR WEAK BRAKES.

- Step 1. Check if shut-off valves are closed on towing vehicle.  
                     Open valves.
- Step 2. Check if air hose couplings are improperly connected to semitrailer.  
                     Remove couplings and reconnect properly.
- Step 3. Check for bent or dented air lines in the Service Line.  
                     If lines are bent or dented, notify unit maintenance.

Table 3-2. Operator/Crew Troubleshooting (Con't).

---

MALFUNCTION	TEST OR INSPECTION	CORRECTIVE ACTION
-------------	--------------------	-------------------

---

**BRAKES (Con't)**

**6. SLOW BRAKE APPLICATION OR SLOW RELEASE.**

Check for bent or dented air lines.

If lines are bent or dented, notify unit maintenance.

**7. GRABBING BRAKES.**

Check for moisture in rear air reservoir.

Drain rear reservoir (fig. 2-2).

---

**TIRES**

**8. EXCESSIVELY WORN, SCUFFED, OR CUPPED.**

Step 1. Check tire pressure.

Inflate to 60 psi for hard surface roads, and 40 psi for cross-country or sand.

Step 2. Check for loose wheels.

Tighten wheel stud nuts.

Step 3. Check for bent wheel.

If bent, notify unit maintenance.

---

**LANDING GEAR**

**9. DIFFICULTY IN TURNING OPERATING CRANK.**

Check if lower leg is bent.

a. If bend is not readily apparent, check to determine whether lower leg will center in various positions.

b. If bent, notify unit maintenance.

Table 3-2. Operator/Crew Troubleshooting (Con't).

MALFUNCTION	TEST OR INSPECTION	CORRECTIVE ACTION
<b>ENGINE</b>		
<b>10. ENGINE WILL NOT TURN OVER.</b>		
Step 1.	Remove battery cover and check for loose battery cable connections (para 3-6).	Tighten loose connections.
Step 2.	Check for discharged or defective battery.	a. Remove cell caps and check for loss of electrolyte. Fill each cell as necessary (para 3-6).
<b>NOTE</b>		
<b>Do not slave start or jump start batteries.</b>		
b. If battery is discharged, notify unit maintenance.		
<b>11. ENGINE HARD TO START OR TURNS OVER SLOWLY.</b>		
Step 1.	Remove battery cover and check for discharged or defective battery.	a. Remove cell caps and check for loss of electrolyte, Fill each cell as necessary (para 3-6).
<b>NOTE</b>		
<b>Do not slave start or jump start batteries.</b>		
b. If battery is discharged, notify unit maintenance.		
Step 2.	Check air cleaner dirt indicator for showing of red band.	If red band is showing, service air cleaner (para 3-1 8).
Step 3.	Check for fuel line leaks.	If connections are loose or lines are damaged, notify unit maintenance.
<b>12. ENGINE TURNS OVER BUT FAILS TO START</b>		
Check level of fuel in fuel tank.		
Add fuel.		

*Table 3-2. Operator/Crew Troubleshooting (Con't).*

---

<b>MALFUNCTION</b>	
<b>TEST OR INSPECTION</b>	
<b>CORRECTIVE ACTION</b>	

---

**ENGINE (Con't)**

**13. ENGINE MISFIRES AT HEAVY LOAD.**

- Step 1. Check air cleaner dirt indicator for showing of red band.  
 If red band is showing, service air cleaner (para 3-1 8).
- Step 2. Check for fuel line leaks.  
 If connections are loose or lines are damaged, notify unit maintenance.

**14. LOWER ENGINE POWER.**

- Step 1. Check air cleaner dirt indicator for showing of red band.  
 If red band is showing, service air cleaner (para 3-1 8).
- Step 2. Check for fuel line leaks.  
 If connections are loose or lines are damaged, notify unit maintenance.

**15. LOW OIL PRESSURE INDICATED ON GAGE (MINIMUM 20 psi).**

- Step 1. Check oil level.  
 Add oil, if necessary.
- Step 2. Check gage for damage.  
 If gage is damaged, notify unit maintenance.
- Step 3. Check for kinked or bent tubing between oil pressure gage and engine.  
 If kinked or bent tubing is found, notify unit maintenance.

---

**FUELING OPERATIONS**

**16. FUEL DOES NOT FLOW DURING ANY NONFILTERED FUELING OPERATION.**

- Step 1. Check if emergency valve is open.  
 Open valve by operating emergency valve control A. If control does not function, notify unit maintenance.
- Step 2. Check that proper valves are open.  
 Refer to Flow Diagram pertaining to fueling operation being performed.

Table 3-2. Operator/Crew Troubleshooting (Con't).

**MALFUNCTION****TEST OR INSPECTION****CORRECTIVE ACTION****FUELING OPERATIONS (Con't)****16. FUEL DOES NOT FLOW DURING ANY NONFILTERED FUELING OPERATION (Con't).**

Step 3. Check for clogged screen in nozzle (paras 3-14,3-15, and 3-16).

Clean or replace screen.

**17. FUEL DOES NOT FLOW DURING ANY FILTERED FUELING OPERATION (M969, M969A1, M970, and M970A1).**

Step 1. Check if emergency valve is open.

Open valve by operating emergency valve control A. If control does not function, notify unit maintenance.

Step 2. Check that proper valves are open.

Refer to Flow Diagram pertaining to fueling operation being performed.

Step 3. Check if there is too much water in filter/separator.

Drain filter/separator sump (para 2-13d).

Step 4. Check reading of filter/separator gage.

A reading above 25 psi indicates fuse replacement is necessary. Notify unit maintenance.

Step 5. Check for improperly connected nozzle or faulty nozzle.

a. If improperly connected, connect nozzle properly.

b. If faulty, notify unit maintenance.

Step 6. Check for clogged screen in nozzle (paras 3-14 through 3-17).

Clean or replace screen.

**18. FUEL DOES NOT FLOW DURING ANY OVERWING FUELING OPERATION (M970 and M970A1).**

Step 1. Complete Steps 1 through 5 under Malfunction 17, *FUEL DOES NOT FLOW DURING ANY FILTERED FUELING OPERATION*.

Step 2. Check if deadman control is deactivated.

a. If 2½-inch hose was used before the 1½-inch hose, depress deadman control S and release it.

b. Depress and hold the deadman release plunger in the hose reel cabinet (fig. 2-15) for 5-10 seconds to deactivate the deadman system.

Table 3-2. Operator/Crew Troubleshooting (Con't),

---

<b>MALFUNCTION</b>	
<b>TEST OR INSPECTION</b>	
<b>CORRECTIVE ACTION</b>	

---

**FUELING OPERATIONS (Con't)**

**18. FUEL DOES NOT FLOW DURING ANY OVERWING FUELING OPERATION (M970 and M970A1) (Con't).**

- Step 3. Check for clogged screen in nozzle (para 3-1 5).  
Clean or replace screen.

**19. FUEL DOES NOT FLOW DURING ANY UNDERWING FUELING OPERATION (M970 and M970A1).**

- Step 1. Complete Steps 1 through 5 under Malfunction 17, *FUEL DOES NOT FLOW DUR/NG ANY FILTERED FUELING OPERATION.*
- Step 2. Check if deadman actuator was not depressed or is inoperable.

**NOTE**

**Connect towing vehicle to build up air pressure. Deadman will not function without outside air source.**

- a. Depress deadman actuator S to resume flow to meter.
- b. Check deadman hoses for kinks, Straighten kinks.
- c. Check deadman hoses for breaks or loose connections. Notify unit maintenance if any are found.

- Step 3. Check for clogged screen in nozzle (para 3-17).  
Clean or replace screen.
- 

**Section IV. MAINTENANCE PROCEDURES**

**3-5. General**

This section provides maintenance instructions for those items which are the responsibility of the operator/crew, The maintenance functions are limited to those operations that are authorized by the Maintenance Allocation Chart (MAC), Appendix B of this manual.

**3-6. Batteries, Terminals, and Cables**

The battery terminals and cables should be inspected for excessive dirt and corrosion, loose connections, and damage each time before the vehicle is put into operation.

Dirt, combined with electrolyte or moisture on top of battery, can result in a continuous battery discharge.

a. *Inspection Steps and Services.*

(1) Remove the two wingnuts and washers (fig. 3-22) that secure the battery cover to the battery hold down bracket. Remove the battery cover.

(2) Inspect battery area for excessive dirt and corrosion. Clean battery area using instructions in *b* below.

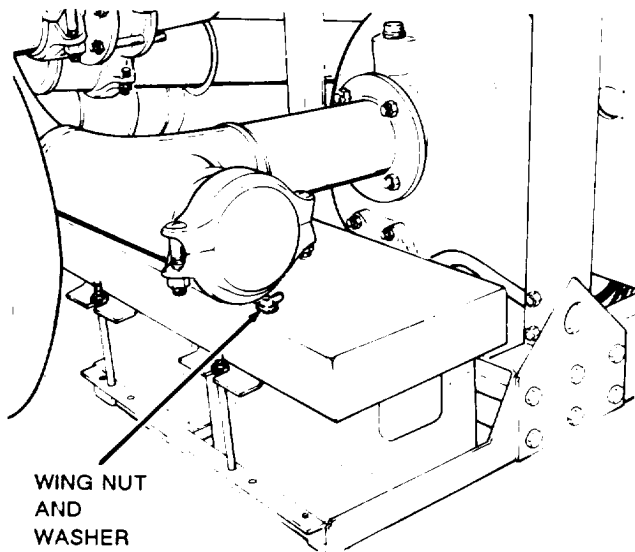

TA099742

**Figure 3-22. Battery With Cover Installed.**

(3) Check cables (fig. 3-23) for frayed insulation. If insulation is worn or frayed, notify unit maintenance.

(4) Check for loose terminals. Tighten if loose.

(5) Remove vent fill covers and check electrolyte level. Electrolyte level must be just below the ring at the bottom of each cell opening. If electrolyte level is low, fill using instructions in paragraph 3-6 *b*.

(6) Install cover with two wingnuts and washers.

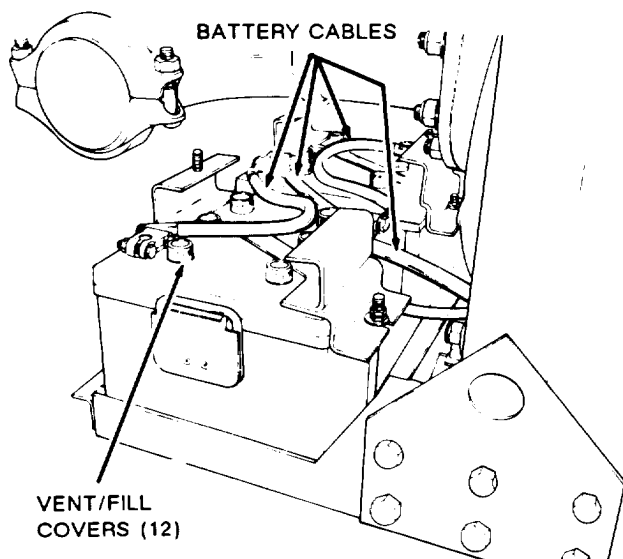

TA099743

**Figure 3-23. Battery With Cover Removed.**

*b. Maintenance Instructions.*

(1) *Cleaning Battery Area.* Use baking soda or ammonia, then flush battery and cables with water.

**NOTE**

Add distilled water only. Do not add electrolyte.

(2) *Filling Battery Cells.* Add distilled water to each cell until the fluid level rises to just below the ring at the bottom of the cell opening. Do not overfill. Too much water can cause poor performance and corrosion around the battery.

**3-7. Air Reservoirs**

*a. Draining Water From Reservoir.* The reservoirs are located beneath the semitrailer in front of the axles (fig. 2-2). Both air reservoirs have a drain cock for removal of water from the tanks. Open each drain cock every day and allow water to flow out. Then, close the drain cocks.

*b. Inspect.* Check that mounting screws holding the reservoirs are tight and that brackets and water drain cocks are not bent or damaged. Notify unit maintenance if any parts need replacing or tightening.

**3-8. Hose Troughs**

*a. Cleaning.* Dirt and water may collect in the hose troughs after a period of time. Remove the hoses from the troughs and remove any debris. Check that water drain holes are open.

*b. Inspect.* Check hose troughs for damage and missing parts. If found, notify unit maintenance.

**3-9. Cabinets and Cabinet Doors**

*a. Piping Assembly.*

(1) *Cleaning.* Remove daily any dirt and debris that may collect in the piping assembly.

(2) *Inspect.* Report any damage to the piping control to unit maintenance.

*b. Hose Reel Cabinet (M969, M969A1, M970, and M970A1).*

(1) *Cleaning.* Remove daily any dirt and debris that may collect in the hose reel cabinet.

(2) *Inspect.* Report any damage to the hose reel cabinet to unit maintenance.

(3) *Lubrication.* Lubricate the cabinet door hinges and latches weekly with engine oil (Section I, Chapter 3).

**3-10. Hose Reels**

a. *Hose Reef Hoses.* After a hose reel hose is unreeled from the hose reel for a fuel servicing operation, visually check the hose for damage. If damage is noticed, notify unit maintenance.

b. *Lubrication.* Lubricate the hose reel side bearings and the hose reel handcrank operation shafts weekly (Section I, Chapter 3).

**3-11. Tool Box**

a. *Cleaning.* Periodically clean tool box of dirt and debris. Make sure drain holes are open.

b. *Inspect.* Inspect tool box cover and tool box for damage. Report any damage to unit maintenance.

**3-12. Filter/Separator Sump**

Drain water from filter/separator after each period of operation (para 2-13 d).

**3-13. Reassembling Breakaway Fitting (M970 and M970A1)**

**NOTE**

Installation of shear pins may be done without removing connector from vehicle.

a. Retract sleeve and remove broken shear pin segments (fig. 3-24).

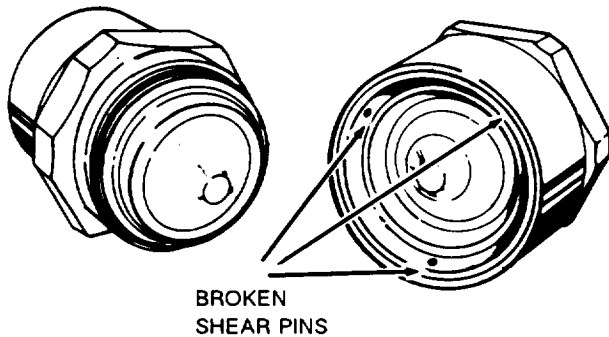

TA099744

**Figure 3-24. Removing Broken Shear Pins in Breakaway Fitting.**

b. Remove three new shear pins from compartment under external O-ring (fig. 3-25).

c. Retract sleeve, push connector halves together and hold. Insert pins in three holes until flush (pins must engage race in mating half). Sleeve will then slide forward and cover pins.

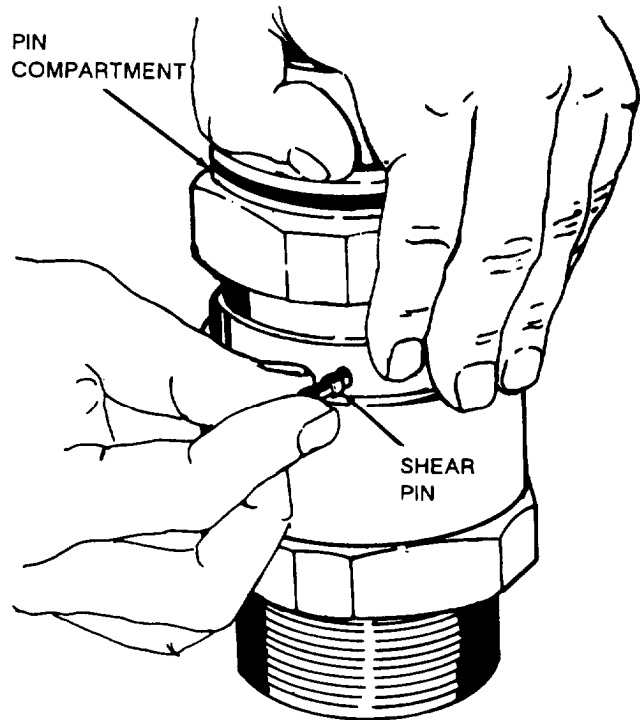

TA099745

**Figure 3-25. Installing New Shear Pins in Breakaway Fitting.**

**3-14. Vehicle Nozzle (M969 and M969A1)**

a. *Service.* The screen in the nozzle (fig. 3-26) must be cleaned periodically and whenever flow is restricted through nozzle.

- (1) Unscrew spout (fig. 3-26) from nozzle.
- (2) Remove screen from within the spout.

**WARNING**

- Dry cleaning solvent P-D-680 is toxic and flammable. Always wear protective goggles and gloves, and use only in a well-ventilated area. Avoid contact with skin, eyes, and clothes, and DO NOT breathe vapors. DO NOT use near open flame or excessive heat. The solvent's flash point is 100°F-138°F (38°C-59°C). If you become dizzy while using cleaning solvent, immediately get fresh air and medical help. If solvent contacts eyes, immediately wash your eyes with water and get medical aid.
- Compressed air used for drying or cleaning purposes must not exceed 30 psi (207 kPa). Wear protective clothing



(goggles and gloves) and use caution to avoid injury to personnel.

(3) Clean the screen in dry cleaning solvent (item 11, Appendix E). Use compressed air to dry screen and to remove any excess material.

(4) Replace screen in spout and then replace spout on nozzle.

b. *Nozzle Replacement.* Should nozzle need replacement, notify unit maintenance.

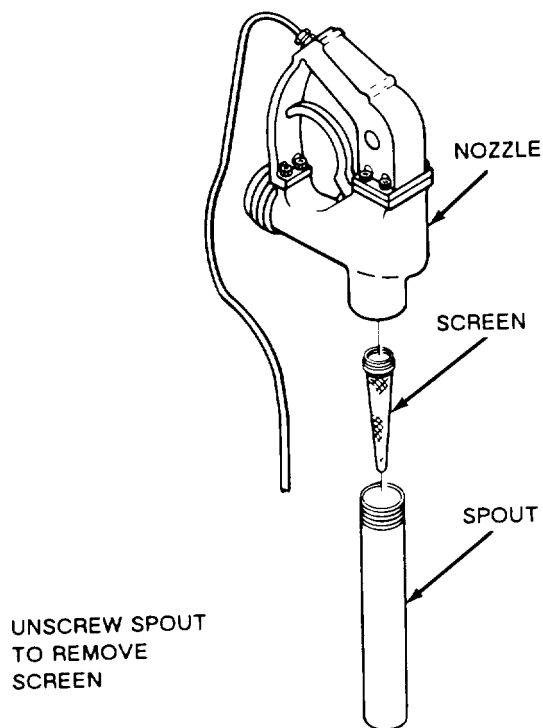

TA502295

**Figure 3-26. Removal of Screen.**

**3-15. Overwing Nozzle (M970 and M970A1)**

a. *Service.* The screen in the nozzle (fig. 3-26) must be cleaned periodically and whenever flow is restricted through nozzle.

- (1) Unscrew spout (fig. 3-26) from nozzle.
- (2) Remove screen from within the spout.

**WARNING**

- Dry cleaning solvent P-D-680 is toxic and flammable. Always wear protective goggles and gloves, and use only in a well-ventilated area. Avoid contact with skin, eyes, and clothes, and DO NOT breathe vapors. DO NOT use near open flame or excessive heat. The solvent's flash point is 100°F-138°F (38°C-59°C). If you become dizzy while using cleaning solvent, immediately get fresh air and medical help. If solvent contacts eyes, immediately wash your eyes with water and get medical aid.
- Compressed air used for drying or cleaning purposes must not exceed 30 psi (207 kPa). Wear protective clothing (goggles and gloves) and use caution to avoid injury to personnel.

(3) Clean the screen in dry cleaning solvent (item 11, Appendix E). Use compressed air to dry screen and to remove any excess material.

(4) Replace screen in spout and then replace spout on nozzle.

b. *Removal.*

- (1) Move ring (fig. 3-27) on coupler back toward
- (2) Pull nozzle from hose.

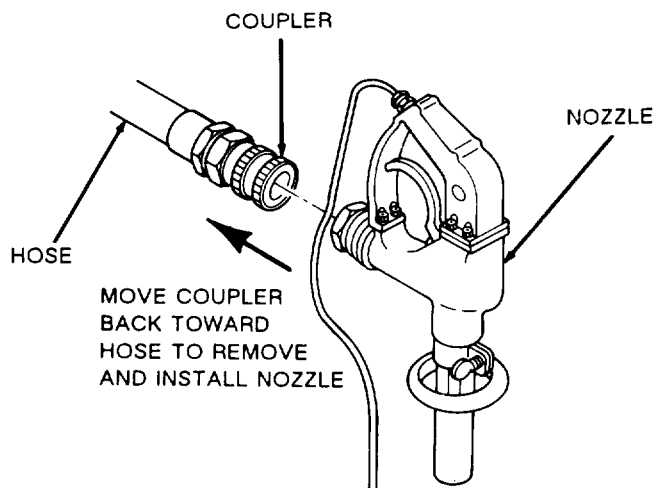

TA502296

**Figure 3-27. Removal of Overwing Nozzle.**

c. *Installation.*

- (1) Move ring (fig. 3-27) on coupler back toward hose.
- (2) Install nozzle into coupler and release ring.
- (3) Check for proper connection by trying to pull the nozzle by hand from the hose.

**3-16. Closed-Circuit Nozzle (M970 and M970A1)**

a. *Service.* The screen in the nozzle must be cleaned periodically and whenever flow is restricted through nozzle.

- (1) Remove nozzle (para 3-16).
- (2) Locate screen (fig. 3-28) in inlet of nozzle and unscrew screen from nozzle.

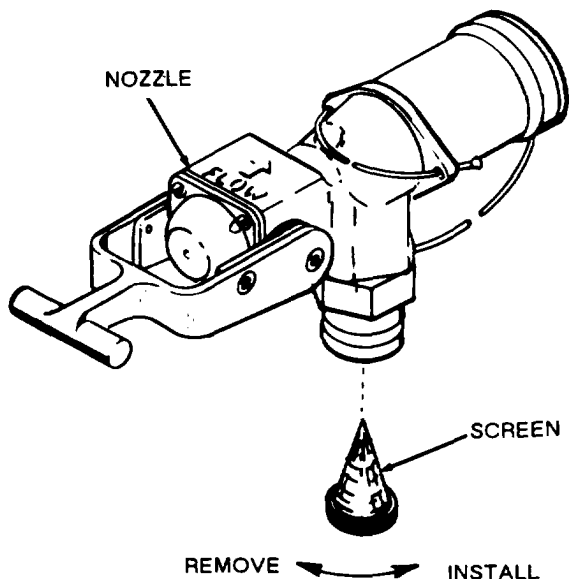

TA099748

**Figure 3-28. Removal of Screen From Closed-Circuit Nozzle.**

**WARNING**

- Dry cleaning solvent P-D-680 is toxic and flammable. Always wear protective goggles and gloves, and use only in a well-ventilated area. Avoid contact with skin, eyes, and clothes, and DO NOT breathe vapors. DO NOT use near open flame or excessive heat. The solvent's flash point is 100°F-138°F (38°C-59°C). If you be-

come dizzy while using cleaning solvent, immediately get fresh air and medical help. If solvent contacts eyes, immediately wash your eyes with water and get medical aid.

- Compressed air used for drying or cleaning purposes must not exceed 30 psi (207 kPa). Wear protective clothing (goggles and gloves) and use caution to avoid injury to personnel.

(3) Clean screen in dry cleaning solvent (item 11, Appendix E). Use compressed air to remove any excess material and to dry the screen.

b. *Removal.*

- (1) Move ring (fig. 3-29) on coupler back toward hose.
- (2) Pull nozzle from hose.

c. *Installation.*

- (1) Move ring (fig. 3-29) on coupler back toward hose.
- (2) Install nozzle into coupler and release ring.
- (3) Check for proper connection by trying to pull, by hand, the nozzle from the hose.

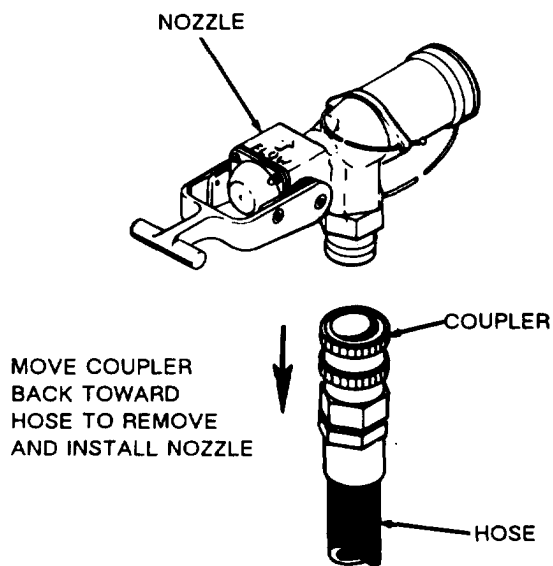

TA099749

**Figure 3-29. Removal of Closed-Circuit Nozzle.**

**3-17. Underwing Nozzle (M970 and M970A1)**

a. Service. The screen in the nozzle must be cleaned periodically and whenever flow is restricted through the nozzle.

(1) Remove nozzle (see *b* below).

(2) Unscrew adapter (fig. 3-30) from nozzle and remove screen.

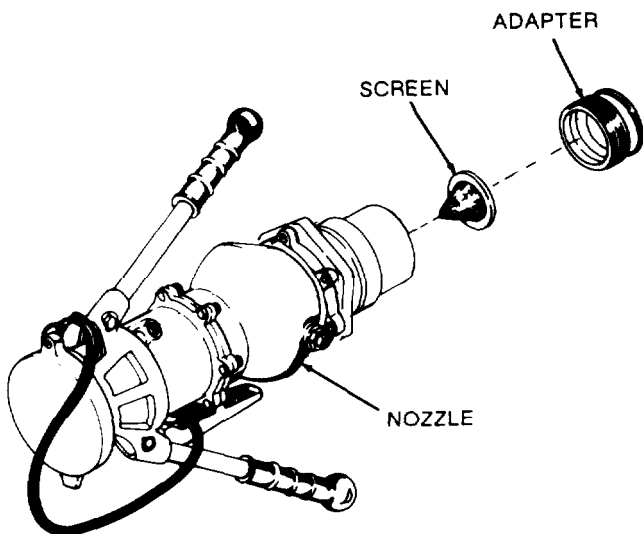

TA099750

**Figure 3-30. Removal of Screen From Underwing Nozzle.**

**WARNING**

- Dry cleaning solvent P-D-680 is toxic and flammable. Always wear protective goggles and gloves, and use only in a well-ventilated area. Avoid contact with skin, eyes, and clothes, and DO NOT breathe vapors. DO NOT use near open flame or excessive heat. The solvent's flash point is 100°F-138°F (38°C-59°C). If you become dizzy while using cleaning solvent, immediately get fresh air and medical help. If solvent contacts eyes, immediately wash your eyes with water and get medical aid.
- Compressed air used for drying or cleaning purposes must not exceed 30 psi (207 kPa). Wear protective clothing (goggles and gloves) and use caution to avoid injury to personnel.

(3) Clean the screen in dry cleaning solvent (item 11, Appendix E). Use compressed air to remove any excess material and to dry the screen.

b. Removal.

(1) Move red sleeve (fig. 3-31) on coupling toward nozzle. Then move red and silver sleeves (fig. 3-31) back toward hose.

(2) Remove nozzle from coupling.

c. Installation.

(1) Install nozzle into coupler.

(2) Move silver sleeve (fig. 3-31) on coupling toward nozzle.

(3) Check for proper connection by trying to pull the nozzle by hand from the hose.

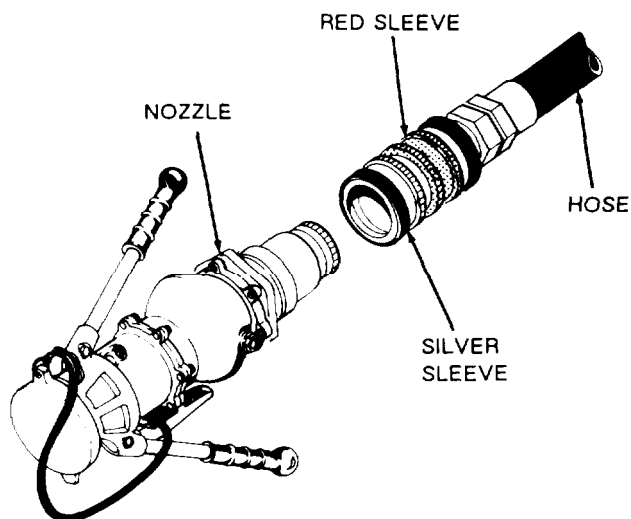

TA099751

**Figure 3-31. Removal of Underwing Nozzle (M970 and M970A1).**

**3-18. Servicing Air Cleaner (fig. 3-32)**

**CAUTION**

Do not run engine if red band is showing in restriction indicator. Damage to engine could result.

a. Service air cleaner whenever the restriction indicator (fig. 3-32) shows a red band.

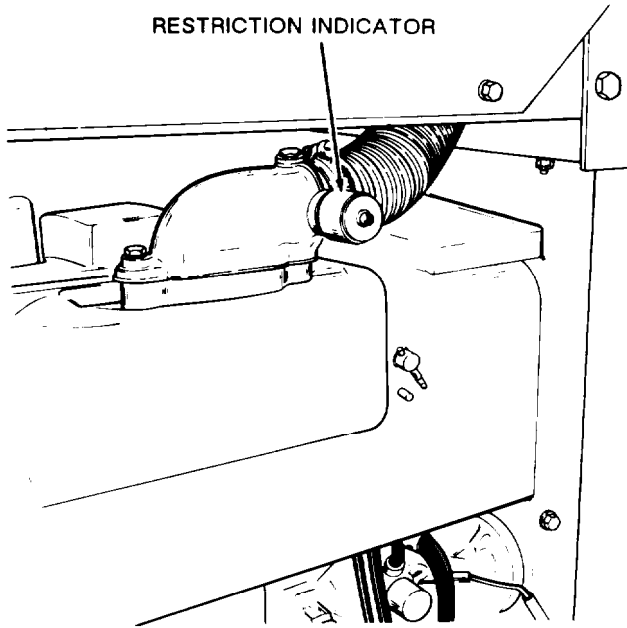

TA099752

Figure 3-32. Engine Air Cleaner Restriction Indicator.

b. To service the filter, loosen clamp (fig. 3-33) and remove end cap.

**CAUTION**

Never run engine with filter or dust collector removed. Damage to engine could result.

c. Unscrew the wingnut and washer and remove the element.

d. Remove baffle from end cap and remove any accumulated dirt.

e. Use a clean rag to wipe clean the interior of air cleaner and end cap.

**WARNING**

Compressed air used for drying or cleaning purposes must not exceed 30 psi (207 kpa).

Wear protective clothing (goggles and gloves) and use caution to avoid injury to personnel.

f. Remove the rain cap and clean with compressed air.

g. Replace baffle in end cap.

h. Clean filter element. After six cleanings or annually, have unit maintenance obtain a replacement filter element.

i. Install new or cleaned filter element in air cleaner body. Fasten in place with washer and wingnut.

j. Replace filter end cap. Ensure that the portion of the end cap marked TOP is at the top. Secure end cap by tightening clamp.

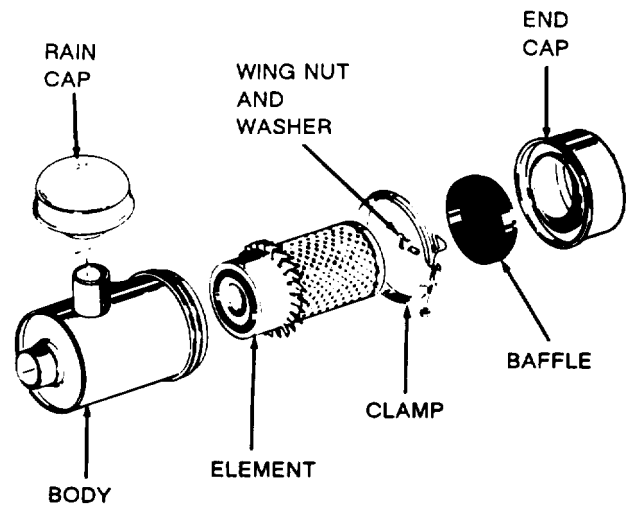

TA502286

Figure 3-33. Exploded View of Air Cleaner.

## CHAPTER 4 UNIT MAINTENANCE INSTRUCTIONS

### Section I. SERVICE UPON RECEIPT OF MATERIAL

#### 4-1. Inspecting and Servicing the Equipment

*a. General.* When material is received by the using organization, it is the responsibility of the officer in charge to determine whether the material has been properly prepared for service by the supplying organization and to be sure it is in condition to perform its function. Whenever practical, the operator/crew will assist unit maintenance personnel in the performance of these services. Semites to be performed are listed below.

#### WARNING

**Dry cleaning solvent P-D-680 is toxic and flammable. Always wear protective goggles and gloves, and use only in a well-ventilated area. Avoid contact with skin, eyes, and clothes, and DO NOT breathe vapors. DO NOT use near open flame or excessive heat. The solvent's flash point is 100°F-138°F (38°C-59°C). If you become dizzy while using cleaning solvent, immediately get fresh air and medical help. If solvent contacts eyes, immediately wash your eyes with water and get medical aid.**

*b. Servicing.* If exterior surfaces are coated with rust-preventive compound, remove with dry cleaning solvent (item 11, Appendix E). Read "Processing and Reprocessing Record for Shipment, Storage and Issue of Vehicles and Spare Engines" tag (DD Form 1397) and follow all directions carefully (para c).

*c. Specific Procedures.*

(1) Open all water drain valves (figs. 2-24 and 2-25) to remove preservative.

(2) Depreservation following DD Form 1397:

(a) Place containers under all drain valves. Open all drain valves to remove the preservative liquid. Open manhole cover to let the tank "air out". A centrifugal or similar type of air blower can be used to speed up the process. About one-half hour without a blower or ten minutes with a blower will be adequate.

#### WARNING

**DO NOT climb into tank unless interior of tank has been drained and purged and an explosive meter check indicates that it is safe to do so. Adequate forced air ventilation or self-contained breathing apparatus must be used. Person entering tank must have an attached lifeline. An observer must be stationed at the manhole opening so that assistance may be summoned in the event of an emergency. Failure to follow this warning may result in serious injury or death to personnel.**

#### CAUTION

**Do not use abrasive powder, steel wool, or other material that will scratch the inside surfaces of the tank.**

(b) Make sure another person is standing by before you climb into the tank through the manhole to inspect for cleanliness. All sediment and debris must be removed using a lint-free cloth (item 24, Appendix E).

(c) Remove all bands and anti-theft bolts and nuts from the hose troughs and fire extinguishers.

(d) Remove all tape from exhaust and intake ports of the engine.

(e) Place a suitable container under engine fuel tank and remove drain plug. When engine fuel tank is empty, replace the drain plug and fill tank with the proper grade of fuel.

(f) Check level of oil (fig. 3-1 through 3-6) in the crankcase. If low, add proper grade oil to bring it up to the "Full" mark on the dipstick.

(g) Remove filters from the filter/separator (para 4-83) and replace gasket and access cover. Put about 200 gallons of the type of fuel to be hauled into the semitrailer tank. Start the engine and pump fuel through the piping. Discharge about 60 gallons of fuel into suitable containers through each hose reel (M969, M969A1, M970, and M970A1). Discharge remaining fuel through the 4-inch hose(s) into suitable containers. Stop engine. Open all drain valves and drain residual fuel into containers. Dispose of fuel in accordance with local SOP.

(h) Remove cover and gasket from the filter/separator and install filters (para 4-83). Replace gasket and cover.

(i) Remove and clean automatic drain valve.

(3) Lubricate all points illustrated in lubrication chart (fig. 3-1 through 3-6), regardless of interval.

(4) Couple an authorized prime mover (para 1-10) to semitrailer. Perform a "break-in" by driving 25-30 miles at speeds up to 30 miles per hour. Check the following:

(a) While in motion, apply service brakes to ensure that brakes are working properly.

(b) Inspect marker lights, stop and turn signal lights, blackout lights, and the control panel lights. Replace if faulty.

(5) All deficiencies which appear to involve unsatisfactory design shall be reported on DA Form 2407 (DA Pam 738-750).

d. *Correction of Deficiencies.* Deficiencies disclosed during preliminary inspection and servicing or during the "break-in" period shall be corrected by using organization or supporting maintenance activity. Deficiencies shall be reported in accordance with DA Pam 738-750.

**Section II. REPAIR PARTS, SPECIAL TOOLS, AND EQUIPMENT**

**4-2. Special Tools and Equipment**

Special tools and equipment required for unit maintenance of the semitrailers are listed in TM 9-2330-356-24P. General mechanics tool sets and common tool sets required for maintenance are authorized by the Table of Allowance (TA) and the Table of Organization and Equipment WOE).

**4-3. Repair Parts**

Repair parts authorized for use by unit maintenance are listed and illustrated in TM 9-2330-356-24P.

**4-4. Fabricated Tools and Equipment**

Table 4-1 contains fabrication instructions for all tools which must be fabricated by unit maintenance personnel for maintenance of this unit. Tables 4-2 through 4-7 list bulk material and dimensions for fabrication of specific electrical leads, harnesses and cables, tubes, conduits, and chains.

*Table 4-1. Fabricated Tools and Equipment.*

Nomenclature	Reference No. or NSN	Material Required
Pressure gage	NSN 6685-00387-9854	1 EA
Gladhand	MS35746-1	2 EA
Valve	11668037	1 EA
Tee	CPCXI, 120280	1 EA
Nipple	MS51846-42	3 EA
Bushing	MS51847-4	2 EA

**Fabrication Instructions:**

Assemble parts to create gladhand connector as shown

**Table 4-1. Fabricated Tools and Equipment (Con't).**

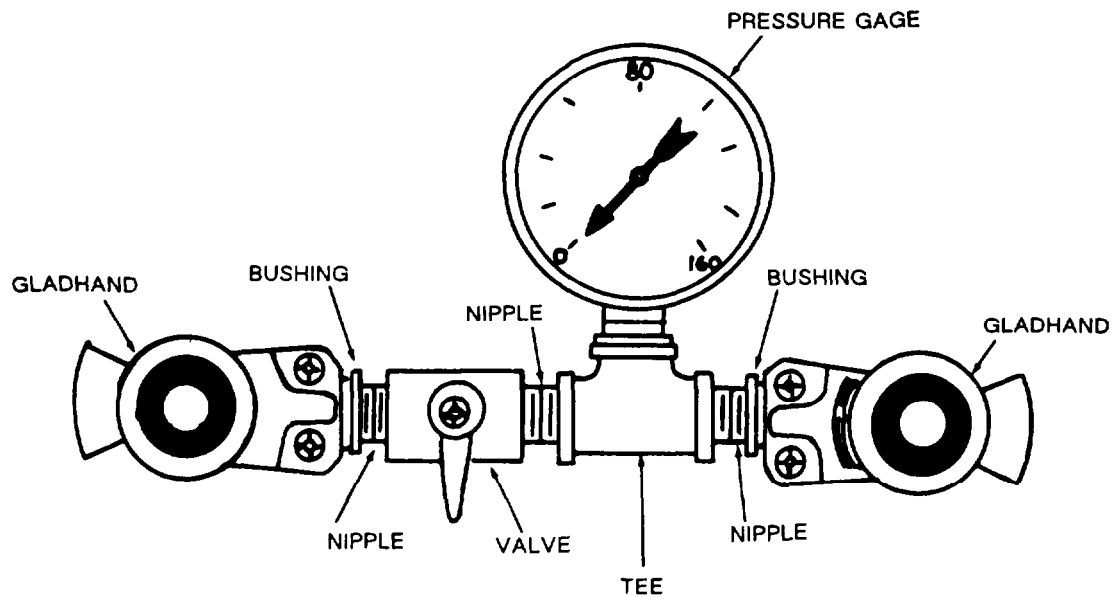

TA502370

Nomenclature	Reference No. or NSN	Material Required
Grease plate		No. 10 gage hot rolled steel

Fabrication Instructions:  
Fabricate to dimensions shown below.

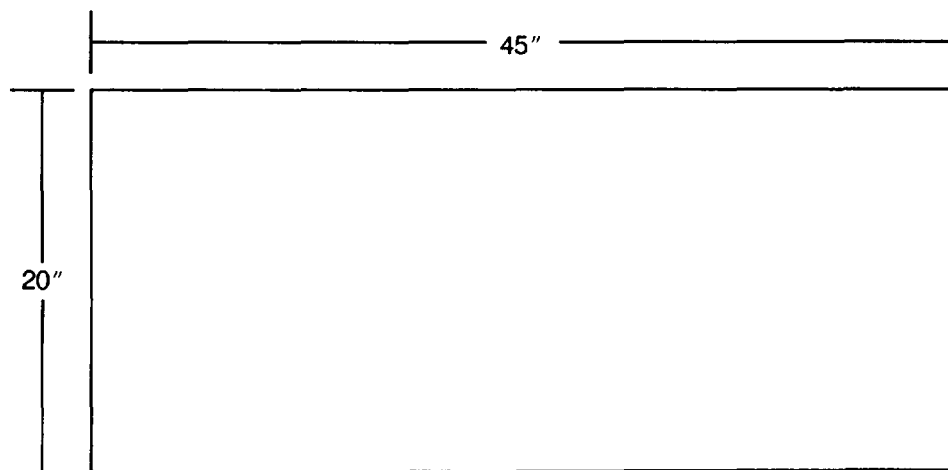

Table 4-2. Fabricated Electrical Leads, Harnesses, and Cables.

Part No.	Bulk Cable		Part No.	Bulk Cable	
	Part No.	Length		Part No.	Length
7056675-9	M13486/1-12	9"	12275202-1	M13486/1-5	122"
7056675-24	M13486/1-12	24"	12275203-1	M13486/1-5	114"
7056675-32	M13486/1-12	32"	12275204-1	M13486/1-5	9"
7056675-60	M13486/1-12	60"	12275205-1	M13486/1-5	9"
7056675-105	M13486/1-12	105"	12275206-1	M13486/1-5	146"
7056675-120	M13486/1-12	120"	12275207-1	M13486/1-5	26"
7720853-16	M13486/1-5	16"	12275208-1	M13486/1-5	9"
7720853	M13486/1-5	24"	12275212-1-1	M13486/1-5	32"
7720853-24	M13486/1-5	24"	12275212-2-1	M13486/1-12	38"
7720853-24	M13486/1-5	24"	12275213-1-1	M13486/1-12	10"
7720853-32	M13486/1-5	32"	12275213-2-1	M13486/1-12	50"
7720853-32	M13486/1-5	32"	12275214-1	M13486/1-5	42"
7720853-36	M13486/1-5	36"	12275215-1	M13486/1-5	33"
7720853-60	M13486/1-5	60"	12275216-1	M13486/1-5	43"
7720853-60	M13486/1-5	60"	12275217-2-1	M13486/1-5	53"
11685923-1-1	M13486/1-5	6"	12275227	M13486/1-5	6"
11685924-1	M13486/1-5	7"	12275229-1	M13486/1-12	6"
11685927-1	M13486/1-5	22"	12275232-1	M13486/1-5	28"
12275201-1	M13486/1-5	468"			

Table 4-3. Fabricated Tube Lines.

Part No.	Bulk Tubing			Part No.	Bulk Tubing		
	Part No.	Dia.	Length		Part No.	Dia.	Length
11670904-3	CPR104420-2	3/8"	72"	12275283-6	CPR104420-2	3/8"	66"
11670904-4	CPR104420-2	3/8"	24"	12275283-7	CPR104420-1	1/4"	28"
11670904-5	CPR104420-2	3/8"	38"	12275283-8	CPR104420-1	1/2"	16"
11670904-6	CPR104420-2	3/8"	61"	12275287-1	CPR104420-2	3/8"	98"
11670904-7	CPR104420-2	3/8"	8"	12275287-2	CPR104420-2	3/8"	66"
11670918-1	CPR104420-2	3/8"	60"	12275287-3	CPR104420-2	1/2"	16"
11670918-2	CPR104420-3	1/2"	60"	12275287-4	CPR104420-2	1/2"	66"
11670918-3	8360440	3/4"	40"	12275287-5	CPR104420-1	1/4"	28"
11670962-1	CPR104420-4	5/8"	28"	12275287-6	CPR104420-2	1/2"	16"
11670962-2	CPR104420-4	5/8"	6"	12275288-1	CPR104420-1	1/4"	30"
11670962-3	CPR104420-4	5/8"	22"	12275288-2	CPR104420-2	3/8"	96"
11685827-1	CPR104420-4	5/8"	28"	12275288-3	CPR104420-2	3/8"	118"
11686008-1	12275547		24"	12275288-4	CPR104420-2	3/8"	48"
11686008-4	12275547		20"	12275288-5	CPR104420-2	3/8"	33"
11686008-5	CPR104420-2	3/8"	50"	12275288-6	CPR104420-2	3/8"	18"
11686008-6	CPR104420-2	3/8"	24"	12275288-7	CPR104420-2	3/8"	72"
11686008-7	CPR104420-2	3/8"	12"	12275493-3	CPR104420-2	3/8"	72"
12275265-1	CPR104420-2	3/8"	42"	12275493-4	CPR104420-2	3/8"	24"
12275265-2	CPR104420-2	3/8"	175"	12275493-5	CPR104420-2	3/8"	38"
12275265-3	CPR104420-2	3/8"	230"	12275493-6	CPR104420-2	3/8"	61"
12275283-3	CPR104420-2	3/8"	96"	12275493-7	CPR104420-2	3/8"	8"
12275283-4	CPR104420-2	3/8"	66"	12275493-8	CPR104420-2	3/8"	284"
12275283-5	CPR104420-4	5/8"	96"				



Table 4-4. Fabricated Chains.

Part No.	Bulk Chain Part No. and Description	Length
8750005-1	C43974	66"
12267056-1	RRC271TY2CL7-16	9"
12275308-1	RRC271TY2CL7-16	14"
12275308-2	RRC271TY2CL7-16	6.66"
12275516-2	RRC271TY2CL7-16	6.6"

Table 4-5. Fabricated Conduit.

Part No.	Bulk Conduit		Type
	Part No.	Length	
1185827-2	CPR104420-4	6"	Flexible
11685827-1	CPR104420-4	28"	Flexible
11685827-3	CPR104420-4	22"	Flexible
11685930-1	12275547	10"	Flexible
11685930-2	12275547	12"	Flexible
11685930-3	12275547	48"	Flexible
11686008-2	12275547	7"	Flexible
11686008-3	12275547	48"	Flexible
11686008-4	12275547	20"	Flexible
12275265-1	CPR104420	42"	Flexible
12275265-2	CPR104420	175"	Flexible
12275265-3	CPR104420-2	230"	Flexible
12275265-4	27-W-924	62"	Flexible

Table 4-6. Fabricated Webbing.

Part No.	Bulk Webbing	Length
12275265-4	27-W-924	62"
12275516-1	27-W-924	8"

Table 4-7. Fabricated Steel Cable.

Part No.	Bulk Cable No.	Length
11670920-1	8360373	168"
11670920-2	8360373	120"
12267077-1	8360373	80"
12267083-1	8360373	75"

**Section III. PREVENTIVE MAINTENANCE CHECKS AND SERVICES (PMCS)**

**4-5. General**

Preventive maintenance is detecting/correcting problems before they happen, or fixing little problems before they become big problems. Table 4-8 contains a list of preventive maintenance checks and services to be performed by unit maintenance personnel. Attention to

these checks and services will increase the useful life of the equipment, but every possible problem cannot be covered in the PMCS. You need to be alert for anything that might cause a problem. If anything does look wrong, and you can't fix it, write it on DA Form 2404 and report it to your supervisor. Be sure to record any corrective action.

a. Perform the checks and services at the intervals shown in table 4-8.

(1) Do your QUARTERLY (Q) PREVENTIVE MAINTENANCE once each three months.

(2) Do your SEMIANNUAL (S) PREVENTIVE MAINTENANCE twice a year, or each six months.

(3) Do your ANNUAL (A) PREVENTIVE MAINTENANCE once each year.

(4) Do your BIENNIAL (B) PREVENTIVE MAINTENANCE once each two years.

(5) Do your HOURS (H) PREVENTIVE MAINTENANCE at the hour interval listed.

b. Ensure that all safety precautions listed in the Warning Summary are followed while performing PMCS. Pay close attention to all WARNINGS and CAUTIONS.

c. If the semitrailer doesn't work properly and you can't see what is wrong, refer to Section IV for troubleshooting instructions.

**WARNING**

**Dry cleaning solvent P-D-680 is toxic and flammable. Always wear protective goggles and gloves, and use only in a well-ventilated area. Avoid contact with skin, eyes, and clothes, and DO NOT breathe vapors. DO NOT use near open flame or excessive heat. The solvent's flash point is 100°F-138°F (38°C-59°C). if you become dizzy while using cleaning solvent, immediately get fresh air and medical help. if solvent contacts eyes, immediately wash your eyes with water and get medical aid.**

d. Make cleanup a part of your preventive maintenance. Dirt, grease, oil, and debris may cover up a serious problem. Use dry cleaning solvent (item 11, Appendix E) to clean metal surfaces. Wipe off excess grease and spilled oil. Use soap and water when you clean rubber or plastic material.

e. Watch for and correct anything that might cause a problem with the equipment. Some things you should watch for are:

(1) Bolts, nuts, and screws that are loose, missing, bent, or broken.

(2) Welds that are poor or broken.

(3) Electrical wires and connectors that are bare, broken, or loose.

(4) Hoses and fluid lines that leak, or show signs of damage or wear.

f. You should know how fluid leaks affect the status of your equipment. Learn and be familiar with the following types/classes of leakage. When in doubt, notify your supervisor!

*Leakage Definitions for PMCS:*

CLASS I Seepage of fluid (as indicated by wetness or discoloration) not great enough to form drops.

CLASS II Leakage of fluid great enough to form drops but not great enough to cause drops to drip from the item being checked/inspected.

CLASS III Leakage of fluid great enough to form drops that fall from the item being checked/inspected.

**CAUTION**

**Equipment operation is allowable with minor leakage (Class I or II). Of course, consideration must be given to the fluid capacity in the item/system being checked/inspected. When in doubt, notify your supervisor.**

g. When operating with Class I or II leaks, continue to check fluid levels as required in your PMCS.

h. Class III leaks should be corrected before releasing equipment for operation.

Table 4-8. Unit Preventive Maintenance Checks and Services.

ITEM NO.	INTERVAL					ITEM TO BE INSPECTED PROCEDURE: Check for and have repaired, filled or adjusted as needed.
	Q	S	A	B	H	
						<p><b>NOTE</b></p> <p>Perform operator/crew PMCS prior to or in conjunction with unit PMCS if:</p> <p>a. There is a delay between dally operation of semitrailer and unit PMCS.</p> <p>b. Regular operator is not assisting/participating.</p>
1	•					<p><b>Tank.</b></p> <p>Check tank for rust at intersections where brackets are welded to tank. Check condition of paint. Notify direct support maintenance of any damage found.</p>
2	•					<p><b>Electrical System.</b></p> <p>a. Check chassis electrical harness connections for security and condition. Check harness for worn or frayed insulation.</p> <p>b. Inspect intervehicular cable receptacle for damage or corrosion.</p>
3	•					<p><b>Bogie Assembly.</b></p> <p>a. Tighten loose cross tube bolts.</p> <p>b. Check spring leaves, clips, and spring U-bolts.</p> <p>c. Check torque rods for looseness.</p>
4			•			<p><b>Towing Connections.</b></p> <p>Inspect condition of kingpin. Bolt-on kingpin or upper coupler (kingpin) plate should be replaced when any of the following conditions exist:</p> <p>a. Wear of <math>\frac{1}{16}</math>-inch over <math>\frac{1}{4}</math> of the circumference of the kingpin. This would be a condition of uneven wear on one or more sides of the kingpin wear surface.</p> <p>b. Even wear over the kingpin surface causing the diameter to be reduced by <math>\frac{1}{16}</math>-inch.</p> <p>c. When a crack of any size is noted anywhere on the pin or associated welds.</p> <p>d. When a nick, chip, or gouge deeper than <math>\frac{1}{8}</math>-inch is noted anywhere on the wear surface of the pin.</p>

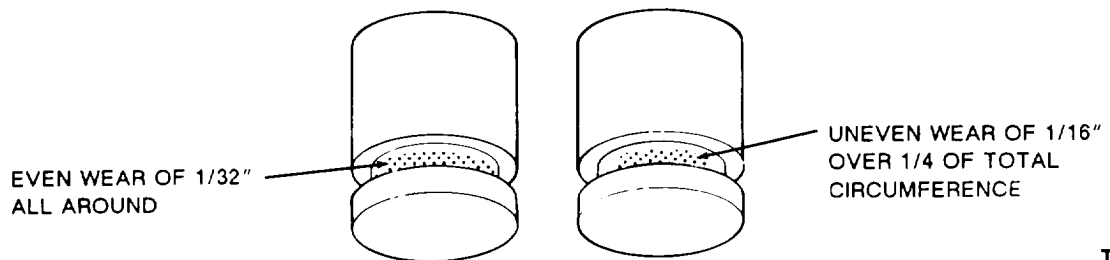

TA502371

Table 4-8. Unit Preventive Maintenance Checks and Services (Con't).

ITEM NO.	INTERVAL					ITEM TO BE INSPECTED PROCEDURE: Check for and have repaired, filled or adjusted as needed.
	Q	S	A	B	H	
5		•				<p><b>Brakes.</b></p> <p>a. Check brake shoe lining thickness. Replace if lining is within .030-inch of rivet heads. Check drum for overheating.</p> <p>b. Check air line couplings for leaks. Tighten if loose. Check coupling packing ring for damage. Replace if damaged.</p>
6			•			<p><b>Wheels and Hubs.</b></p> <p>a. Check for cracked wheels or hubs and missing or loose wheel nuts.</p> <p>b. Disassemble hub and drum. Clean and repack wheel bearings.</p>
7	•					<p><b>Landing Gear.</b></p> <p>Check condition and operation of landing gear. Inspect for damage or wear. Replace damaged parts.</p>
8	•	•				<p><b>Batteries and Cables.</b></p> <p>a. Check electrolyte specific gravity.</p> <p>b. Check for damaged battery cables and terminals. Replace cables or battery if damaged.</p>
9					<p>100</p> <p>100</p> <p>600</p> <p>3000</p> <p>200</p>	<p><b>Engine.</b></p> <p>a. Clean governor linkage.</p> <p>b. Change crankcase oil.</p> <p>c. Change primary fuel filter.</p> <p>d. Change secondary fuel filter.</p> <p>e. Replace oil filter.</p>
10	•					<p><b>Piping.</b></p> <p>Clean piping strainer.</p>
11	•					<p><b>Fire Extinguishers.</b></p> <p style="text-align: center;"><u>WARNING</u></p> <p>Handle charged fire extinguisher cylinders with care. DO NOT jar or expose to temperature above 140°F (60°C).</p> <p style="text-align: center;">NOTE</p> <p>Refer to TB 5-4200-200-10 for guidance on fire extinguisher servicing.</p> <p>a. Remove fire extinguisher from mounting bracket and weight. Fill out maintenance request (DA Form 2407) or exchange request (DA Form 2407) for cylinders requiring recharging.</p>

**Table 4-8. Unit Preventive Maintenance Checks and Services (Con't).**

ITEM NO.	INTERVAL					ITEM TO BE INSPECTED PROCEDURE: Check for and have repaired, filled or adjusted as needed.
	Q	S	A	B	H	
11	• • • • • •					<p><b>Fire Extinguishers (Con't).</b></p> <p><i>b.</i> Check mounting bracket for secure attachment to semitrailer. Check that lockup handle moves freely and is not damaged.</p> <p><i>c.</i> Check that plastic indicator on top of fire extinguisher is intact.</p> <p style="text-align: center;"><b>NOTE</b></p> <p><b>Some fire extinguishers have a safety wire-lead or plastic seal attached to pull pin.</b></p> <p><i>d.</i> Check that safety wire-lead or plastic seal is not broken or missing.</p> <p><i>e.</i> Check that tube is not kinked and nozzle is free of obstructions.</p> <p><i>f.</i> Check that the fire extinguisher tag is securely attached. Check for date of last inspection/recharge.</p> <p><i>g.</i> Cover and install fire extinguisher on mounting bracket. Ensure that lockup handle holds fire extinguisher securely to mounting bracket.</p>

**Section IV. UNIT TROUBLESHOOTING**

**4-6. General**

*a.* This section contains troubleshooting information for locating and correcting most of the operating problems that may develop in the semitrailer. Each malfunction for a particular unit or component is followed by a list of tests or inspections that will help you to determine the probable causes and corrections to be made. Perform the tests and inspections in the order listed in table 4-9.

*b.* Ensure that all safety precautions listed in the Warning Summary are followed while performing PMCS. Pay close attention to all WARNINGS and CAUTIONS.

*c.* This manual cannot list all malfunctions that may occur, nor all tests or inspections and corrective actions. If a malfunction is not listed, or the corrective action does not ease the problem, notify your supervisor.

**NOTE**

**Before you use this table, be sure you have performed all applicable operational preventive maintenance checks.**

*d.* The table lists the common malfunctions that you may find during the operation and maintenance of the semitrailer or its components. You should perform the tests/inspections and corrective action in the order listed.

*Table 4-9. Unit Troubleshooting.*

---

**MALFUNCTION**

**TEST OR INSPECTION**

**CORRECTIVE ACTION**

---

**ELECTRICAL SYSTEM**

**1. ALL LAMPS DO NOT LIGHT.**

Step 1. Check for burned out fuse in towing vehicle.

Replace fuse if burned out.

Step 2. Check for loose receptacle ground leads.

a. Remove front access cover (fig. 4-17).

b. Check for loose ground leads. Tighten if loose.

c. Replace access cover.

**2. ONE OR MORE LAMPS (BUT NOT ALL) WILL NOT LIGHT**

Step 1. Check for burned out lamp.

Replace burned out lamp.

Step 2. Check for corroded or dirty lamp sockets.

Clean lamp sockets.

Step 3. Check for a broken circuit.

Refer to chassis wiring schematic (fig. 4-15) and check circuit with a multimeter (para 4-9).

**3. DIM OR FLICKERING LIGHTS.**

Check for loose receptacle ground leads,

See Step 2 under Malfunction 1, *ALL LMPS DO NOT LIGHT*.

---

**BRAKE SYSTEM**

**4. BRAKES WILL NOT RELEASE.**

Step 1. Check for broken brake shoe tension spring. Remove wheel and tire and brake drum to expose wheel brake (para 4-49).

If brake shoe tension spring is broken, replace the spring (para 4-33 or 4-34).

Step 2. Test for leaking fail-safe chamber (para 4-39 or 4-40).

If fail-safe chamber is leaking, replace fail-safe chamber (para 4-39 or 440).

Step 3. Charge air system from towing vehicle or outside source.

Check for leaks in secondary reservoir and connections if brakes still do not release.

Table 4-9. Unit Troubleshooting (Con't).

**MALFUNCTION****TEST OR INSPECTION****CORRECTIVE ACTION****BRAKE SYSTEM (Con't)****5. NO BRAKES OR WEAK BRAKES.**

- Step 1. Test for leaking air chamber diaphragm (para 4-37 or 4-38).  
If air chamber is leaking, replace air chamber (para 4-37 or 4-38).
- Step 2. Inspect for grease on brake linings. Remove wheel and tire and hub and drum to expose wheel brake (para 4-49). If grease is evident, inspect wheel seal for damage.  
Replace brake shoes (para 4-33 or 4-34). If wheel seal is damaged, replace (para 4-49).
- Step 3. Inspect for worn brake linings.  
If brake linings are worn within .030-inch of rivet heads, replace brake shoes (para 4-33 or 4-34).
- Step 4. Test relay emergency valve (para 4-44).  
If there is leakage or hesitation in brake application or release, replace relay emergency valve (para 4-44).

**6. SLOW BRAKE APPLICATION OR SLOW RELEASE.**

- Step 1. Test for leaking air chamber diaphragm (para 4-37 or 4-38).  
if air chamber is leaking, replace air chamber (para 4-37 or 4-38).
- Step 2. Check for broken brake shoe tension spring. Remove wheel and tire and brake drum to expose wheel brake (para 4-49).  
If brake shoe tension spring is broken, replace the spring (para 4-33 or 4-34).
- Step 3. Test relay emergency valve (para 4-44).  
If there is leakage or hesitation in brake application or release, replace relay emergency valve (para 4-44).

**7. GRABBING BRAKES.**

- Step 1. Check for improperly adjusted brakes (para 4-33 or 4-34). Check automatic adjusters.  
Adjust brakes (para 4-33 or 4-34).
- Step 2. Inspect for grease on brake linings. Remove wheel and tire and hub and drum (para 4-49) to expose wheel brake. If grease is evident, inspect wheel Seal for damage.  
Replace brake shoes (para 4-33 or 4-34). If wheel seal is damaged, replace (para 4-49).
- Step 3. Inspect for loose or worn wheel bearings.  
If wheel bearings are loose, adjust to the proper preload (para 4-49). If they cannot be adjusted properly, replace wheel bearings (para 4-49).

*Take 4-9. Unit Troubleshooting (Con't).*

---

<b>MALFUNCTION</b>
<b>TEST OR INSPECTION</b>
<b>CORRECTIVE ACTION</b>

---

**BRAKE SYSTEM (Con't)**

**7. GRABBING BRAKES (Con't).**

Step 4. Inspect for worn or loose brake linings.

If brake linings are worn within .030-inch of rivet heads, replace brake shoes (para 4-33 or 4-34). If linings are loose, replace brake shoes.

Step 5. Inspect for cracked, scored, or deformed brake drum.

**Replace brake drum.**

**8. BRAKE DRAG (ONE OR MORE BRAKE DRUMS RUNNING HOT).**

Step 1. Check if brakes are adjusted too tightly (para 4-33 or 4-34).

*a.* Adjust brakes if too tight (para 4-33 or 4-34).

*b.* Check automatic adjusters (para 4-33 or 4-34). If not working, refer to Malfunction 9, *AUTOMATIC ADJUSTERS NOT WORKING.*

Step 2. Test for leaking fail-safe chamber (para 4-39 or 4-40).

If fail-safe chamber is leaking, replace fail-safe chamber (para 4-39 or 4-40).

Step 3. Check for broken brake shoe tension spring. Remove wheel and tire and brake drum (para 4-49) to expose wheel brake.

If brake shoe tension spring is broken, replace the spring (para 4-33 or 4-34).

Step 4. inspect for out-of-round drum.

Replace if out-of-found.

**9. AUTOMATIC ADJUSTERS NOT WORKING (M967, M969, and M970 except M970 SN TC-0843, TC-0844, and TC-103 thru TC-178).**

Step 1. Check if adjusting pawl is properly installed.

Install adjusting pawl properly (para 4-36).

step 2. Check if pawl spring is collapsed or missing.

Replace pawl spring (para 4-36).

Step 3. Check if adjusting bolt is frozen in adjusting sleeve.

Free bolt. Replace if necessary (para 4-36).

Step 4. Check if detent spring is damaged and allowing adjusting bolt to rotate with sleeve.

Replace detent spring (para 4-36).

Step 5. Check if adjusting plunger is in wrong position.

Adjusting plunger should beat leading edge of shoe. Install properly (para 4-36).



*Table 4-9. Unit Troubleshooting (Con't).*

---

**MALFUNCTION****TEST OR INSPECTION****CORRECTIVE ACTION**

---

**BRAKE SYSTEM (Con't)****9. AUTOMATIC ADJUSTERS NOT WORKING (M967, M969, and M970 except M970 SN TC-0843, TC-0644, and TC-103 thru TC-178) (Con't).**

Step 6. Check If double lip seals are installed properly.

Install lip seals property (para 4-36).

---

**LANDING GEAR****10. DIFFICULTY IN TURNING CRANK.**

Check if lower leg is bent. If bend is not visible, check centering of lower leg at various positions.

Replace entire leg assembly (para 4-54). Refer repair of leg assembly to direct support maintenance.

---

**MANHOLE COVER****11. EXCESSIVE LEAKAGE AROUND MANHOLE.**

Step 1. Check that fill cover Is property closed.

Check for damage to fill cover hinge parts and latch. Replace any damaged parts (para 4-60).

step 2. Inspect fill cover gasket for damage.

If damaged, replace gasket (para 4-60).

Step 3. Check tightness of manhole clamping ring.

If loose, tighten nut and bolt.

Step 4. Inspect manhole gasket for damage.

if damaged, replace the gasket (para 4-60).

**12. FILL COVER LATCH INOPERABLE.**

Check for a broken spring in fill cover latch.

If broken, replace spring (para 4-60).

*Table 4-9. Unit Troubleshooting (Con 't).*

---

**MALFUNCTION**

**TEST OR INSPECTION**

**CORRECTIVE ACTION**

---

**ENGINE**

**13. ENGINE STARTER MOTOR WILL NOT RUN.**

Step 1. Check condition of battery.

**NOTE**

**Do not slave start or Jump start batteries.**

Charge battery if discharged (para 4-23).

Step 2. Check for a blown circuit breaker.

Replace blown circuit breaker.

Step 3. Test for a defective Engine or Starter switch. Use a multimeter or a 12V test light.

If either switch is defective, replace that switch.

Step 4. Test for a defective starter solenoid (para 4-80).

If defective, replace solenoid.

**14. ENGINE TURNS OVER BUT FAILS TO START**

Step 1. Check engine temperature.

*a. If engine temperature is below 240°F, test high-temperature switch (para 4-22).*

*b. If temperature is above 240°F, the high-temperature switch (para 4-22) contacts have opened and de-energized the fuel stop solenoid, stopping the engine. Allow engine to cool before attempting to start engine again.*

Step 2. Check for defective manifold heater and lead (para 4-20).

If defective, replace the manifold heater or the lead.

Step 3. (Defective fuel system) Check fuel lines for leaks. Test for non-functioning electric fuel pump (para 4-73).

*a. Tighten all connections and replace or repair any damaged fuel lines.*

*b. Replace electric fuel pumps (para 4-73), if defective, or repair or replace fuel pump wiring.*

Step 4. Check air cleaner dirt indicator for showing of red band and examine for clogged filter intake.

*a. Replace filter element if red band is showing (para 3-18).*

*b. Remove air cleaner intake cap and clean as necessary (para 3-18).*

*c. Replace air cleaner if damaged (para 4-74).*

**Table 4-9. Unit Troubleshooting (Con't).****MALFUNCTION****TEST OR INSPECTION****CORRECTIVE ACTION****ENGINE (Con't)****14. ENGINE TURNS OVER BUT FAILS TO START (Con't).**

Step 5. Check for dirty fuel or clogged fuel filter.

*a.* If fuel is dirty, drain and refill tank with clean fuel.

*b.* Replace dirty fuel filters (para 4-73).

Step 6. Inspect for proper grade of fuel.

Check fuel specifications (para 2-10), drain fuel tank, and fill with proper grade of fuel.

**15. ENGINE HARD TO START OR LOW ENGINE POWER.**

Step 1. Check that engine oil is the proper grade for the ambient temperature. Check oil specification charts (fig. 3-1 through 3-6).

Change to right grade of oil.

Step 2. Inspect for proper grade of fuel.

Check fuel specifications (para 2-10), drain fuel tank, and fill with proper grade of fuel.

Step 3. Inspect for fuel line leaks.

Tighten all connections, check for damage or defects to lines. Repair or replace the fuel lines (para 4-73).

Step 4. Check air cleaner dirt indicator for showing of red band, and examine for clogged filter intake.

*a.* Replace filter element if red band is showing (para 3-18).

*b.* Remove air cleaner intake cap and clean as necessary (para 3-18).

*c.* Replace air cleaner if damaged (para 4-74).

Step 5. Check for dirty fuel or clogged fuel filters.

*a.* If fuel is dirty, drain and refill tank with clean fuel.

*b.* Replace dirty fuel filters (para 4-73).

**16. LOW OIL PRESSURE (MINIMUM 20 PSI).**

Step 1. Check oil level. If low, check for external leaks.

*a.* Fill with proper oil.

*b.* If leaks are noticed, notify direct support maintenance.

*Table 4-9. Unit Troubleshooting (Con't).*

---

**MALFUNCTION**

**TEST OR INSPECTION**

**CORRECTIVE ACTION**

---

**ENGINE (Con't)**

**16. LOW OIL PRESSURE (MINIMUM 20 PSI) (Con't).**

Step 2. Inspect for defective oil gage (para 4-24).

Replace oil gage (para 4-24).

**17. HIGH OIL PRESSURE (ABOVE 40 PSI WHEN ENGINE IS WARM).**

Step 1. Check if engine is overfilled with oil.

Drain oil until oil in engine is proper level.

Step 2. Check for proper grade of oil. Oil maybe too heavy in viscosity.

Check oil specifications in Lubrication Charts (fig. 3-1 through 3-6). if wrong oil, drain the engine and refill with the proper grade of oil.

**18. ENGINE MISFIRES AT HEAVY LOAD.**

Step 1. Check for defective manifold heater and lead (para 4-20).

If defective, replace manifold heater or lead.

Step 2. (Defective fuel system) Check fuel lines for leaks. Test for non-functioning electric fuel pumps (para 4-73).

*a.* Tighten all connections and replace or repair any damaged fuel lines.

*b.* Replace fuel pump, if defective, or repair or replace fuel pump wiring (para 4-73).

Step 3. Check air cleaner dirt indicator for showing of red band and examine for clogged filter intake.

*a.* Replace filter element if red band is showing (para 3-18).

*b.* Remove air cleaner intake cap and clean as necessary (para 3-18).

*c.* Replace air cleaner if damaged (para 4-74).

Step 4. Check for dirty fuel or clogged fuel filter.

*a.* If fuel is dirty, drain and refill tank with clean fuel.

*b.* Replace dirty fuel filters (para 4-73).

Step 5. Inspect for proper grade of fuel.

Check fuel specifications (para 2-10), drain fuel tank, and fill with proper grade of fuel.

*Table 4-9. Unit Troubleshooting (Con't).***MALFUNCTION****TEST OR INSPECTION****CORRECTIVE ACTION****ENGINE (Con't)****19. ENGINE SPEED IS NOT CONSTANT (HUNTING, LOSS OF CONTROL).**

Step 1. Check for defective manifold heater and lead (para 4-20).

If defective, replace manifold heater or lead.

Step 2. (Defective fuel system) Check fuel lines for leaks. Test for non-functioning electric fuel pumps (para 4-73).

a. Tighten all connections and replace or repair any damaged fuel lines.

b. Replace fuel pump, if defective, or repair or replace fuel transfer pump wiring (para 4-73).

Step 3. Perform all steps under Malfunction 20, *HIGH OR LOW ENG/NE SPEEDS*.

**20. HIGH OR LOW ENGINE SPEEDS.**

Step 1. Check for loose or disconnected throttle linkage (para 4-75).

Connect throttle linkage.

Step 2. Check for binding in linkage.

Clean and lubricate linkage.

Step 3. Check throttle adjustment (para 4-75).

Adjust throttle linkage.

Step 4. Check governor sensitivity adjustment (para 4-76).

Adjust governor sensitivity.

**21. BLACK SMOKE EXHAUST OR EXCESSIVE FUEL CONSUMPTION.****NOTE**

**The brown or black color in the exhaust is from minute solid particles of pure carbon. A darker exhaust indicates a higher carbon content. The exhaust color may vary from a light gray haze to a brown or black, which indicates incomplete combustion. Since combustion is never absolutely complete, the exhaust gases will never be invisible, but an increase may indicate trouble, especially if there is no apparent change in engine conditions.**

Step 1. Check for engine overload.

Reduce fuel dispensing rate or increase engine speed.

*Table 4-9. Unit Troubleshooting (Con't).*

---

<b>MALFUNCTION</b>	<b>TEST OR INSPECTION</b>	<b>CORRECTIVE ACTION</b>
--------------------	---------------------------	--------------------------

---

**ENGINE (Con't)**

**21. BLACK SMOKE EXHAUST OR EXCESSIVE FUEL CONSUMPTION (Con't).**

- Step 2. Inspect for proper grade or dirty fuel,
  - Check fuel specification (para 2-10). Drain, fill with proper grade of fuel. If fuel is dirty, check fuel filter (para 4-73).
- Step 3. Inspect for dirty air cleaner.
  - a. Service air cleaner (para 3-18).
  - b. Replace air cleaner if damaged (para 4-74).

**22. PREHEAT INDICATOR LAMP WILL NOT LIGHT.**

- Step 1. Check for burned out lamp (para 4-24).
  - Replace burned out lamp.
- Step 2. Check battery conditions (para 4-23).
  - a. Clean cables and terminals.

**NOTE**

**Do not slave start or jump start batteries.**

- b. Charge battery (para 4-23).
- Step 3. Test preheat switch (para 4-24).
  - Replace if defective.
- Step 4. Remove engine junction box cover. Turn preheater solenoid switch to ON position and listen for clicking sound.
  - a. Replace preheater solenoid (para 4-18) if no sound is heard.
  - b. If sound is heard, replace manifold heaters (para 4-20).

**CENTRIFUGAL PUMP**

**23. PUMP FAILS TO DELIVER FUEL.**

- Step 1. Check if pump either has lost prime or has not been primed.
  - Prime pump (para 4-90).

**Table 4-9. Unit Troubleshooting (Con't).**

---

**MALFUNCTION****TEST OR INSPECTION****CORRECTIVE ACTION**

---

**CENTRIFUGAL PUMP (Con't)****23. PUMP FAILS TO DELIVER FUEL (Con't).**

Step 2. Check for leakage of air into pump or at connections.

Tighten all connections. If gaskets need replacement, notify direct support maintenance.

---

**BATTERY****24. DEFECTIVE BATTERY**

Step 1. Check specific gravity of battery (para 4-23).

If specific gravity is low, recharge battery (para 4-23). If battery will not charge, replace battery. Check new battery charge conditions at frequent intervals (para 4-23).

Step 2. Check for frayed or broken cables.

Replace cables (para 4-23).

Step 3. Check for loss of electrolyte in battery.

Service battery (para 4-23).

Step 4. Inspect for broken terminals.

Replace terminals.

**25. BATTERY DISCHARGED.**

Inspect for dirt and electrolyte on top of battery causing constant drain (para 4-23).

Clean battery top.

---

**FILTER/SEPARATOR****26. FUEL DOES NOT FLOW DURING FUEL SERVICING OPERATION.**

Check filter/separator gage reading, If gage registers 25 psi or more, the fuses are clogged.

Replace clogged fuses (para 4-83).

**27. CONTINUOUS SEEPAGE FROM AUTOMATIC DRAIN VALVE.**

Inspect for liquid other than water seeping out of automatic water drain valve (fig. 4-127).

Notify direct support maintenance.

*Table 4-9. Unit Troubleshooting (Con't).*

---

**MALFUNCTION**

**TEST OR INSPECTION**

**CORRECTIVE ACTION**

---

**PIPING CONTROL COMPONENTS**

**28. EMERGENCY VALVE WILL NOT OPEN OR CLOSE OR LEAKS OCCUR.**

- Step 1. Inspect for loose cable at valve operator A and at the emergency valve (fig. 4-90).
- a. Tighten cable connecting U-bolt and nuts at emergency valve.
  - b. Tighten cable bolt and nut at nut on valve operator A. Adjust cable (para 4-51).
- Step 2. Check for loose nut on stuffing box.
- Tighten nut if loose.
- Step 3. Check if nuts on flange are loose.
- Tighten loose nuts. If nuts are not loose and leakage is around flange, notify direct support maintenance.

**29. EMERGENCY VALVE CONTROL OPERATES IMPROPERLY.**

- Step 1. Check for loose cable at valve operator A (fig. 4-90).
- Tighten nut on connector bolt.
- Step 2. Check tension on trip lever or release lever (fig. 4-90).
- a. If spring is broken, replace.
  - b. Tighten adjusting bolt and nut on trip link.

**30. GATE VALVES OPERATE IMPROPERLY.**

- Inspect for leaks around hand wheel stem.
- Open valve to raise lock housing. Tighten stuffing box nut.
- 

**FUELING OPERATIONS**

**31. FUEL DOES NOT FLOW DURING ANY NON-FILTERED FUELING OPERATIONS.**

- Check if emergency valve can open, Open valve by operating emergency valve control A (fig. 4-90).
- If valve does not open, adjust, repair, or replace emergency valve control and cables (para 4-51).

**32. FUEL DOES NOT FLOW DURING ANY FILTERED OPERATION (M969, M969A1, M970, and M970A1).**

- Step 1. Check if emergency valve can open. Open valve by operating emergency valve control A (fig. 4-90).
- If valve does not open, adjust, repair, or replace emergency valve control and cables (para 4-51).



**Table 4-9. Unit Troubleshooting (Con't).**

MALFUNCTION	TEST OR INSPECTION	CORRECTIVE ACTION
<b>FUELING OPERATIONS (Con't)</b>		
<b>32. FUEL DOES NOT FLOW DURING ANY FILTERED OPERATION (M969, M969A1, M970, and M970A1) (Con't).</b>		
Step 2.	Check filter/separator gage registers 25 psi or more, the fuses are clogged.	Replace clogged fuses (para 4-82).
Step 3.	Check for plugged nozzle screen.	Clean screen (paras 3-14 through 3-17).
<b>33. FUEL DOES NOT FLOW DURING OVERWING FUELING OPERATION (M970 and M970A1).</b>		
Step 1.	Complete steps 1 and 2 under Malfunction 32, <i>FUEL DOES NOT FLOW DURING ANY FILTERED FUELING OPERATION</i> .	
Step 2.	<p data-bbox="418 957 1029 978">Check if deadman control is deactivated (para 2-11).</p> <p data-bbox="483 1005 1523 1094"><i>a.</i> If deadman control cannot be deactivated, check deadman control hoses for kinks. Straighten kinks. Check deadman hoses for breaks. Check connections for leaks. Replace damaged hoses and tighten loose connections (para 4-92).</p> <p data-bbox="483 1115 1523 1173"><i>b.</i> If deadman control checks out, inspect and test deadman release plunger circuit (para 4-95). Replace any faulty component and tighten any loose connections.</p>	
<b>34. FUEL DOES NOT FLOW DURING ANY UNDERWING FUELING OPERATION (M970 and M970A1).</b>		
Step 1.	Complete steps 1 and 2 under Malfunction 32, <i>FUEL DOES NOT FLOW DURING ANY FILTERED FUELING OPERATION (M969, M969A1, M970, and M970A1)</i> .	
Step 2.	<p data-bbox="418 1346 1024 1367">Check if deadman control is inoperable (para 4-89).</p> <p data-bbox="483 1394 1198 1415"><i>a.</i> Check deadman control hoses for kinks. Straighten kinks.</p> <p data-bbox="483 1446 1523 1503"><i>b.</i> Check deadman hoses for leaks or loose connections. Replace hoses and tighten loose connections (para 4-89).</p> <p data-bbox="483 1530 1052 1551"><i>c.</i> If handle control is faulty, replace the control.</p>	

Section V. PAINTING AND STENCILING

4-7. Painting and Stenciling

**WARNING**

*a.* General instructions are included in TB 43-0209 and TM 43-0139.

*b.* Spot painting and marking (stenciling) of tactical vehicles will be performed under the control of unit maintenance personnel.

*c.* Painting of a complete tactical vehicle can be authorized and performed only by direct support maintenance or by higher support elements.

**DO NOT paint the semitrailer's grounding studs. To ensure safe operation of fuel handling equipment, proper bonding and grounding connections must be made to clean, unpainted surfaces. Failure to follow this warning may result in injury or death to personnel.**

*d.* To ensure proper bonding and grounding connections, DO NOT paint the semitrailer's grounding studs.

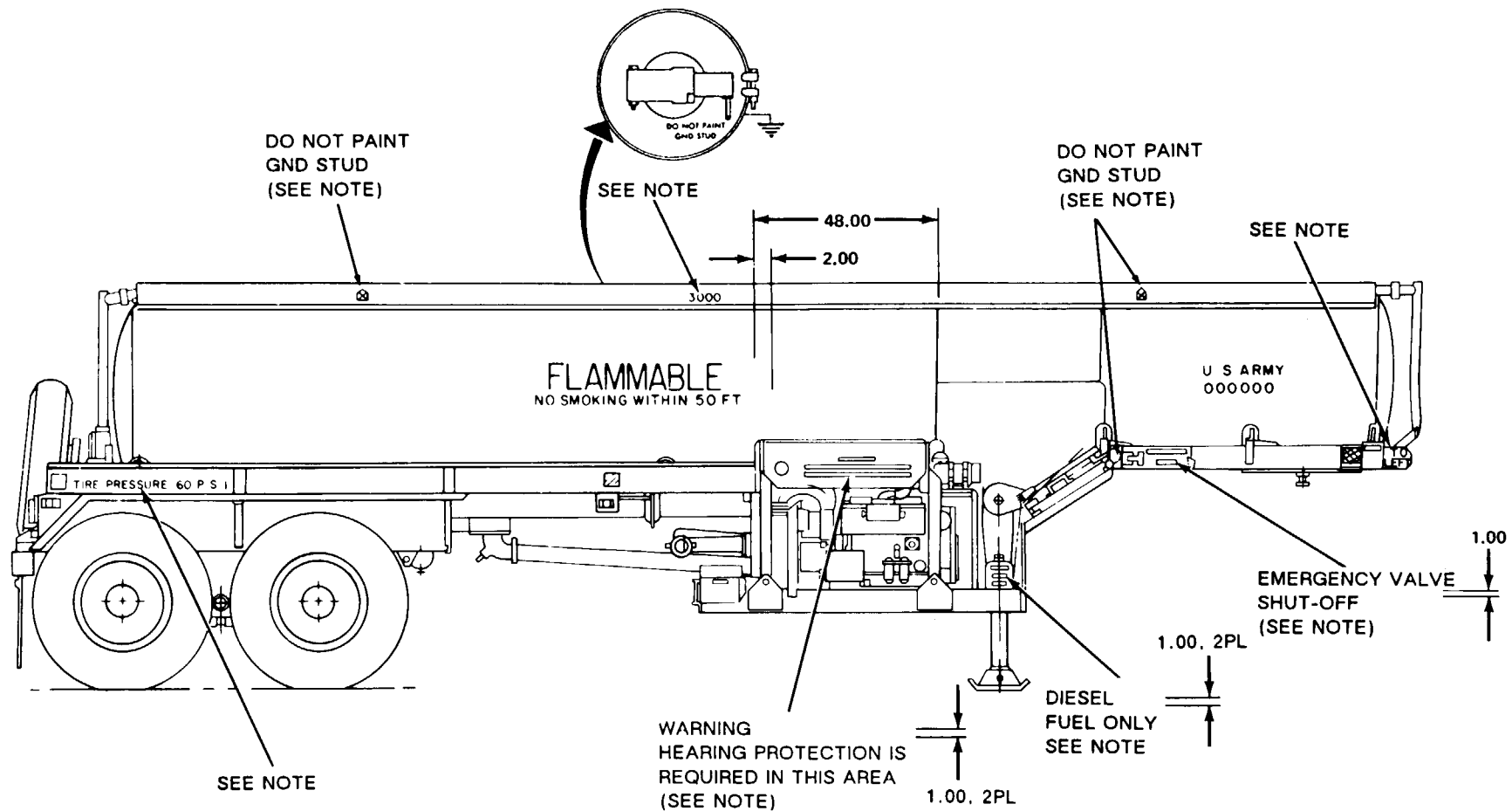

 GROUND SYMBOL STENCILED IN BLACK PER TT-P-98 AT ALL GROUNDING STUDS.

NOTE  
LETTERS ARE 1" HIGH

Figure 4-1. Stenciling Typical (M967 and M967A1) (Sheet 1 of 2).

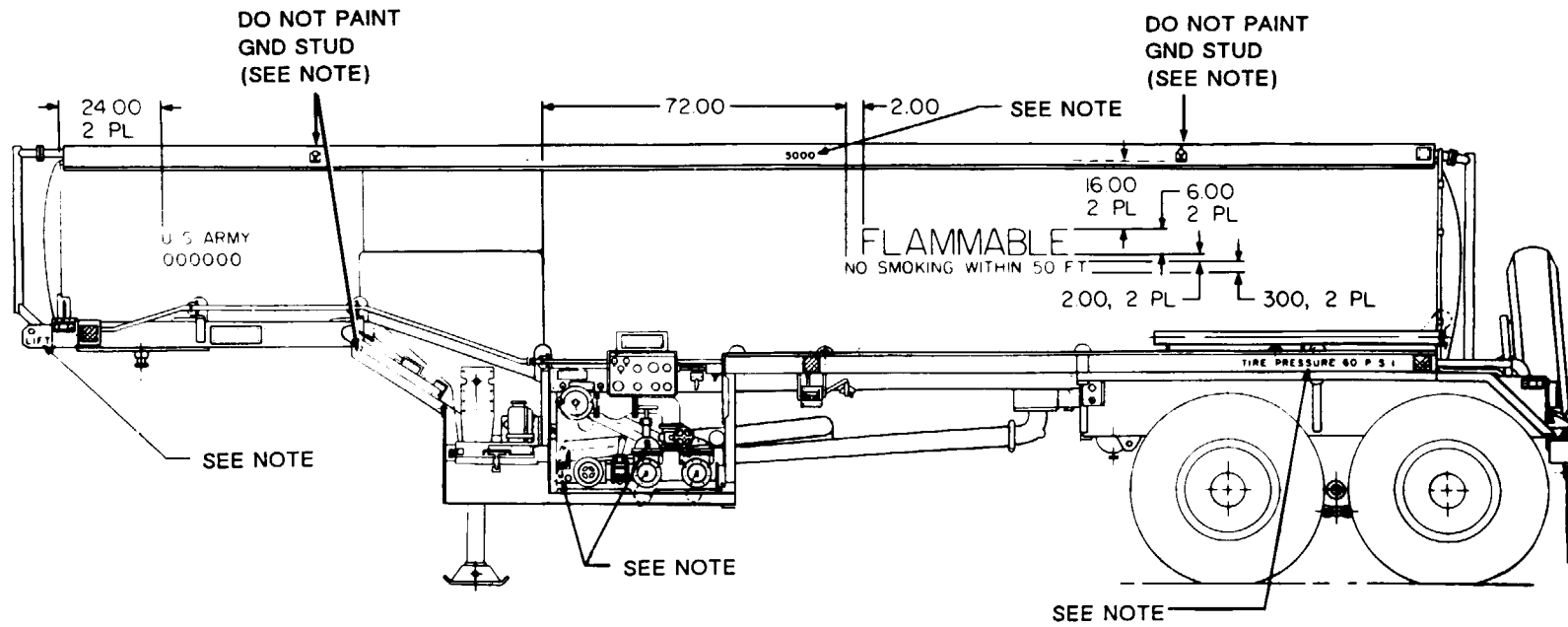

NOTE  
LETTERS ARE 1" HIGH

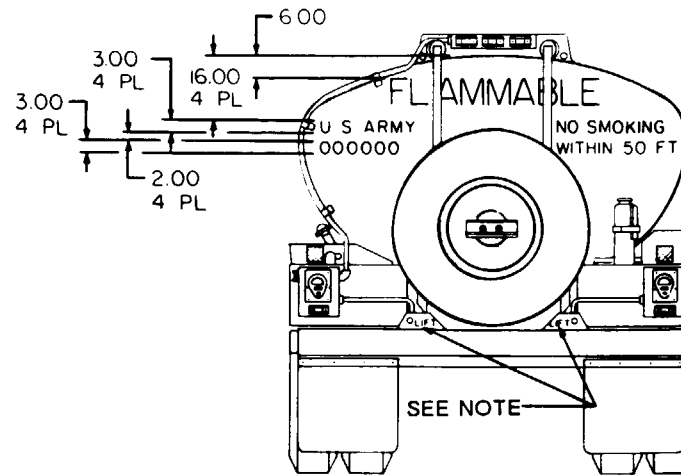



 GROUND SYMBOL STENCILED IN BLACK PER TT-P-98 AT ALL GROUNDING STUDS.

Figure 4-1. Stenciling Typical (M967 and M967A1) (Sheet 2 of 2).

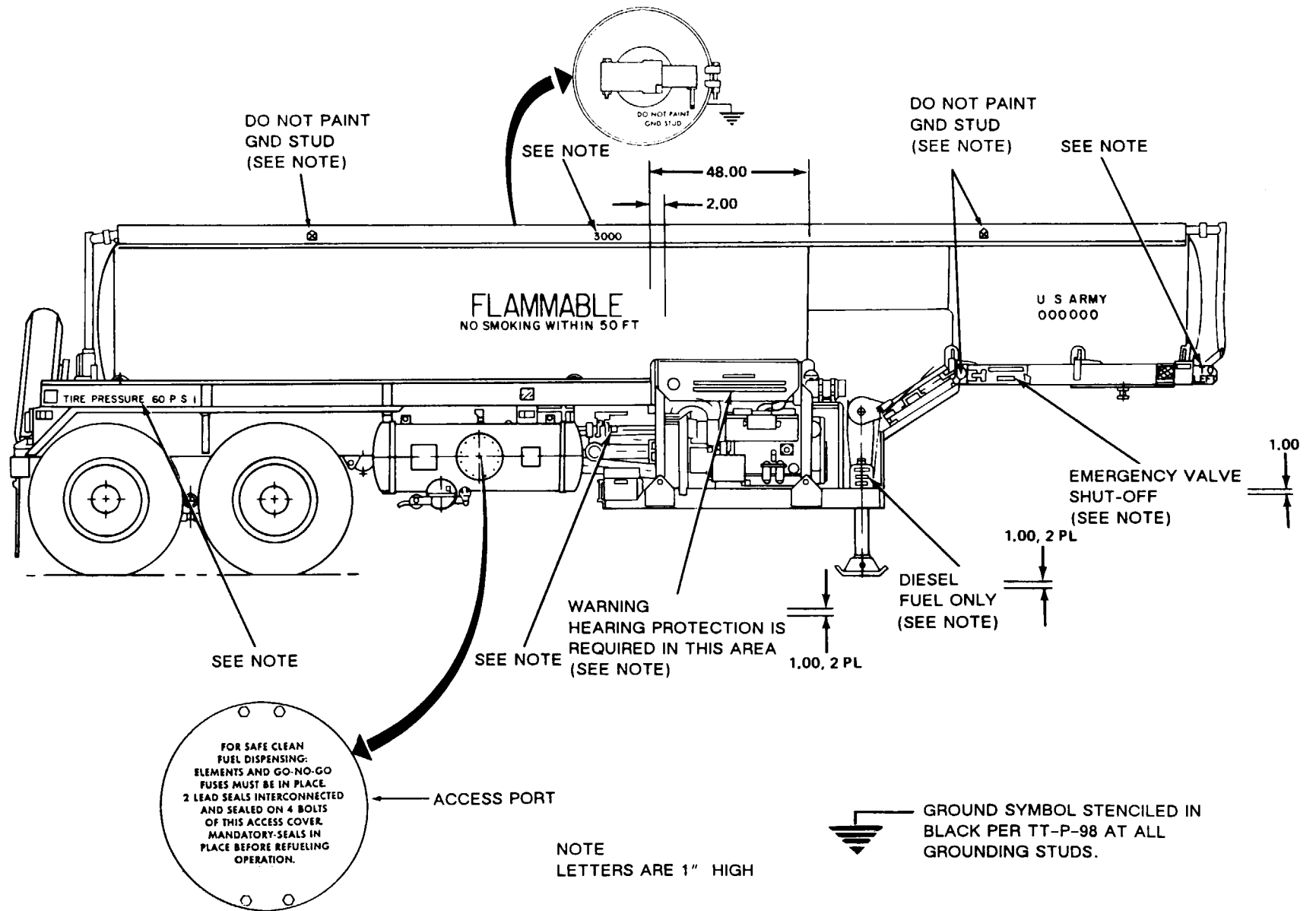
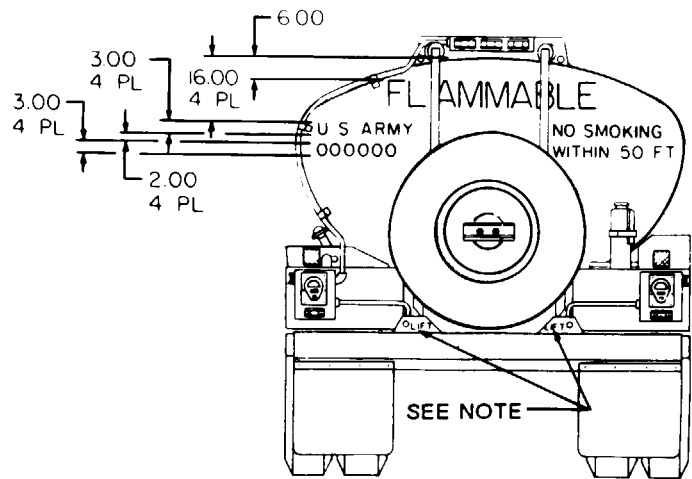
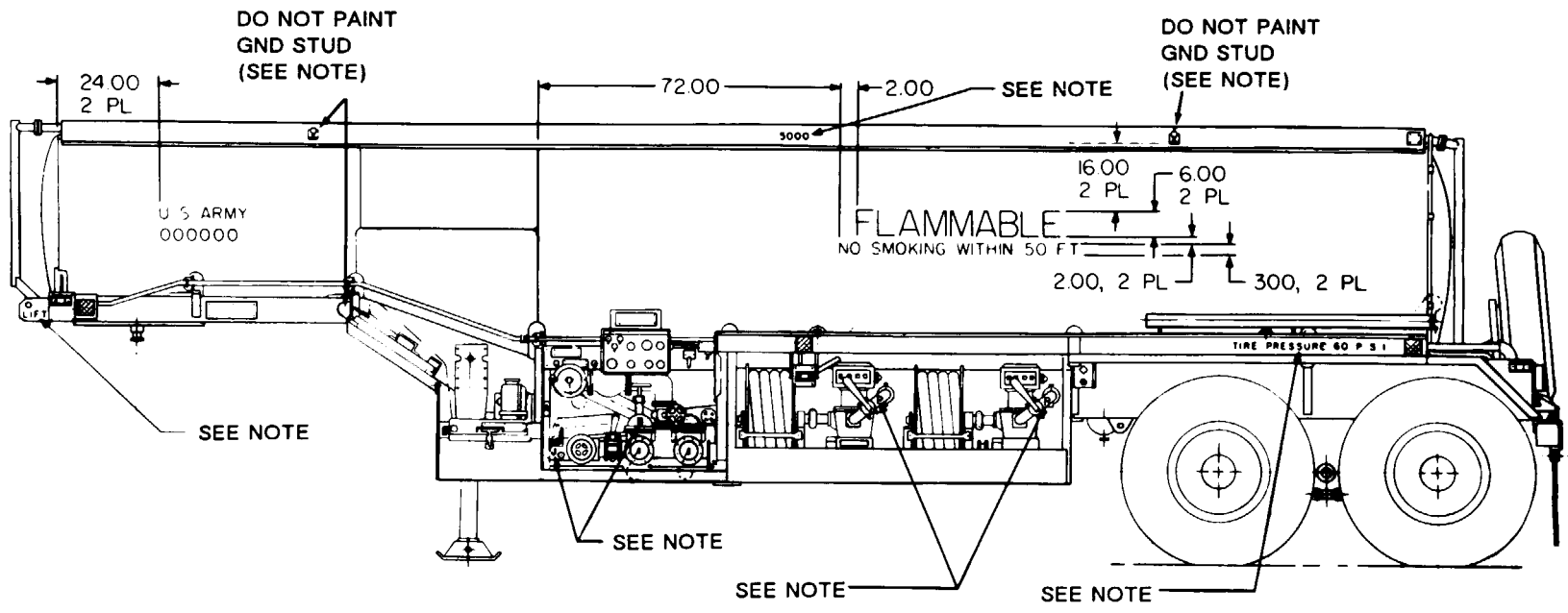

Figure 4-2. Stenciling Typical (M969 and M969A1) (Sheet 1 of 2).



NOTE LETTERS ARE 1" HIGH



 GROUND SYMBOL STENCILED IN BLACK PER TT-P-98 AT ALL GROUNDING STUDS.

Figure 4-2. Stenciling Typical (M969 and M969A1) (Sheet 2 of 2).

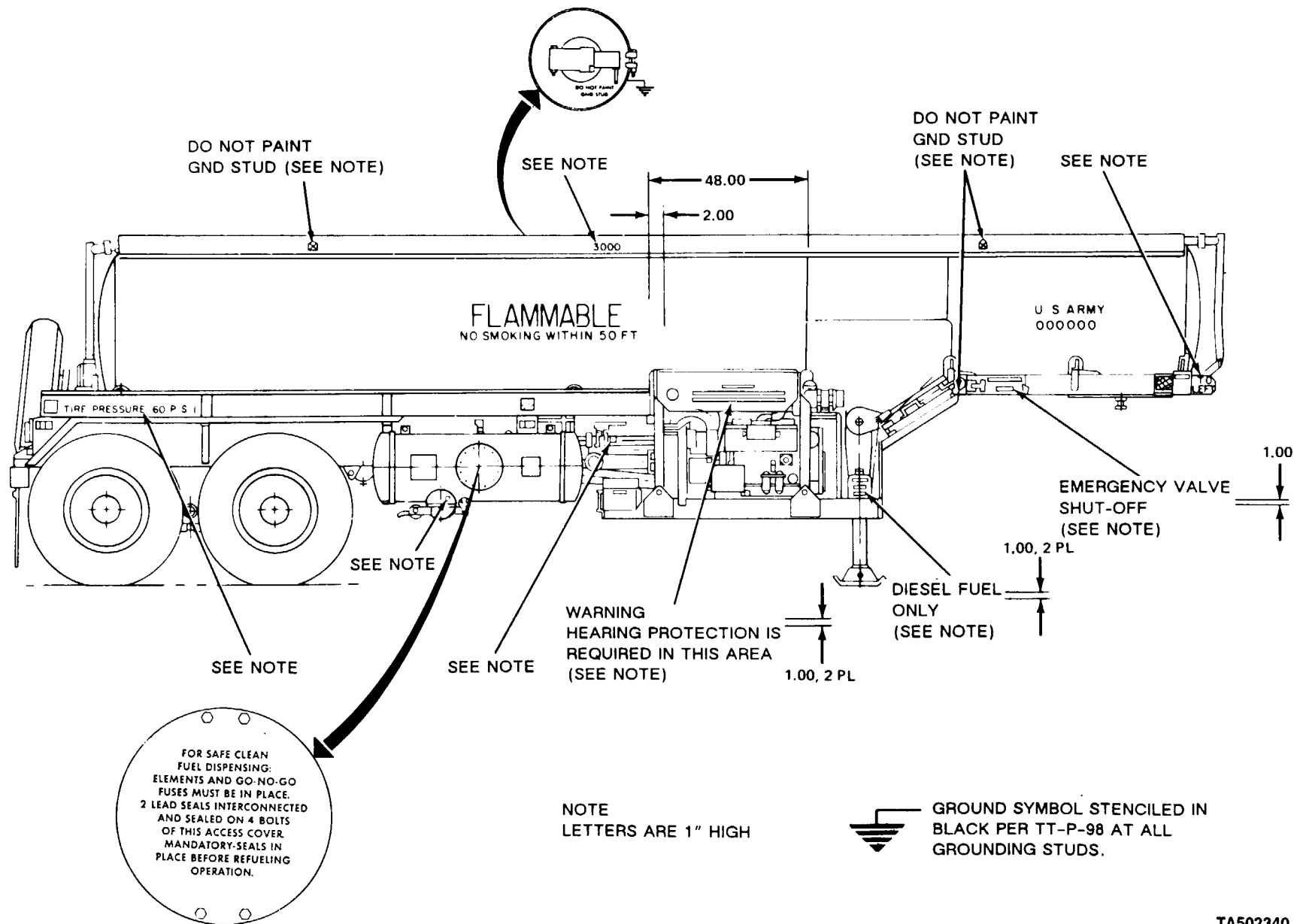
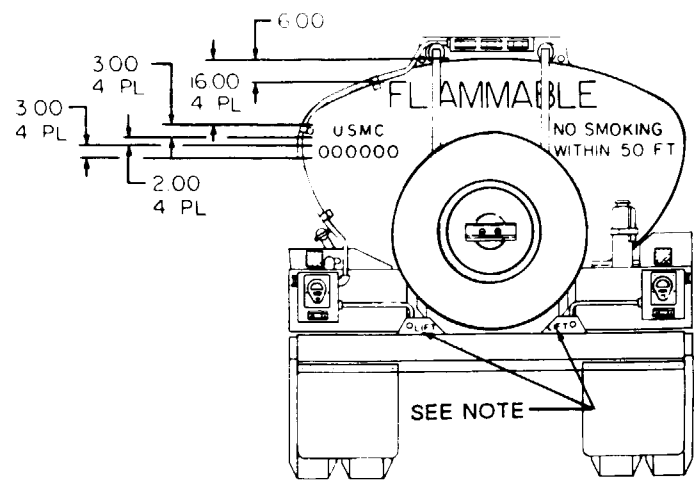
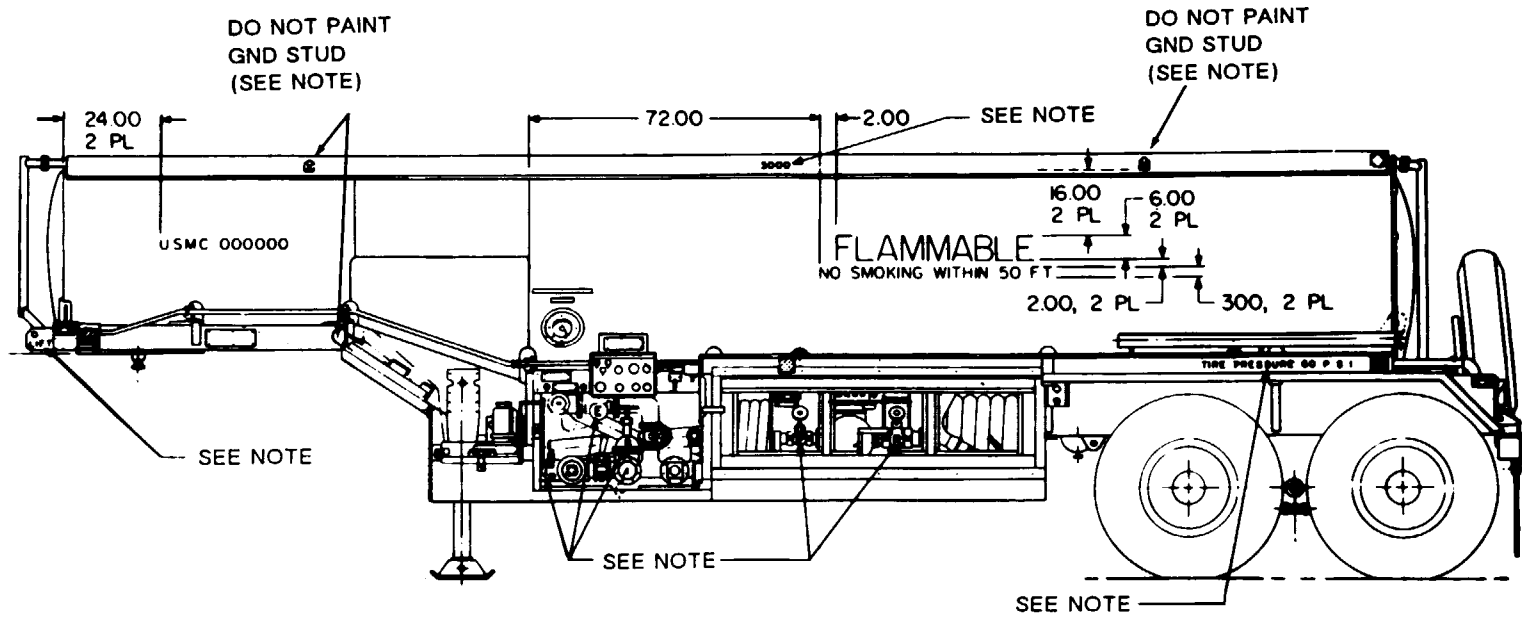

Figure 4-3. Stenciling Typical (M970 and M970A1) (Sheet 1 of 2).

TA502340



GROUND SYMBOL STENCILED IN BLACK PER TT-P-98 AT ALL GROUNDING STUDS.

NOTE  
LETTERS ARE 1" HIGH

Figure 4-3. Stenciling Typical (M970 and M970A1) (Sheet 2 of 2).



**Section VI. TESTING THE ELECTRICAL SYSTEM WITH A MULTIMETER**

**4-8. Electrical Diagrams**

When testing the electrical system, refer to all wiring diagrams. Detailed illustrations and procedures are provided for complete testing of the electrical system on this vehicle.

**4-9. Multimeters**

Any one of three multimeters may be found in the Common Number 1 and Common Number 2 Organiza-

tional Maintenance Automotive Shop Sets. The three meters, shown in figure 4-4, are the Simpson 160, the TS-352 B/U, and the AN/URM-105. These meters all do the same job, and any one of the three can be used to troubleshoot the semitrailer. The ohms scale is used to test for continuity, shorts, and resistance. The voltmeter scale is used to test voltage levels at any point in the electrical system.

SIMPSON 160



NOTE: THE SIMPSON 160 IS ONLY AVAILABLE IN NEW SHOP SETS AS A SUBSTITUTE FOR THE TS-322B U or AN URM 105.

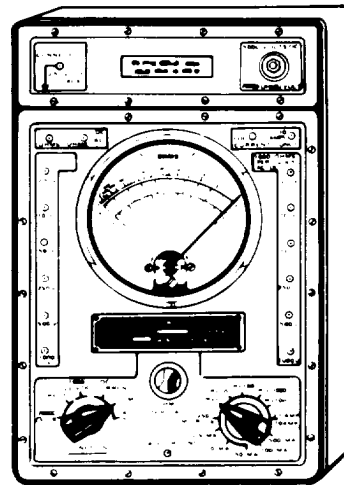

TS-3528/U

AN/URM 105

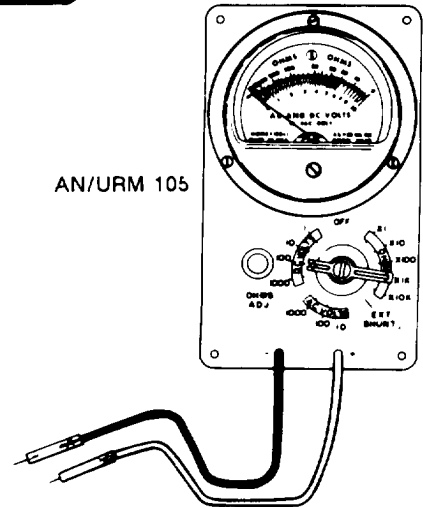

TA099760

*Figure 4-4. Shop Set Multimeters.*

4-10. Using the Ohms Scale

**WARNING**

When troubleshooting an electrical malfunction or performing electrical maintenance, ALWAYS disconnect Intervehicular electrical cable from semitrailer, and negative battery cables at batteries. Failure to follow this warning may create a spark and explosion, resulting in serious injury or death to personnel.

**NOTE**

if the needle will not zero properly, replace the batteries and try the zeroing procedure

again. if the needle will not zero after you have replaced the batteries, turn the meter in for repair.

a. *Zero the Meter.* To obtain an accurate reading, you must first adjust the meter so that when there is zero resistance, the needle gives a reading of zero. Use the appropriate procedure below for the type of meter in your shop set.

(1) *AN/URM-105.* Use the procedure shown in figure 4-5.

(2) *TS-352 B/U.* Use the procedure shown in figure 4-6.

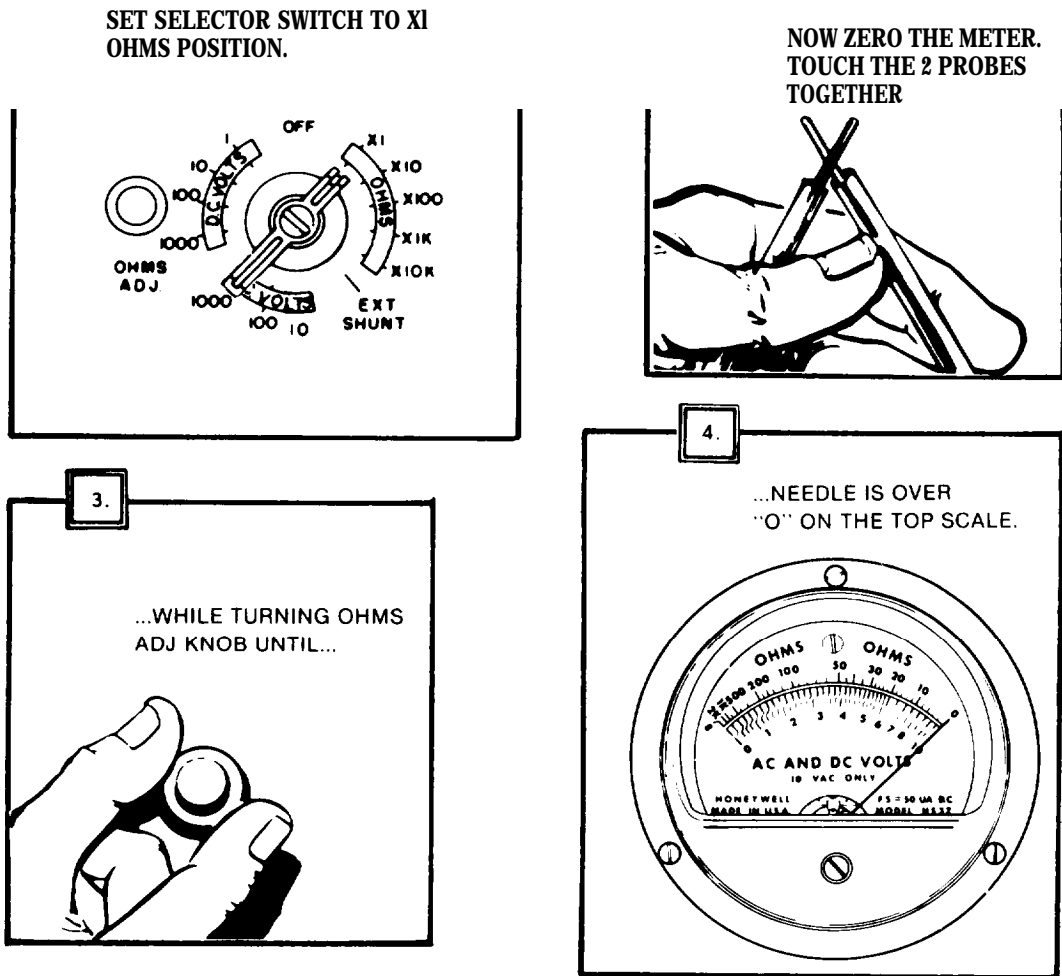

**NOTE:** IF NEEDLE WILL NOT "ZERO" REPLACE THE BATTERIES. IF THE NEEDLE STILL WILL NOT "ZERO" AFTER REPLACING THE BATTERIES, TURN THE METER IN FOR REPAIR,

Figure 4-5. Zeroing the AN/URM-105.

TA099761

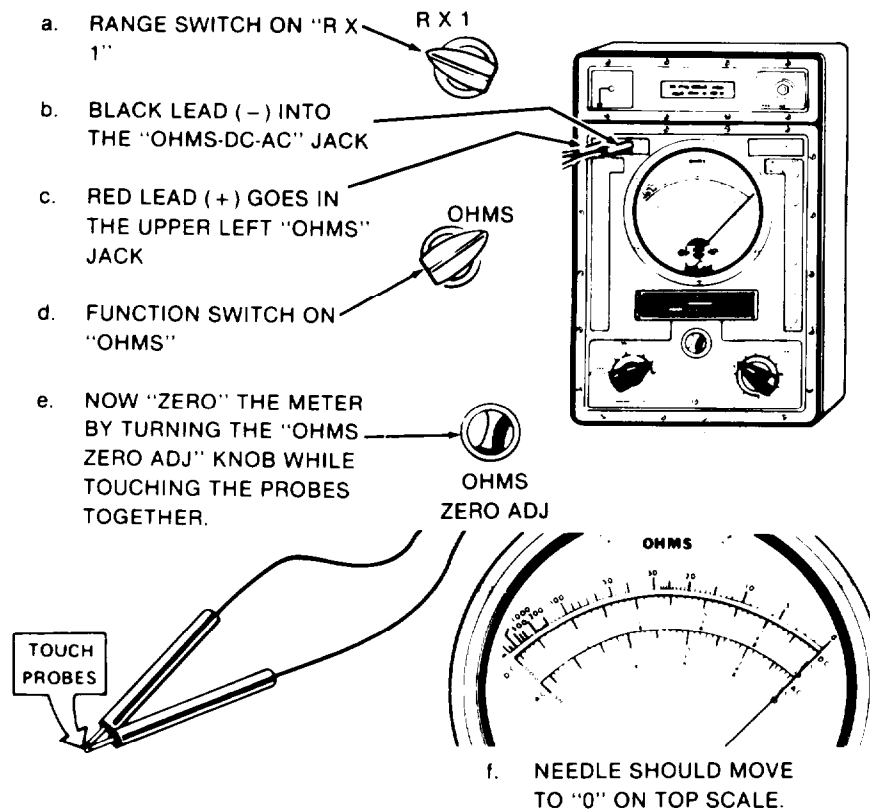

- a. RANGE SWITCH ON "R X 1"
- b. BLACK LEAD (-) INTO THE "OHMS-DC-AC" JACK
- c. RED LEAD (+) GOES IN THE UPPER LEFT "OHMS" JACK
- d. FUNCTION SWITCH ON "OHMS"
- e. NOW "ZERO" THE METER BY TURNING THE "OHMS ZERO ADJ" KNOB WHILE TOUCHING THE PROBES TOGETHER.

f. NEEDLE SHOULD MOVE TO "0" ON TOP SCALE.

TA099762

Figure 4-6. Zeroing the TS-352 B/U.

(3) *Simpson 160*, Refer to figure 4-7.

- (a) Set the selector switch to RX1.
- (b) Put the black probe in the COM-jack.
- (c) Put the red probe in the + jack.
- (d) Now zero the meter by touching the probes together and turning the ADJ knob until the needle is over the (1 on the top scale).

b. *Continuity Tests.* Continuity tests are made to check for breaks in a circuit (such as a switch, light bulb, or electrical cable). Make a continuity check as follows:

(1) Zero the meter (para 4-10).

**CAUTION**

**Failure to disconnect the battery ground cable (or outside power source) can damage the meter.**

(2) Disconnect the battery ground cable at the battery. Then disconnect the circuit you are going to test.

(3) Connect the meter probes to both terminals of the circuit you are testing (fig. 4-8).

(4) Read the meter. Interpret the results as follows:

(a) If the needle swings over the 0 on the top scale, the circuit has continuity.

(b) If the needle doesn't move, the circuit is open. The wire is broken and must be replaced.

(c) If the needle jumps or flickers, there is a loose connection somewhere in the circuit being tested. Make sure the meter leads are pressed firmly against the test points. If the meter lead connections are firm, tighten all connections in the circuit. If the needle still jumps, there may be an intermittent open in the wiring; the wire should be replaced.

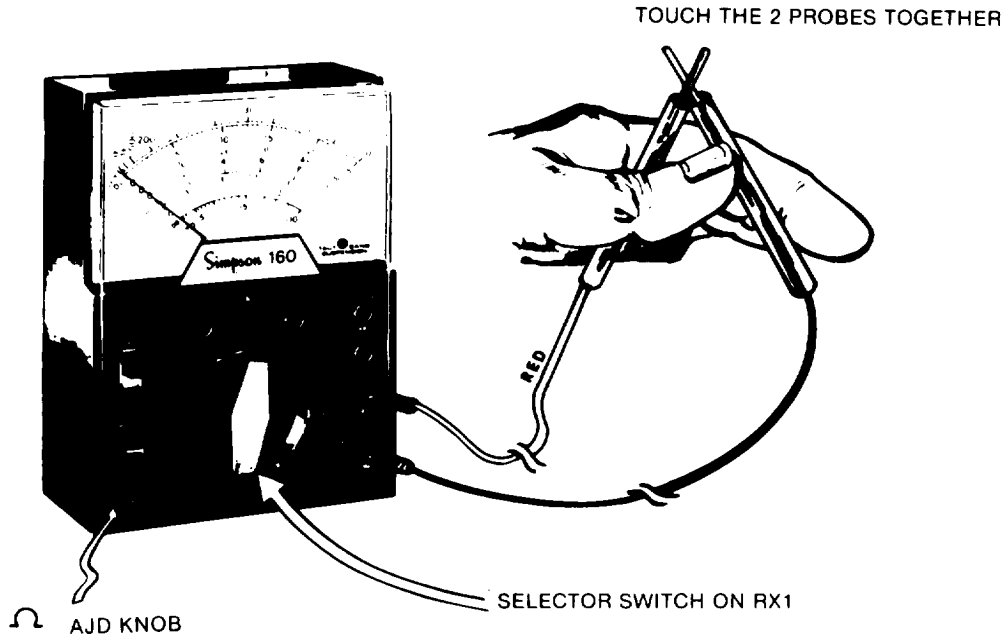

**NOTE:** IF NEEDLE WILL NOT "ZERO" REPLACE THE BATTERIES. IF THE NEEDLE STILL WILL NOT "ZERO" AFTER REPLACING THE BATTERIES, TURN THE METER IN FOR REPAIR.

TA099763

Figure 4-7. Zeroing the Simpson 160.

c. *Testing for Shorts.* A short (or short circuit) occurs when two circuits that should not be connected have metal-to-metal contact with each other. A short also occurs when a circuit that should not touch ground has metal-to-metal contact with ground. To check for shorts, do as follows:

- (1) Zero the multimeter (para 4-10).

**CAUTION**

**Failure to disconnect the battery ground cable (or outside power source) can damage the meter.**

- (2) Disconnect the battery ground cable at the battery. Then disconnect the circuit being tested.

- (3) Connect one probe to one circuit and the other probe to either the other circuit or to ground (fig. 4-9). The figure shows how to test for a short between two wires.

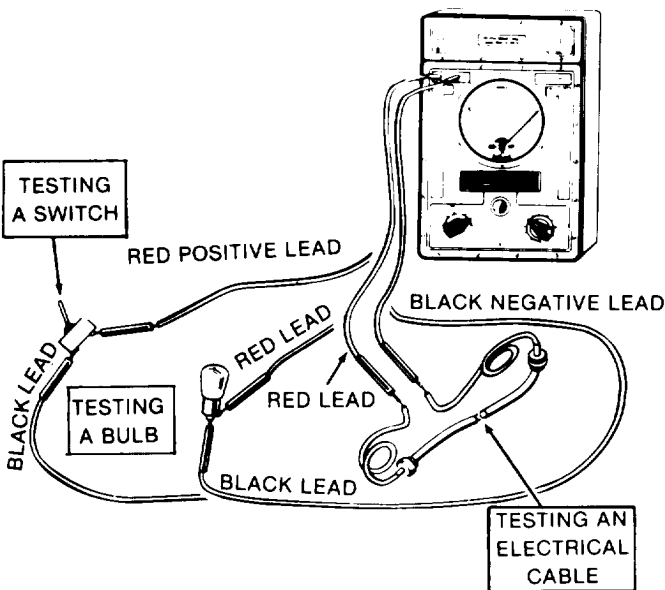

TA099764

Figure 4-8. Using the Meter to Test Continuity.

(4) Read the meter. Interpret the results as follows:

(a) If the needle swings toward the 0 on the top scale, the circuits are shorted (or the circuit is grounded, if testing to ground).

(b) If the needle doesn't move, the circuits are okay.

(c) If the needle jumps or flickers, the circuits are shorted (or grounded) intermittently.

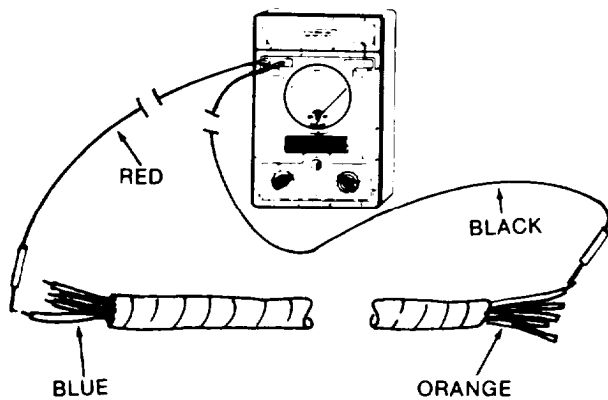

TA099765

Figure 4-9. Using the Meter to Test for Shorts or Grounds.

d. *Testing Resistance.* Allowable resistance readings depend on the circuit being tested. For most direct wiring circuits (e.g., lighting), a maximum of 3 ohms within the wiring is satisfactory. Where other ohms readings are allowable (e.g., 10,000 ohms in the coil), they are specified in the particular section dealing with that circuit or component. Test resistance as follows:

(1) Zero the meter (para 4-10).

**CAUTION**

**Failure to disconnect the battery ground cable (or outside power source) can damage the meter.**

(2) Disconnect the battery ground cable at the battery. Then disconnect the circuit being tested.

**NOTE**

**Whenever you change switch settings, zero the meter again.**

(3) Select the correct ohms switch setting (table 4-10). For normal circuits where 3 ohms is the maximum allowable reading, use the X1 or RX1 scale (fig. 4-10).

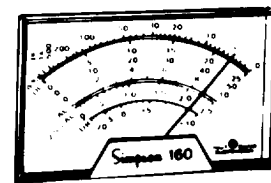
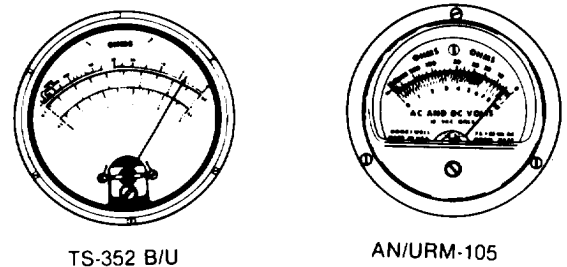

SIMPSON 160

TA099766

Figure 4-10, Interpreting Meter Readings.

Table 4-10. Ohms Range Switch Setting.

Switch	How to read scale	Meter reads	Reading means
X1 or RX1	Read the number on the scale	4	400 ohms
X10 or RX 10	Multiply scale reading by 10	4	40 ohms
X100 or RX100	Multiply reading by 100	4	400 ohms
X1K or RX1K	Multiply reading by 1000	—	—
X10K or RX10K	Multiply reading by 10000	—	—

**4-11. Using the DC Volts Scale**

Use the DC volts scale to measure all voltages; the AC volts scale is never used on these semitrailers.

a. *Setting up the Meter.* Before reading the meter, set it up using the procedure below that matches the multimeter in your shop set.

**CAUTION**

**If you are not sure of the voltage you will be measuring, ALWAYS select the 50V range (100V range on the AN/URM-105).**

(1) AN/URM-105. Set the meter switch to the DC volts range set forth in the testing paragraph for the component or circuit you are testing. (For most circuits on the semitrailer, the right range is the one marked 100 DC Volts) (fig. 4-11).

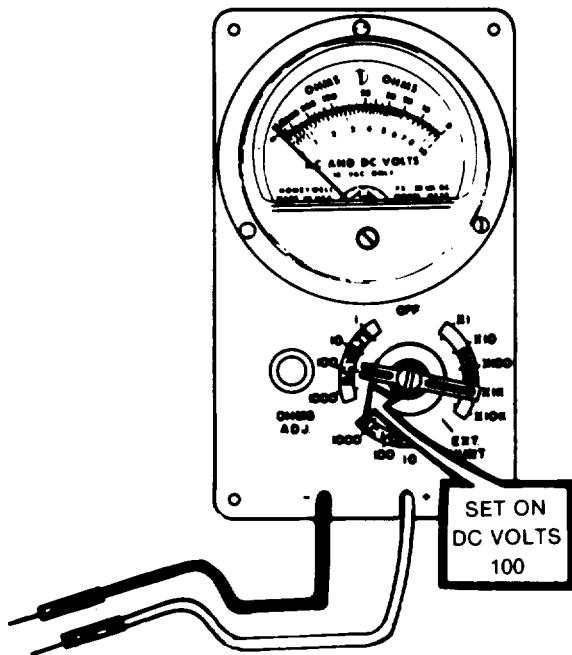

TA099767

**Figure 4-11. Using AN/URM-105 to Measure DC Volts.**

(2) TS-352 B/U (Fig. 4-12).

(a) Set the FUNCTION switch to DIRECT.

(b) Put the black lead in the DC+/-AC/OHMS jack.

**NOTE**

**If measuring less than 10V DC, use the 10V jack. If measuring less than 2.5V DC, use the 2.5V jack.**

(c) To measure 12V DC, plug the red lead into the 50V jack on the left side of the meter.

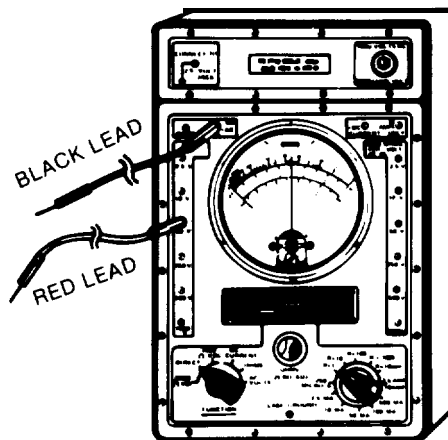

TA099768

**Figure 4-12. Using TS-352 B/U to Measure DC Volts.**

(3) Simpson 160 (Fig. 4-13).

**NOTE**

**If measuring less than 10V DC, set switch to the V/DC 10 position. If measuring less than 2.5V DC, set switch to the V/DC 2.5 position.**

(a) Set the polarity reversing switch to the + DC position.

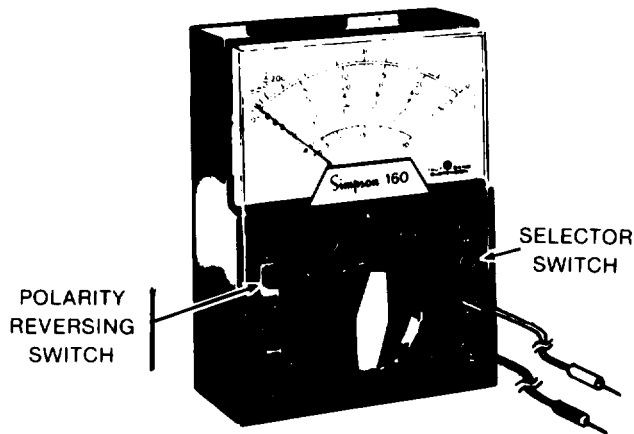

TA099769

**Figure 4-13. Using the Simpson 160 to Measure DC Volts.**

b. *Measuring DC Voltage.*

(1) First set up the meter (para 4-11).

(2) Connect the red probe to the positive (+) side of the circuit, and the black probe to the negative (-) side (fig. 4-14).

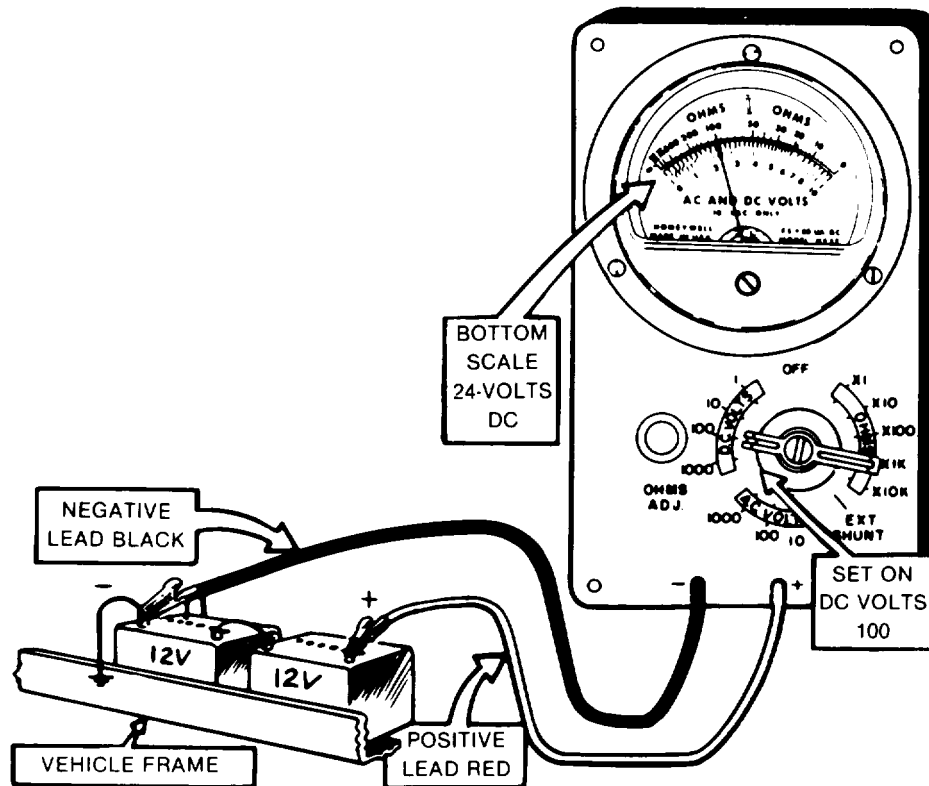

Figure 4-14. Measuring Battery Voltage.

TA099770

## Section VII. MAINTENANCE OF CHASSIS ELECTRICAL SYSTEM

## 4-12. Chassis Wiring

**WARNING**

**When troubleshooting an electrical malfunction or performing electrical maintenance, ALWAYS disconnect Intervehicular electrical cable from semitrailer, and negative battery cables at batteries. Failure to follow this warning may create a spark and explosion, resulting in serious injury or death to personnel.**

a. *General.* The chassis wiring of the semitrailer consists of one wiring harness, seven electrical lead assemblies, and one receptacle assembly. Refer to figures 4-15 and 4-16 for schematic diagram and wire connections of chassis electrical system. Wiring is as follows:

(1) *Receptacle Assembly.* The receptacle (fig. 4-16) is mounted on the left front side of the semitrailer. It connects the electrical system of the towing vehicle with that of the semitrailer. The main wiring harness of the semitrailer connects to the receptacle.

(2) *Wiring Harness.* This harness (fig. 4-16) runs the entire length of the semitrailer through conduit, the left rear composite light box, to the right rear composite light box. It connects to various leads which in turn connect to the lights on the semitrailer.

(3) *Rear Triple Marker Light Lead Assembly.* This lead (fig. 4-16) is threaded from the triple marker box through conduit to the left composite light box. There it connects to one of six leads of the connector lead assembly.

(4) *Right Front Marker Light Lead.* This lead (fig. 4-16) is threaded from the right front marker box through conduit to the left side of the semitrailer. There it connects into the receptacle wiring, the wiring harness and lead from the left front marker light.

(5) *Left Front Marker Light Lead Assembly.* This lead (fig. 4-16) connects to the left front marker light and to the right front marker light lead.

(6) *Right Side Marker Light Lead Assembly.* This lead (fig. 4-16) is threaded from the right center marker light box through conduit to the left center marker light box. There it connects to the wiring harness and to the left center marker light.

(7) *Right Rear Composite Light Lead Assembly.* This lead (fig. 4-16) is located in the right rear composite

composite light.

(8) *Left Rear Composite Light Lead Assembly.* This lead (fig. 4-16) is located in the left rear composite light box. It connects to the wiring harness in two places and to the left composite light.

(9) *Connector Lead Assembly.* This lead (fig. 4-16) is located in the left rear composite light box. It is made up of six different leads, of which two connect to left rear marker lights, two to the wiring harness, one to triple marker light lead, and one to left composite light.

b. *Repair.* Most of the wiring can be repaired without removing the harness and leads from the semitrailer.

(1) Clean end of harness leads with a damp cloth.

(2) Check ends of wire harness for frayed insulation and broken wires. Tape or replace frayed wires.

(3) Inspect wires for bent, broken, or missing terminals. Replace missing or damaged terminals.

c. *Replacement of Chassis Wiring.*

(1) *Composite Light and Connector Lead Assemblies Replacement.*

(a) Remove six screws that secure composite light box cover (fig. 4-23) to the light box. Remove cover and gasket.

(b) Start removing the old lead terminals one connection at a time. As each lead terminal is removed, connect the correct lead terminal of the replacement lead before removing the next one. Continue this process until the old lead is removed and the new one is completely connected into the circuit.

(c) Replace composite light cover and gasket. Secure with six screws.

(d) Test operation of lights.

(2) *Triple Marker Light Lead Assembly Replacement.*

(a) Remove six screws that secure composite light box cover (fig. 4-23) to the light box. Remove cover and gasket.

(b) In the composite light box, locate the lead that comes from the triple marker box (fig. 4-20). Disconnect this wire from the connector lead assembly (fig. 4-16). Cut the terminal from the lead.



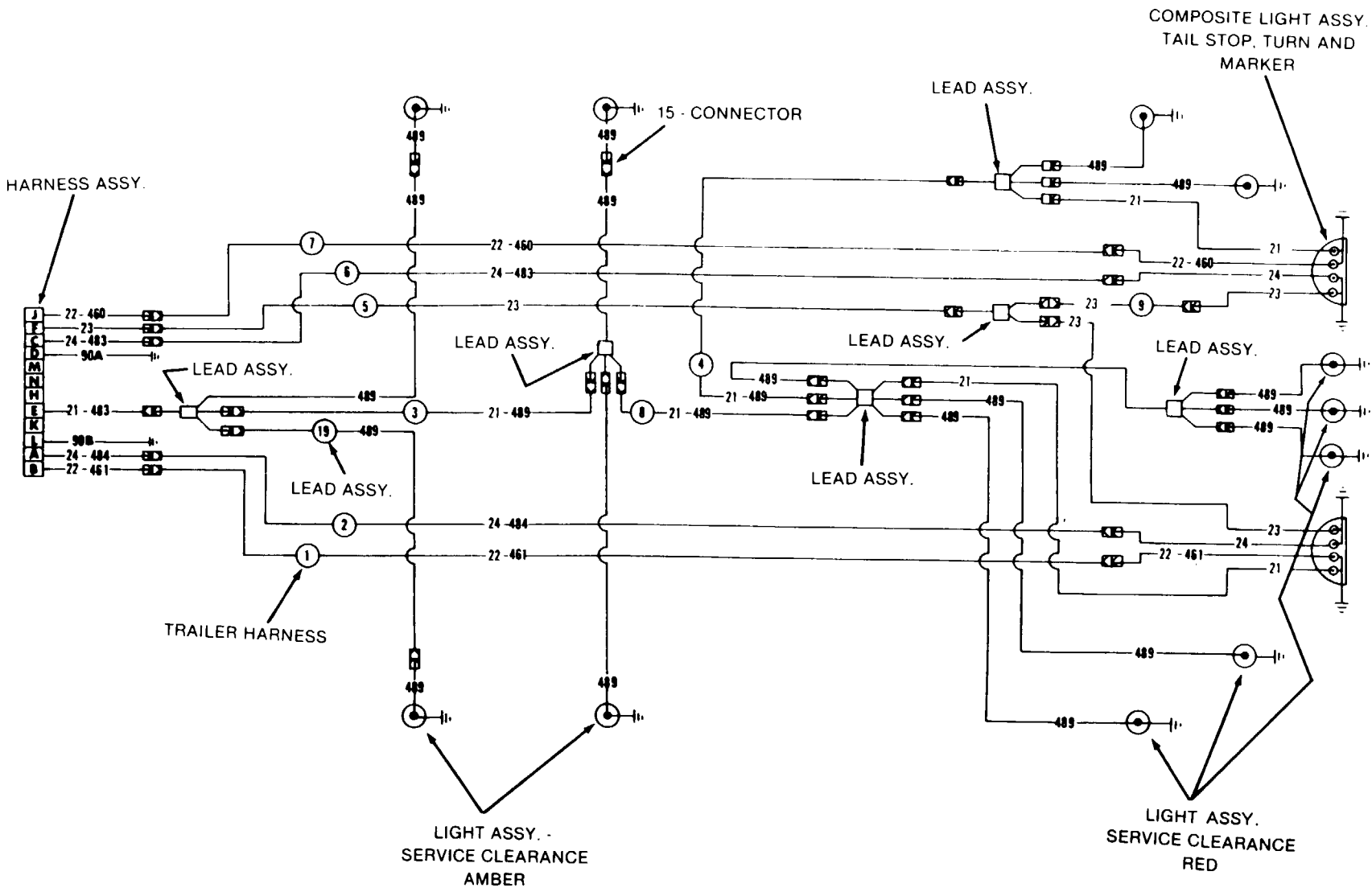

Figure 4-15. Chassis Wiring Diagram.

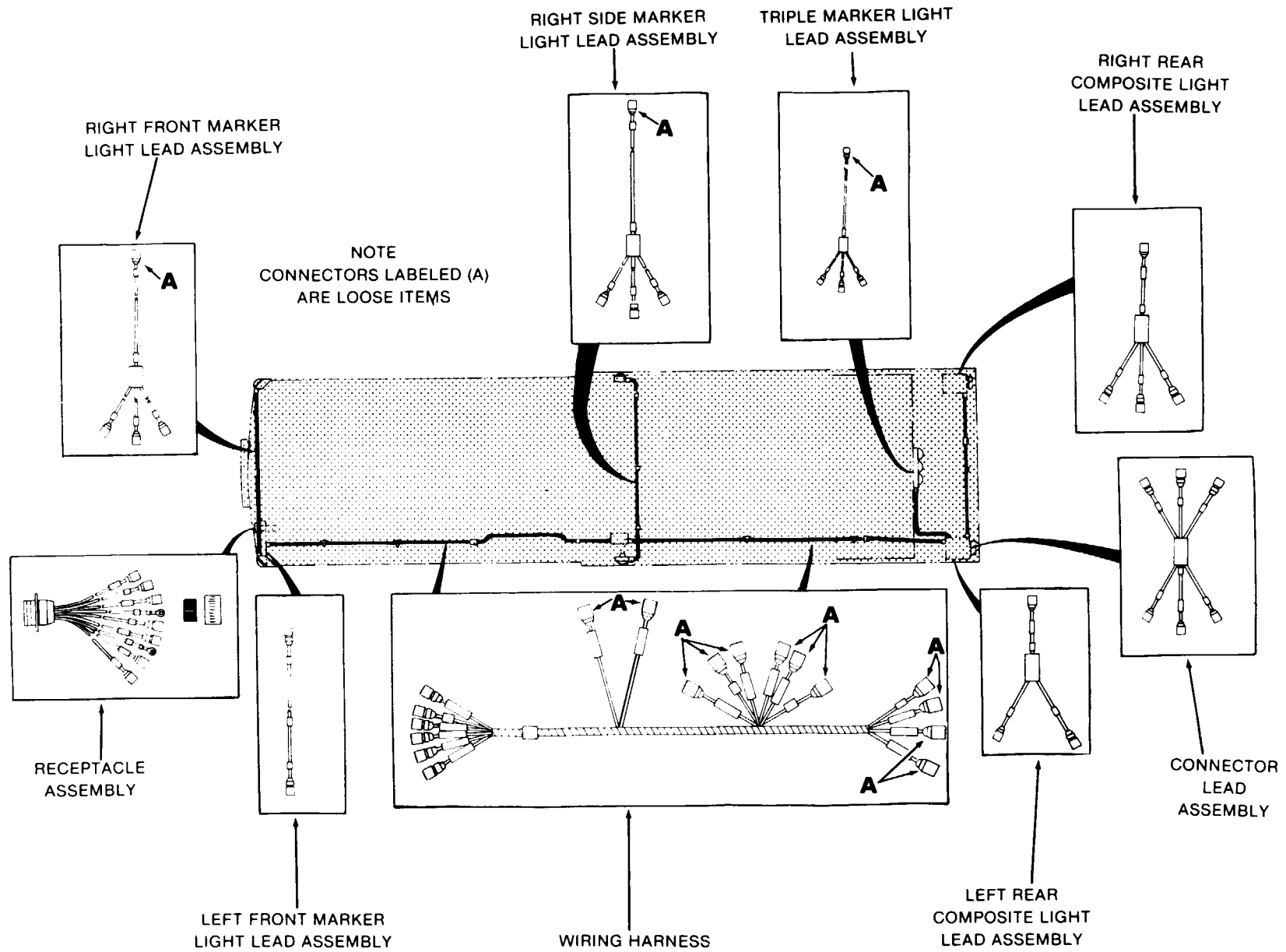

Figure 4-16. Wiring Harness and Electrical Lead Installation.

TA099772

(c) Remove the three marker lights para 4-15) from the triple marker box, but do not remove the washer and shell from the light leads.

(d) Pull old wire lead through conduit and out through one of the openings in the triple marker box.

(e) Starting at left composite light box, thread a lacing wire through conduit into triple light box. Attach lacing wire to lead, and pull lead through conduit into composite light box.

(f) Install new terminal onto lead. Connect triple marker light lead assembly to connector lead assembly (fig. 4-16).

(g) Replace composite light box cover and gasket. Secure with six screws.

(h) Connect the marker light leads to the triple marker light lead assembly.

(i) Replace triple marker lights (para 4-15).

(j) Test operation of lights.

(3) *Right Side Marker Light Lead Assembly Replacement.*

(a) Remove four screws that secure right marker light box cover (fig. 4-22) to the light box.

(b) Disconnect the marker light lead from the right center marker light lead assembly, then remove the cover and gasket.

(c) Cut the terminal from the marker light lead assembly.

(d) Remove the four screws that secure left side marker light box cover to the light box. Remove cover and gasket.

(e) Disconnect the marker light lead and remove gasket and cover.

(f) Disconnect the marker light lead assembly from the two wire harness leads.

(g) Pull the old marker light lead assembly through the conduit and out the left marker light box.

(h) Thread a lacing wire through conduit from one light box to the other. Attach lead assembly to lacing wire and pull the lead into the right marker box.

(i) Install new terminal onto the lead assembly.

(j) Connect right center marker light lead to the lead assembly. Replace gasket and cover. Secure with four screws.

(k) In the left marker box, connect the two harness leads (No. 21-489) to the new lead assembly. Connect the left marker light lead (No. 489) to the lead assembly. Replace gasket and cover. Secure with four screws.

(l) Test operation of lights.

(4) *Front Marker Light Lead Assemblies Replacement.*

(a) Remove both front marker light box covers and gaskets (fig. 4-21) by removing eight screws from each box cover and disconnecting the marker light electrical lead (No. 489).

(b) Remove six screws from the front electrical access cover (fig. 4-17). Remove cover and gasket.

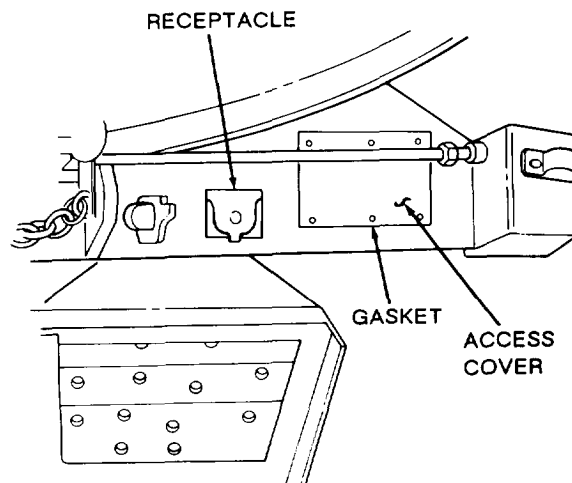

TA502342

**Figure 4-17. Front Access Cover**

(c) From inside electrical access hole, disconnect the left marker light lead assembly from the right marker light lead assembly. Disconnect right marker light lead assembly from receptacle wire lead (No. 21-489) and wire harness lead (No. 21-489).

(d) Cut the terminal from the right marker light lead assembly in the right marker box.

(e) From inside the left marker light box, pull the old right marker light lead assembly from the conduit.

(f) Starting at the right marker light box, thread a lacing wire through the conduit. Attach the lead assembly to the lacing wire, and pull the lead into right marker box.

(g) Install new terminal onto the lead assembly.

(h) Place the three ends of the lead assembly in the left marker box into the access hole.

(i) Connect the right marker light lead to the lead assembly. Replace the gasket and cover (fig. 4-21). Secure with eight screws.

(j) Through the front access hole, connect the left marker light lead assembly (No. 489) to the right marker light lead assembly. Connect the other two leads (No. 21-489) to the receptacle lead (No. 21-489) and the wire harness lead (No. 21-489).

(k) Replace the gasket and the front access cover by securing with six screws (fig. 4-17).

(l) Connect the left marker light lead (No. 489) to the lead assembly. Replace the receptacle box cover and gasket by securing with eight screws.

(m) Test operation of lights.

(5) *Wiring Harness Replacement.*

**NOTE**

**The terminals must be removed to pull harness through the conduit.**

(a) One at a time, remove each marker light box cover and gasket on the semitrailer's left side, then composite light box cover and gaskets. Disconnect all wiring harness leads and cut the terminals from the wiring harness leads.

(b) Pull the portion of wiring harness that runs across rear of the semitrailer out through the left rear composite light box.

(c) Remove the front access cover (fig. 4-17) and disconnect all wire harness leads from the receptacle and marker light leads.

(d) Pull the wiring harness out through the front access hole.

**NOTE**

**As harness is being pulled into conduit, coat harness with a silicon lubricant or mild soap solution. Do not coat entire harness at one time.**

(e) Starting at left rear composite light box, thread a lacing wire through conduit and out the front access hole. Attach lacing wire to new harness, then pull harness through conduit and out the composite light box.

(f) Disconnect lacing wire and thread it through right composite light box, conduit, and out left composite light box. Attach lacing wire to wire harness and pull wiring harness out right composite light box.

(g) In each light box, pull wiring harness leads out of conduit and into light box. Install new terminals onto each wiring harness lead.

(h) Connect all light leads to wiring harness leads (fig. 4-15).

(i) Replace all light box covers and gaskets.

(j) In the front access hole, connect harness leads to receptacle and marker light leads.

(k) Replace front access hole cover and gasket. Secure with six screws.

(l) Test operation of semitrailer lights.

(6) *Receptacle Assembly Replacement.*

(a) Remove six screws from front access cover (fig. 4-17). Remove cover and gasket.

(b) Inside access hole, disconnect all electrical leads from the receptacle electrical leads. Remove screw that fastens the receptacle ground leads to the semitrailer.

(c) Remove four screws and lockwashers from the receptacle mounting plate, and remove the receptacle and-gasket (fig. 4-18).

(d) To install receptacle, reverse steps (a) through (c).

(e) Test operation of semitrailer lights.

#### 4-14. Marker Lights

##### **WARNING**

When troubleshooting an electrical malfunction or performing electrical maintenance, **ALWAYS** disconnect Intervehicular electrical cable from semitrailer, and negative battery cables at batteries. Failure to follow this warning may create a spark and explosion, resulting in serious injury or death to personnel.

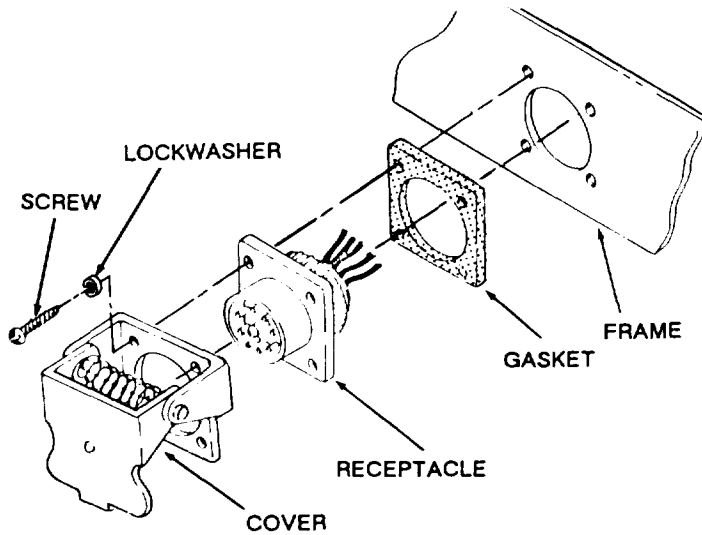

TA502343

Figure 4-18. Receptacle Installation.

#### 4-13. Conduit for Chassis Wiring

##### **WARNING**

When troubleshooting an electrical malfunction or performing electrical maintenance, **ALWAYS** disconnect Intervehicular electrical cable from semitrailer, and negative battery cables at batteries. Failure to follow this warning may create a spark and explosion, resulting in serious injury or death to personnel.

*a. Removal.* Wiring conduit should only be removed when repairs are warranted. Remove wiring harness and electrical leads as needed (para 4-12). Use figure 4-19 as reference when removing conduit. Where conduit passes under clips, bend these clips back far enough to remove conduit, but do not break clips off. Should enough of these clips break off to hamper installation of conduit, contact direct support maintenance to weld on new clips.

*b. Installation.* Use figure 4-19 as reference to install new conduit.

*a. Replacement of Lamps.* The front, center, and rear marker lights (figs. 4-20 through 4-23) are constructed the same, except that the front and side marker lights have an amber lens while the rear marker lights have a red lens.

(1) Remove two screws (fig. 4-24) that hold lens housing to body. Remove lens housing.

(2) Press down on lamp and turn counterclockwise to remove lamp.

(3) Install new lamp.

(4) Replace lens housing. Secure with two screws.

*b. Removal.*

(1) Remove two screws (fig. 4-24) that secure lens housing to body. Remove lens housing.

(2) Remove four screws that fasten marker light body to plate. Be careful not to lose the four spacer washers between gasket and body.

(3) Disconnect marker light lead and remove marker light.

(4) Remove washer and shell from marker light lead.

*c. Installation.*

(1) Replace washer and shell on marker light lead.

(2) Connect marker light lead to chassis wiring.

(3) Attach marker light body to trailer with four screws. Be sure spacer washers are installed between gasket and body.

(4) Install lamp if needed, and replace lens housing by securing with two screws.

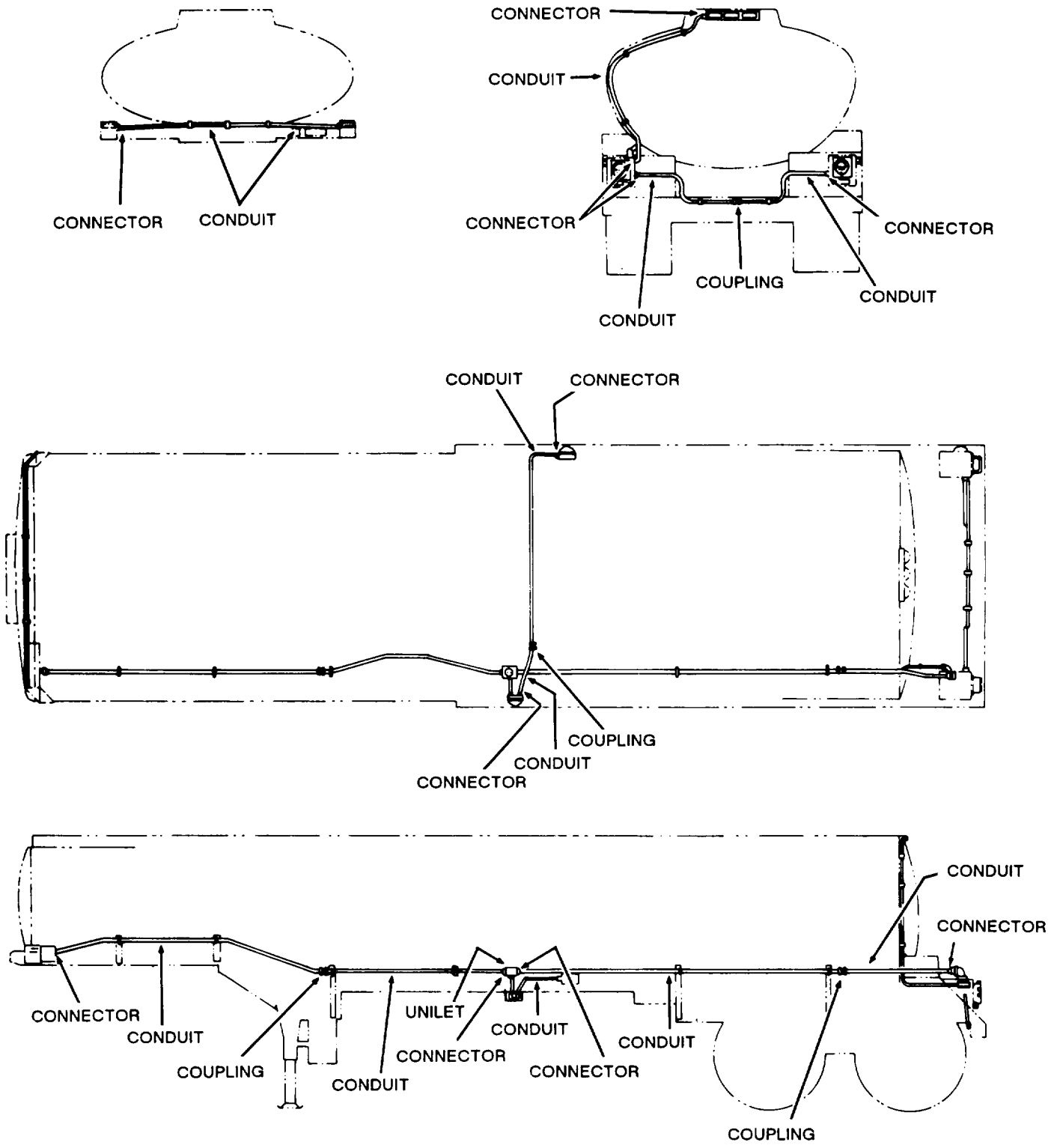
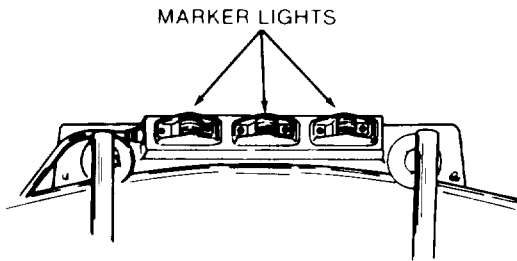
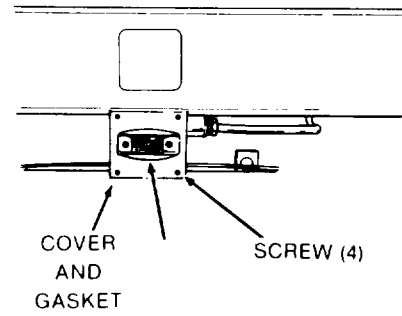

Figure 4-19. Chassis Wiring Conduit Installation.

TA099775



**Figure 4-20. Triple Marker Box** TA099776



**Figure 4-22. Side Marker Box.** TA099778

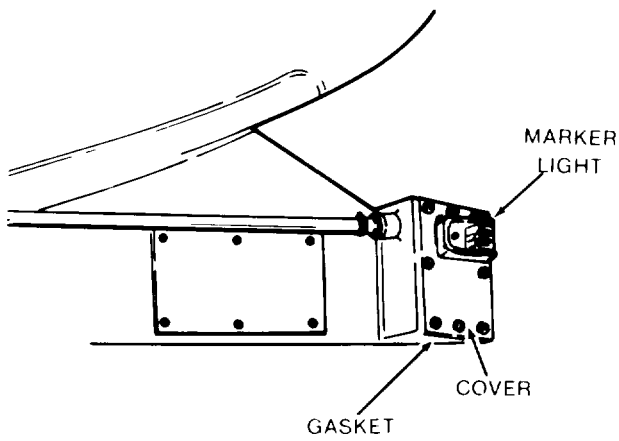

**Figure 4-21, Front Marker Box.** TA099777

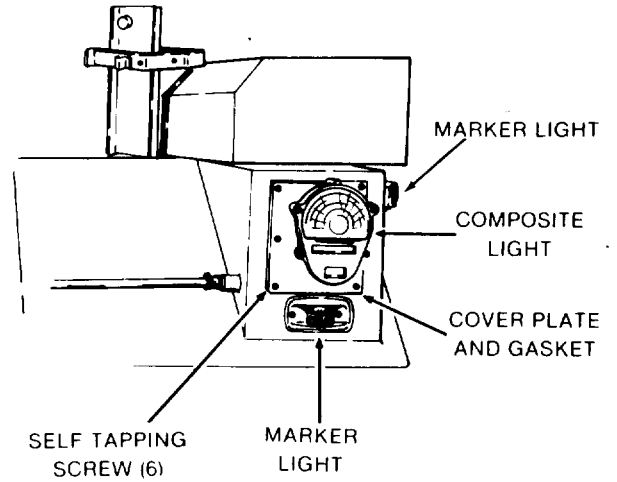

**Figure 4-23. Composite Light.** TA099779

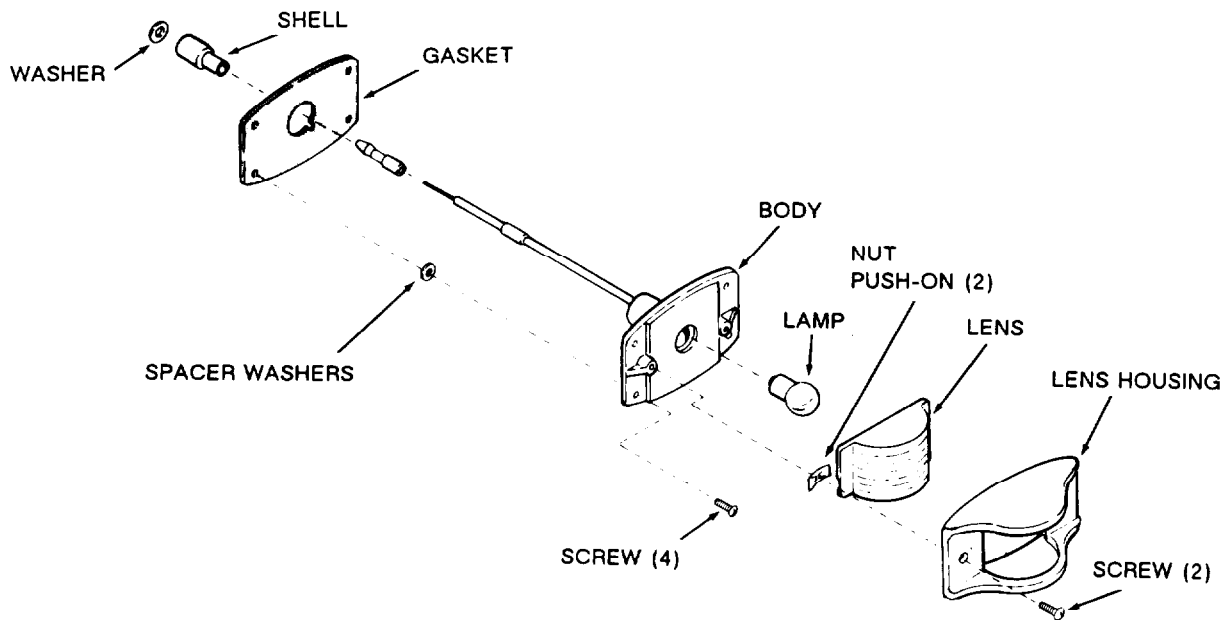

Figure 4-24. Exploded View of Marker Light.

TA099780

4-15. Composite Tall Stop Lights

**WARNING**

**When troubleshooting an electrical malfunction or performing electrical maintenance, ALWAYS disconnect intervehicular electrical cable from semitrailer, and negative battery cables at batteries. Failure to follow this warning may create a spark and explosion, resulting in serious injury or death to personnel.**

a. Lamp or Lens Replacement.

- (1) Loosen six captive screws (fig. 4-25) which fasten door and lens to body.
- (2) Remove door and lens find preformed packing.
- (3) Remove defective lamp and install a new lamp.
- (4) Inspect preformed packing and replace if damaged.

- (5) Inspect door and lens assembly. If damaged, replace. Secure door and lens assembly to body assembly with six screws.

b. Removal.

- (1) Loosen six self-tapping screws (fig. 4-23) that fasten cover plate to semitrailer. Remove cover plate and gasket.
- (2) Disconnect light wires from harness.
- (3) Remove the two capscrews and lockwashers (fig. 4-25) that attach composite light to plate.

- (4) Remove composite light and gasket.

c. Installation.

- (1) Fasten composite light and gasket to cover plate with two lockwashers and capscrews (fig. 4-25).
- (2) Connect light wires to the harness.
- (3) Install cover plate and secure with six self-tapping screws.



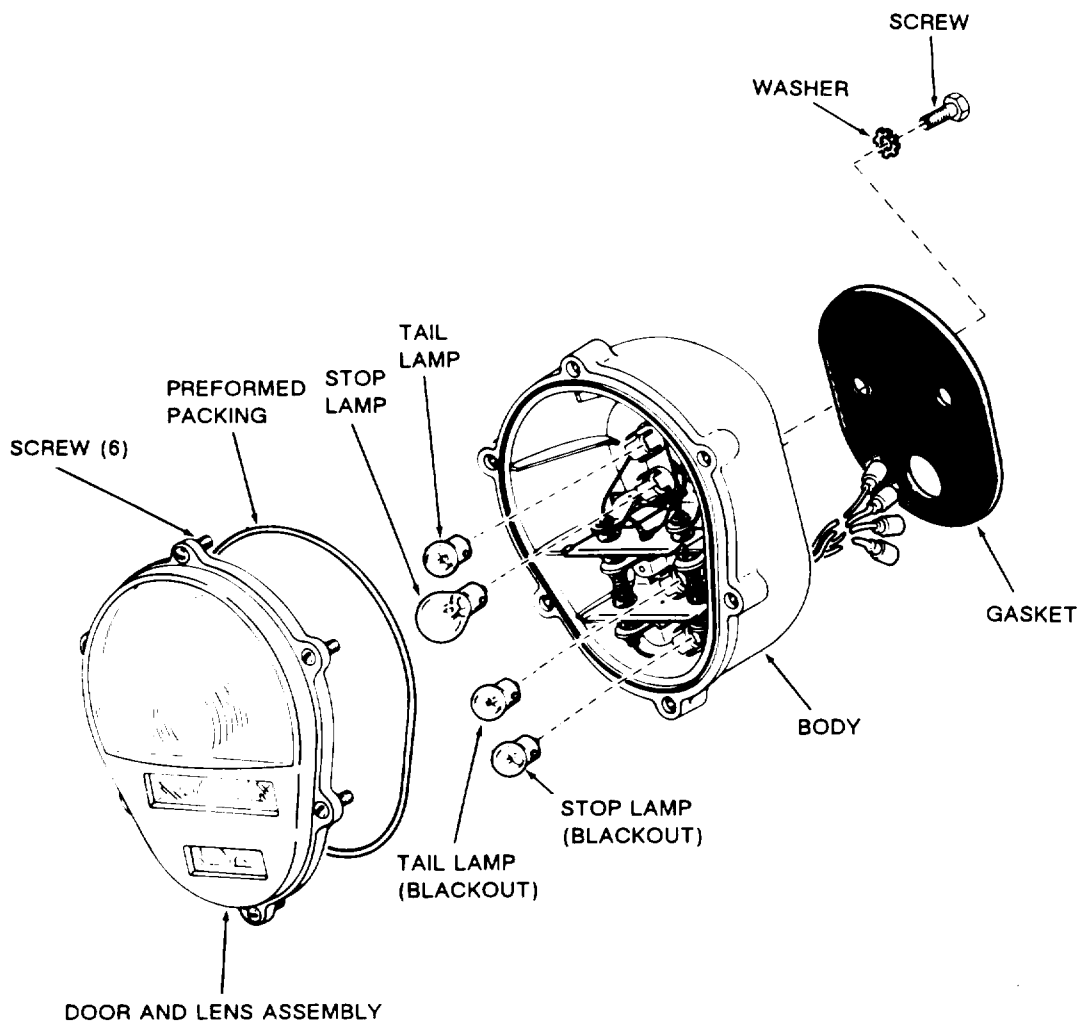

Figure 4-25. Exploded View of Composite Light.

TA099781

Section VIII. MAINTENANCE OF ENGINE ELECTRICAL WIRING

4-16. Engine Wiring

**WARNING**

**When troubleshooting an electrical malfunction or performing electrical maintenance, ALWAYS disconnect intervehicular electrical cable from semitrailer, and negative battery cables at batteries. Failure to follow this warn-**

**ing may create a spark and explosion, resulting in serious injury or death to personnel.**

*a. General.* The engine wiring consists of seventeen different leads. Each lead has its origin at either the engine junction box or the buss bar (figs. 4-26 and 4-27). Each of these leads is replaceable as an assembly.

*b. Replacement.* Refer to figures 4-26 through 4-29 as a guide in removing any engine wiring. Repair or remove and replace any wire that is cut, is frayed, or has broken terminals.

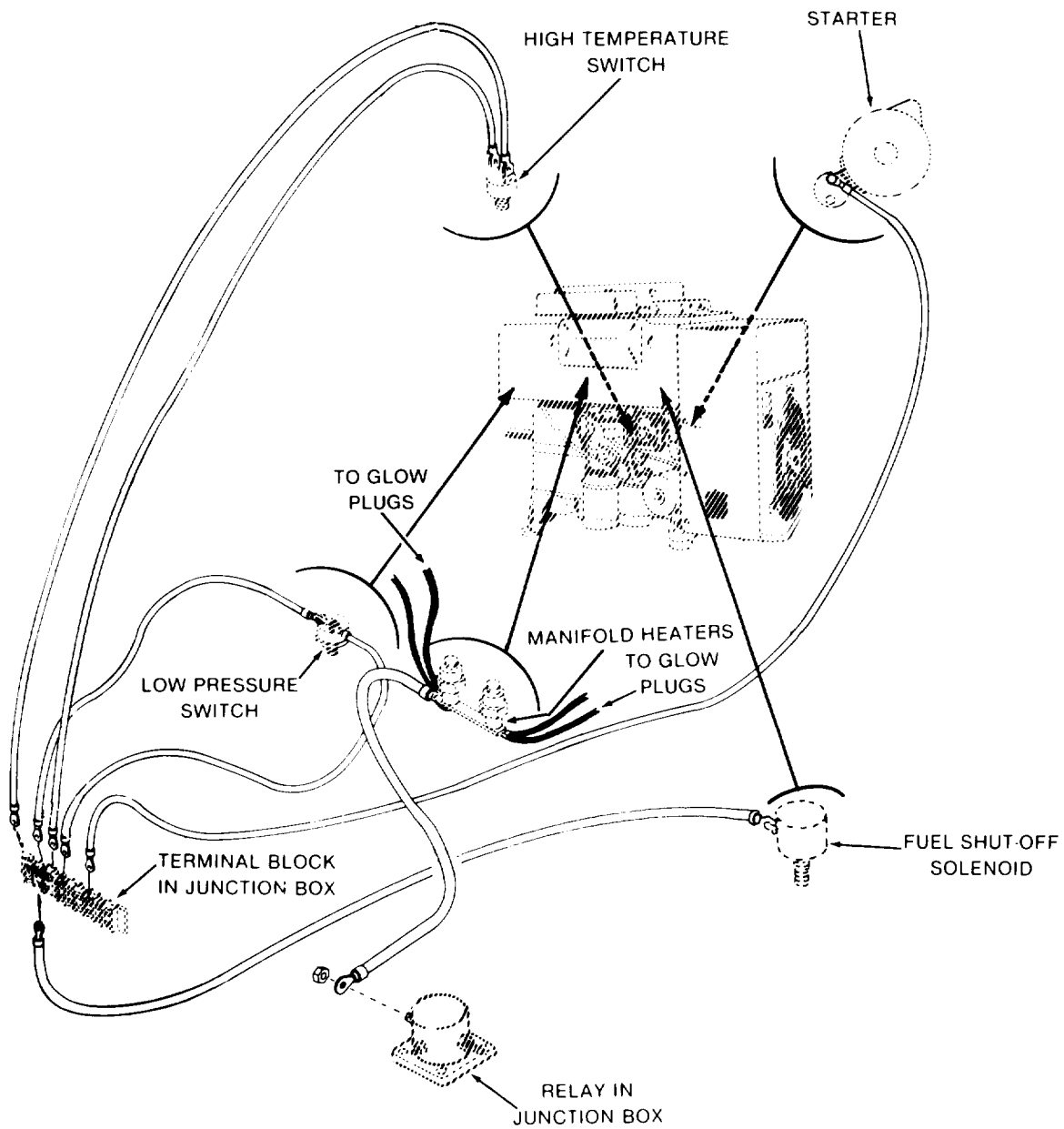

TA099782

**Figure 4-26. Starter High Temperature Switch, Low Pressure Switch, Fuel Shut-off Solenoid, and Manifold Heater Wiring.**

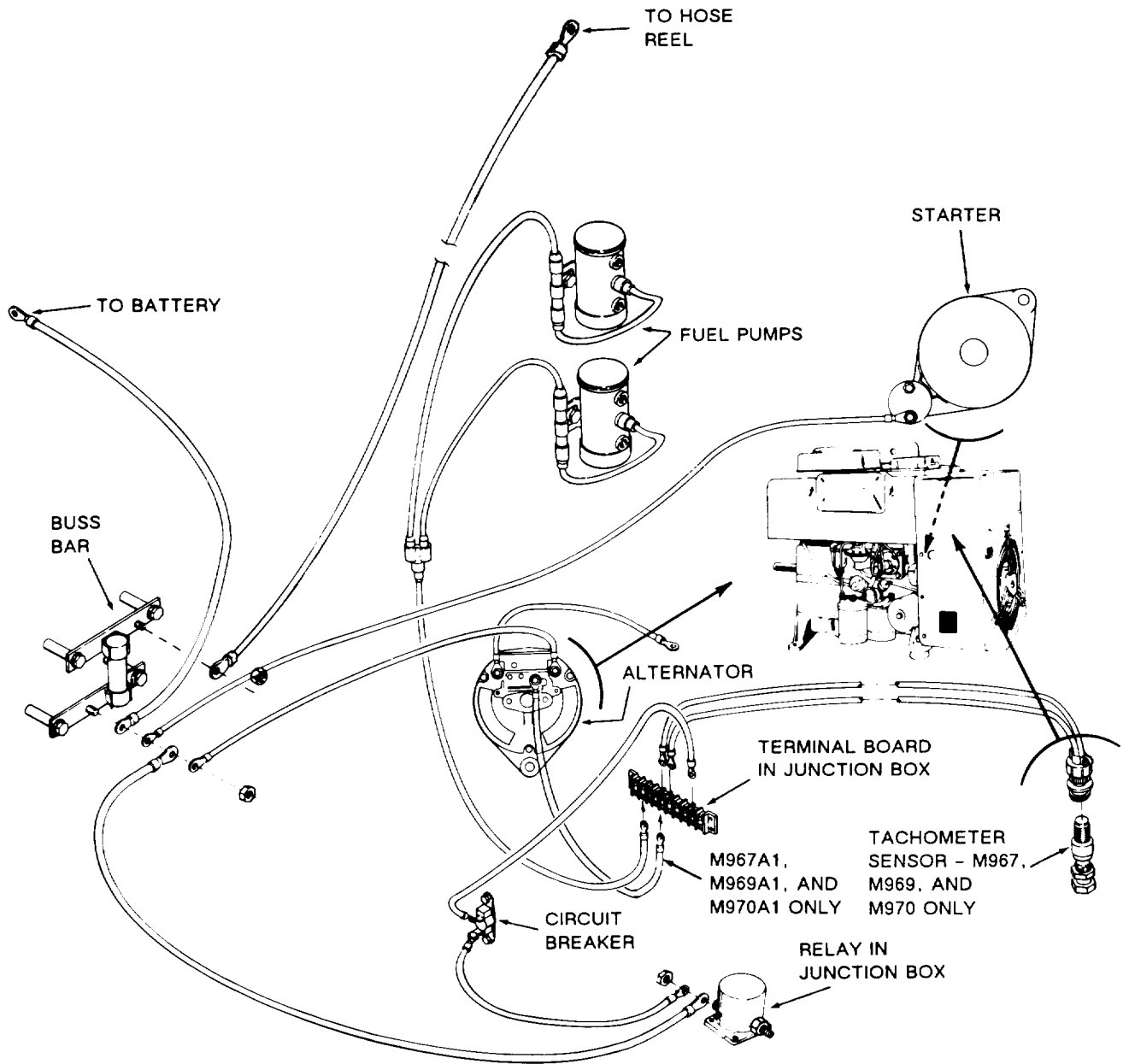

TA502344

Figure 4-27. Alternator Buss Bar Circuit Breaker Starter Fuel Pumps, and Tachometer Sensor Wiring.

Figure 4-28. Engine Wiring Schematic (M967, M969, and M970).

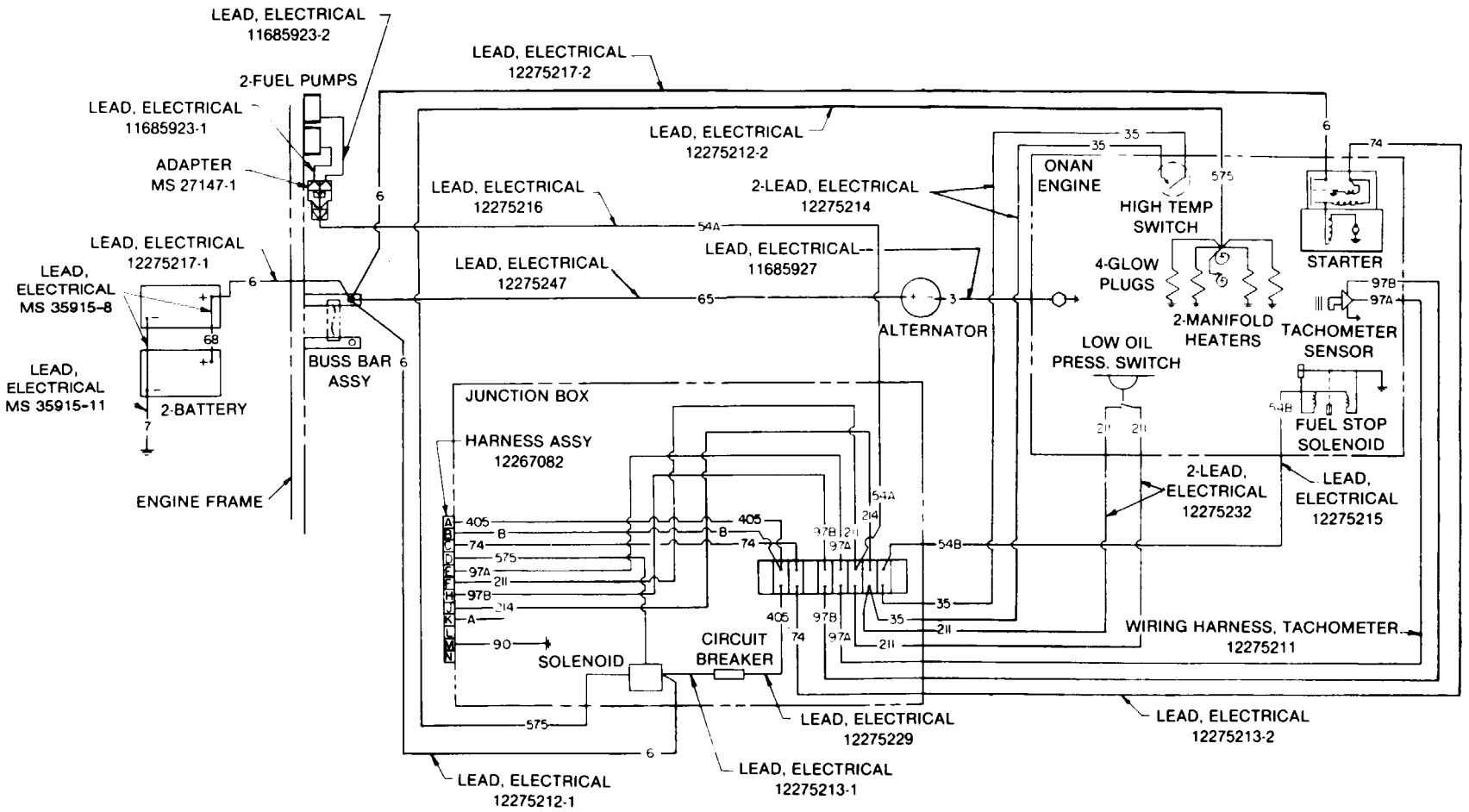

TA099784

Figure 4-29. Engine Wiring Schematic (M967A1, M969A1, and M970A1).

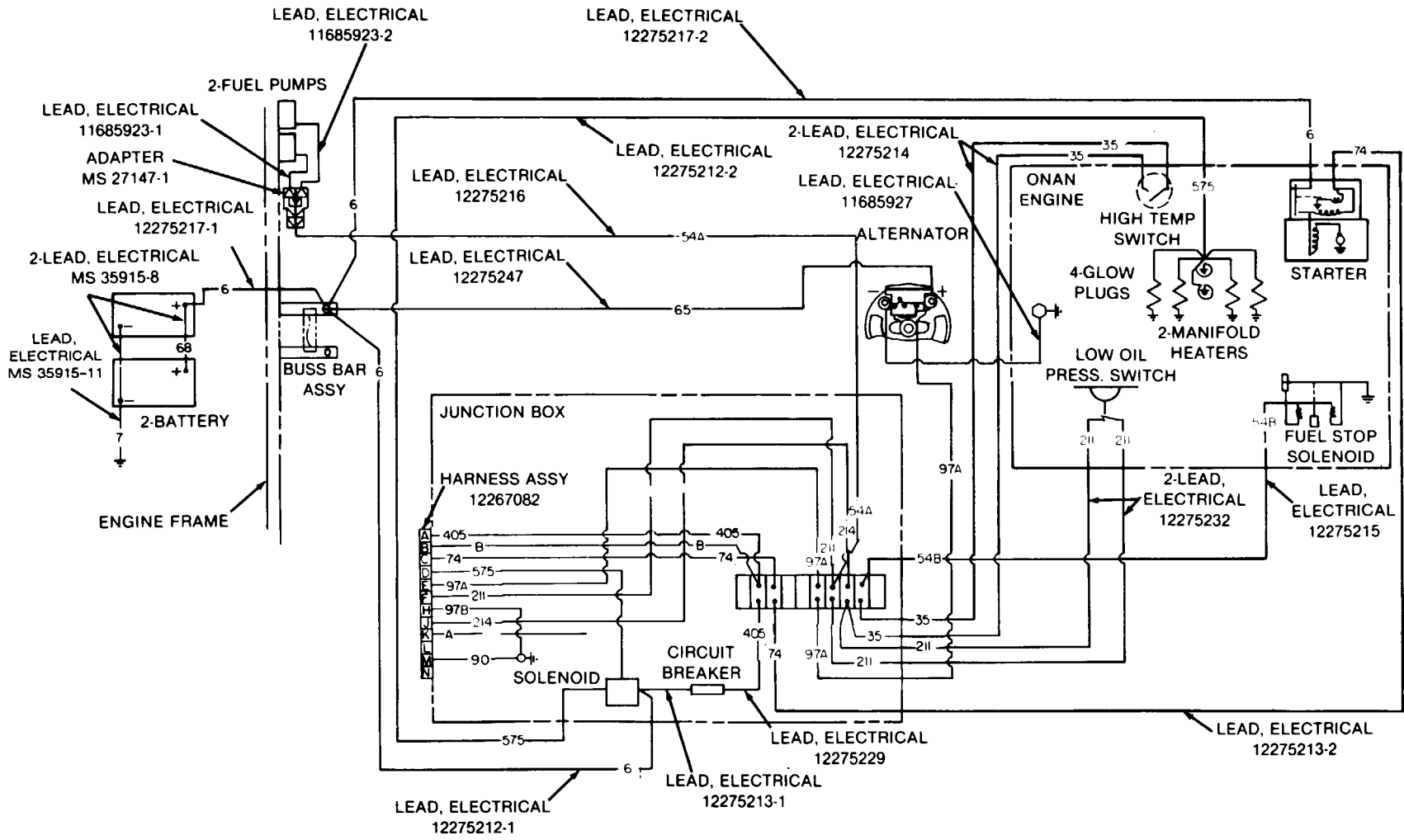

4-17. Circuit Breaker

**WARNING**

**When troubleshooting an electrical malfunction or performing electrical maintenance, ALWAYS disconnect intervehicular electrical cable from semitrailer, and negative battery cables at batteries. Failure to follow this warning may create a spark and explosion, resulting in serious injury or death to personnel.**

a. *Removal.*

- (1) Disconnect negative battery cable from battery (fig. 4-37).
- (2) Loosen engine junction box clamp screws and open cover.
- (3) Disconnect all leads from preheater solenoid and circuit breaker (fig. 4-30).
- (4) Disconnect lead No. 54 (fig. 4-30) that goes to fuel pumps from terminal strip.

(5) Loosen three cable connectors (fig. 4-30) on side of junction box.

(6) Pull the two large leads through the connectors until they are almost removed from the junction box.

(7) Remove four screws (6, fig. 4-31) and washers (7) that secure mounting plate to control panel.

(8) Tilt mounting plate (8) for access to circuit breaker mounting screws (13).

(9) Remove the two screws (13) and circuit breaker (12).

b. *Installation.*

(1) Install circuit breaker to plate with two screws (13, fig. 4-31).

(2) Fasten mounting plate to control panel with four screws (6) and washers (7). Ground lead is to be installed with upper left screw.

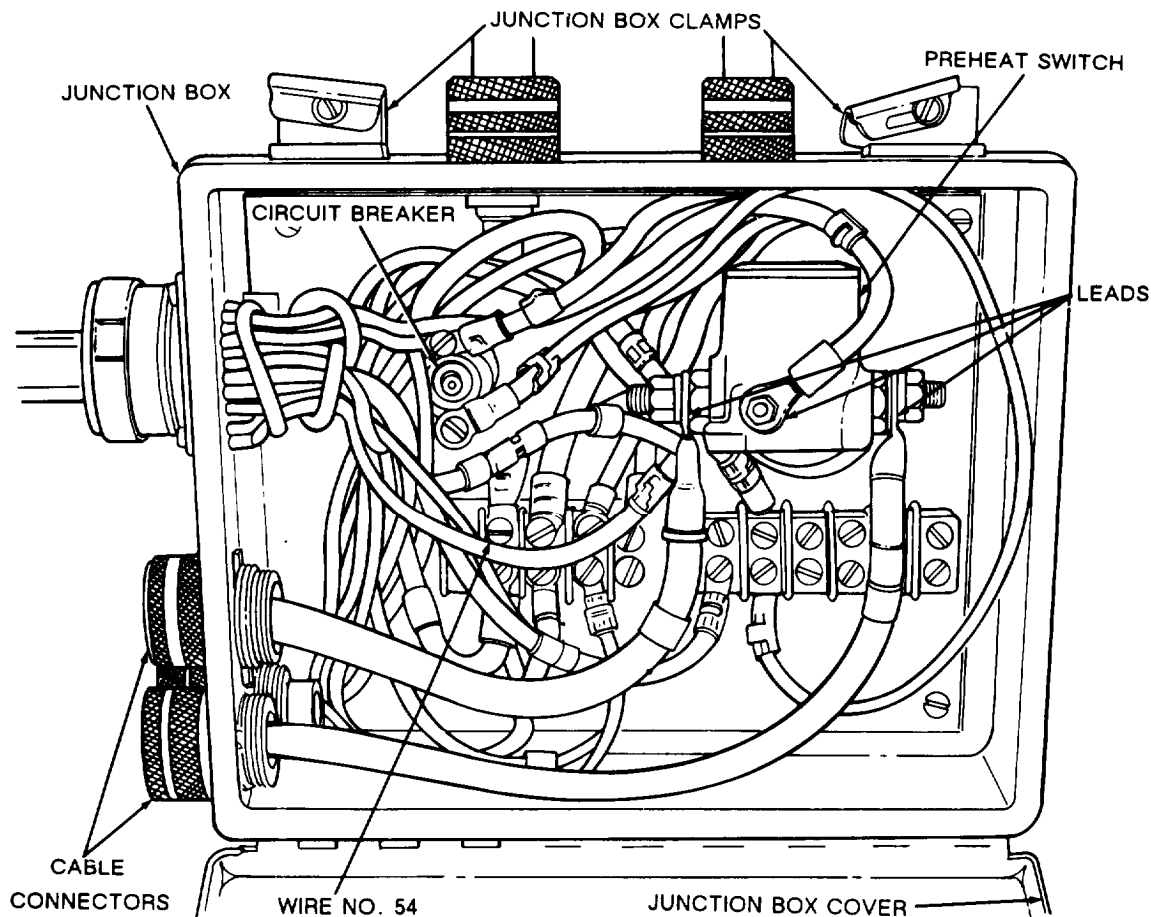
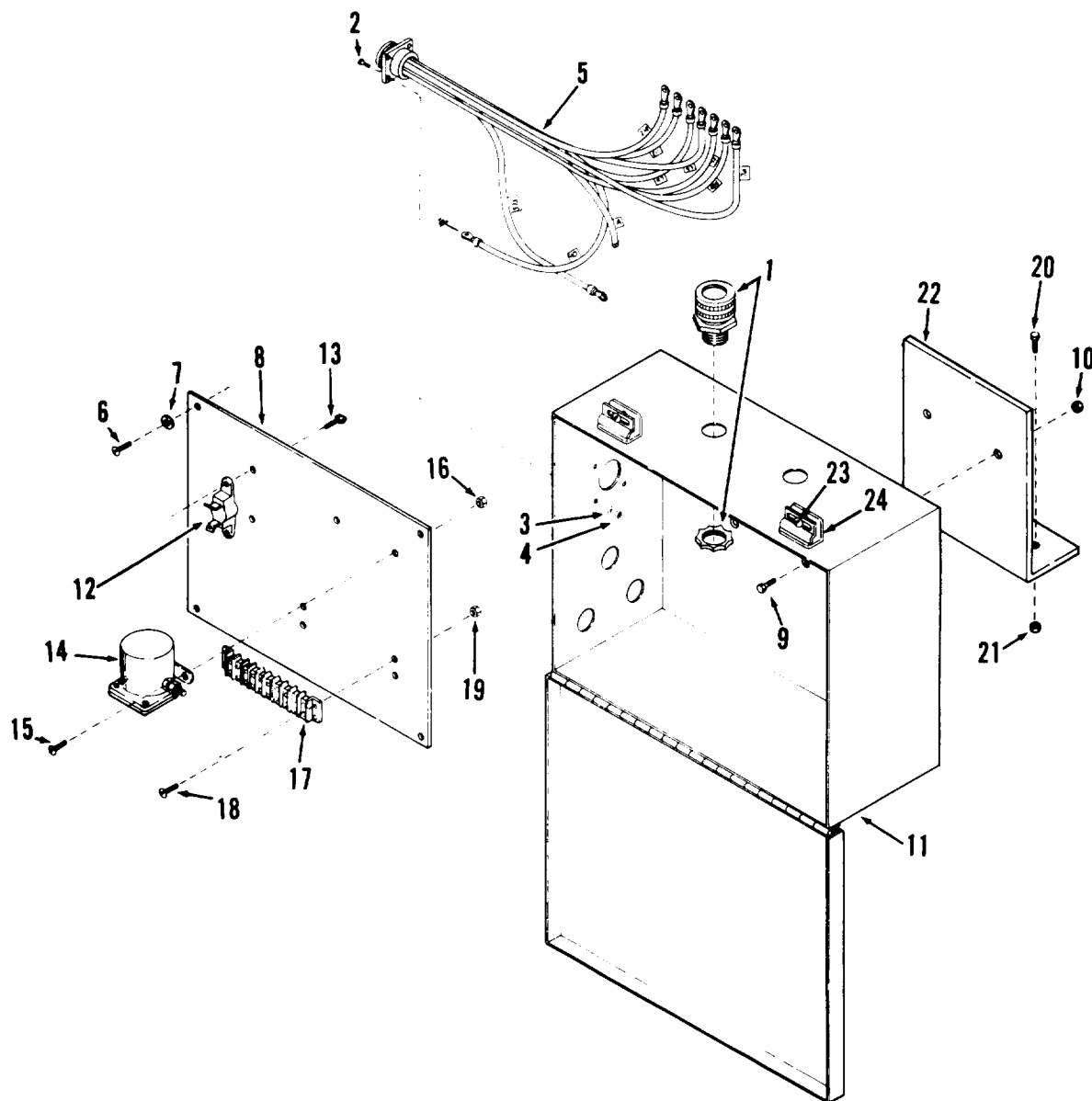

Figure 4-30. Location of Circuit Breaker and Preheater Solenoid in Junction Box.

TA502346



- |                        |                        |
|------------------------|------------------------|
| 1. Cable connector (5) | 13. Screw (2)          |
| 2. Capscrew (4)        | 14. Preheater solenoid |
| 3. Lockwasher (4)      | 15. Screw (2)          |
| 4. Nut (4)             | 16. Nut (2)            |
| 5. Wiring harness      | 17. Terminal strip     |
| 6. Screw (4)           | 18. Screw (2)          |
| 7. Washer (4)          | 19. Nut (2)            |
| 8. Mounting plate      | 20. Capscrew (2)       |
| 9. Capscrew (2)        | 21. Nut (2)            |
| 10. Nut (2)            | 22. Mounting bracket   |
| 11. Junction box       | 23. Screw (2)          |
| 12. Circuit breaker    | 24. Clip (2)           |

**Figure 4-31. Disassembled Engine Junction Box.**

TA502288

(3) Connect leads to circuit breaker and preheater solenoid.

(4) Connect lead No. 54 (fig. 4-30) to terminal strip.

(5) Tighten cable connectors on side of junction box.

(6) Close junction box cover and tighten clamps.

(7) Connect negative battery cable to battery (fig. 4-37).

#### 4-18. Engine Preheater Solenoid

##### **WARNING**

**When troubleshooting an electrical malfunction or performing electrical maintenance, ALWAYS disconnect intervehicular electrical cable from semitrailer, and negative battery cables at batteries. Failure to follow this warning may create a spark and explosion, resulting in serious injury or death to personnel.**

##### *a. Removal.*

(1) Disconnect negative battery cable from battery (fig. 4-37).

(2) Loosen engine junction box clamps and open cover.

(3) Disconnect all leads from preheater solenoid and circuit breaker (fig. 4-30).

(4) Disconnect lead No. 54 (fig. 4-30) that goes to fuel pumps from terminal strip.

(5) Loosen cable connectors (fig. 4-30) on side of junction box.

(6) Pull the two large leads through the connectors until they are almost removed from the junction box.

(7) Remove four screws (6, fig. 4-31) and washers (7) that secure mounting plate to control panel.

(8) Tilt mounting plate (8) for access to solenoid mounting screws.

(9) Remove the two screws (15), nuts (16), and preheater solenoid (14).

##### *b. Installation.*

(1) Install solenoid (14, fig. 4-31) to mounting plate with two screws (18) and nuts (19).

(2) Fasten mounting plate to control panel with four screws (6) and washers (7). Ground lead is to be installed with upper left screw.

(3) Connect leads to preheater solenoid (fig. 4-30).

(4) Connect lead No. 54 to terminal strip.

(5) Tighten cable connectors on side of junction box.

(6) Close junction box cover and tighten clamps.

(7) Connect negative battery cable to battery (fig. 4-37).

#### 4-19. Engine Junction Box

##### **WARNING**

**When troubleshooting an electrical malfunction or performing electrical maintenance, ALWAYS disconnect intervehicular electrical cable from semitrailer, and negative battery cables at batteries. Failure to follow this warning may create a spark and explosion, resulting in serious injury or death to personnel.**

##### *a. Removal.*

(1) Disconnect negative battery cable from battery (fig. 4-37).

(2) Loosen junction box cover screws and lower the cover.

(3) Tag all leads in junction box necessary for removal of cables to ensure proper installation when installing junction box.

(4) Disconnect all leads in junction box and remove completely.

(5) Remove four capscrews (2), lockwashers (3), and nuts (4). Remove wiring harness (5).

(6) Remove five cable connectors (1) by removing locking washers, and pull cable assemblies.

(7) Remove four screws (6) and washers (7). Remove mounting plate (8).

(8) Remove two capscrews (9) and nuts (10). Remove junction box (11).



(9) Remove circuit breaker (12), preheater solenoid (14), and terminal strip (17).

(10) If damaged, remove screw (23) and clip (24) from junction box (11).

*b. Installation (Fig. 4-31).*

(1) If removed, install clip (24) and screw (23) to junction box (11).

(2) Install circuit breaker (12) onto mounting plate (8) with two screws (13), preheater solenoid (14) with two screws (15) and nuts (16), and terminal strip (17) with two screws (18) and two nuts (19).

(3) Install junction box (11) on bracket (22) with two capscrews (9) and nuts (10).

(4) Install mounting plate (8) in junction box (11) and secure with four screws (6) and washers (7).

(5) Insert cable assemblies with connectors (1) in junction box holes and secure with cable connector locking washers.

(6) Install wiring harness (5), and secure with four capscrews (2), lockwashers (3), and nuts (4).

(7) Correctly connect all leads in the junction box in accordance with the tag designations. Remove tags.

(8) Close cover and secure with screws.

(9) Connect negative battery cable to battery (fig. 4-37).

**4-20. Manifold Heaters**

**WARNING**

**When troubleshooting an electrical malfunction or performing electrical maintenance, ALWAYS disconnect Intervehicular electrical cable from semitrailer, and negative battery cables at batteries. Failure to follow this warning may create a spark and explosion, resulting in serious Injury or death to personnel.**

*a. Inspection (Fig. 4-32).* Inspect manifold heaters for physical damage. Check that electrical leads to manifold heaters are clean and secure.

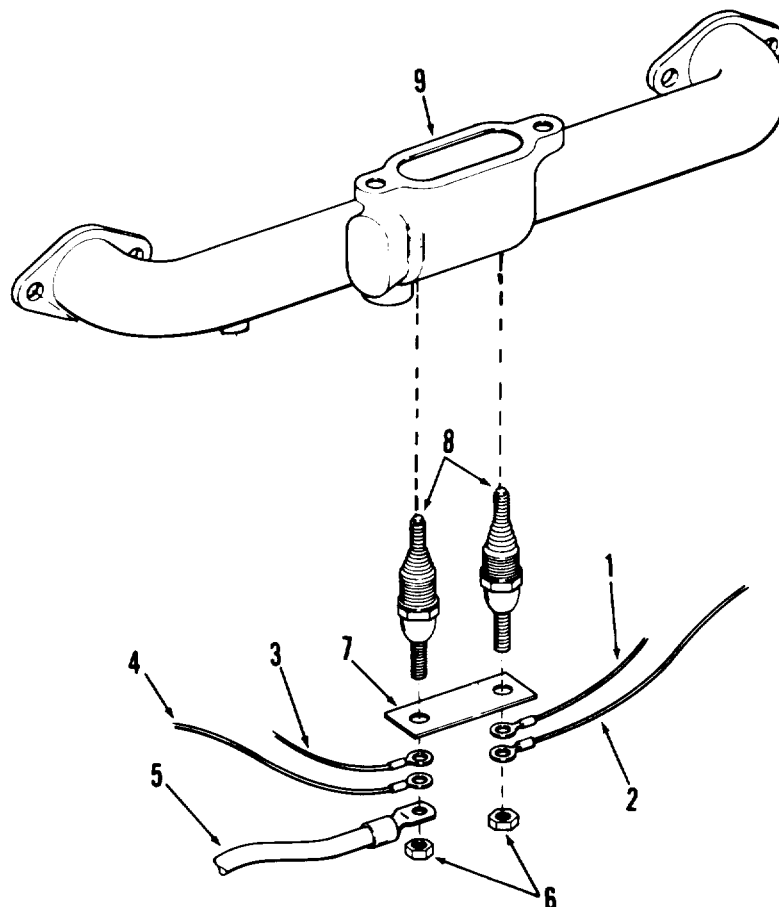

- 1. Lead
- 2. Lead
- 3. Lead
- 4. Lead
- 5. Lead
- 6. Nut (2)
- 7. Connecting bar
- 8. Manifold heaters
- 9. Manifold

**Figure 4-32. Manifold Heaters**

TA099787

**CAUTION**

**With preheater switch in the PREHEAT position, 12V DC is applied to manifold heaters. Do not handle manifold heaters with preheater switch in the PREHEAT position.**

*b. Test.* Remove electrical leads to manifold heaters. Use ohmmeter to test for continuity from terminal of manifold heater to ground. Open circuit indicates faulty manifold heater.

*c. Removal.*

(1) Disconnect negative battery cable from battery (fig. 4-37).

(2) Open engine door panel (fig. 4-101).

(3) Disconnect five electrical leads (1,2,3,4, and 5, fig. 4-32) from manifold heaters by removing nuts (6).

(4) Remove connecting bar (7).

(5) Unscrew manifold heaters (8) from air intake manifold (9).

*d. Installation.*

(1) Screw manifold heaters (8, fig. 4-32) into air intake manifold. Tighten to 10-15 lb.-ft.

(2) Reinstall connecting bar (7), electrical leads (1 through 5), and nuts (6) to manifold heaters.

(3) Close engine cover panel.

(4) Connect negative battery cable to battery (fig. 4-37).

**4-21. Glow Plugs**

**WARNING**

**When troubleshooting an electrical malfunction or performing electrical maintenance, ALWAYS disconnect Intervehicular electrical cable from semitrailer, and negative battery cables at batteries. Failure to follow this warning may create a spark and explosion, resulting in serious injury or death to personnel.**

*a. Inspection.* Inspect glow plugs (fig. 4-33) for physical damage. Check that electrical lead to glow plug is clean and tight. Check for leakage, indicated by oily residue, where glow plug enters cylinder head.

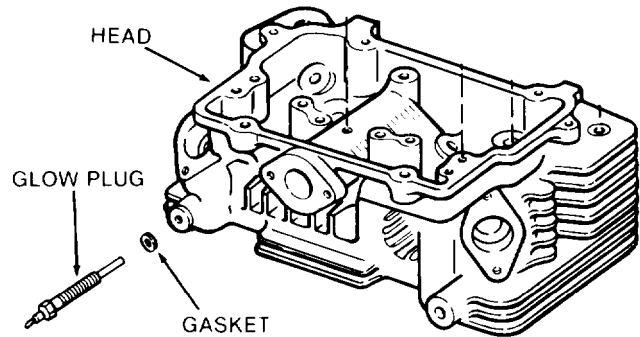

TA099788

**Figure 4-33. Glow Plugs.**

**CAUTION**

**With preheater switch in the PREHEAT position, 12V DC is applied to the glow plug body. Do not handle glow plug with preheater switch in the PREHEAT position.**

*b. Test.* Remove electrical lead to glow plug. Use ohmmeter to test for continuity from terminal of glow plug and ground. Open circuit indicates bad glow plug.

*c. Removal.* Disconnect negative battery cable at battery. Disconnect lead to glow plug. Unscrew glow plug and remove it from cylinder head. Remove gasket with a hooked wire, then replace.

*d. Installation.* If gasket has been removed, place new gasket over glow plug. Coat plug threads with anti-seize compound (item 6, Appendix E), and screw glow plug into cylinder head. Tighten glow plug to 10-15 lb.-ft. Connect electrical lead to plug. Connect negative battery lead to battery.

**4-22. High Temperature Switch, Oil Pressure Switch, and Fuel Stop Solenoid**

**WARNING**

**When troubleshooting an electrical malfunction or performing electrical maintenance, ALWAYS disconnect Intervehicular electrical cable from semitrailer, and negative battery cables at batteries. Failure to follow this warning may create a spark and explosion, resulting in serious injury or death to personnel.**

*a. General.*

(1) The high temperature switch (fig. 4-34) is mounted on the engine just below the exhaust manifold on

the side of the engine next to the tank. Its operating contacts are normally closed. If engine temperature rises above 240° F, the switch contacts open, de-energizing the fuel stop solenoid and stopping the engine. The switch closes again at about 195°F.

(2) The low oil pressure switch (fig. 4-35) is located behind the engine shroud door. The switch is normally open. As the engine is cranked over, the switch contacts close, completing the circuit to the fuel stop solenoid (fig. 4-36).

(3) If oil pressure drops below approximately 13 psi, the switch opens the fuel stop solenoid circuit and the engine will stop.

(4) If fuel flow from the tank stops due to no fuel, a clog in the fuel line, or a short in the solenoid circuit, the fuel stop solenoid will de-energize. The engine will stop.

b. *Test.*

(1) *High Temperature Switch (Fig. 4-34).*

**NOTE**

**Make sure engine temperature is below 195 °F before attempting this test.**

(a) Open the engine junction box and disconnect the two high temperature switch leads. These leads should be marked with the number 35 on a band marker.

(b) Using a continuity tester, test for continuity of the high temperature switch. If tester indicates there is continuity, the switch should be okay. If the tester shows that there is no continuity, the switch is defective and must be replaced.

- 1. Wire lead
- 2. Wire lead
- 3. Capscrew (2)
- 4. Washer (2)
- 5. Nut (2)
- 6. Star washer
- 7. Terminal
- 8. Washer
- 9. Insulated washer
- 10. Switch bracket
- 11. Insulated sleeve
- 12. Insulated washer
- 13. High temperature switch
- 14. Exhaust manifold

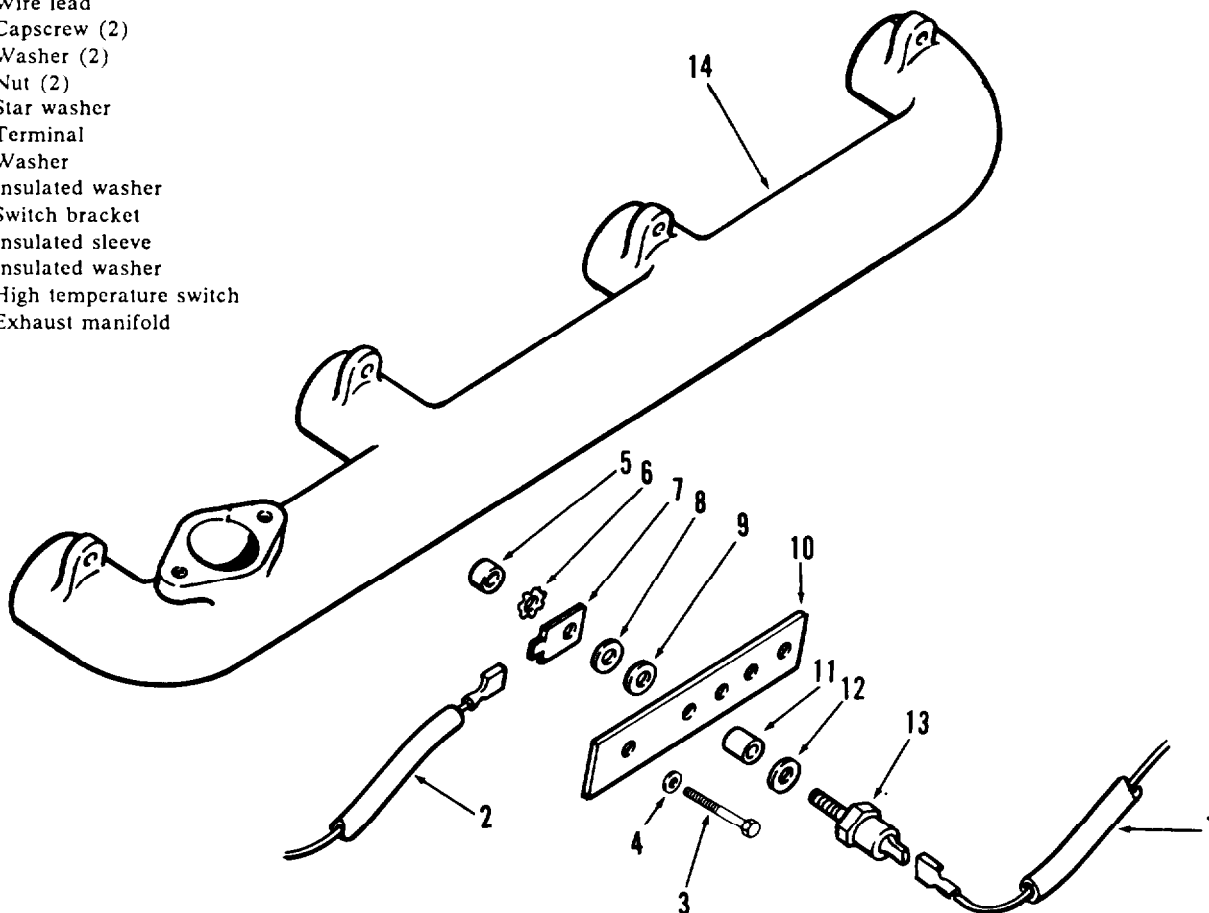

Figure 4-34. High Temperature Switch Location.

TA099789

(2) *Oil Pressure Switch (Fig. 4-35).*

(a) With engine stopped, disconnect the two leads from the oil pressure switch.

(b) Attach a continuity tester to the two terminals on the switch. Have an assistant turn over the engine several times. As oil pressure builds and exceeds 13 psi, the switch will close.

(c) Watch the continuity tester. At first there should be no continuity reading. As the switch closes, a continuity reading can be observed on the tester. If no reading is obtained, the switch is defective and must be replaced.

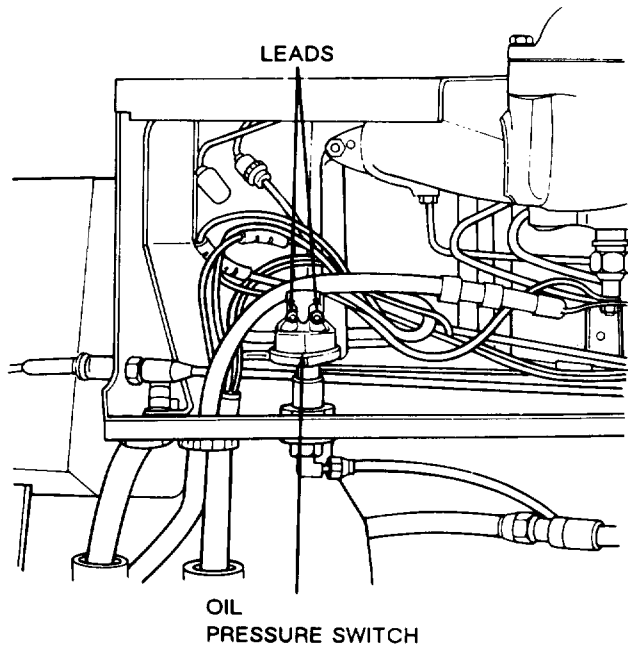

TA502347

**Figure 4-35. Location of Oil Pressure Switch.**

(3) *Fuel Stop Solenoid (Fig 4-36).*

(a) With an external 12V source connected to solenoid switch terminal, check operation of plunger and current draw.

(b) Current draw with the plunger up should be about 1 amp. If it is much more, the contacts did not close and solenoid should be replaced.

c. *Replacement of Low Oil Pressure Switch.*

(1) Remove engine shroud cover.

(2) Disconnect the two leads (fig. 4-35) from the switch. Unscrew the low oil pressure switch.

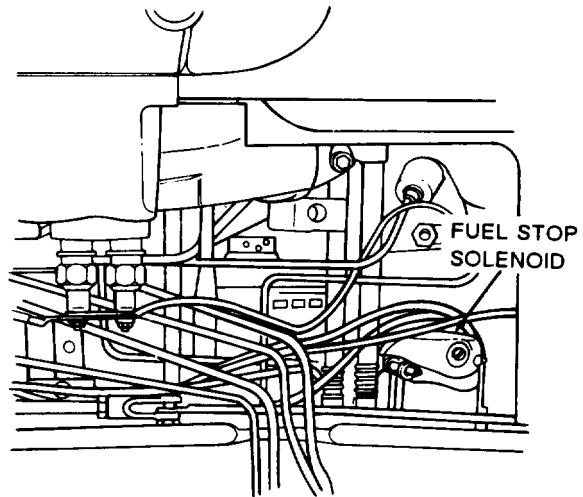

TA502348

**Figure 4-36. Location of Fuel Stop Solenoid.**

(3) Apply a thin layer of pipe compound (item 26, Appendix E) to new low oil pressure switch. Tighten securely. Reconnect the two leads to switch.

(4) Replace engine shroud cover.

**4-23. Battery and Cables**

**WARNING**

When troubleshooting an electrical malfunction or performing electrical maintenance, ALWAYS disconnect Intervehicular electrical cable from semitrailer, and negative battery cables at batteries. Failure to follow this warning may create a spark and explosion, resulting in serious injury or death to personnel.

**NOTE**

Refer to FM 9-207, Operation and Maintenance of Ordnance Material in Cold Weather (0° to -65 °F) for information on maintenance of batteries in extreme cold.

a. *Removal.*

(1) Remove two wingnuts and washers (fig. 4-37) securing battery cover to battery holddown assemblies. Remove cover.

(2) Disconnect negative, then positive battery cables from terminals.

(3) Loosen clamp bolts and remove terminals.

(4) If necessary to replace battery cables, disconnect negative battery cable at the engine frame by removing the capscrew and nut securing battery cable to the frame. To remove positive battery cable, remove the two capscrews securing buss bar cover (fig. 4-125) to the rear engine firewall, and remove cover. Disconnect positive cable from buss bar and remove cable.

(5) Loosen two nuts on each of four T-bolts (fig. 4-37), and remove the two battery holddown assemblies. Carefully remove batteries.

b. *Cleaning.* Tighten vent filler caps so no cleaning solution will enter cells. Clean battery with baking soda and water solution and a stiff brush. If terminal clamps and battery posts are corroded, clean with a post and terminal brush.

c. *Water Addition.* The water in the electrolyte solution will evaporate at high temperatures or from an excessive charging rate. Check electrolyte level and add distilled or clean water to just below the ring at bottom of cell opening. DO NOT use acid!

**WARNING**

**Batteries contain sulfuric acid that causes severe burns. If acid contacts eyes, skin, or clothing, flush well with water. For contact with eyes, get immediate medical attention.**

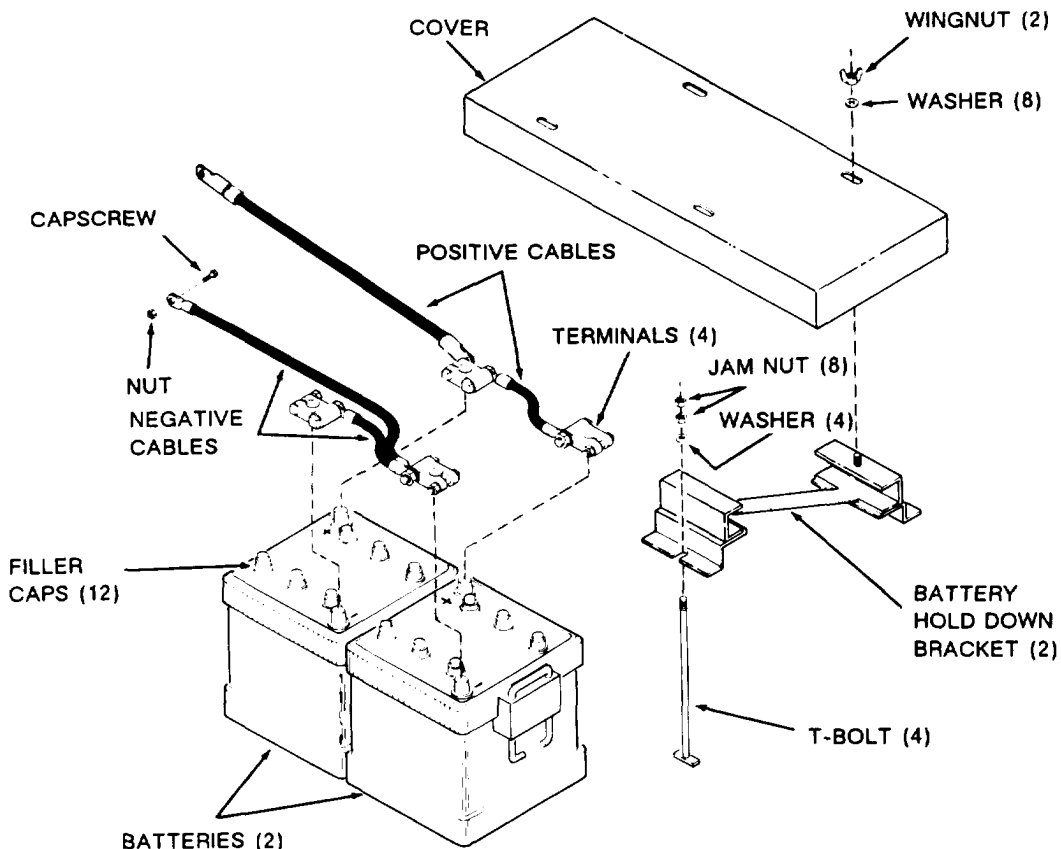

Figure 4-37. Battery Installation.

TA099792

**NOTE**

**If water must be added to check specific gravity, fast charge battery for 30 minutes or false readings will be obtained.**

d. *Checking Specific Gravity.* A hydrometer or an antifreeze/battery tester is used to check the specific gravity (weight) of the battery electrolyte. The specific gravity of the electrolyte indicates the approximate state of charge of the battery. Hydrometers are calibrated to give the true reading when the electrolyte temperature is 80°F. Therefore, to obtain a correct specific gravity reading, the temperature of the electrolyte must be known. Some hydrometers contain a thermometer while others do not. A separate thermometer is required to check electrolyte temperature if the hydrometer is not so equipped. Refer to figure 4-38 for hydrometer temperature corrections. An antifreeze/battery tester is already temperature corrected.

(1) *Test.*

(a) Remove electrolyte from one cell at a time with the hydrometer. Observe and record the hydrometer reading. Be sure to hold the hydrometer vertical, check that the float is free, and take reading at eye level.

(b) Note the electrolyte temperature. Refer to figure 4-38 and add or subtract four (.004) specific gravity points for each 10° above or below 80°F. The corrected reading will be a true indication of cell condition.

(c) Repeat steps (a) and (b) for remaining cells.

(2) *Interpretation of Hydrometer Readings.*

(a) The approximate state of charge can be determined by comparing readings to specific gravity (table 4-11).

(b) If all cells read between 1.200 and 1.260, and the variation between the high and low cell is less than 30 gravity points, the battery is good. It may be necessary to charge the battery before use.

(c) If all cells read between 1.200 and 1.260, and the variation between the high and low cell is 30 gravity points or more, fully charge battery and recheck specific gravity. If the variation is still 30 gravity points or more after charging, the battery is defective and must be replaced.

(3) Testing with an antifreeze/battery tester is done by following directions printed on the tester.

Table 4-11. *Specific Gravity Table.*

State of Charge	Specific gravity at 80°F	Electrolyte Freezes approx.
100%	1.260	-75° F
75%	1.230	-38°F
50%	1.200	-17°F
25%	1.170	1°F
Discharged	1.110	19°F

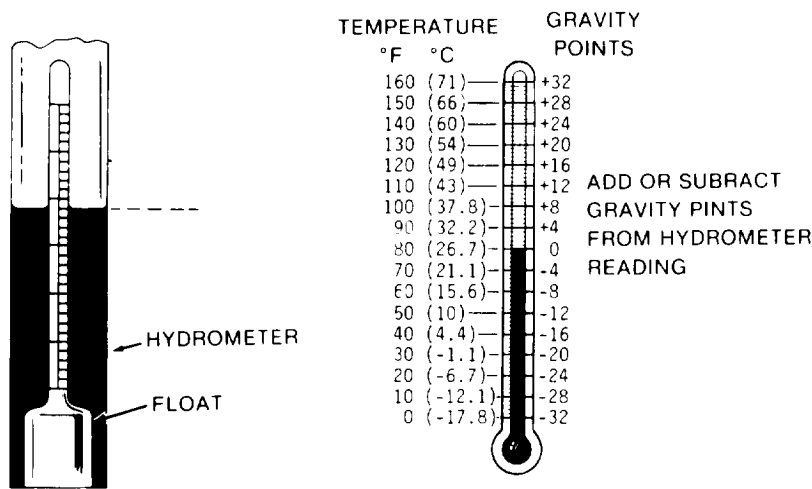

Figure 4-38. *Hydrometer Temperature Correction.*

TA099793

e. *Charging Battery.*

**WARNING**

- **Batteries produce explosive gases. Keep sparks, flame, and smoking material away. Ventilate when charging or using in an enclosed space.**
- **The batteries contain sulfuric acid that causes severe burns. If acid contacts eyes, skin, or clothing, flush well with water. For contact with eyes, get immediate medical attention.**

**CAUTION**

**Always disconnect negative cables first.**

(1) Remove batteries from vehicle when necessary to charge in accordance with TM 9-6140-200-14.

(2) If dry batteries are used and vehicle is not placed in immediate service, slow charge with charger at not more than 10 amperes. Charge until cells gas freely or until electrolyte exceeds 120 °F. Reduce charge rate by ½

on each occurrence to remain within the restrictions, topping off at a 1 ampere rate. To fully charge, top off until each cell has less than a 25 point variation and an average specific gravity of 1.280 to 1.290, corrected (fig. 4-38), measured in three readings spaced at ½ hour intervals.

f. *Installation of Battery.*

(1) Position batteries on engine frame with positive posts closest to the engine. Place battery holddown assemblies securely on battery.

**CAUTION**

**Batteries to be connected in parallel only.**

(2) Position and secure the clamp of the positive battery cable (48-inch long) on the positive battery post. If cable has been completely removed, secure the other end of cable to the buss bar (fig. 4-27) with a bolt, washer, and nut. Replace buss bar cover.

(3) Position and secure the clamp of the negative battery cable on the negative battery post. If cable has been completely removed, secure the other end of cable to engine frame (ground) with capscrew and nut.

(4) Position battery cover on battery holddowns and secure with wingnuts and washers (fig. 4-37).

## Section IX. MAINTENANCE OF ENGINE CONTROL PANEL

### 4-24. Switches, Gages, and Indicator Light

**WARNING**

- **When troubleshooting an electrical malfunction or performing electrical maintenance, ALWAYS disconnect intervehicular electrical cable from semitrailer, and negative battery cables at batteries. Failure to follow this warning may create a spark and explosion, resulting in serious injury or death to personnel.**
- **Check for fuel leaks at gage tube connections before performing electrical testing at control panel. Stop any leaks and wipe up spills.**

a. *Testing Instruments, Switches, and Indicator Light.* When an instrument shows an abnormal indication, the trouble should be checked immediately and either corrected or referred to proper authority to make the necessary correction. If operation of the engine, pump, or

filter/separator indicates no trouble and the instrument is suspected of being defective, replace it with a new instrument, known to be good, if available. Other tests can be made as follows:

(1) Make a continuity test of wiring and switches using a multimeter (para 4-9).

(2) Visually check instruments for broken glass, damaged terminals, corrosion, and damage to cases and capillary tubes. Check wiring for broken or damaged insulation and for broken wires. Check couplings and lines to pump, filter/separator, and fuel and oil gages for looseness and damage.

(3) Check conduit at back of panel for kinks or breaks. Check conduit fittings for tightness. Make sure decals are in place, clean, and readable. Check that all switches are tight and no fasteners are missing or loose.

b. *Replacement of Switches, Instruments, and Indicator Light.* Refer to figure 2-9 for location of switches and instruments on the control panel. Refer to figures 4-39, 4-40, and 4-41, and engine control panel electrical schematic diagram (figs. 4-42 and 4-43) as a guide for

replacement. All switches and instruments must be replaced from the rear of the panel. Disconnect the negative ground lead from the battery. Remove six round head screws (fig. 4-39) holding control panel to frame. Swing control panel door down and hold open at 90° with 20-inches of safety wire threaded through one hole in door and corresponding hole in panel. Mark all leads before disconnecting. After replacing any component, close panel door and replace six screws.

(1) *Engine Switches (Preheater Starter and Engine).*

(a) Disconnect the electrical leads (fig. 4-41) from switch.

(b) Remove the screw and washer (fig. 4-39) that secures the switch lever to the switch.

(c) Remove the nut and lockwasher from outside the panel, and remove switch.

**NOTE**

**Align locating tab on switch with locating hole in cover.**

(d) Install new switch in reverse order of steps (a) through (c).

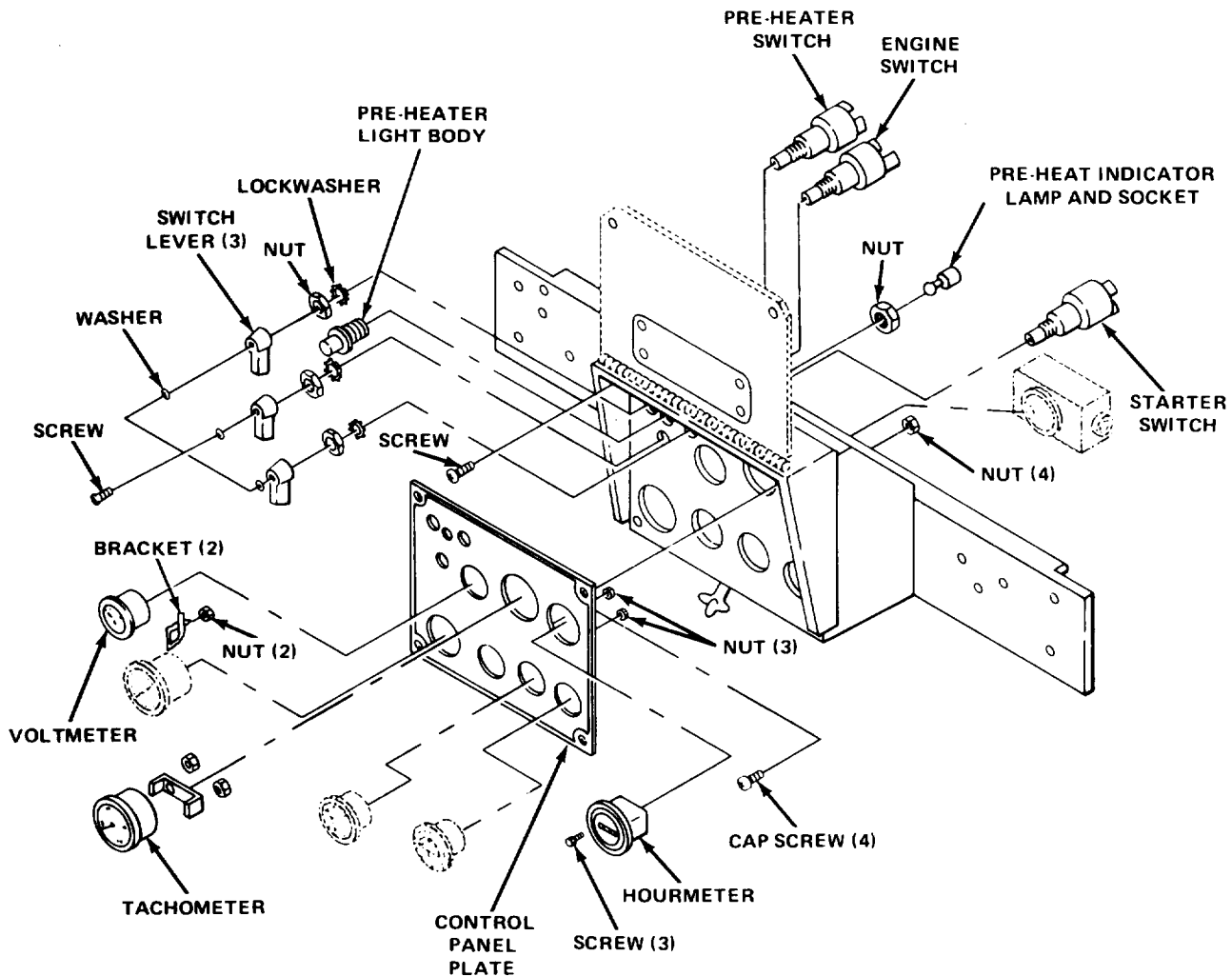

Figure 4-39, Switches and Electrical Gages in Control Panel.

TA223026



(2) Voltmeter and/or Pump Pressure Gage.

**NOTE**

**Put suitable container under tube connections to catch fuel.**

(a) Remove electrical lead (fig. 4-41) from rear of voltmeter, and/or tube connector (fig. 4-40) from rear of pump pressure gage.

(b) Remove two nuts and brackets that retain meter or gage to control panel.

(c) Remove meter or gage from panel.

(d) Remove snubber from pump pressure gage.

(e) Install new meter or gage in reverse order of steps (a) through (c).

(f) Cleanup all fuel spills.

(3) Tachometer and/or Hourmeter.

(a) Tag and disconnect electrical leads (fig. 4-41) from rear of tachometer and/or disconnect connector in hourmeter line.

(b) Remove three screws and nuts from hourmeter and pull meter out from front of control panel.

(c) Remove two nuts and bracket that retains tachometer to control panel and pull meter out from front of panel.

(d) Install new meter in reverse order of steps (a) and (b), being careful to reconnect leads exactly as they were connected to the meter that was removed.

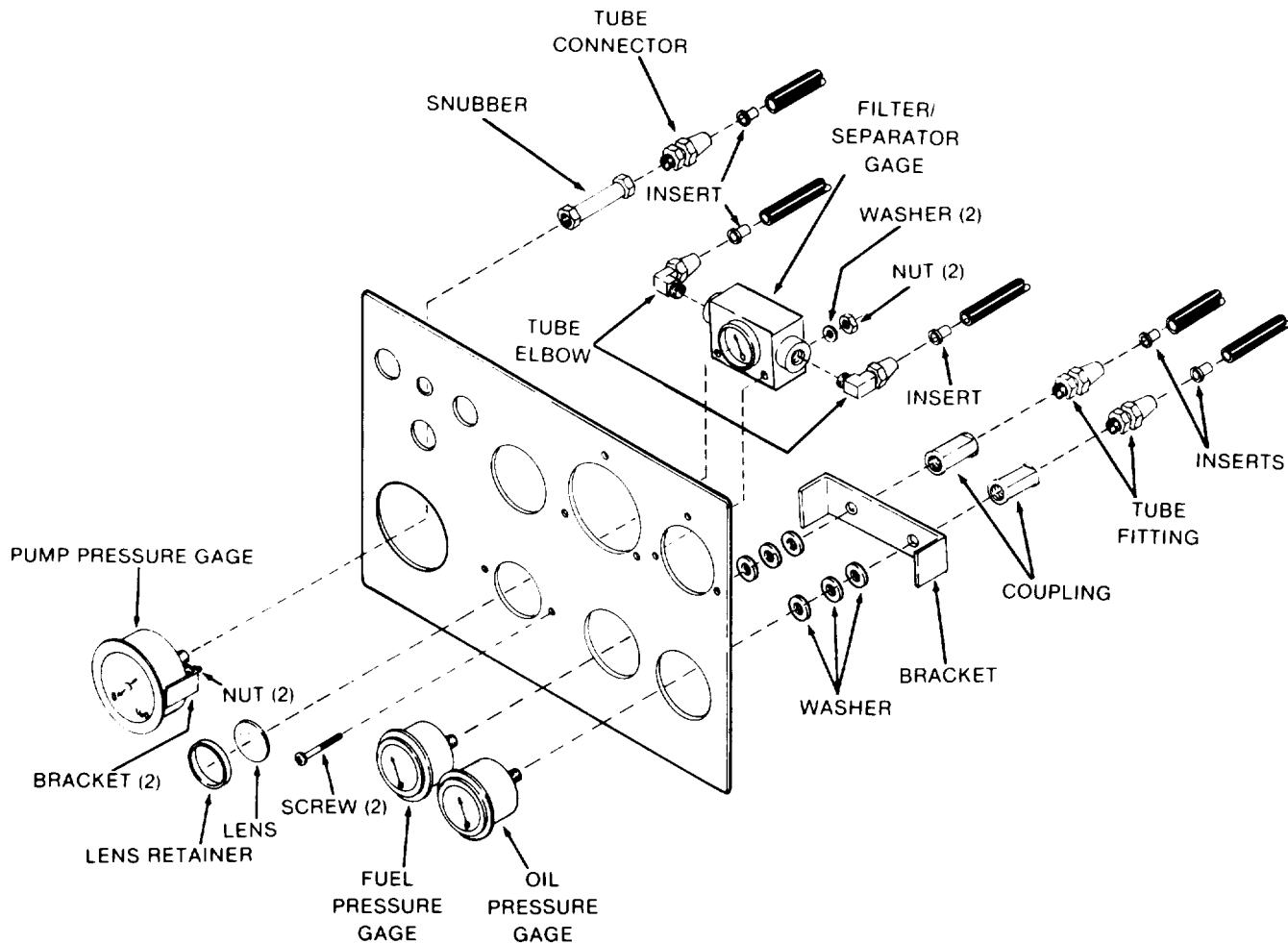

**Figure 4-40. Pressure Gages in Control Panel.**

TA099795

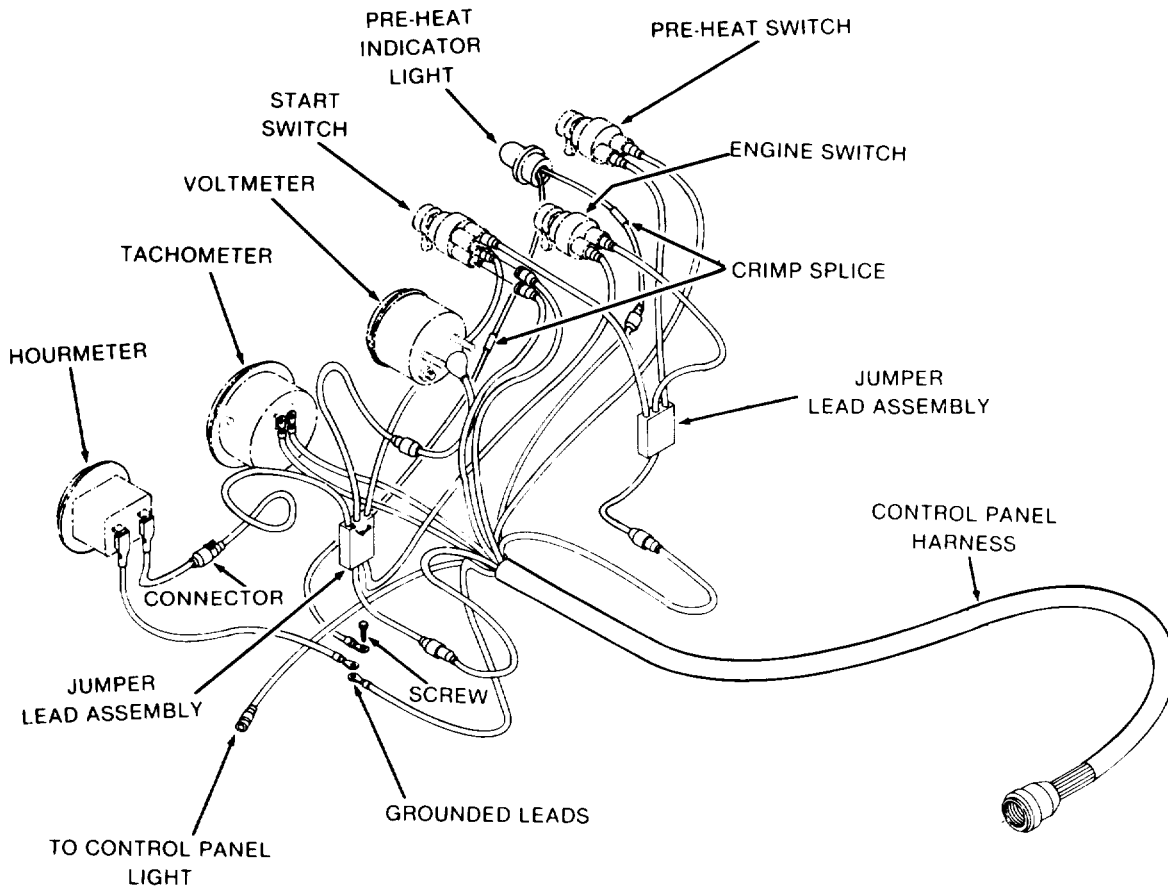

TA099796

Figure 4-41. Engine Control Panel Wiring

(4) Filter/Separator Gage.

(f) Clean up all fuel spills.

(5) Fuel Pressure and/or Oil Pressure Gages.

**NOTE**

**Put suitable container under tube connections to catch fuel.**

**NOTE**

**Put suitable container under tube connections to catch fuel.**

- (a) Disconnect lines from 90° tube elbows (fig. 4-40)
- (b) Remove lens and cover from front of gage.
- (c) Remove two screws, washers, and nuts that secure gage to control panel.
- (d) Remove gage. Remove both elbows from gage.
- (e) Install gage in reverse order of steps (a) through (d).

- (a) Disconnect line from tube fitting at rear of gage.
- (b) Remove coupling securing gage to bracket on control panel.
- (c) Remove gage and four washers through front of control panel.
- (d) Install new gage in reverse order of (a) through (c). Be sure to shim gage with existing washers.
- (e) Clean up all fuel spills.

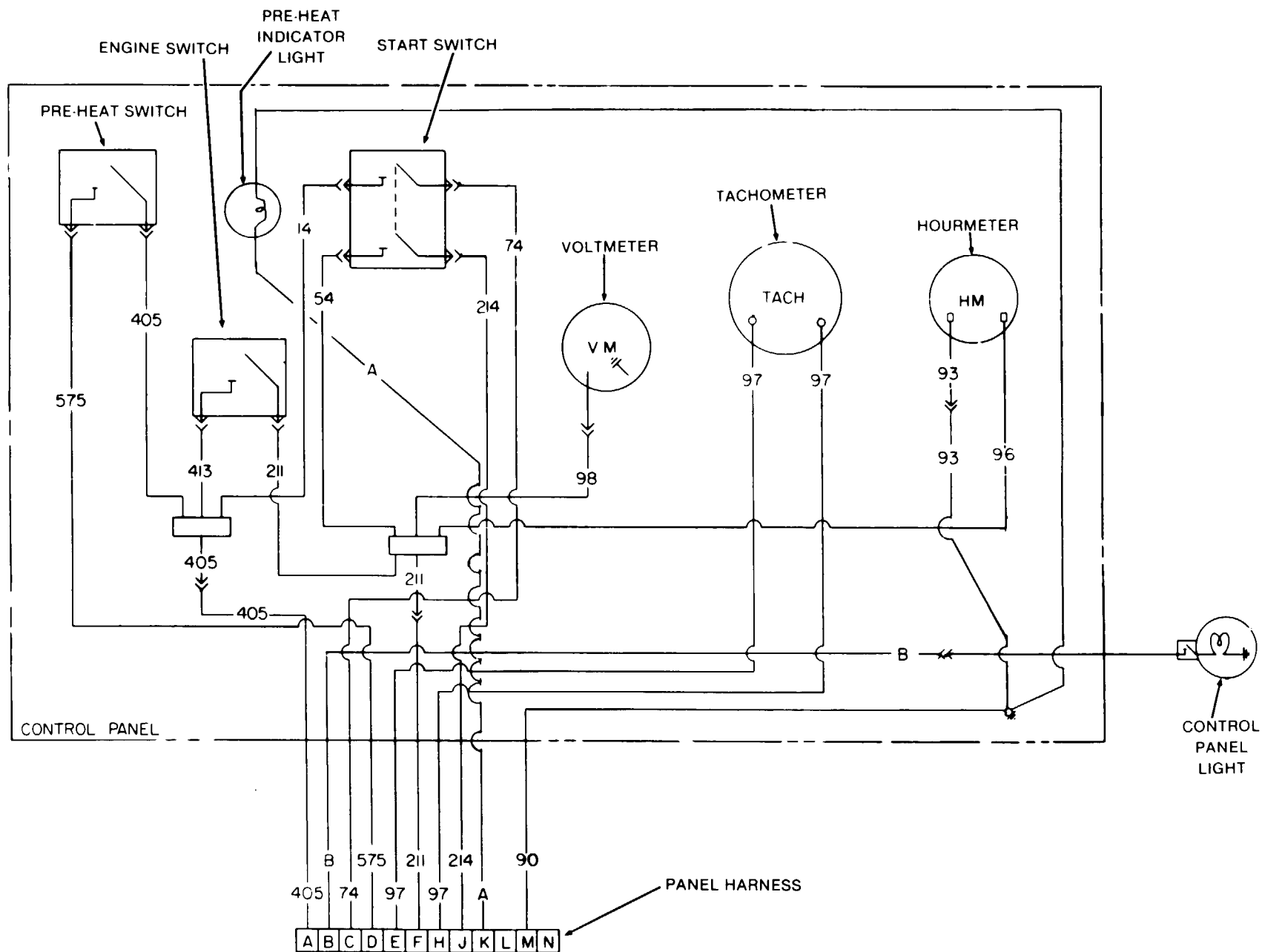

Figure 4-42. Instrument Panel Wiring Schematic (M967, M969, and M970) (Use With Tachometer 1227092 Only).

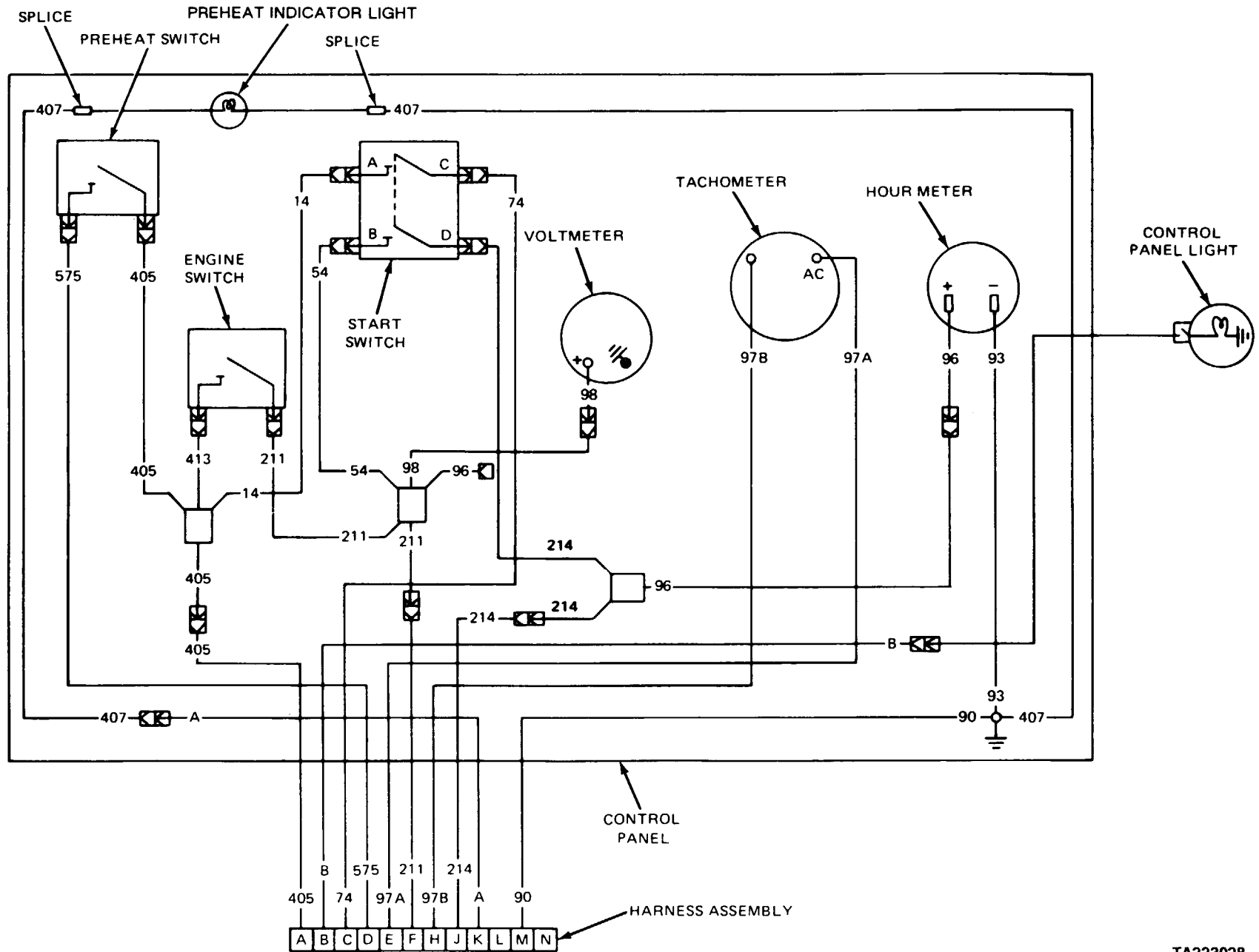

Figure 4-43. Instrument Panel Wiring Schematic (M967, M967A1, M969, M969A1, M970, M970A1) (Use With Tachometer 12275405 Only).

TA223028

c. *Replacement of Preheat indicator Light.* Refer to figures 4-39 and 4-41, and engine control panel schematic figures 4-42 and 4-43 as guides for replacement of indicator light.

(1) *Removal.*

(a) Disconnect negative battery lead from battery (para 4-23).

(b) Remove six screws (fig. 4-39) securing control panel door and pull door open. Hold door at a 90° angle with control panel with a 20-inch length of safety wire threaded through one hole in door and corresponding hole in control panel.

(c) Separate indicator light socket (fig. 4-39) from light body by pulling on socket.

(d) Remove nut and washer securing light body to control panel door. Remove light body.

(e) Remove crimp splices (fig. 4-41) on the indicator light ground leads. Disconnect the other lead from control panel harness.

(f) Remove indicator light socket.

(2) *Installation.*

(a) Insert light body (fig. 4-39) through hole in door and secure with washer and nut.

(b) Insert socket into light body.

(c) Connect the light ground lead (fig. 4-41) to the existing wire using a crimp splice. Install remaining wire by crimping splice to control panel harness.

(d) Remove safety wire from control panel door and close door. Be sure that tubing to gages is not folded or crimped. Secure door with six screws.

(e) Install battery negative ground lead (para 4-23).

d. *Preheat Indicator Light Lamp Replacement.*

(1) Remove six screws (fig. 4-39) securing control panel door and pull door open.

(2) Separate indicator light socket from light body.

(3) Remove lamp from the indicator socket and install a new lamp.

(4) Replace indicator light socket into light body.

(5) Close panel door. Be sure that tubing to gages is not folded or crimped. Secure door with six screws.

e. *Replacement of Control Panel Plate.* Remove all switches, gages and light following instructions in *b* and *c* above. Remove four capscrews (fig. 4-39) which fasten plate to control panel. Remove control panel plate. Install new plate and reinstall switches, gages, and light.

f. *Repair of Wiring.* Repair any cracked, cut, or broken insulation with electrical tape (item 29, Appendix E). Replace wiring when damage cannot be repaired. Tighten loose connections.

**4-25. Control Panel Wiring Harness and Conduit**

**WARNING**

**When troubleshooting an electrical malfunction or performing electrical maintenance, ALWAYS disconnect intervehicular electrical cable from semitrailer, and negative battery cables at batteries. Failure to follow this warning may create a spark and explosion, resulting in serious injury or death to personnel.**

a. *Repair of Wiring.* Repair any cracked, cut, or broken insulation with electrical tape (item 29, Appendix E). Replace wiring harness when damage cannot be repaired.

b. *Replacement of Control Panel Wiring Harness.*

(1) *Removal.*

(a) Open control panel by removing six round head screws (fig. 4-39) and swinging panel down.

(b) Disconnect all electrical leads and jumper assemblies from control panel wiring harness (fig. 4-41).

(c) With a wire cutter, remove all terminals from the ends of the harness wires.

(d) Disconnect the wiring harness from the engine junction box (fig. 4-44).

(e) Secure a strong cord, about ten feet longer than the harness, to the end of the wiring harness.

(f) Pull harness out of conduit and allow cord to be pulled into the conduit. When harness is out, cord should be visible at both ends of conduit.

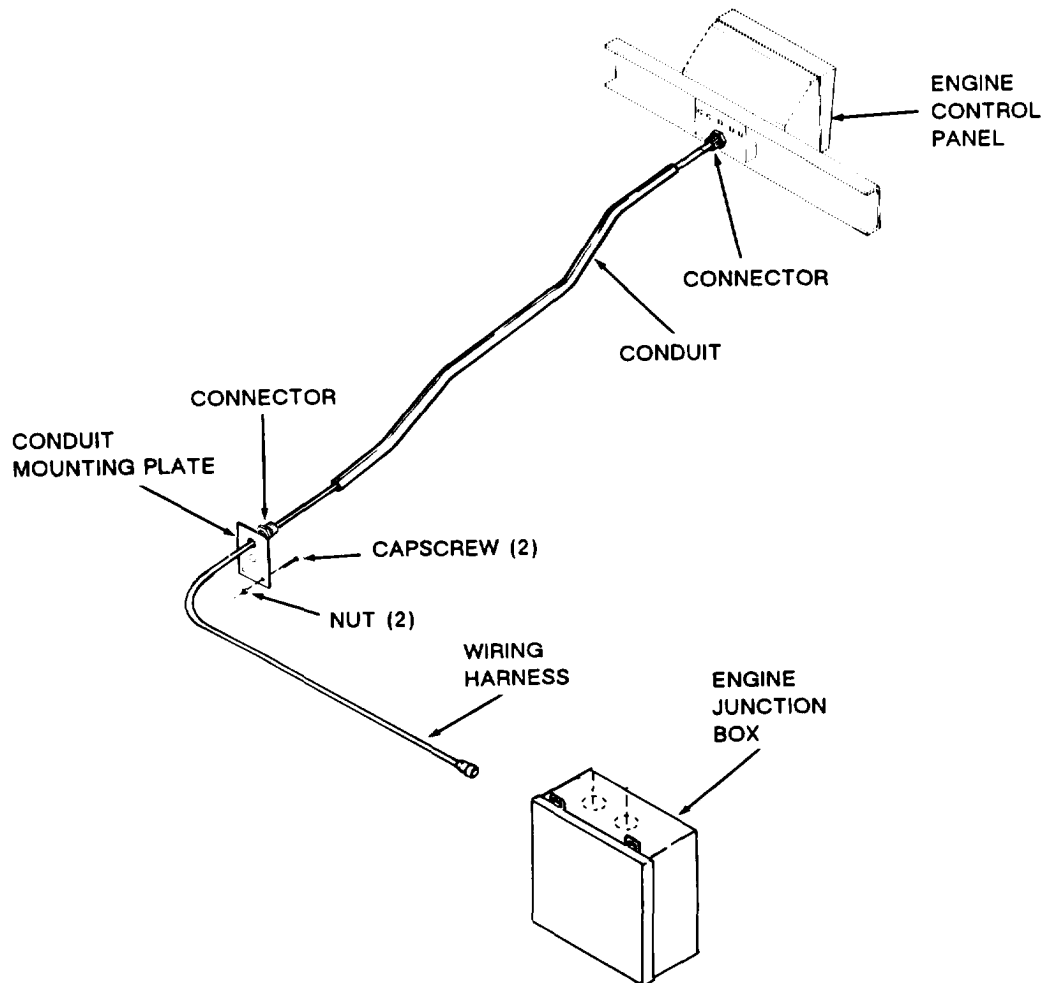

**Figure 4-44. Control Panel Conduit Installation.**

*(2) Installation.*

(a) Tape together all loose wires on control panel end of new harness.

(b) Coat entire harness with silicon or a mild soap solution.

(c) Attach new harness to cord that is in the conduit.

(d) Pull wiring harness through conduit using the cord until end of harness is in control panel box and leads are long enough to reach panel wiring leads and jumper assemblies.

(e) Remove cord from end of harness and install new terminals to wires.

**CAUTION**

**Be sure leads and jumpers are properly connected.**

(f) Connect harness wires to control panel leads and jumper assemblies.

(g) Close control panel and install six round head screws. Be sure tubing to gages is not folded or crimped.

(h) Connect wiring harness to engine junction box (fig. 4-44).

*c. Replacement of Control Panel to Engine Junction Box Conduit.*

*(1) Removal.*

(a) Remove control panel wiring harness (step b).

(b) Loosen both conduit connectors (fig. 4-44).

(c) Remove two capscrews and nuts that secure conduit mounting plate to engine mounting frame.

(d) Remove mounting plate and conduit.

(2) *Installation.*

(a) Install conduit connectors (fig. 4-44) if they were removed.

(b) Place end of conduit in conduit connector attached to control panel.

(c) Insert other end of conduit into connector in mounting plate and attach plate to frame with two capscrews and nuts.

(d) Tighten conduit connectors to secure conduit in place.

(e) Install wiring harness (step b).

**4-26. Control Panel Light (Fig. 4-45)**

a. *Replacement of Lamp.*

**WARNING**

**When troubleshooting an electrical malfunction or performing electrical maintenance, ALWAYS disconnect intervehicular electrical cable from semitrailer, and negative battery**

**cables at batteries. Failure to follow this warning may create a spark and explosion, resulting in serious injury or death to personnel.**

**CAUTION**

**Be careful not to crack lens by prying too hard with screwdriver.**

- (1) Using a screwdriver, loosen lens from body.
- (2) Press down on lamp, and turn to remove lamp.

- (3) Replace lamp.
- (4) Press lens into light body.

b. *Removal.*

- (1) Open control panel (para 4-24).
- (2) Disconnect terminal (fig. 4-45) from control panel wiring harness.

- (3) Remove terminal from electrical lead.

- (4) Remove conduit connector (fig. 4-45) from each end of tubing between control panel and light assembly.

- (5) Remove two screws and nuts which fasten light assembly to hose trough.

- (6) Remove light and pull wire from conduit.

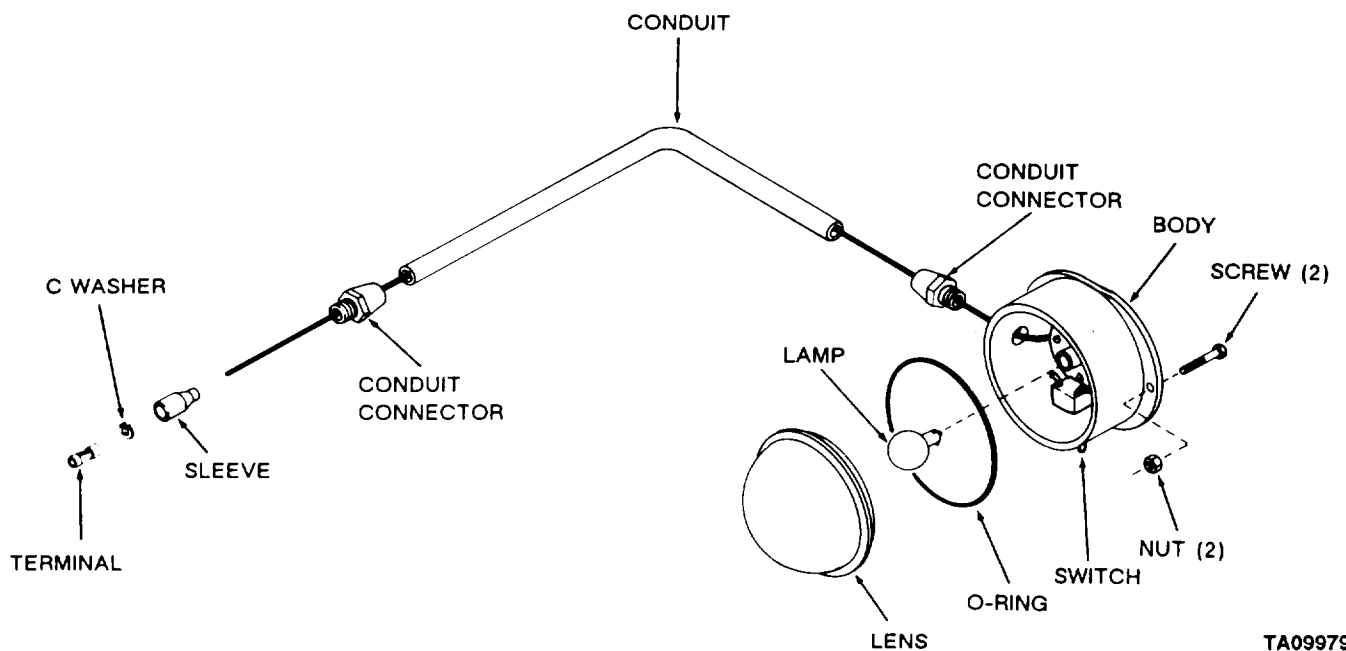

Figure 4-45. Control Panel Light Installation.

TA099799

c. *Cleaning and Inspection.*

- (1) Wipe dirt and other matter from light.
- (2) Inspect light for broken or cracked lens and corroded socket.
- (3) Inspect body and switch for damage.
- (4) Replace damaged parts or replace light.

d. *Installation.*

- (1) Thread wire through conduit into control panel box.

(2) Attach light to hose trough with two screws and nuts.

(3) Attach conduit connector (fig. 4-45) to light assembly and control panel.

(4) Replace terminal on end of wire and connect to control panel wiring harness.

(5) Connect battery ground negative cable (para 4-23) and check operation of light.

## Section X. MAINTENANCE OF HOSE REEL ELECTRICAL SYSTEM

### 4-27. Hose Reel Wiring

#### **WARNING**

**When troubleshooting an electrical malfunction or performing electrical maintenance, ALWAYS disconnect intervehicular electrical cable from semitrailer, and negative battery cables at batteries, Failure to follow this warning may create a spark and explosion, resulting in serious injury or death to personnel.**

a. *General.* The hose reel electrical system consists of items listed below. Use figures 4-46 and 4-47 as references.

- (1) Buss fuse
- (2) Solenoid junction box
- (3) Solenoids (2)
- (4) Junction box on hose reel motor (2)
- (5) Hose reel rewind switches

(6) Cable assemblies

b. *Repair.* The repair of most of the wiring can be performed without removing the cables from the conduit.

(1) Clean ends of cables with a damp cloth.

(2) Check ends of cables for frayed insulation or broken wires. Tape or replace frayed wires.

(3) Inspect wires for bent, broken, or missing terminals. Replace missing or damaged terminals.

c. *Replacement of Wiring.* Use figures 4-46 and 4-47 as guides in replacing cables. Remove the cover on any electrical component to gain access to lead terminals. Pull old lead from conduit and install new lead with a lacing wire, if necessary.

d. *Replacement of Conduit.* Use figures 4-48 and 4-49 as guides in replacing conduit. Remove cables from conduit to be replaced. Loosen conduit connectors on each end of conduit and remove conduit. The conduit between engine compartment and junction box can be replaced by adapting instructions in paragraph 4-25.



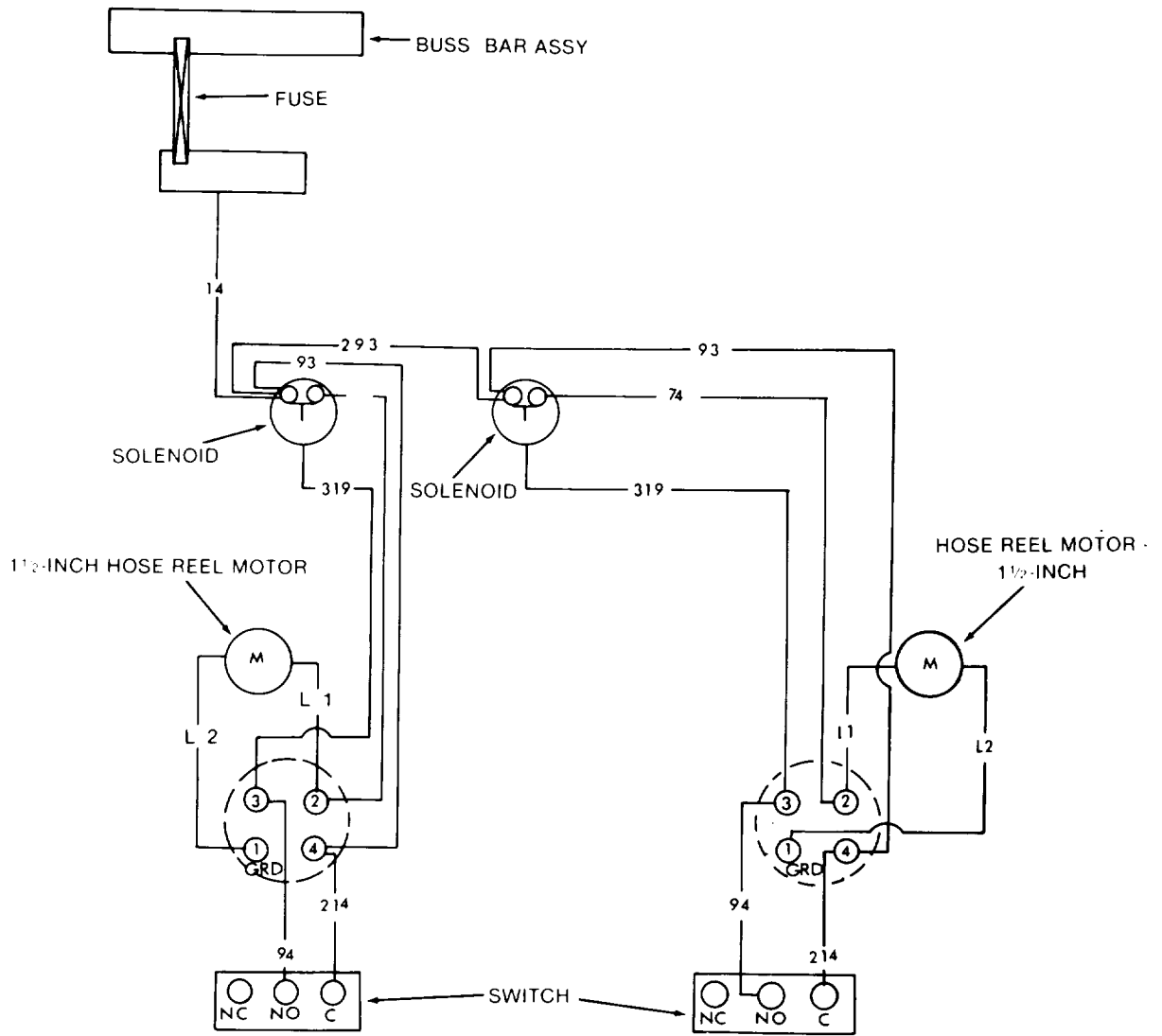

Figure 4-46. Hose Reel Wiring Diagram (M969 and M969A1).

TA099800

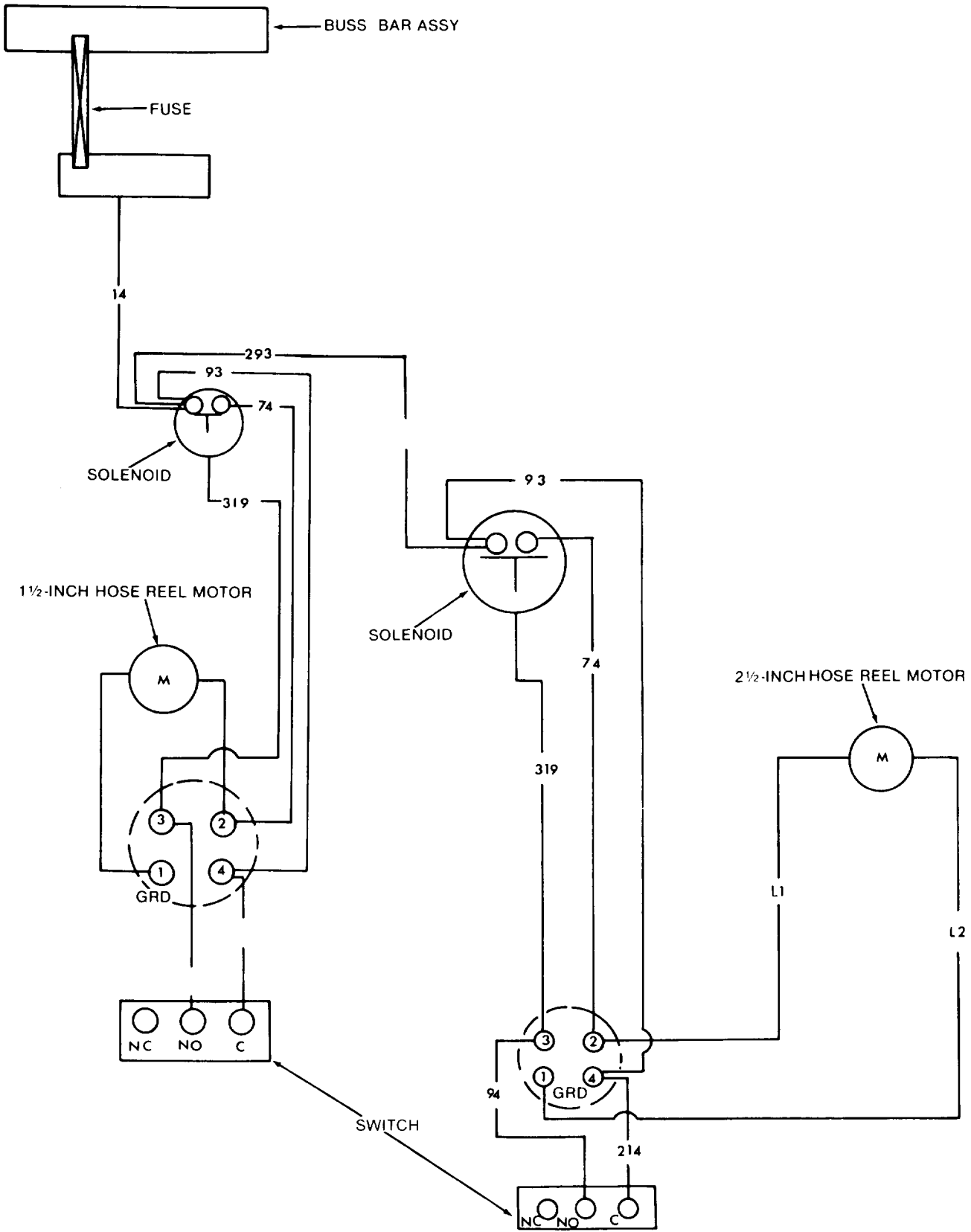

Figure 4-47. Hose Reel Wiring Diagram (M970 and M970A1).

TA099801

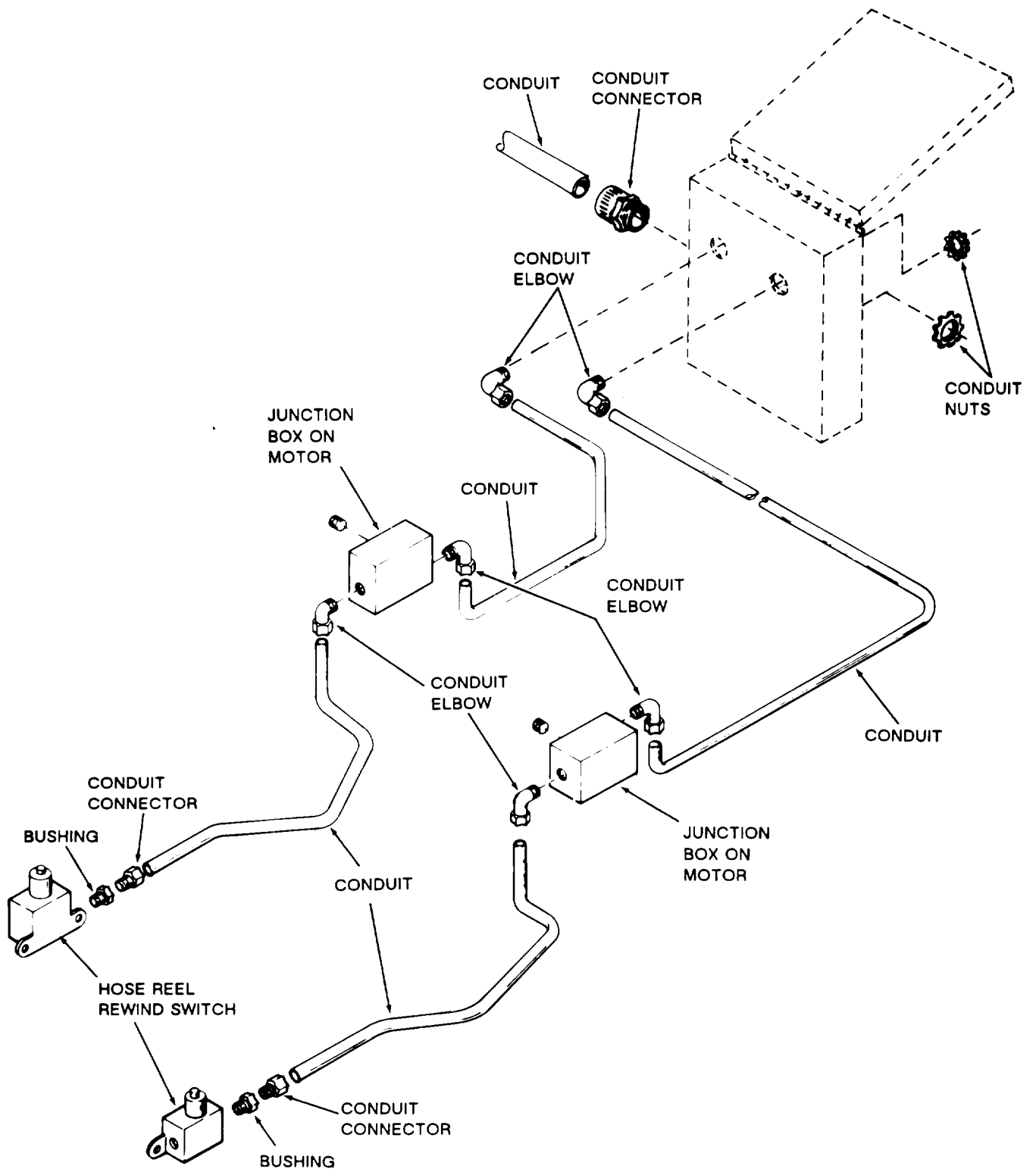

Figure 4-48. Hose Reel Cabinet Conduit (M969 and M969A1).

TA099802

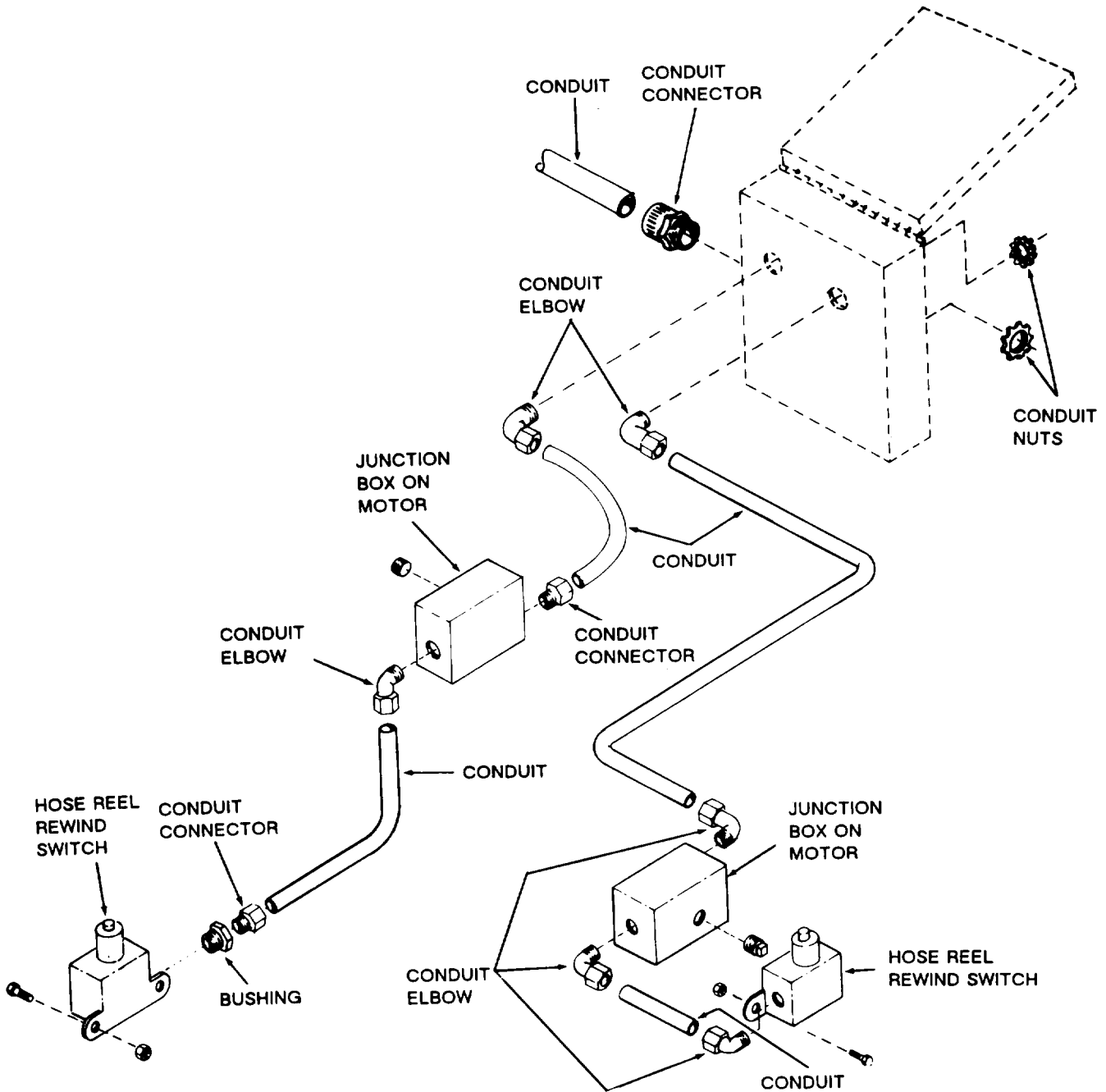

Figure 4-49. Hose Reel Cabinet Conduit (M970 and M970A1).

Section XI. MAINTENANCE OF BOGIE ASSEMBLY

**4-28. General, M967, M969, and M970 except M970 SN TC-0843, TC-0844, and TC-103 thru TC-178.**

*a. Preliminary.* Position semitrailer on hard level surface with front resting on landing gear. Jack and block rear of frame. Remove wheels (para 4-49).

*b. Inspection.* Clean axle and suspension system with water and fiber brush to allow for careful inspection.

(1) Inspect general condition of tandem tube, torque rods, and spring leaves. Look for cracks or damage.

(2) Cheek torque rods (fig. 4-50) for looseness (table 4-12). Look for deterioration of ball assemblies.

(3) Check tightness of U-bolts (fig. 4-50) and clips on leaf springs (table 4-12),

**Table 4-12. Tabulated Torque Values—Bogie Assembly M967, M969, and M970 except M970 SN TC-0843, TC-0844, and TC-103 thru TC-178).**

Location/Description	Torque
Spring U-Bolts (Nuts)	200-320 lb.-ft.
Hub Cap Retainer Screws	16-20 lb.-ft.
Lower Torque Rod Assembly Nuts	350-400 lb.-ft.
Upper Torque Rod Assembly Nuts	350-400 lb.-ft.
Spring Seat Cover Screws	16-20 lb.-ft.
Wheel Stud Nuts	450-500 lb.-ft.

(4) Look for cracked welds, damage to backing plates, worn brake hoses, or cracked brake drum.

(5) Check tightness of bolts which fasten bogie assembly to trailer frame.

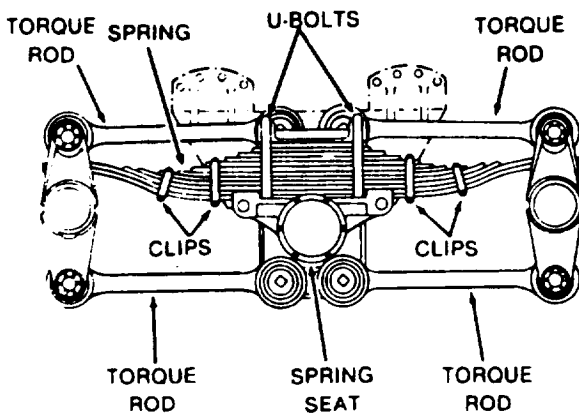

TA099804

**Figure 4-50. Bogie Assembly (M967, M969, and M970 except M970 SN TC-0843, TC-0844, and TC-103 thru TC-178).**

(6) Look for leakage around seals in spring seats.

*c. Repair.* Tighten loose bolts. If damage or wear is evident, notify direct support maintenance.

**4-29. General, M967A1, M969A1, and M970A1 including M970 SN TC-0843, TC-0844, and TC-103 thru TC-178.**

*a. Preliminary.* Position semitrailer on hard level surface with front resting on landing gear. Jack and block rear of frame. Remove wheels (para 4-49).

*b. Inspection.* Clean axle and suspension system with water and fiber brush to allow for careful inspection.

(1) Inspect general condition of trunnion tube, axles and spring leaves. Look for cracks or damage.

(2) Check tightness of U-bolts (fig. 4-51), and clips on leaf springs (table 4-13).

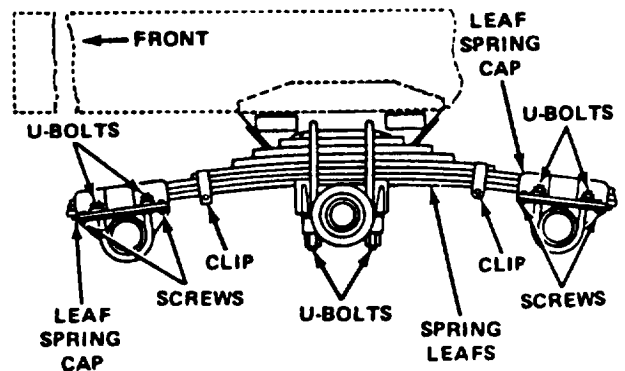

TA221203

**Figure 4-51. Bogie Assembly (M967A1, M969A1, and M970A1 including M970 SN TC-0843, TC-0844, and TC-103 thru TC-178).**

(3) Check tightness of U-bolts and screws (fig. 4-51) on leaf spring cap and seat (table 4-13).

(4) Look for cracked brake drum.

**Table 4-13. Tabulated Torque Values—Bogie Assembly, M967A1, M969A1, and M970A1 including M970 SN TC-0843, TC-0844, and TC-103 thru TC-178).**

Location/Description	Torque
Spring U-Bolts (Nuts)	200-320 lb.-ft.
Spring Cap and Seat U-Bolts (Nuts)	300 lb.-ft.
Spring Cap and Seat Screws	240 lb.-ft.
Hub Cap Retainer Bolts	16-20 lb.-ft.
Wheel Stud Nuts	450-500 lb.-ft.

(5) Look for damaged brake camshaft.

(6) Look for worn brake hoses or damaged broke chamber.

(7) Check tightness of bobs which fasten bogie assembly to trailer frame.

c. *Repair.* Tighten loose bolts. If damage or wear is evident, notify direct support maintenance.

**4-30. Spring Seat Bearings, M967, M969, M970 except M970 SN TC-0843, TC-0844, and TC-103 thru TC-178.**

a. *Lubrication Internal.* See figures 3-1 through 3-6, Lubrication Chart.

b. *Procedure.* Remove plug A on bottom of spring seat (fig. 3-7) and install a 1/4-inch NPT grease fitting. Apply enough grease to ensure lubrication of the bearings. Remove grease fitting and install plug.

c. *Replacement of Bearings.* If excessive wear is evident in the spring seat bearings, notify direct support maintenance.

**Section XII. MAINTENANCE OF BRAKE SYSTEM**

**4-31. General, M967, M969, and M970 except M970 SN TC-0843, TC-0844, and TC-103 thru TC-178.**

a. *Description.* The semitrailer brakes are air-operated, wedge-type brakes. Two air chambers and two spring chambers (fail-safe unit) are assembled on each axle. The brake chamber forces a wedge between two rollers in the plunger housing (fig. 4-52). Wedge action causes the plungers in the actuator assembly to push the brake shoes against the brake drum.

(1) The brakes are double-actuated. One of the actuating assemblies is shown in figure 4-52. The brake

chamber is threaded into the wedge bore of the plunger housing.

(2) The socket in the end of the diaphragm push rod connects the brake chamber to the wedge rod.

(3) The wedge retracting spring acts as the return spring for both the wedge and the diaphragm.

(4) Rollers on the wedge head engage slots in the inner ends of the plungers. The outer end of the plungers are in contact with the brake shoes.

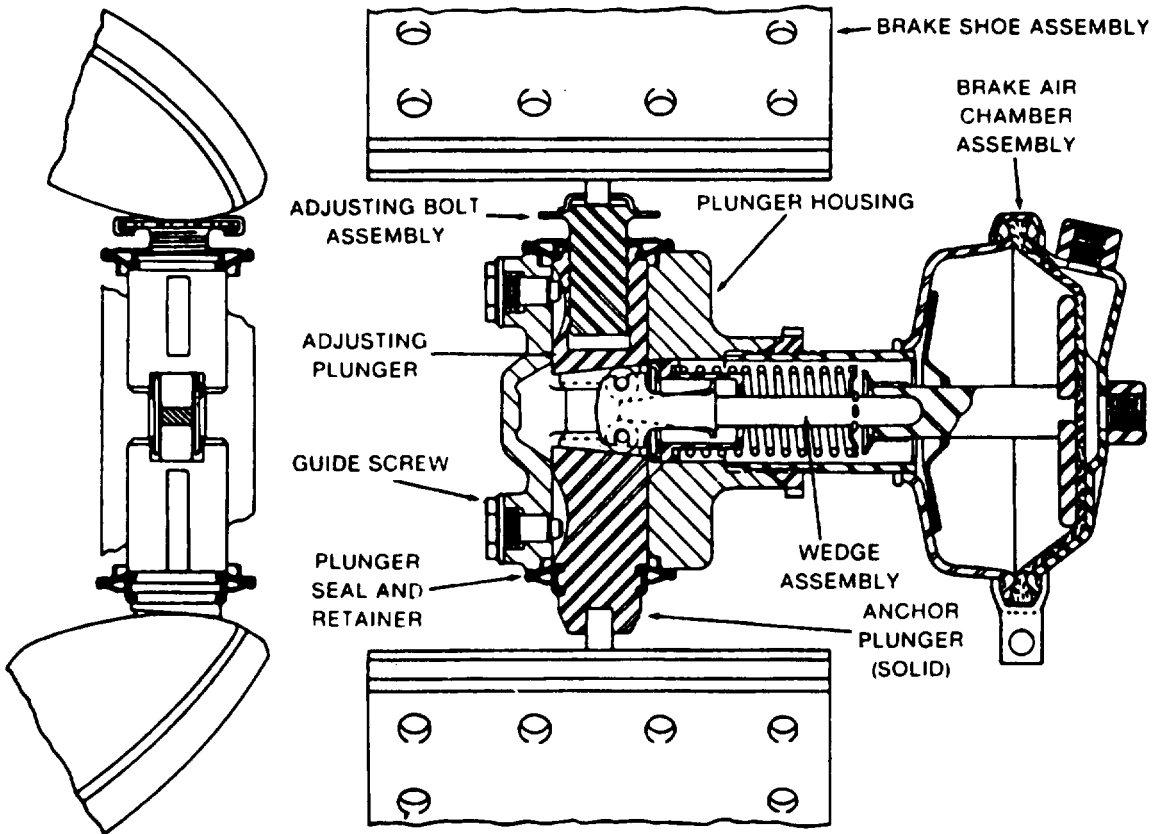

Figure 4-52. Brake Actuator Assembly (M967, M969, and M970 except M970 SN TC-0843, TC-0844, and TC-103 thru TC-178).

(5) Each actuator has one solid plunger and one adjustable plunger. The adjustable plunger is used to adjust brake shoe-to-drum clearance.

*b. Actuation.* When the brake is actuated, the push rod of the brake chamber forces the wedge head between the rollers. The rollers and plungers move outward and push the brake shoes against the drum causing friction to slow the vehicle.

(1) As the brake shoes contact the drum, the drum drags the shoes and the extended plungers around with it. This action causes the anchor plunger (at trailing end of each shoe) to reseal on its abutment. Brake torque is transmitted through the anchor plunger to the brake support.

(2) When the brake is released, the wedge spring returns the wedge and diaphragm to the released position. At the same time, the shoe return springs push the raised plungers back into their plunger housings.

*c. Automatic Adjusters.* The adjustable plunger of each brake actuator has an automatic adjustment feature. Helical teeth on the outside of the plunger sleeve engage with saw-tooth-type teeth on a spring-engaged adjusting pawl.

(1) As the brake is actuated, the plunger sleeve moves outward with the plunger. The teeth on the plunger sleeve lift the adjusting pawl against the spring.

(2) When the brake is released, all the parts return to their starting positions.

(3) As the brake lining wears, the plunger stroke and the resulting pawl lift gradually increases. Eventually, the pawl will climb over and fall into the next tooth space. This time, when the brake is released, the upright face of the pawl teeth causes the adjusting sleeve to rotate and advance the adjusting bolt.

(4) The automatic adjuster operates only when vehicle is moving forward.

*d. Brake Air System (Fig. 4-53).* Compressed air is transmitted from the towing vehicle through the service and emergency air lines. When the engine of the towing vehicle is running, air pressure of 90-120 psi is kept in the system through the emergency air line. Compressed air is routed into the rear reservoir through the emergency relay valve. From the rear reservoir, the air enters the front reservoir.

(1) The front reservoir is for the fail-safe brakes. A pressure protection valve between the two reservoirs maintains approximately 75 psi of air in the front reservoir for release of the fail-safe brakes.

(2) When there is enough reserve air in the front reservoir, the spring brakes can be released by opening a valve on the roadside of the semitrailer (para 2-4).

(3) A fill valve is installed on the roadside of the semitrailer to permit filling of the front reservoir (para 2-4a).

*e. Service Brake.* When the towing vehicle is attached, the foot brake operates the brakes on both the semitrailer and the towing vehicle.

(1) Applying the brake pedal delivers air through the service air line to the emergency relay valve.

(2) In response to the service signal, the emergency relay valve releases air from the rear reservoir to the brake chambers. Air pressure causes the wedge in each brake actuating assembly to move forward and push the brake shoes against the drum.

(3) Releasing the brake pedal stops the service signal to the emergency relay valve. The emergency relay valve closes the supply from the reservoir and releases air from the brake chambers.

*f. Emergency Relay Valve (Fig. 4-54).* This valve increases the speed at which the brakes apply and release. The relay valve is attached to the rear reservoir above the forward axle.

(1) The emergency relay valve releases air from the rear (primary) reservoir to all brake chambers in response to the service signal from the towing vehicle.

(2) The emergency relay valve will also cause the fail-safe brakes to apply automatically if the semitrailer breaks away from the towing vehicle.

*g. Fail-Safe Units (Fig. 4-55).* The fail-safe units are spring chambers which are assembled piggyback on the brake air chambers. One each is installed on the air chambers at the four corners of the tandem axle assembly. The fail-safe unit provides parking and emergency braking.

(1) Air pressure of approximately 65 psi is needed to release the fail-safe units.

(2) Loss of air pressure will release the heavy spring and push the piston against the diaphragm plate of the air chamber. This force is applied through the wedge assembly and plungers to the brake shoes.

(3) The fail-safe units can be manually released if air pressure is not available (para 2-4).

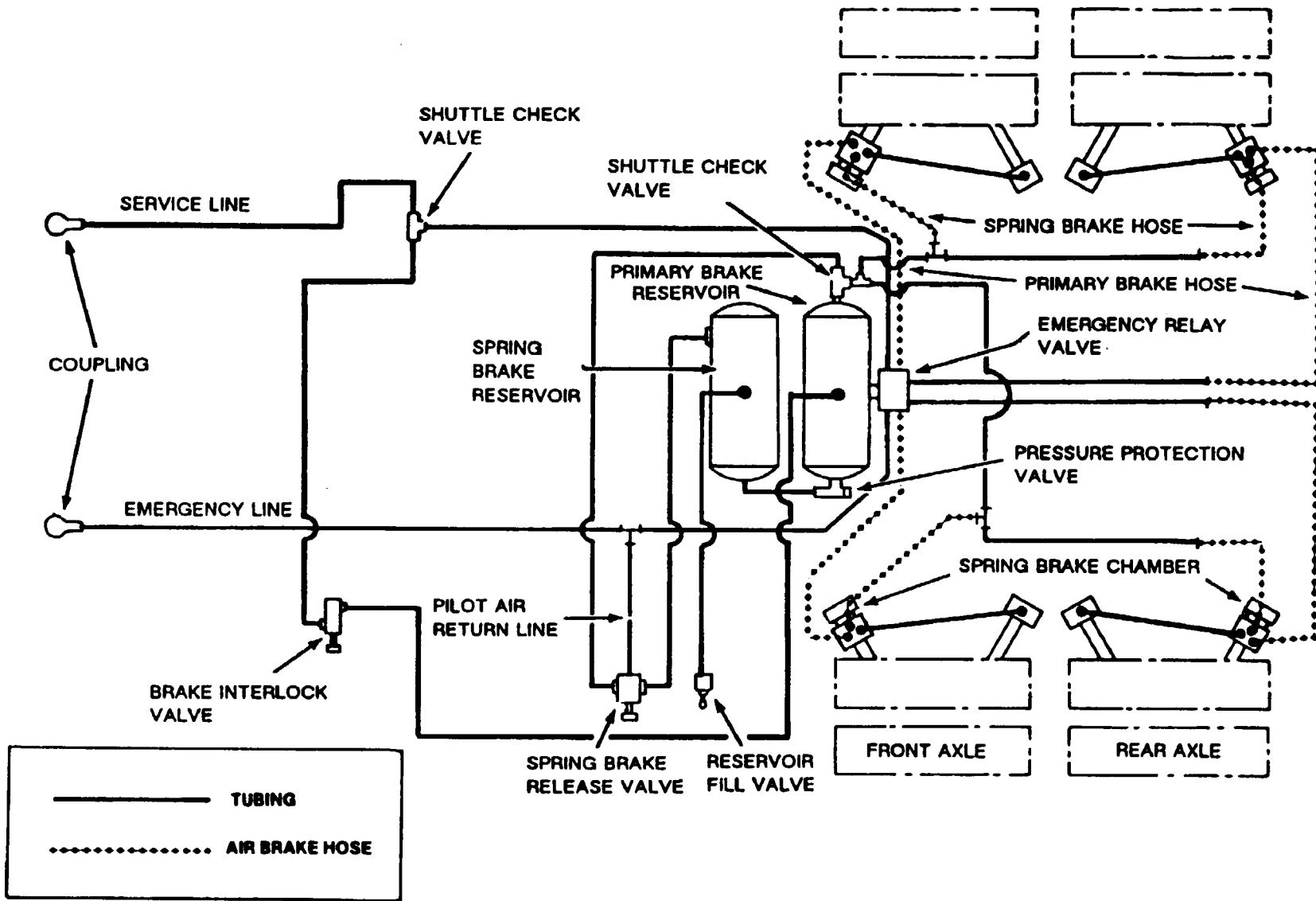
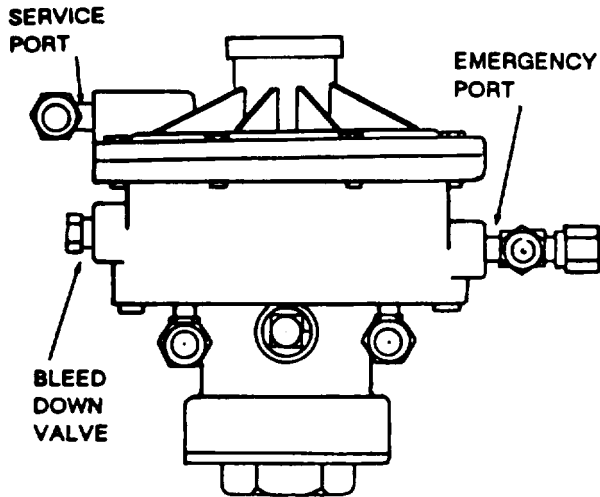

Figure 4-53. Brake Schematic (M967, M969, and M970 except M970 SN TC-0843, TC-0844, and TC-103 thru TC-178).

TA502378





TA099807

Figure 4-54. Emergency Relay Valve.

*h. Brake Interlock (M970 except M970 TC-0843, TC-0844, and TC-103 thru TC-178).* The brake interlock system is activated when the door on the hose reel cabinet is open. When actuated, the interlock valve sends air from the rear reservoir into the service air line. This gives a service signal to the emergency brake relay valve. The relay valve releases air from the rear reservoir to the brake air chambers to apply the brakes. Figures 4-53 and 4-56 show how the interlock system connects into the air brake system.

**4-32. General, M967A1, M969A1, and M970A1 Including M970 SN TC-0843, TC-0844, and TC-103 thru C-178.**

*a. Description.* The semitrailer brakes are air-operated cam-type brakes. Two brake camshafts, two slack adjusters,

and two brake chambers are assembled to the front and rear axle. The brake chamber movement through the slack adjuster causes the camshaft to rotate and force the brake shoes against the brake drum (fig. 4-57).

(1) Attached to the slack adjusters are two camshafts—one right-hand and one left-hand.

(2) The “S”-shaped part of the camshaft is positioned between the rollers on the brake shoes.

*b. Actuation.* When the brake is actuated, air is applied to the brake chambers and the diaphragm rod moves the slack adjusters rotating the brake camshaft against the two rollers on the brake shoes. This action forces the brake shoes against the brake drum using friction to slow or stop the vehicle. When the brake is released, spring action returns the brake shoes to release position.

*c. Brake Air System (Fig. 4-58).* Compressed air is transmitted from the towing vehicle through the service and emergency air lines. When the engine of the towing vehicle is running, air pressure of 90-120 psi is kept in the system through the emergency airline. Compressed air is routed into the rear reservoir through the emergency relay valve. From the rear reservoir, the air enters the front reservoir.

(1) The front reservoir is for the fail-safe brakes. A pressure protection valve between the two reservoirs maintains approximately 75 psi of air in the front reservoir for release of the fail-safe brakes.

(2) When there is enough reserve air in the front reservoir, the spring brakes can be released by opening a valve on the roadside of the semitrailer (para 2-4).

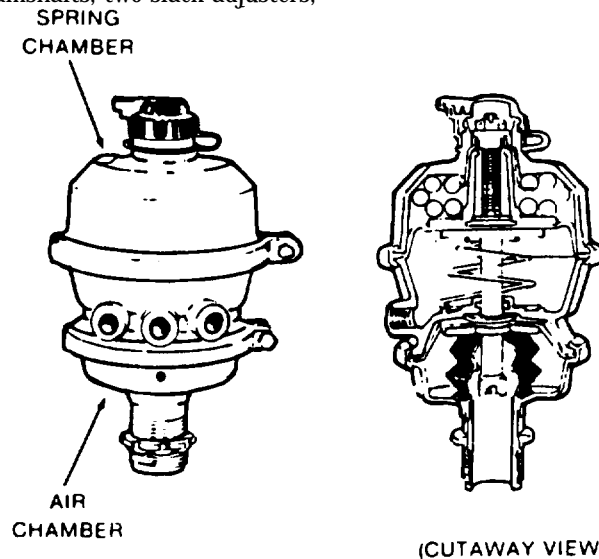

TA099808

Figure 4-55. Fail-Safe Unit (M967, M969, and M970 except M970 SN TC-0843, TC-0844, and TC-103 thru TC-178).

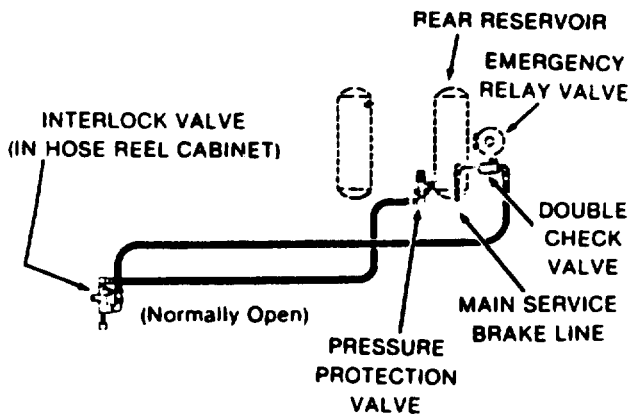

TA099809

Figure 4-56. Brake-Interlock (M970 and M970A1).

(3) A fill valve is installed on the roadside of the semitrailer to permit filling of the front reservoir (pars 2-4).

d. *Service Brake.* When the towing vehicle is attached the foot brake operates the brakes on both the semitrailer and the towing vehicle.

(1) Applying the brake pedal delivers air through the service line to the emergency relay valve.

(2) In response to the service signal, the emergency relay valve releases air from the rear reservoir to the brake chambers. Air pressure causes the camshaft

in each brake assembly to rotate and force the broke shoes against the brake drum.

(3) Releasing the brake pedal stops the service signal to the emergency relay valve. The emergency relay valve closes the supply from the reservoir and releases air from the brake chambers.

e. *Emergency Relay Valve* (Fig. 4-54). This valve increases the speed at which the brakes apply and release. The relay valve is attached to the rear reservoir above the forward axle.

(1) The emergency relay valve releases air from the rear (primary) reservoir to all brake chambers in response to the service signal from the towing vehicle.

(2) The emergency relay valve will also cause the fail-safe brakes to apply automatically if the semitrailer breaks away from the towing vehicle.

f. *Fail-Safe Units* (Fig. 4-57). The fail-safe units are spring chambers which are assembled piggyback on the brake air chambers. One each is installed on the air chambers at the four comers of the tandem axle assembly. The fail-safe unit provides parking and emergency braking.

(1) Air pressure of approximately 65psi is needed to release the fail-safe units.

(2) *Loss of air pressure* will release the heavy spring and push the piston against the diaphragm plate of the air chamber. This force is applied through the camshaft to the brake shoes.

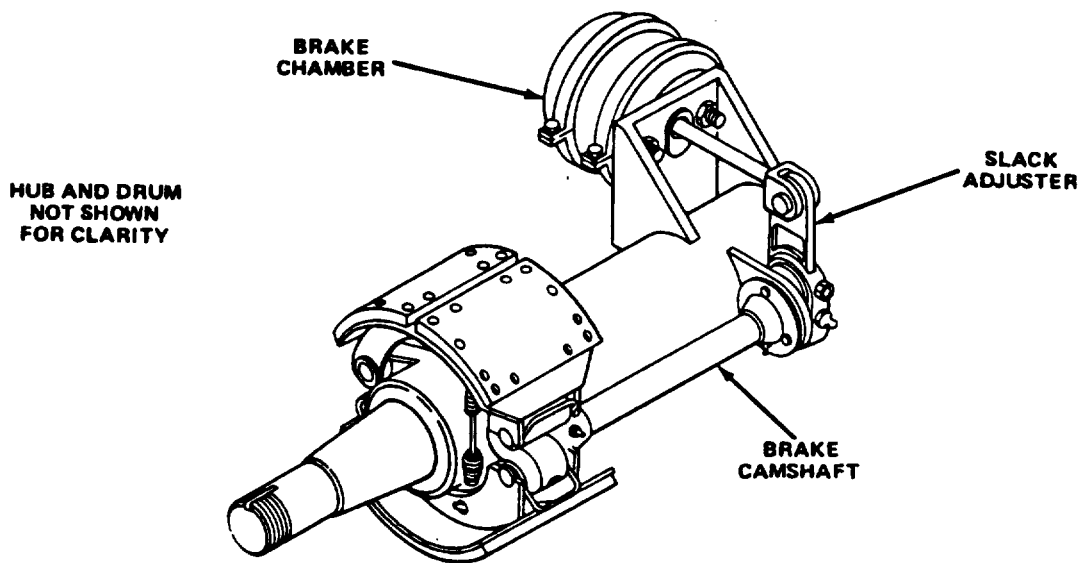

Figure 4-57. Brake Actuator Assembly (M967A1, M969A1, and M970A1 including M970 SN TC-0843, TC-0844, and TC-103 thru TC-178).

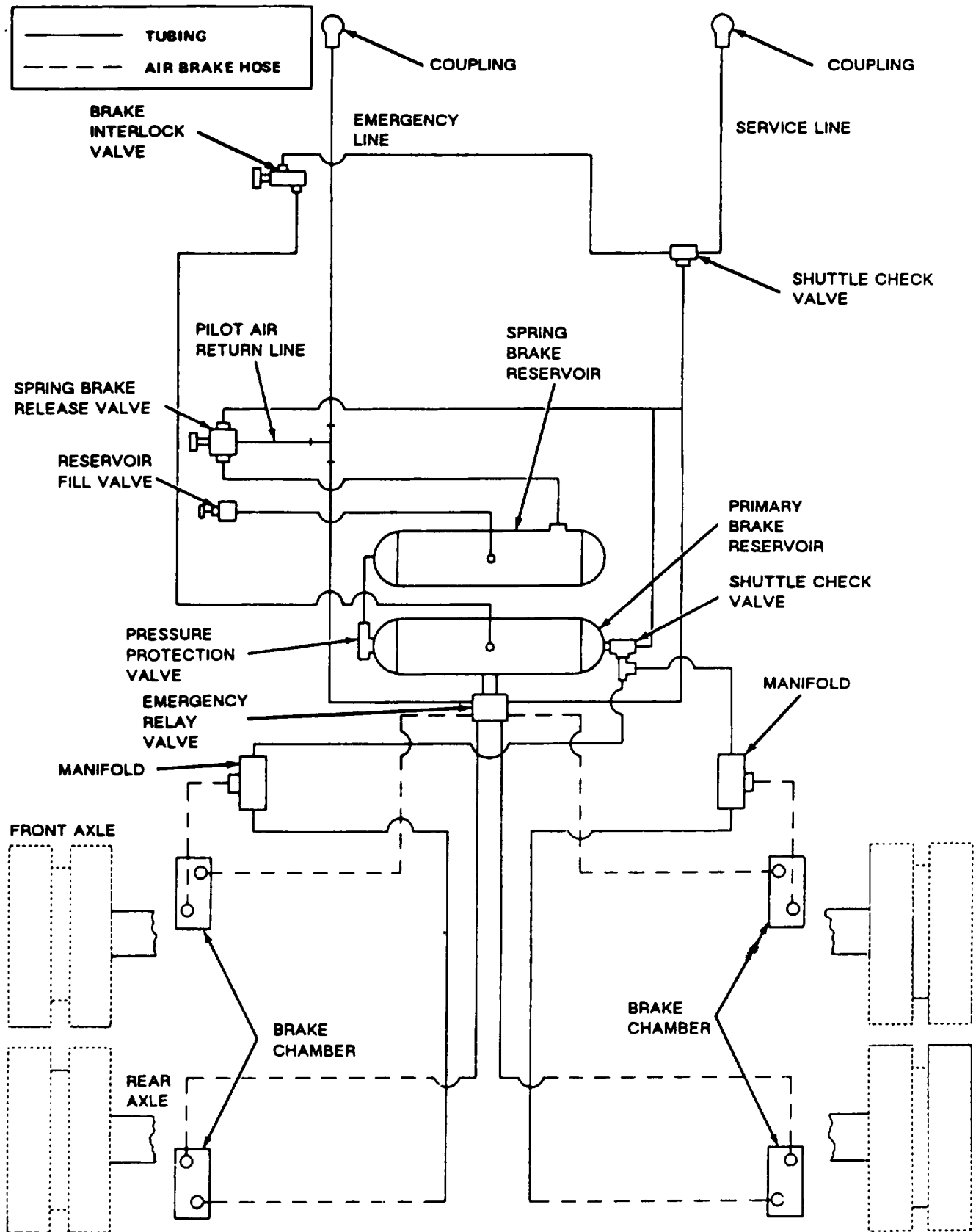

Figure 4-58. Brake Schematic (M967A1, M969A1, and M970A1 including M970 SN TC-0843, TC-0844, and TC-103 thru TC-178).

g. *Brake Interlock (M970A1 including M970 SN TC-0843, TC-0844, and TC-103 thru TC-178).* The brake interlock system is activated when the door on the hose reel cabinet is open. When actuated, the interlock valve sends air from the rear reservoir into the service air line. This gives a service signal to the emergency brake relay valve. The relay valve releases air from the rear reservoir to the brake air chambers to apply the brakes. Figures 4-56 and 4-58 show how the interlock system connects into the air brake system

h. *Slack Adjusters.* These convert linear motion of the brake chamber to rotating motion of the camshaft. The slack adjuster consists of a housing, two gears, and two gear covers. Brake adjustments are made through the slack adjuster.

**4-33. Service Brake Shoe Assemblies, M967, M969, and M970 except M970 SN TC-0843, TC-0844, and TC-103 thru TC-178.**

a. *Test and Adjustment.*

- (1) Jack up the semitrailer and lift all wheels off the ground. Block the frame securely.
- (2) Release the fail-safe units (pars 2-4).
- (3) Remove dust plugs from access slots at top and bottom of dust shield (fig. 4-59).

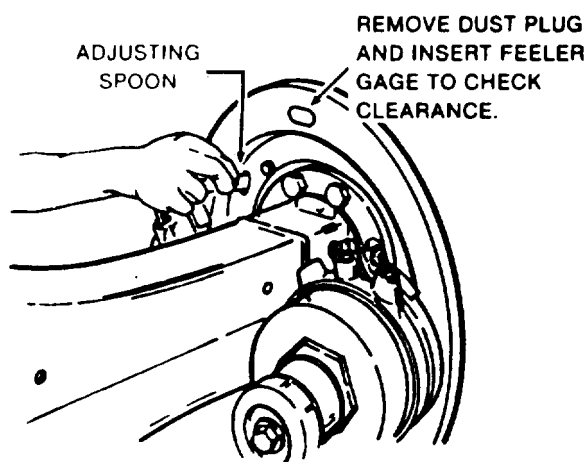

TA099810

**Figure 4-59. Adjusting Brake Lining-to-Drum Clearance.**

(4) Insert a feeler gage into the access slots and check brake drum to brake lining clearance. If clearance is between .040- and .060-inch, automatic adjusters are

operating and brakes are properly adjusted. If clearance is not between .040- and .060-inch, proceed to step (5).

**NOTE**

**If adjusting bolt starwheel will not turn using hand pressure, lightly tap the tool with a hammer.**

(5) Insert brake adjusting spoon or long thin screwdriver into slot to meet the starwheel on the adjusting bolt. The adjusting bolt has right hand threads. Turn the starwheel counterclockwise to reduce brake lining-to-drum clearance.

(6) Back off the starwheel until you get a very slight drag on the drum. Check brake lining clearance again (step (4)).

(7) Repeat steps (4) through (6) above for the other shoe on brake.

(8) Repeat steps (1) through (6) for all brake assemblies.

b. *Inspection and Replacement.*

(1) Remove wheel and drum assembly (pars 4-49).

(2) Inspect brake linings for damage and wear. New lining has approximately 1/2-inch of stock above center rivets and approximately 1/4-inch of stock above end rivets. Replace brake shoe if lining is damaged or is worn within .030-inch of rivet heads. By recording lining wear between scheduled annual brake maintenance periods, expected wear can be calculated. Shoes with linings that will not last until the next scheduled maintenance interval should be replaced.

c. *Removal.*

(1) Remove hub, drum, and wheels (para 4-49).

(2) Turn the automatic adjusters with a brake adjusting spoon or a long thin screwdriver clockwise until the wedge brake plungers are fully contracted.

(3) Remove brake shoe return springs using brake spring pliers.

(a) Unhook top hook of both return springs.

(b) Remove springs.

(4) Remove brake shoes being careful not to disturb the position of the wedge brake parts.

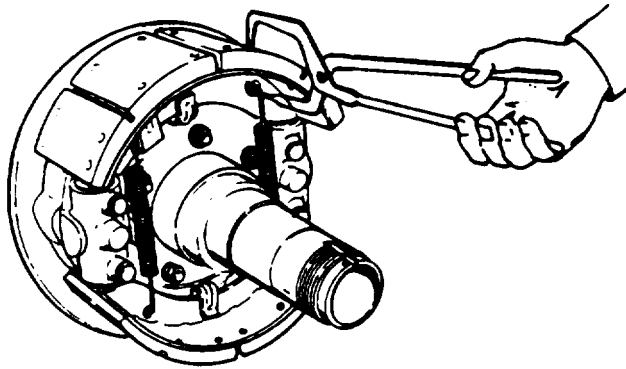

TA099811

Figure 4-60. Remove Brake Shoes.

**CAUTION**

Use an authorized suitable solvent to clean the brake components. **DO NOT** use gasoline or hot water solutions. Gasoline coats the metal parts and prevents grease from adhering. Water causes etching and rust. If parts are not dried completely.

(5) Clean brake shoe return springs, backing plate, and wedge assemblies.

(6) Do not remove the dust shield unless damage is evident.

*d. Repair.*

(1) Service the plungers and brake adjusting parts (para 4-36).

(2) Service the brake wedge assemblies (para 4-35).

(3) Refer replacement of brake linings and refacing of the drums to direct support maintenance.

*e. Installation.*

(1) It is imperative that each brake be assembled as shown in figure 4-61 in relation to forward wheel rotation. Note the position of the solid plunger and the adjusting plunger. Also note the position of the long radius on the shoe web.

(2) The anchor (solid) plunger must be positioned at the trailing end of each shoe. The adjustable plungers must be installed at the leading end of the shoes. This lets the brake torque be absorbed by the anchor plunger during forward wheel rotation.

(3) The long radius on the brake shoe should be engaged with the adjustable plungers.

(4) Install new return springs whenever new or relined brake shoes are being installed.

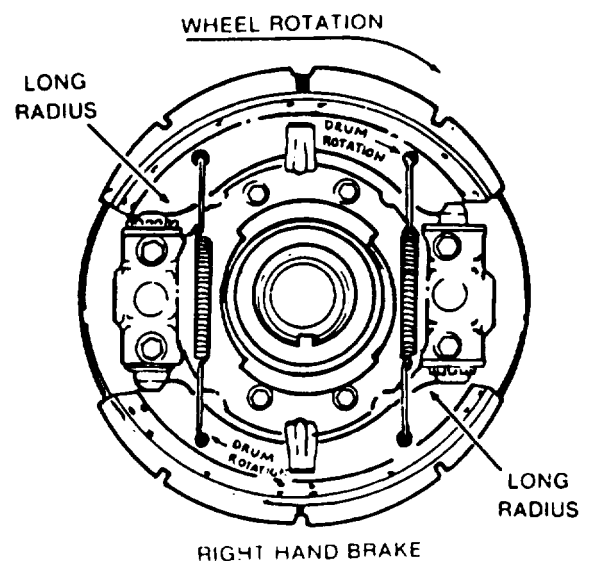
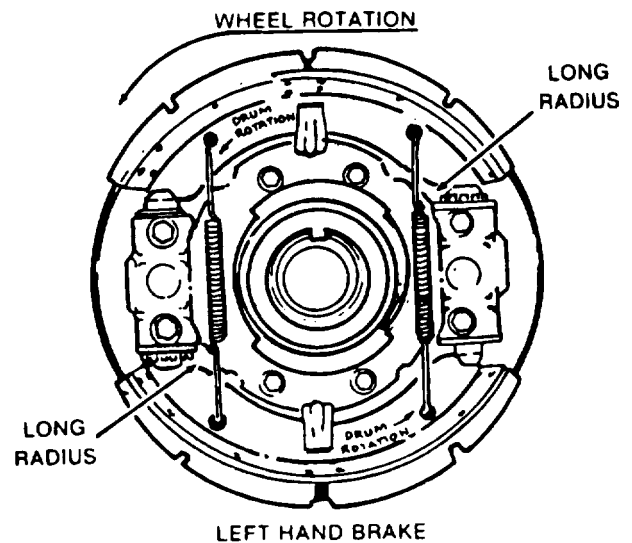

Figure 4-61. Plunger and Shoe Position (M967, M969, and M970 except M970 SN TC-0843, TC-0844, and TC-103 thru TC-178).

**4-34. Service Brake Shoe Assemblies, M987A1, M969A1, and M970A1 including M970 SN TC-0843, TC-0844, and TC-103 thru TC-178.**

*a. Test and Adjustment.*

(1) Jack up semitrailer to lift all wheels off the ground. Block the frame securely.

(2) Release all spring forces from slack adjuster and camshaft by applying air to the air brake chamber.

(3) Check that the wheels rotate freely.

(4) Check yoke adjustment. Dimension from outside of nonpressure housing to center of clevis pin must be 5.56-inches (fig. 4-62).

(5) Apply a 9/16-inch wrench to worm shaft hex head and push in against the slack adjuster to unlock the worm shaft.

(6) Turn the hex head of the worm shaft clockwise on slack adjuster until wheels cannot be turned.

(7) Back off the worm shaft until the wheel turns freely.

(8) Repeat steps (1) through (7) for all four brake assemblies.

*b. Inspection and Replacement.*

(1) Remove wheel and drum assembly (para 4-49).

(2) Inspect brake linings for damage and wear. New lining has approximately 1/2-inch of stock above center rivets and approximately 1/4-inch of stock above end rivets. Replace brake shoe if lining is damaged or worn within .030-inch of rivet heads. By recording lining wear between scheduled annual brake maintenance periods, expected wear can be calculated. Shoes with linings that will not last until the next scheduled maintenance interval should be replaced.

*c. Removal.*

(1) Remove wheel and drum assembly (para 4-49).

(2) Loosen spider bolt (fig. 4-63).

(3) Using broke spring pliers, remove broke shoe return spring.

(4) Remove anchor pin retaining rings and anchor pin washers.

(5) Drive upper and lower anchor pins from rear of brake shoe.

(6) Remove brake shoes.

(7) Remove roller retainers and rollers from brake shoes.

(8) Remove spring pins from brake shoes.

(9) Remove brake spider nut, washer, and bolt.

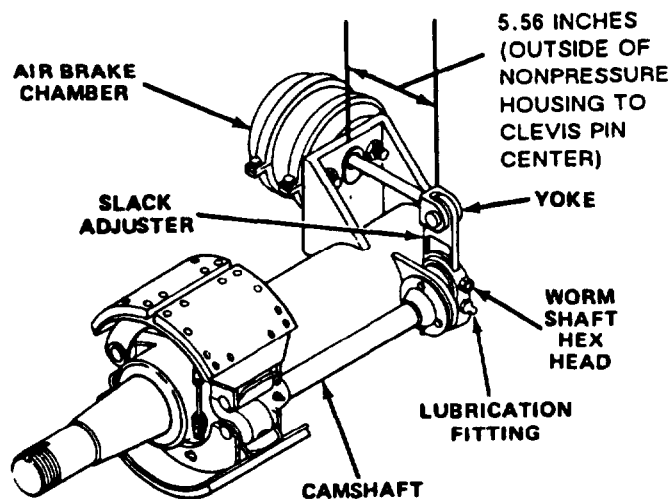

TA504714

**Figure 4-62. Adjustment of Yoke and Slack Adjuster (M967A1, M969A1, and M970A1 including M970 SN TC-0843, TC-0844, and TC-103 thru TC-178).**

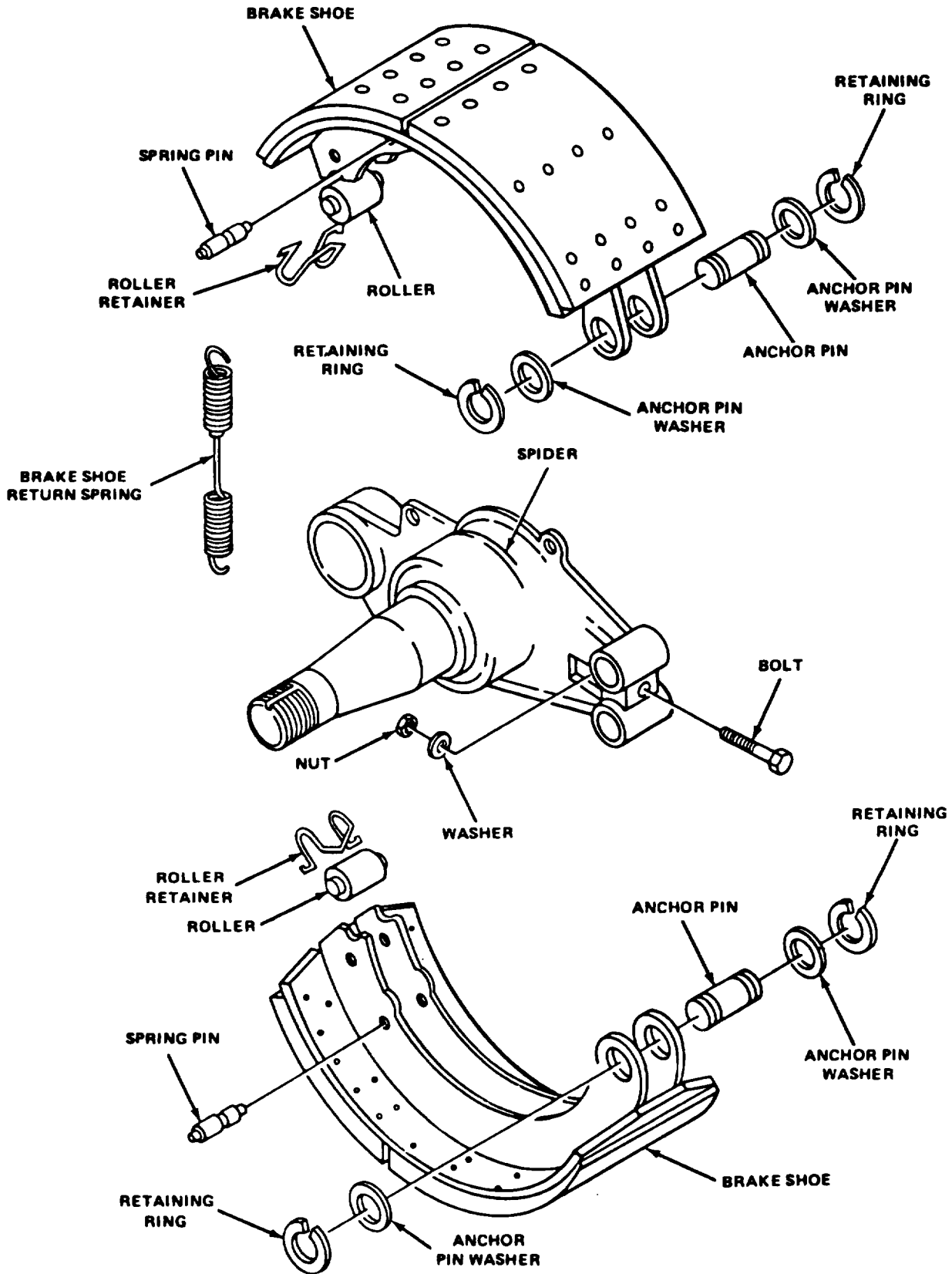

TA221207  
 Figure 4-63. Removing and Installing Brake Shoes (M967A1, M969A1, and M970A1 including M4970 SN TC-0843, TC-0844, and TC-103 thru TC-178).

**WARNING**

- **Dry cleaning solvent P-D-680 is toxic and flammable. Always wear protective goggles and gloves, and use only in a well-ventilated area. Avoid contact with skin, eyes, and clothes, and DO NOT breathe vapors. DO NOT use near open flame or excessive heat. The solvent's flash point is 100°F-138°F (38°C-59°C). If you become dizzy while using cleaning solvent, immediately get fresh air and medical help. If solvent contacts eyes, immediately wash your eyes with water and get medical aid.**
- **Compressed air used for drying or clearing purposes must not exceed 30 psi (207 kPa). Wear protective clothing (goggles and gloves) and use caution to avoid injury to personnel.**

(10) Clean anchor pins, rollers, roller retainers, spring pins, and brake shoe return spring with dry cleaning solvent (item 11, Appendix E). Dry the parts with low pressure compressed air.

(11) Refer replacement of brake linings and refacing of the drums to direct support maintenance.

*d. Installation.*

(1) Install spider bolt, washer, and nut. Do not tighten (fig. 4-63).

(2) Install spring pins on brake shoes.

(3) Install rollers and roller retainers on brake shoes.

(4) Place brake shoes into position on brake spider, and install upper and lower anchor pins and anchor pin washers.

(5) Install anchor pin retaining rings on upper and lower anchor pins.

(6) Using brake spring pliers, install brake shoe return spring.

(7) Tighten spider nut and bolt to 100-120 lb.-ft.

*e. Assembly and Adjustment.*

(1) Install wheel and drum assembly (para 4-49).

(2) Adjust slack adjuster (para 4-34).

- 4-35. **Brake Wedge Assembly, M967, M969, and M970 except M970 SN TC-0843, TC-0844, and TC-103 thru TC-178 (Fig. 4-64).**

**CAUTION**

**Before removing any wedge actuator or attempting to release spring brake or removing a clamp band, block wheels to prevent vehicle movement.**

*a. Removal.*

(1) Remove brake air chamber (paras 4-37 and 4-39),

(2) Remove wedge assembly by pulling it straight out of plunger housing.

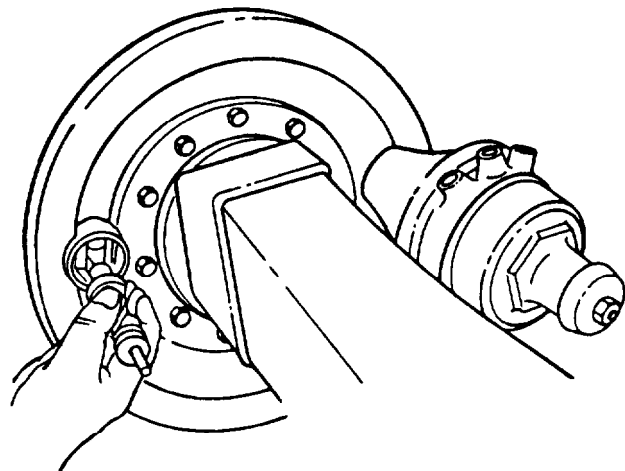

TA502350

**Figure 4-64. Wedge Assembly Removal or Installation (M967, M969, and M970 except M970 SN TC-0843, TC-0844, and TC-103 thru TC-178).**

*b. Inspection.*

**WARNING**

**Compressed air used for drying or cleaning purposes must not exceed 30 psi (207 kPa). Wear protective clothing (goggles and gloves) and use caution to avoid injury to personnel.**

(1) Clean wedge assembly thoroughly with mild soap solution and dry with low pressure compressed air.

(2) Inspect for damaged rubber boot, roller retaining cage, rollers, or broken spring.

(3) Replace wedge assembly if damaged or broken.



c. Repair. No repair is authorized. If damage is found, replace the wedge assembly.

d. *Installation.*

(1) Wipe plunger housing and wedge assembly with clean rag.

(2) Install wedge assembly into the plunger housing. It maybe necessary to turn wedge assembly to engage the tabs (fig. 4-65) in the plunger housing. Check for correct roller-plunger engagement by:

(a) Observing that the ears on the roller retaining cage are in corresponding slots in wedge bore of plunger housing.

(b) Pushing on wedge rod by hand while checking for plunger and brake shoe lift.

(c) When properly installed, the wedge rod standout is 2¼-inches from plunger housing. Measure the standout of the wedge rod from the end of the threaded plunger housing bore.

(3) Install brake chamber (paras 4-37 and 4-39).

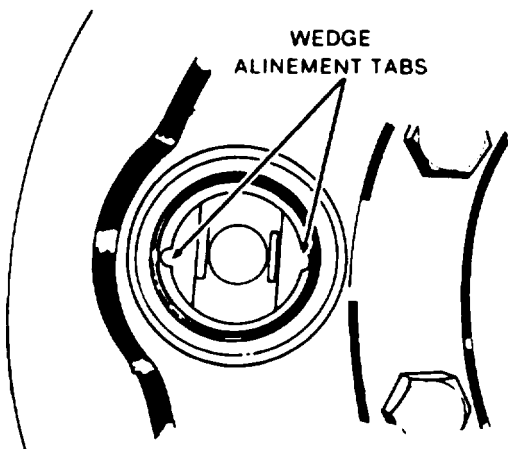

TA099814

Figure 4-65. Brake Wedge Alinement Tabs in Plunger Housing (M967, M969, and M970 except M970 SN TC-0843, TC-0844, and TC-103 thru TC-178).

**4-36. Brake Plungers and Brake Adjusting Parts, M967, M969, and M970 except M970 SN TC-0843, TC0844, and TC-103 thru T-178.**

a. *Service.* The plungers and adjusting parts should be serviced by following procedures c through e below whenever the shoes have been removed.

b. *Removal of Adjusting Plunger Assembly.*

(1) Remove brake shoe assemblies (para 4-33).

(2) Remove brake chamber(s) (paras 4-37 and 4-39).

(3) Remove hollow capscrew, gasket, and pawl spring from side of plunger housing (fig. 4-66). If the pawl does not come out with spring, use a small magnet to remove the pawl.

(4) Pry the plunger seal loose. Remove the adjusting bolt, seal, and adjusting sleeve as an assembly. Remove the adjusting plunger.

c. *Removal of Anchor (Solid) Plunger.*

(1) Remove the guide screw and gasket from side of plunger housing (fig. 4-66).

(2) Remove plunger and seal assembly.

d. *Inspection and Repair.*

**WARNING**

- **Dry cleaning solvent P-D-680 Is toxic and flammable. Always wear protective goggles and gloves, and use only In a well-ventilated area. Avoid contact with skin, eyes, and clothes, and DO NOT breathe vapors. DO NOT use near open flame or excessive heat. The solvent's flash point is 100°F-138°F (38°C-59°C). If you become dizzy while using cleaning solvent, Immediately get fresh air and medical help. If solvent contacts eyes, immediately wash your eyes with water and get medical aid.**
- **Compressed air used for drying or cleaning purposes must not exceed 30 psi (207 kPa). Wear protective clothing (goggles and gloves) and use caution to avoid injury to personnel.**

(1) Thoroughly clean all metal parts with dry cleaning solvent (item 11, Appendix E). Dry the parts with low pressure compressed air.

**CAUTION**

**DO NOT use dry cleaning solvent to clean any rubber parts. Damage to parts would result.**

(2) Thoroughly clean plunger seals and gaskets with mild soap solution and dry with low pressure compressed air. Use wire brush on plunger parts and adjusting bolt threads, if required, to remove caked on dirt and corrosion.

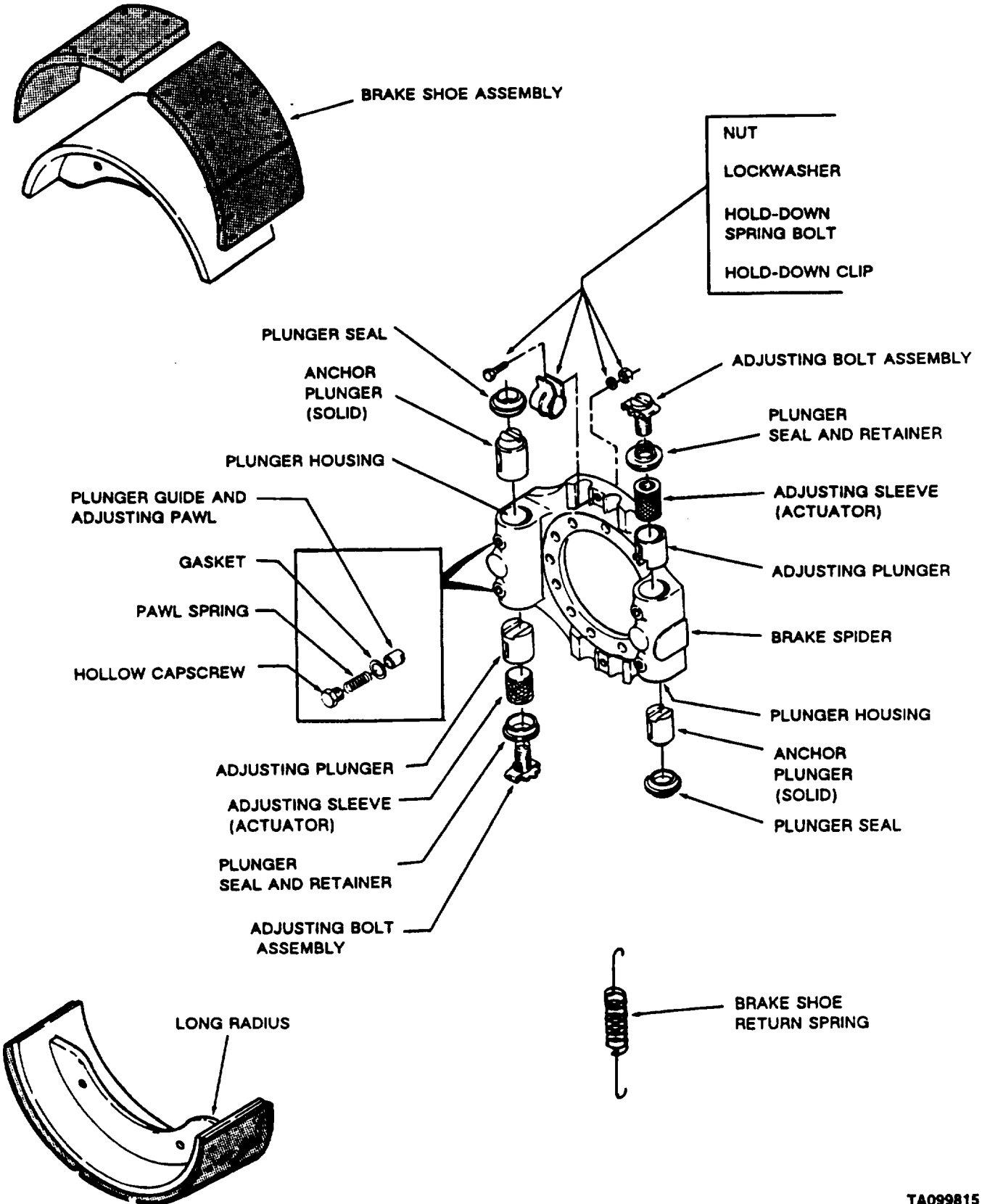

TA099815

Figure 4-66. Brake Shoe Assembly and Adjusting Pans (M967, M969, and M970 except M970 SN TC-0843, TC-0844, and TC-103 thru TC-178).

(3) Inspect plunger seals and gaskets for damage, cuts, or deterioration.

(4) Inspect plungers for rust, nicks, pits, or grooves.

(5) Check for burrs on nose of anchor plunger. Remove burrs with a fine file or crocus cloth. A bright, shiny surface where wedge roller contacts the plunger surface is normal.

(6) Check threads of adjusting bolt for damage.

(7) Replace all parts which are not in good condition.

e. *Installation of Anchor (Solid) Plunger.*

**CAUTION**

**DO NOT assemble seals into plunger housing first. This will result in complete lack of sealing of internal plunger housing components.**

**NOTE**

**Each plunger housing assembly has one adjusting plunger and one anchor (solid) plunger. The anchor plunger is marked on the slotted end, "R" for right-hand brakes and "L" for left-hand brakes. DO NOT mix at assembly.**

(1) The anchor plunger and seal is serviced as an assembly. Refer seal replacement to direct support maintenance.

(2) Install plunger and seal assembly into plunger housing in the following manner (fig. 4-66).

(a) Coat plunger bore with grease (item 17, Appendix E).

(b) Coat entire plunger with grease (item 17, Appendix E). Also pack the cavity behind the seal assembly.

(c) Insert plunger and seal assembly into housing with plunger keyway slot aligned with guide hole in plunger housing. The plunger must go all the way into the plunger bore and seat on the bosses at bottom of the plunger housing.

(d) Seat the plunger seal assembly in plunger housing with seal driver (fig. 4-67). A 1¾-inch wrench socket and rawhide mallet can also be used. Ensure that the seal is centered over the seal retainer to prevent damage to seal assembly.

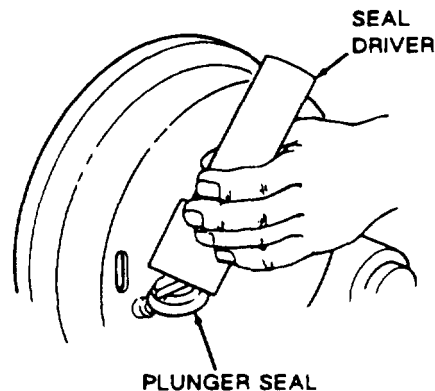

TA502351

**Figure 4-67. Seating Plunger Seal in Housing (M967, M969, and M970 except M970 SN TC-0843, TC-0844, and TC-103 thru TC-178).**

(3) Assemble gasket and guide screw (fig. 4-66) into guide hole in plunger housing. Ensure that the end of guide screw enters keyway slot in plunger so anchor plunger can slide freely in housing bore. Tighten guide screw to 15-20lb.-ft.

f. *Installation of Adjusting Plunger Assembly (Fig. 4-68).*

**CAUTION**

**DO NOT assemble seals into plunger housing first. This will result in complete lack of sealing of internal plunger housing components.**

(1) Coat the inside and outside surfaces of both the adjusting plunger and the adjusting sleeve with grease (item 17, Appendix E). Also coat the plunger bore in the housing with grease.

(2) Put the adjusting plunger into the plunger housing. Make sure the plunger goes all the way to bottom of bore and seats on the bosses. Aline keyway slot in plunger with guide hole in plunger housing.

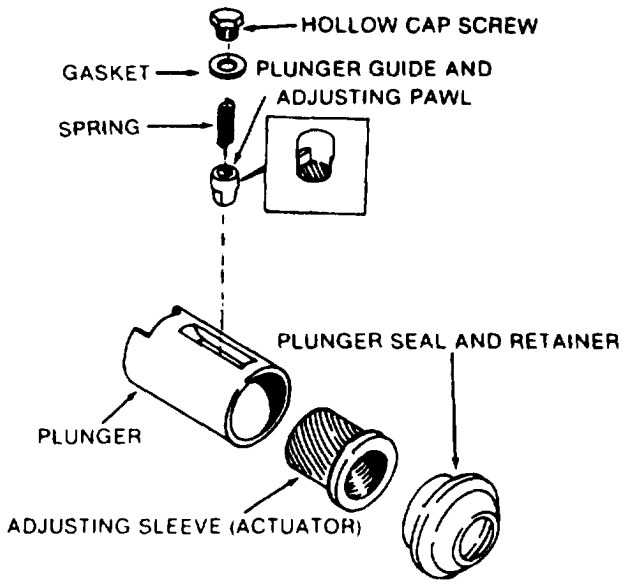

TA099817

Figure 4-68, Adjusting Plunger Assembly (M967, M969, and M970 except M970 SN TC-0843, TC-0844, and TC-103 thru TC-178).

**NOTE**

The hollow adjusting pawl has teeth on one end, flats on the side, and a chamfered edge on the other end. Coat the hollow adjusting pawl with grease (Item 17, Appendix E) and insert it into the guide hole, teeth first, and with chamfer toward the brake shoe. This aligns the pawl with the actuator teeth and the flats with the keyway slot. Ensure that pawl is all the way into the slot in plunger housing.

(3) Install adjusting pawl. Push pawl in flush with the inside of plunger. Hold the pawl in this position with a small screwdriver while you install the adjusting sleeve. Seat the sleeve on bottom of adjusting plunger.

(4) Install spring, gasket, and hollow capscrew. Tighten capscrew finger tight. Proper meshing of the pawl and sleeve teeth can now be double checked. Apply grease (item 17, Appendix E) to threads on adjusting bolt. Turn the adjusting bolt into the adjusting sleeve until it bottoms. A clicking sound and ratcheting feel will indicate meshing of teeth. Now turn the adjusting bolt out three turns. If there is no clicking sound or ratcheting feel, the pawl is properly meshed. Tighten hollow capscrew to 15-20 lb.-ft., and unscrew adjusting bolt from adjusting sleeve. If pawl is not properly meshed, repeat steps (2) and (3).

(5) Pack a small amount of grease (item 17, Appendix E) into the underside of single lip plunger seal and seal lips. Assemble the seal over the adjusting sleeve in the plunger housing. Push the seal over end of the adjusting sleeve until the inner lip enters seal groove. Check by lightly pulling up on seal. Seat the plunger seal assembly (fig. 4-67) in the plunger housing with seal driver or a 1 3/4-inch wrench socket and rawhide mallet.

(6) Apply grease (item 17, Appendix E) to threads of adjusting bolt (fig. 4-66). Carefully push the adjusting bolt through the seal and thread it into the adjusting sleeve. Be careful not to damage the seal. Turn the adjusting bolt in until head of bolt almost touches the seal. Do not bottom the bolt on the seal.

*g. Assembly and Adjustment.*

- (1) Install brake shoe assemblies (para 4-33).
- (2) Install wheels hubs, and drum (para 4-49).
- (3) Install brake air chambers (para 4-39).
- (4) Check and adjust the brake lining-to-drum clearance (para 4-33).

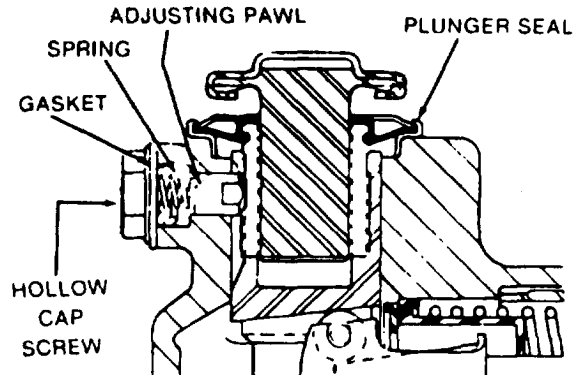

Figure 4-69. Cross-Section of Plunger Housing Showing Installation of Adjusting Plunger (M967, M969, and M970 except M970 SN TC-0843, TC-0844, and TC-103 thru TC-178).

**4-37. Brake Air Chamber (Standard) Test and Replacement, M967, M969, and M970 except M970 SN TC-0843, TC-0844, and TC-103 thru TC-178 (Fig. 4-70).**

*a. Test.*

- (1) With towing vehicle connected and vehicle brakes applied, coat the flanges and connections on the air chamber with soapy water.

(2) Check for leakage indicated by bubbles. No leakage is permissible.

**CAUTION**

**DO NOT overtighten clamp on air chamber. Maximum torque should be 20-25 lb.-ft. Over-tightening will distort the flange and cause more leakage.**

(3) If leakage is found at flange, tighten the clamp. If leakage is found at connections, tighten fittings.

(4) After initial brake application forces out a small amount of air, no air should be expelled from the air chamber. If air continues to exhaust, repair or replacement of the air chamber is necessary.

*b. Removal.*

(1) Disconnect brake hoses from brake chambers or relay valve.

(2) Remove U-bolt and two nuts securing chamber to bracket.

(3) Use adrift (fig. 4-70), or other blunt tool, and hammer to loosen the collet nut.

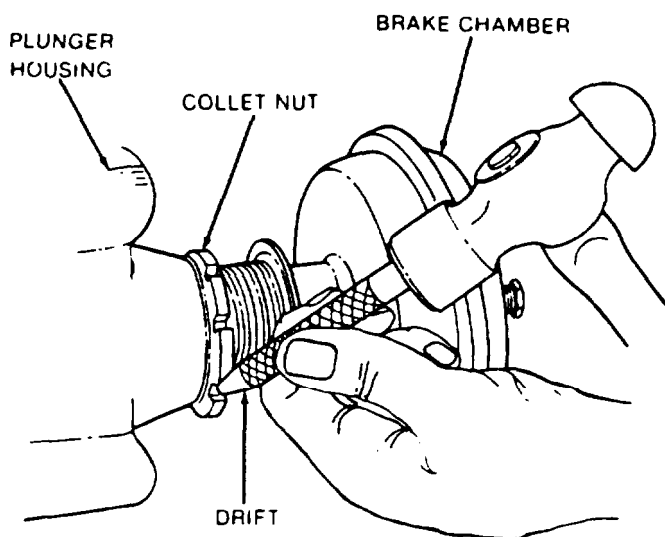

TA502352

**Figure 4-70. Removing Brake Chamber (M967, M969, and M970 except M970 SN TC-0843, TC-0844, and TC-103 thru TC-178).**

**NOTE**

**It may be necessary to remove the whole brake assembly from the axle before unscrewing the brake chamber, due to possible bracket interference.**

(4) Remove brake chamber by unscrewing it from plunger housing.

(5) At this time the wedge assembly can be removed for inspection or replacement (para 4-35).

*c. Repair.* Refer repair of brake chamber to direct support maintenance.

*d. Installation.*

(1) Check position of the wedge in plunger housing to make certain wedge assembly is properly seated (para 4-35).

(2) Thread collet nut (fig. 4-70) onto housing tube. Apply a non-hardening sealer (item 25, Appendix E) to the first three threads of the housing tube.

(3) With collet nut loose, turn the brake chamber into the plunger housing until it bottoms.

(4) Aline connection ports with brake lines, if necessary, by unscrewing brake chamber not more than one full turn.

(5) Install U-bolt and two nuts to secure brake chamber to bracket.

(6) Connect brake line.

(7) Make and hold a full pressure brake application. Hand tighten the collet nut. With a drift and hammer tighten collet nut 1½-teeth or additional 3/18 of a turn. Release brake pressure.

(8) Check for leaks at flange and connections (step a).

**4-38. Brake Air Chamber Test and Replacement, M967A1, M969A1, and M970A1 including M970 SN TC-0843, TC-0844, and TC-103 thru TC-178 (Fig. 4-71).**

*a. Test.*

(1) With towing vehicle connected and vehicle brakes applied, coat the flanges and connections on the air chamber with soapy water.

(2) Check for leakage indicated by bubbles. No leakage is permissible.

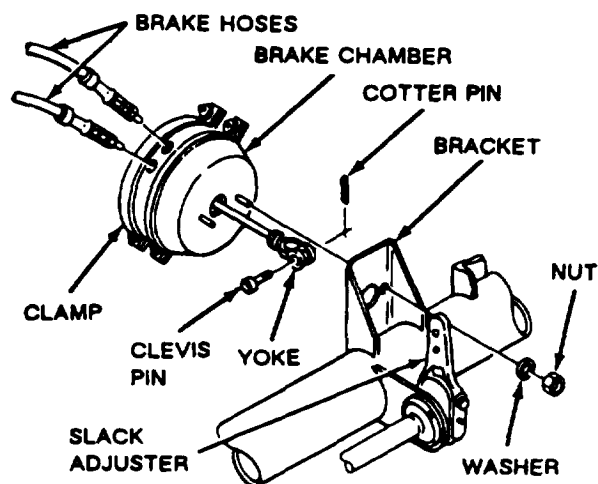

TA221208

Figure 4-71. Removing and Installing Brake Chamber (M967A1, M969A1, and M970A1 including M970 SN TC-0843, TC-0844, and TC-103 thru TC-178).

**CAUTION**

**DO NOT overtighten clamp on air chamber. Maximum torque should be 20-25 lb.-ft. Over-tightening will distort the flange and cause more leakage.**

(3) If leakage is found at flange, tighten the clamp. If leakage is found at connection% tighten fittings.

(4) After initial brake application forces out a small amount of air, no air should be expelled from the air chamber. If air continues to exhaust, replacement of the air chamber is necessary.

*b. Removal.*

(1) Open drain valves on the air reservoirs and allow air to bleed off (fig. 4-79).

(2) Disconnect two brake hoses from brake chamber (fig. 4-71).

(3) Remove cotter pin and clevis pin securing yoke to slack adjuster.

(4) Remove two nuts and two washers securing brake chamber to bracket.

(5) Remove brake chamber.

*c. Repair. No repair of brake chamber is authorized.*

*d. Installation.*

(1) Place brake chamber in position on bracket (fig. 4-71).

(2) Install two washers and two nuts to secure brake chamber to bracket.

(3) Check yoke adjustment (para 4-34).

(4) Install clevis pin and cotter pinto secure yoke to slack adjuster.

(5) Connect two brake hoses to brake chamber.

(6) Close drain valves on air resevoirs (fig. 4-79).

(7) Pressurize air brake system and check for leaks.

**4-39. Brake Chamber—Fail-Safe Test and Replacement, M967, M969, and M970 except M970 SN TC-0843, TC-0844, and TC-103 thru TC-178.**

*a. Test.* Perform leakage test (para 4-37). The fail-safe unit will also be pressurized when the emergency line is connected.

*b. Replacement of Fail-Safe Unit.*

(1) Manually cage the spring in the fail-safe unit (para 2-4).

(2) Release air pressure by opening drain valves on both air reservoirs (fig. 4-79), then disconnect air lines and tag for identification at installation.

(3) Tag brake hoses and disconnect them from brake chambers and relay valve.

(4) Remove nut and capscrew from clamp ring which secures fail-safe unit to brake chamber (fig. 4-72).

(5) Spread the clamp ring. Hold the diaphragm on the non-pressure half and remove the fail-safe unit.

(6) Carefully install new fail-safe unit over diaphragm on non-pressure housing.

**CAUTION**

**DO NOT overtighten clamp on air chamber, Maximum torque should be 20-25 lb.-ft. Over-tightening will distort the flange and cause leakage.**

(7) Install clamp ring, with capscrew, nuts, and identification tag (fig. 4-72). Position the ports on the

fail-safe unit to align with brake lines. Tighten clamp screw to 20-25 lb.-ft. Do not overtighten.

- (8) Reconnect air hoses to brake chamber.
- (9) Manually release spring in fail-safe unit.

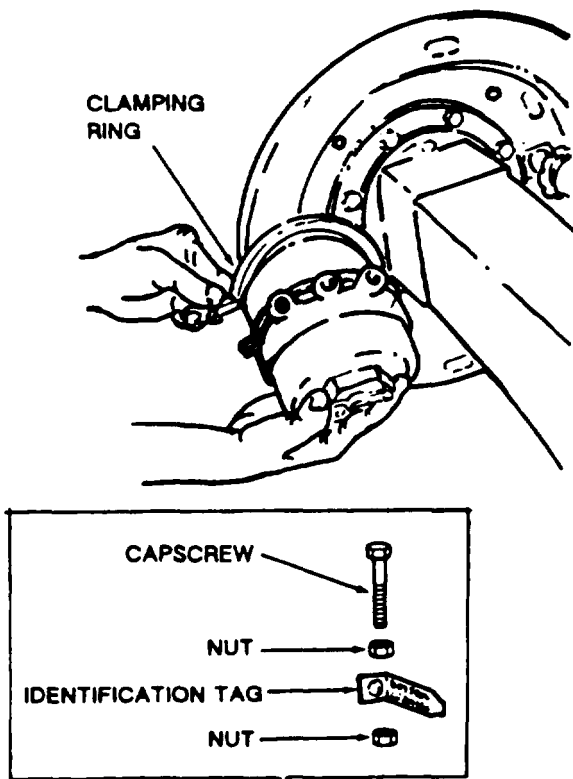

TA099820

**Figure 4-72. Removing Brake Chamber (M967, M969, and M970 except M970 SN TC-0843, TC-0844, and TC-103 thru TC-178).**

c. *Repair of Fail-Safe Unit.*

**WARNING**

Do not attempt to repair brake chamber fail-safe unit. It is dangerous because of high spring compression. No repair is authorized for fail-safe unit.

d. *Removal of Brake Chamber.*

- (1) Cage the spring in the air chamber unit (para 2-4).
- (2) Release air pressure by opening drain valves on both air reservoirs (fig. 4-79).
- (3) Tag and disconnect air lines from brake chamber and air chamber unit.

(4) Remove rear clamping band (fig. 4-73) securing air chamber unit to brake chamber and remove air chamber unit.

(5) Use a drift and hammer to loosen collet nut (fig. 4-70).

(6) Remove brake chamber and air chamber unit by unscrewing the assembly from the plunger housing.

(7) At this time, the wedge assembly can be removed for inspection or replacement (para 4-35).

e. *Repair.* Refer repair of brake chamber to direct support maintenance.

f. *Installation of Brake Chamber and Air Chamber Unit*

(1) Clean and install wedge assembly (if removed) into plunger housing (para 4-35). Check position of wedge in plunger housing to make certain wedge assembly is properly seated

(2) Make sure the spring in the air chamber unit is caged.

(3) Thread collet nut onto housing tube. Apply non-hardening sealer (item 25, Appendix E) to the first three threads of housing tube.

(4) With collet nut loose, turn the brake chamber into plunger housing until it bottoms.

(5) Replace the air chamber unit on the brake chamber. Clamp in place with clamp ring, using a nut and capscrew to secure clamp.

(6) Align connection ports with brake lines, if necessary, by unscrewing brake chamber not more than one full turn.

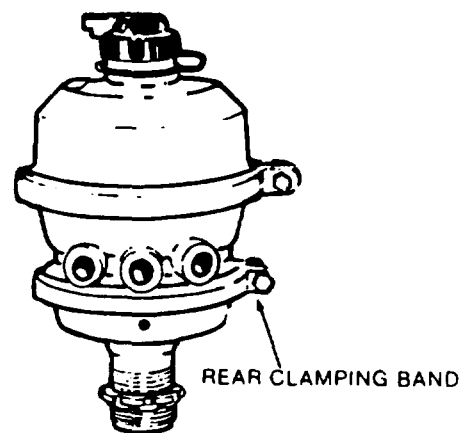

**Figure 4-73. Brake Chamber and Air Chamber Unit (M967, M969, and M970 except M970 SN TC-0843, TC-0844, and TC-103 thru TC-178).**

(7) Connect brake lines.

(8) Make and hold a full pressure application (fall air tank and apply service brakes). Hand tighten the collet nut. With a drift and hammer tighten nut 1½-teeth or additional 3/16 of a turn. Release service brakes.

(9) Uncage spring in fail-safe unit.

**4-40. Brake Chamber-Fail-Safe Unit Test and Replacement, M967A1, M969A1, and M970A1 including M970 SN TC-0843, TC-0844, and TC-103 thru TC-178.**

a. *Test.* Perform leakage test (para 4-38). The fail-safe unit will also be pressurized when the emergency line is connected.

b. *Replacement of Fail-Safe Unit.*

(1) Manually cage spring in hit-safe unit (para 2-4).

(2) Release air pressure by opening drain valves on both air reservoirs (fig. 4-79).

(3) Tag and disconnect brake hoses from brake chambers and relay valve.

(4) Remove cotter pin and clevis pin from slack adjuster and yoke.

(5) Remove two nuts and washers from fail-safe unit mounting bolts and remove fail-safe unit from bracket.

(6) Install new fail-safe unit to bracket with two washers and nuts. Do not tighten nuts. Position ports on the fail-safe unit to align with brake hoses. Tighten nuts.

(7) Connect hoses to brake chamber,

(8) Install yoke to adjuster with clevis pin and cotter pin. Bend back ends of cotter pin to secure.

(9) Manually release spring in fail-safe unit.

(10) Adjust brakes (para 4-34).

c. *Repair of Fail-Safe Unit.*

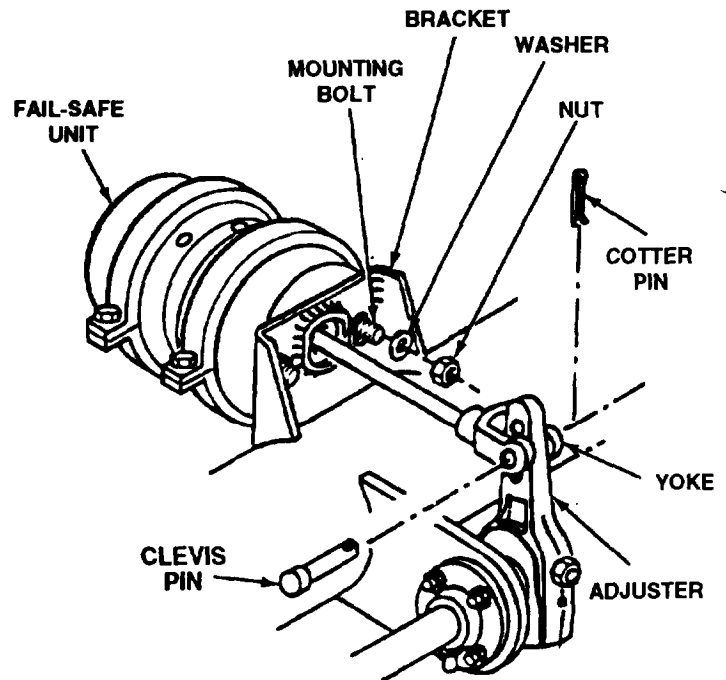

**Figure 4-74. Removing Fail-Safe Air Brake Chamber (M967A1, M969A1, and M970A1 including M970 SN TC-0843, TC-0844, and TC-103 thru TC-178).**

**4-41. Slack Adjuster, M967A1, M969A1, and M970A1 including M970 SN TC-0843, TC-0844, and TC-103 thru TC-178 (Fig. 4-75).**

a. *Removal.*

(1) Remove cotter pin and clevis pin securing yoke to slack adjuster.

(2) Remove retaining ring from end of camshaft.

(3) Using a brass hammer, tap on slack adjuster lightly until it comes off the camshaft.

b. *Inspection and Repair.*

**WARNING**

**DO NOT attempt to repair brake chamber fail-safe unit. It is dangerous because of high spring compression. No repair is authorized for fail-safe unit.**

**WARNING**

**Dry cleaning solvent P-D-680 is toxic and flammable. Always wear protective goggles and gloves, and use only in a well-ventilated area. Avoid contact with skin, eyes, and clothes, and DO NOT breathe vapors. DO NOT use near open flame or excessive heat. The solvent's flash point is 100 °F-138 °F (38°C-59°C). If you become dizzy while using cleaning solvent, immediately get fresh**



air and medical help. If solvent contacts eyes, Immediately wash your eyes with water and get medical aid.

(1) Thoroughly clean slack adjuster, splines of camshaft, and other metal parts using dry cleaning solvent (item 11, Appendix E) and a stiff fiber brush. Make sure parts are completely dry.

(2) Inspect slack adjuster for external damage, and the worm shaft hex head for being frozen or binding.

(3) Replace all parts which are not in good condition.

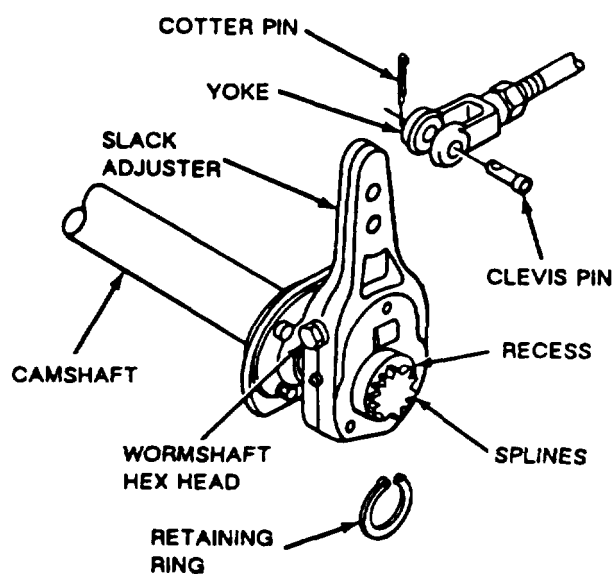

**Figure 4-75. Removing and Installing Slack Adjuster (M967A1, M969A1, and M970A1 including M970 SN TC-0843, TC-0844, and TC-103 thru C-178).**

c. *Installation.*

(1) Place slack adjuster into position on camshaft. Use a brass hammer to lightly tap it into place.

(2) Install retaining ring into recess on camshaft.

(3) Place yoke into position at slack adjuster and install clevis pin.

(4) Install cotter pin to secure clevis pin.

(5) Adjust slack adjuster (para 4-34).

(6) Lubricate slack adjuster (fig. 3-16).

#### 4-42. Brake Camshaft, M967A1, M969A1, and M970A1 including M970 SN TC-0843, TC-0844, and TC-103 thru TC-178 (Fig. 4-76).

a. *Removal.*

(1) Remove wheel and drum assembly (para 4-49).

(2) Remove brake shoes (para 4-34).

(3) Remove slack adjuster (para 4-41).

(4) Expand retaining ring and slide camshaft part way out of spider. Remove retaining ring.

(5) Slide camshaft out of spider.

(6) Remove two washers and two seals from camshaft.

(7) Remove spider bushing.

(8) Remove four nuts, four washers, and four screws securing camshaft bushing assembly to bracket.

(9) Remove inner retainer and outer retainer.

(10) Remove camshaft bushing and two preformed packings.

b. *Inspection and Repair.*

#### **WARNING**

- Dry cleaning solvent P-D-680 is toxic and flammable. Always wear protective goggles and gloves, and use only in a well-ventilated area. Avoid contact with skin, eyes, and clothes, and DO NOT breathe vapors. DO NOT use near open flame or excessive heat. The solvent's flash point is 100°F-138°F (38°C-59°C). If you become dizzy while using cleaning solvent, Immediately get fresh air and medical help. If solvent contacts eyes, Immediately wash your eyes with water and get medical aid.
- Compressed air used for drying or cleaning purposes must not exceed 30 psi (207 kPa). Wear protective clothing (goggles and gloves) and use caution to avoid injury to personnel.

#### **NOTE**

Use a wire brush to clean camshaft and inner and outer retainers, if required, to remove caked-on dirt and corrosion.

(1) Thoroughly clean all metal parts with dry cleaning solvent (item 11, Appendix E). Dry the parts with low pressure compressed air.

- (2) Inspect camshaft for twists and bends.
- (3) Inspect inner and outer retainers for bends and cracks.
- (4) Inspect spider bushing and camshaft bushing for cracks and excessive wear.
- (5) Replace all parts which are not in good condition.

c. *Installation.*

- (1) Assemble camshaft bushing, two preformed packings, and inner and outer retainers to bracket in order shown.
- (2) Install four screws, four washes, and four nuts to secure camshaft bushing assembly to the bracket. Tighten four nuts.
- (3) Install spider bushing.

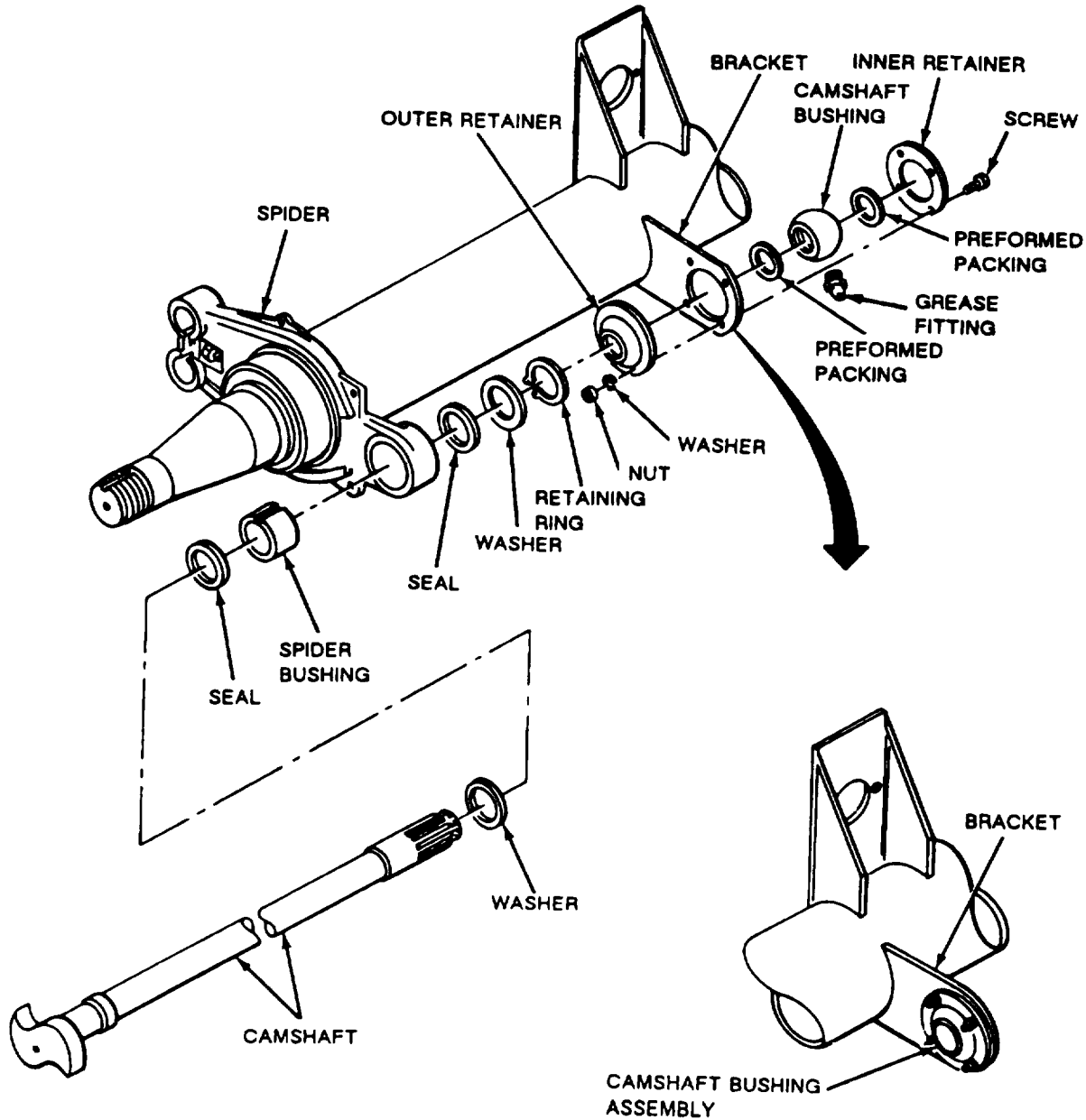

TA502353

Figure 4-76. Brake Camshaft Removal and Installation (M967A1, M969A1, and M970A1 including M970 SN TC-0843, TC-0844, and TC-103 thru TC-178).

(4) Install seal and washer, slide camshaft part way through spider, and install second seal and washer on camshaft in order shown.

(5) Expand retaining ring and slide over camshaft. Install camshaft and lock in place with retaining ring.

(6) Install slack adjuster (para 4-41).

(7) Install brake shoes (para 4-34).

(8) Install wheels and drum assembly (para 4-49).

(9) Adjust slack adjuster (para 4-34).

(10) Lubricate camshaft (fig. 3-18).

#### 4-43. Service and Emergency Couplings, Air Lines and Fittings

##### a. Test.

(1) Connect air brake hose couplings from towing vehicle to semitrailer (fig. 2-1). Apply brakes and coat hose couplings, connectors, and fittings of emergency and service lines with soap and water solution. No leakage is permissible.

(2) Check air lines and fittings for restrictions caused by dents or kinks.

(3) Coupling damage is usually caused by worn, damaged, or improperly installed packing ring. Install new packing ring to stop leaks (para 4-43).

##### b. Packing Ring Replacement (Fig. 4-77).

(1) Remove packing ring by prying out of coupling with screwdriver or other suitable tool.

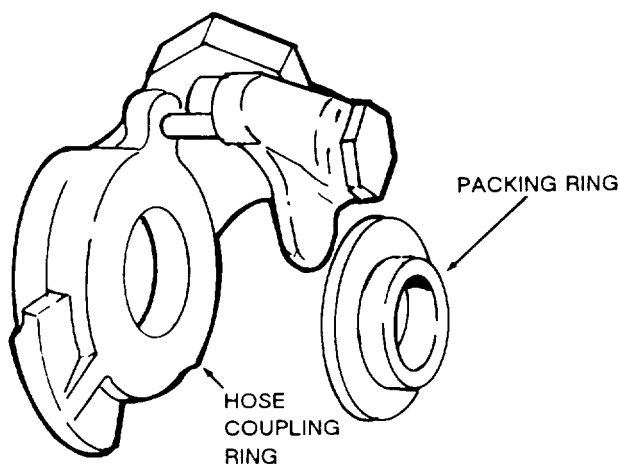

TA099822

Figure 4-77. Packing Ring Installation.

(2) Clean groove in body. Partially collapse packing ring with fingers and put one side of packing ring flange into groove. Use a blunt-ended tool to push ring in place. The packing ring must lie flat with no twists or bulges.

##### c. Repair.

(1) Tighten screws holding air line clips.

(2) Tighten fittings if leaks are found. Replace lines or fittings if leaks cannot be stopped (para 4-48).

#### 4-44. Emergency Relay Valve (Fig. 4-78)

##### a. Test.

(1) When the brake pedal or trailer hand brake lever of the towing vehicle is depressed or applied, air is delivered through the service line to the emergency relay valve.

(2) The emergency relay valve releases air from the primary brake reservoir to the brake chambers to set the brakes.

(3) Engage the service brake and apply soapy water to exhaust port on top of the emergency relay valve. If there is leakage, replace the relay valve.

(4) Apply and release the service brake several times. Listen for immediate response from the relay valve. If there is hesitation in brake application and release, replace the relay valve.

##### b. Replacement.

(1) Block semitrailer wheels to prevent movement.

(2) Disconnect towing vehicle and/or air brake lines and open air drain valves on bottom of both air reservoirs (fig. 4-79). Leave open while replacing valve.

(3) Tag air lines for identification at assembly. Disconnect hose and tube fittings from valve. Remove double check valve and unscrew valve from nipple in reservoir.

(4) Screw new valve onto nipple. Install double check valve, and reconnect hose and tube fittings.

(5) Close air drain valves in both reservoirs. Connect towing vehicle and fill the reservoir.

(6) Test service brakes and parking brakes (para 4-44).

(7) Remove blocking from semitrailer wheels.

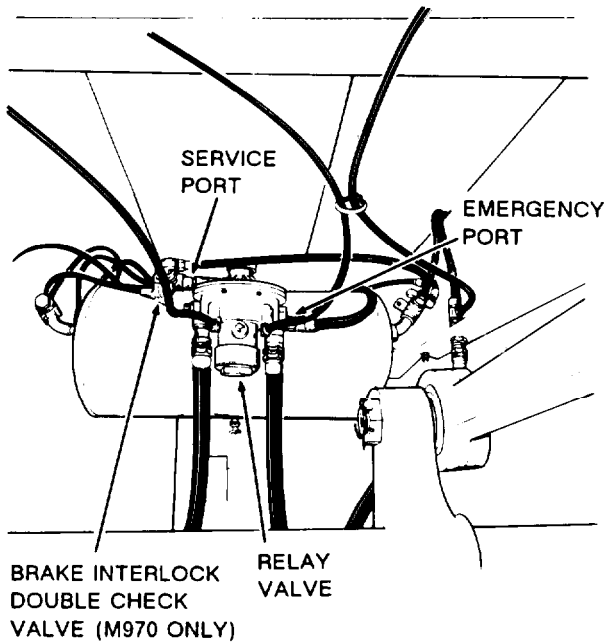

TA099823

**Figure 4-78. Emergency Relay Valve Installation**  
(M970 installation shown - Typical of M967, M967A1, M969, and M969A1 semitrailers, except for brake interlock connection on M970 and M970A1).

**4-45. Air Reservoirs (Fig. 4-79)**

*a. Removal.*

- (1) Block semitrailer wheels to prevent movement.
- (2) Drain air from reservoir by opening air drain valves on bottom of both air reservoirs.
- (3) If air drain valves are to be replaced, unscrew and replace with new ones.
- (4) If rear reservoir is to be replaced, disconnect hoses and fittings to emergency relay valve. Relay is mounted to a nipple on rear reservoir.
- (5) Remove air fittings on each end of reservoir. Remove two mounting bolts on each end of reservoir and remove reservoir. If rear reservoir is removed, emergency relay valve will be removed with it. Remove relay valve by unscrewing from nipple.

*b. Installation.*

- (1) Install new reservoir, bolt in place and reconnect fittings. If rear reservoir was replaced, screw emergency relay valve onto reservoir nipple before replacing reservoir on frame. Close air drain valves. Refill with air and check reservoir for leaks.

- (2) Check fittings, valve, and air drain valves for leaks. Tighten if leaks are found.
- (3) Remove blocks from semitrailer wheels.

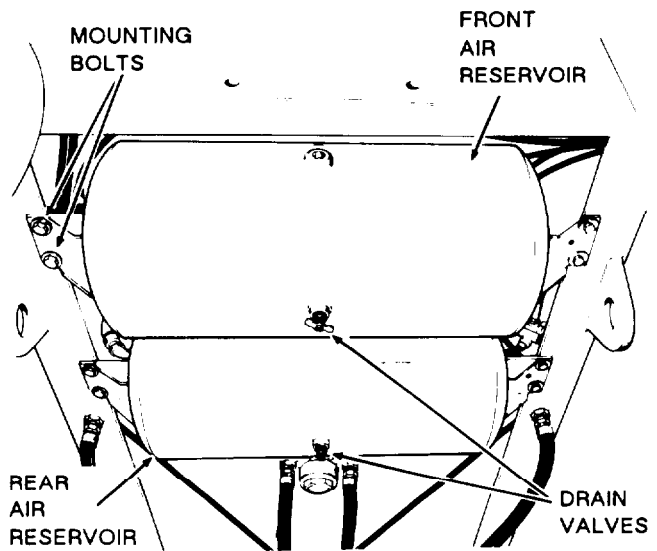
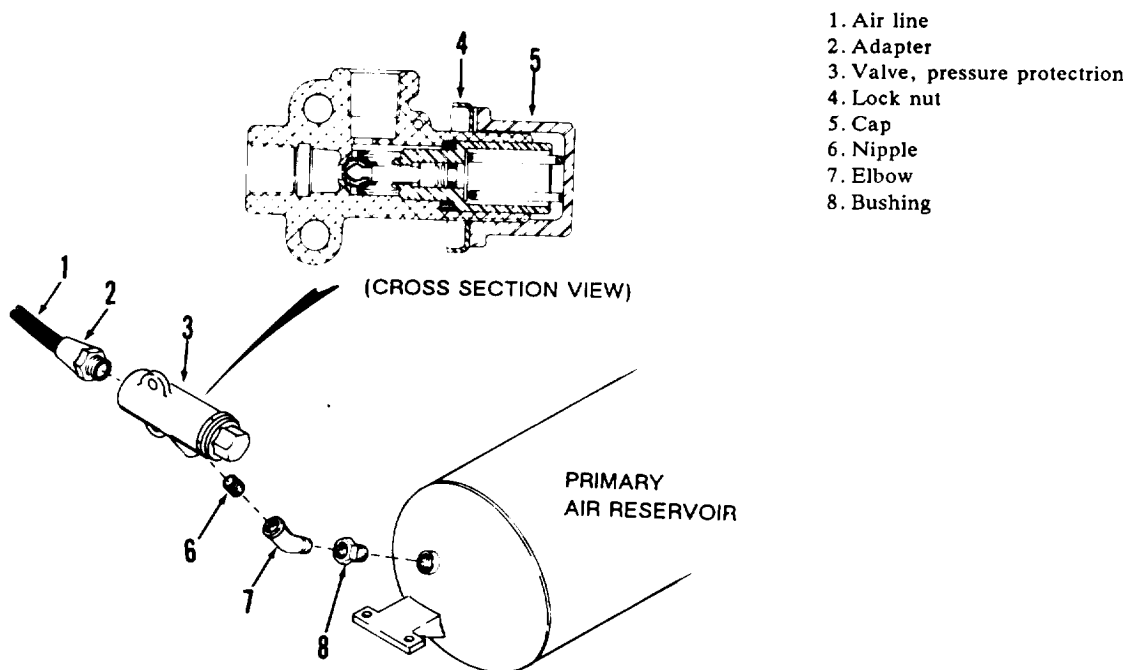

**Figure 4-79. Air Reservoirs.**

**4-46. Pressure Protection Valve (Fig. 4-80)**

*a. Test and Adjustment.*

- (1) Attach air system test gage (table 4-1) to trailer "Emergency" gladhand with gage closest to trailer.
- (2) Attach air supply line to valve end of test gage. Air supply can be either a tractor or stationary source.
- (3) Pressurize system. Close valve on test gage when system is full. Note gage reading. Drain secondary (forward) air reservoir by opening drain valve on bottom of reservoir. When all air has exhausted from secondary system, gage should read 75 psi. If pressure is not correct, adjust pressure protection valve as follows:
  - (a) Loosen locknut (4) at base of cap.
  - (b) Turn cap (5) clockwise to increase pressure setting.
  - (c) Turn cap counterclockwise to decrease setting.
- (4) Repeat step (3) until desired pressure is obtained, then tighten lock nut.
- (5) Remove air system test gage.



1. Air line
2. Adapter
3. Valve, pressure protection
4. Lock nut
5. Cap
6. Nipple
7. Elbow
8. Bushing

Figure 4-80. Pressure Protection Valve.

TA099825

*b. Removal.*

(1) Block semitrailer wheels to prevent movement.

(2) Exhaust air from system by opening drain valves on bottom of air reservoirs.

(3) Remove air line (1, fig. 4-80) and adapter (2) from end of valve.

(4) Unscrew valve (3) from nipple (6).

(5) Remove elbow (7) and bushing (8) from air reservoir if replacement is necessary.

*c. Repair.* No repair is authorized for the pressure protection valve. Replace valve if malfunction occurs.

*d. Installation.*

(1) Apply antiseize tape (item 28, Appendix E) to male threads and install new nipple (6) in side port of valve. Turn valve and nipple into elbow (7) on air reservoir.

(2) Install air line (1) and adapter (2) on valve.

(3) Test and adjust valve (step *a*).

(4) Remove blocking from semitrailer wheels.

#### 4-47. Parking Brake Control Valve (Fig. 4-81)

*a. General.* The parking brake control valve is basically an off-on, push-pull control valve. Its function is to release the fail-safe (spring) brakes for semitrailer movement by other than a towing vehicle.

(1) The valve can only be used when all air has been exhausted from the rear (primary) reservoir.

(2) In the OUT position, the valve is closed, allowing springs in the fail-safe chambers to apply braking pressure.

(3) In the IN position, air is delivered from the front (secondary) reservoir to the fail-safe chamber, compressing the spring, and releasing the brakes.

(4) When the trailer is connected to a towing vehicle, air from the emergency line is applied to the pilot port of the valve, maintaining the OUT position. However, air from the emergency line is also directly applied to the fail-safe chamber compressing the spring during normal towing operation.

*b. Test.* Internal leakage in the valve is indicated if the spring brakes do not apply when the button is pulled out and the system is at full pressure. External leakage can be detected by applying soapy water around the valve stem. No leakage is permitted. If the valve leaks or does not operate, replace valve.

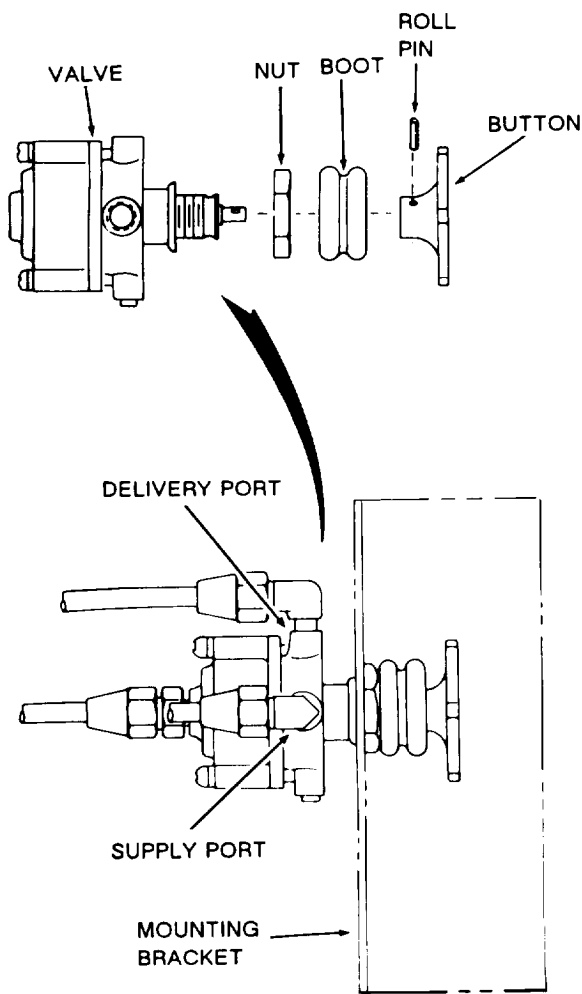

TA099821

**Figure 4-81. Parking Brake Control Valve Installation.**

*c. Removal.*

- (1) Block semitrailer wheels to prevent movement.
- (2) Exhaust air from system by opening drain valves on bottom of air reservoirs.
- (3) Tag and disconnect airlines from elbows and adapter on control valve.
- (4) With a small drift and hammer, remove roll pin which secures button to stem of control valve. Remove button.
- (5) Remove nut on neck of valve and pull the control valve from the mounting bracket.

(6) Remove fittings from valve ports.

*d. Repair.* No repair is authorized for the parking brake control valve. If malfunction or leakage is indicated, replace the complete valve.

*e. Installation.*

(1) Install fittings on valve ports. Use antiseize tape (item 28, Appendix E) on male pipe threads. Remove button and nut from control valve so that valve can be inserted into mounting bracket.

(2) Position control valve in mounting bracket. Install nut on neck of control valve and tighten securely.

(3) Install button on end of valve stem. Align hole in button with hole in stem and install roll pin.

(4) Connect air lines to fittings on valve ports and remove tags.

(5) Remove blocking from semitrailer wheels.

**4-48. Air Lines, Valves, and Fittings (Figs. 4-82 and 4-83)**

*a. General.* The general arrangement of the air brake system on the semitrailers is shown in figures 4-82 and 4-83. Nylon tubing connects the gladhands on front of semitrailer to the brake relay valve on rear air reservoir. Clips fasten the tubing to the underside of the tank and to the frame members. Grommets are installed to protect the tubing where it passes through the frame and cross members. Hoses and tubing connect the brake chambers to the reservoirs and relay valve.

*b. Maintenance.* Visually inspect for damage to air lines, loose clips, or missing grommets. Also check the following:

(1) Brake hoses should be looped in a way that prevents the hoses from hanging below the axle.

(2) Separators on brake hoses should be positioned to prevent brake hoses from rubbing against axles or other brake hoses.

(3) Clips should be bent down securely on tubing.

*c. Replacement of Nylon Tubing.*

(1) Block semitrailer wheels to prevent movement.

(2) Exhaust air from system by opening drain valves on bottom of air reservoirs.

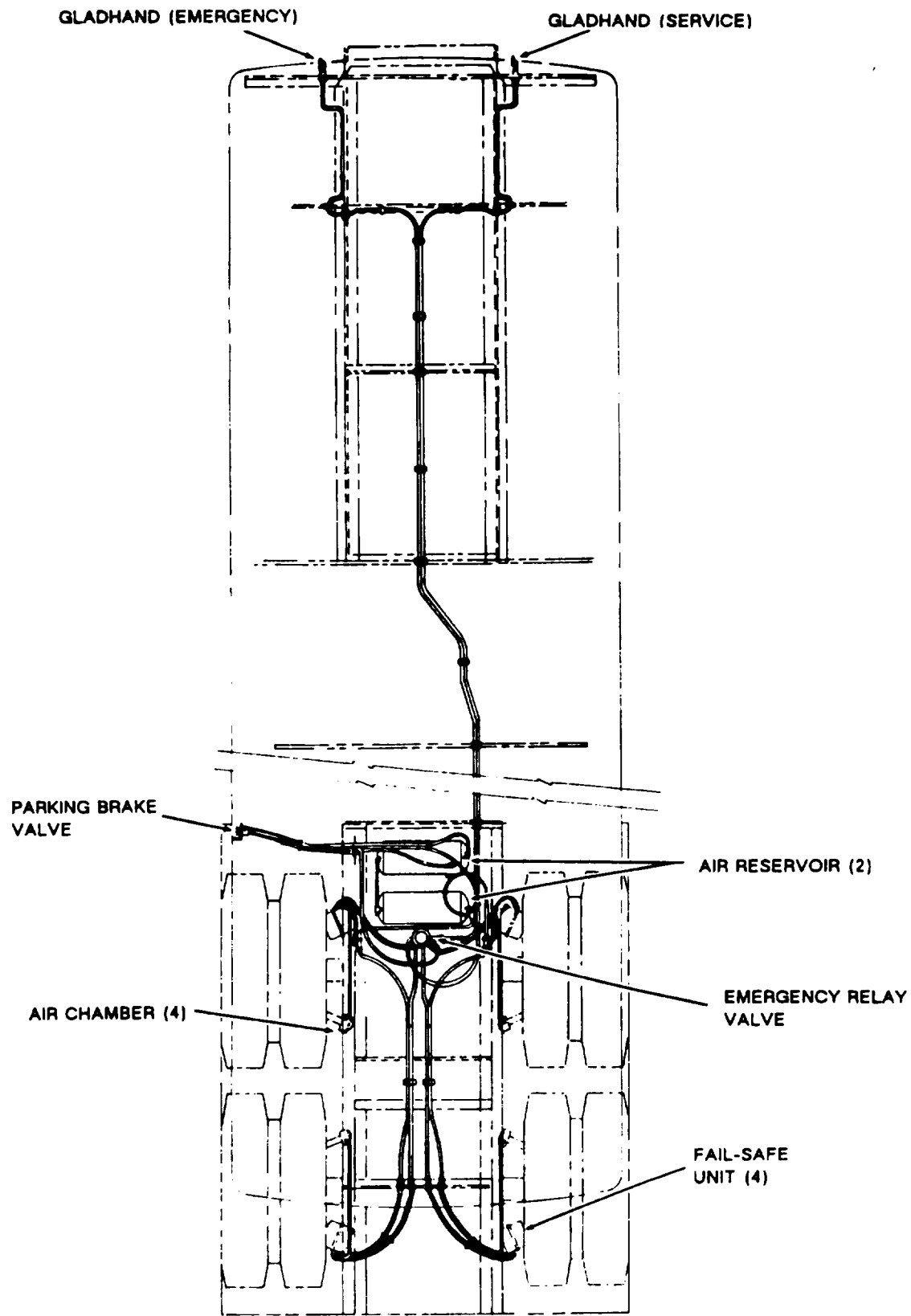

TA099827

Figure 4-82. Air Brake System (M967, M969, and M970 except M970 SN TC-0843, TC-0844, and TC-103 thru TC-178).

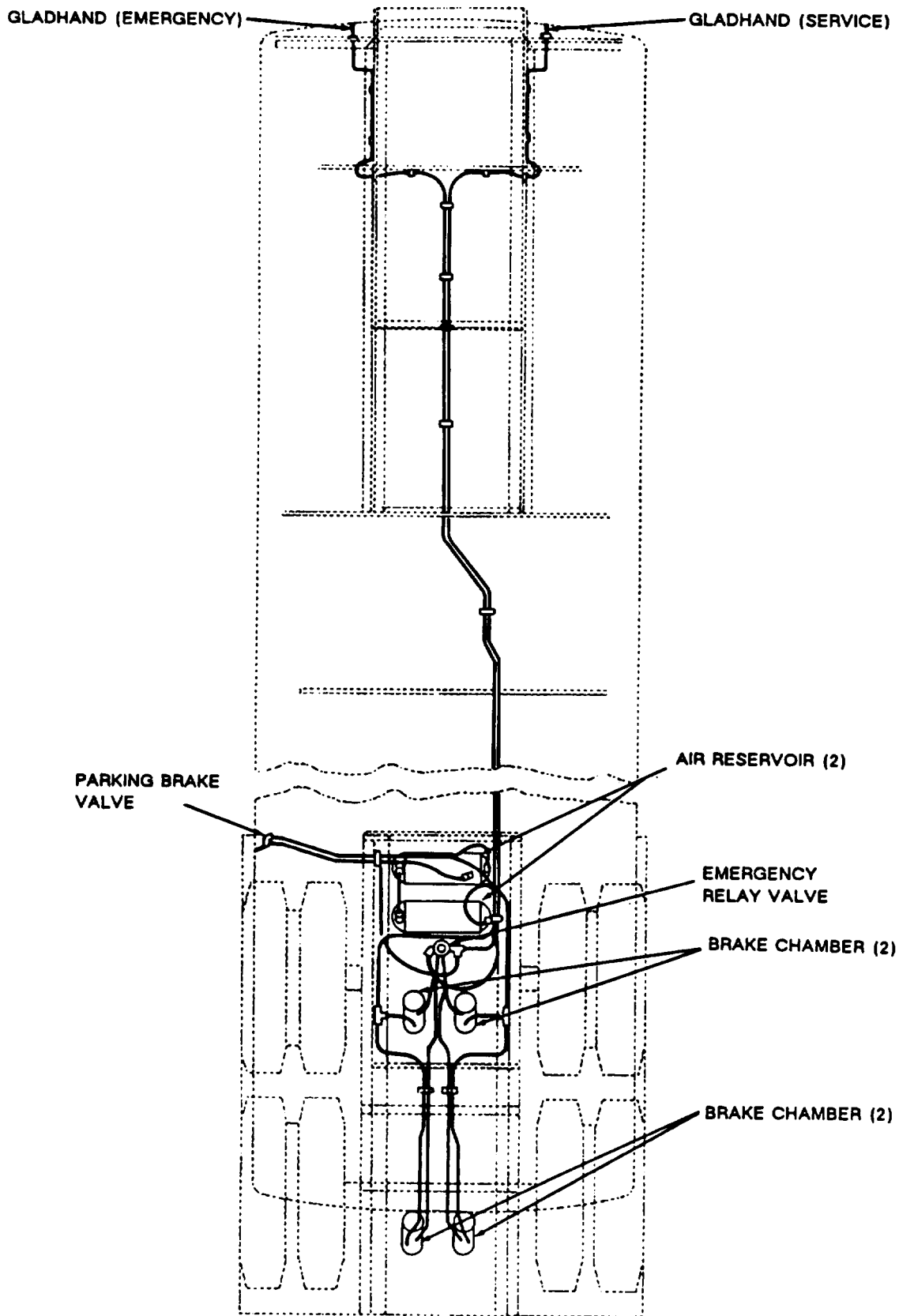

TA502354

Figure 4-83. Air Brake System (M967A1, M969A1, and M970A1 including M970 SN TC-0843, TC-0844, and TC-103 thru TC-178).



(3) Disconnect tubing from fitting and remove the insert, compression sleeve and nut on both ends of tubing. Release the clips and pull tubing through grommets.

**NOTE**

**Tubing is stocked in bulk lengths. Measure original tubing and cut new tubing to same length.**

(4) Install tubing on semitrailer and bend clips down securely to hold tubing in position.

(5) Trim ends of tubing to get a smooth, square cut. Slide tubing nut on end of tube. Slide impression sleeve over end of tubing. Install tubing insert. Connect tubing to adapter fitting and tighten tubing nut securely. Do the same procedure on both ends.

(6) Check replaced tubing for leaks. No leaks are permitted.

(7) Remove blocking from semitrailer wheels.

*d. Air Line Fittings.* Use antiseize tape (item 28, Appendix E) on all male pipe threads. Take care not to let any of the tape get into the system.

**Section XIII. MAINTENANCE OF WHEELS, HUBS, AND DRUMS**

**4-49. Wheels, Hubs, and Drums**

**WARNING**

**Spare tire weighs 190 pounds. Four-person lift, or suitable lifting device, is required.**

*a Tire and Wheel Replacement (Fig. 4-84).*

(1) *Removal.* Block any of the tires that are not being removed. Jack up axle until tire is clear of ground. Support axle with jack stand or blocking. Remove outer stud nuts (fig. 4-84). Remove tire and wheel assembly. If inner tire must be removed, remove the ten inner stud nuts (fig. 4-84), and remove inner tire and wheel assembly.

(2) *Repair.*

(a) Repair tubes (para 4-50).

(b) Refer to general support maintenance for repair of tires.

(3) *Installation.* Position inner wheel over studs on axle hub. Replace ten inner stud nuts (fig. 4-84), lower tire to ground, and tighten to 450-500 lb.-ft. using sequence in figure 4-85. Jack up axle and position outer wheel over inner stud nuts (fig. 4-84). Lower tire to ground, and using sequence in figure 4-85, tighten nuts to 450-500 lb.-ft.

*b. Removal of Tires, Wheels, Hub, and Drum as an Assembly (M967, M969, and M970 except M970 SN TC-0844, TC-0844, and TC-103 thru TC-178) (Fig. 4-86).*

**WARNING**

**The fail-safe chamber power spring must be manually compressed and the air reservoirs must be vented of pressure before removal of hub and drum assembly.**

(1) Block any of the tires that are not being removed.

(2) Manually compress fail-safe chamber power spring (para 2-4).

(3) Release air pressure by opening drain valves on both air reservoirs (fig. 4-79).

(4) Jack up axle until tires are clear of ground. Support axle with jack stand or blocking.

(5) Remove ten screws and lockwashers (fig. 4-86) securing hub cap to hub. Remove hub cap and hub cap gasket. Discard gasket.

(6) Remove outer wheel bearing nut (fig. 4-86), leek ring, and inner wheel bearing nut.

(7) Remove outer wheel bearing cone.

**NOTE**

If wheel lift jack is not available follow steps (8) through (10).

(8) Apply grease (item 17, Appendix E) to a 45x20-inch 10 gage steel plate (table 4-1), laying a grease track approximately 10-inches wide the length of the plate.

(9) Place the grease plate, with greased side up, under the tires. Lower tires so that they are just resting on the grease plate, with the majority of the vehicle weight still on the jack.

**NOTE**

It may be necessary to back the automatic adjusters out to allow brake shoes to clear ridge on brake drum (para 4-33).

(10) Lower tires, wheels, hub, and brake drum off of axle spindle.

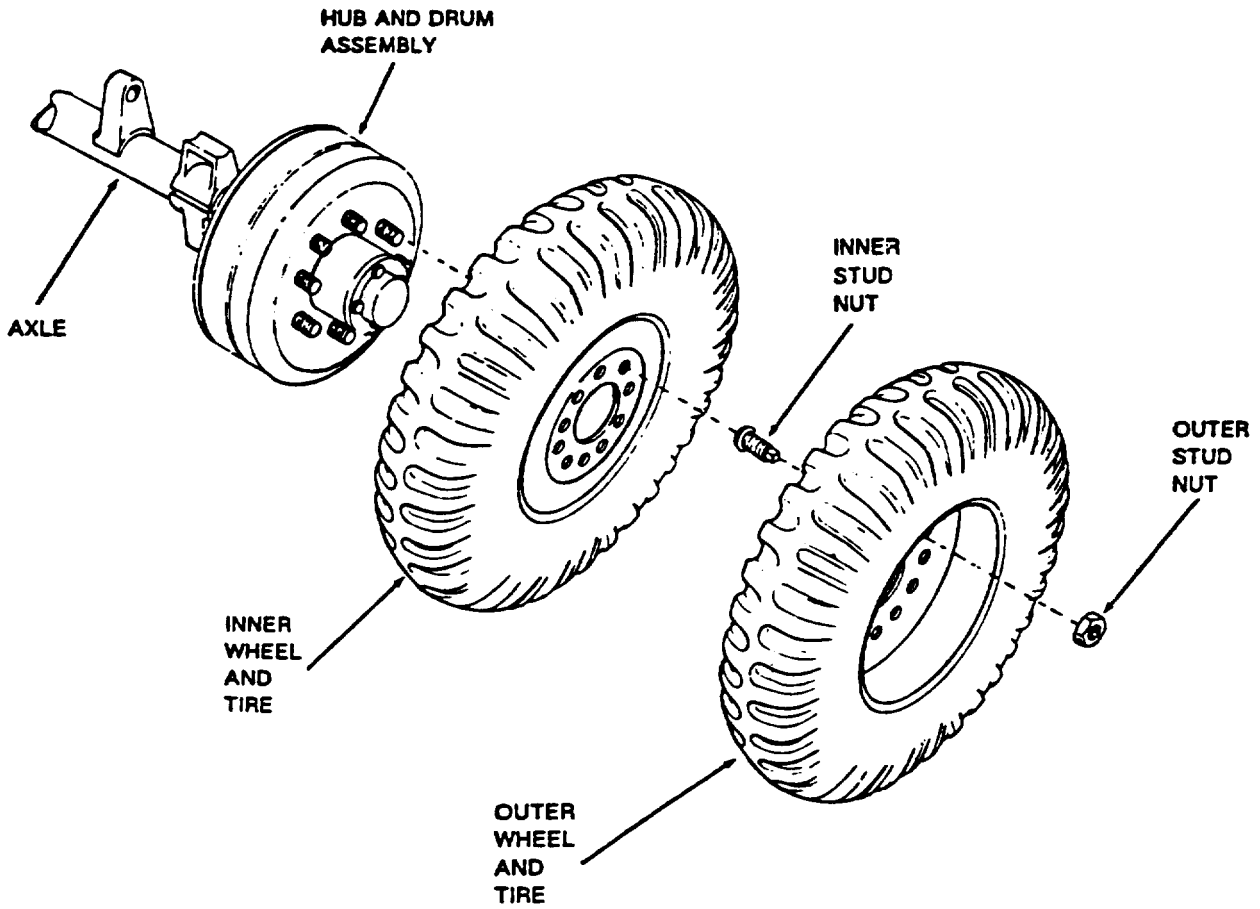

TA099828

Figure 4-84. Replacement of Tires and Wheels.

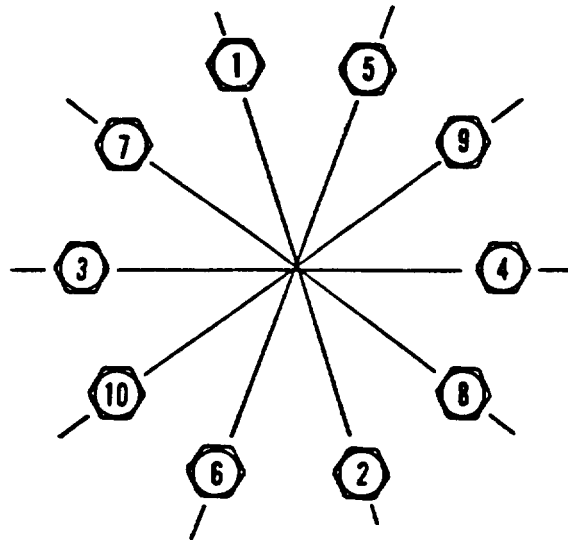

TA099829

Figure 4-85. Tightening Order for Wheel Stud Nuts.

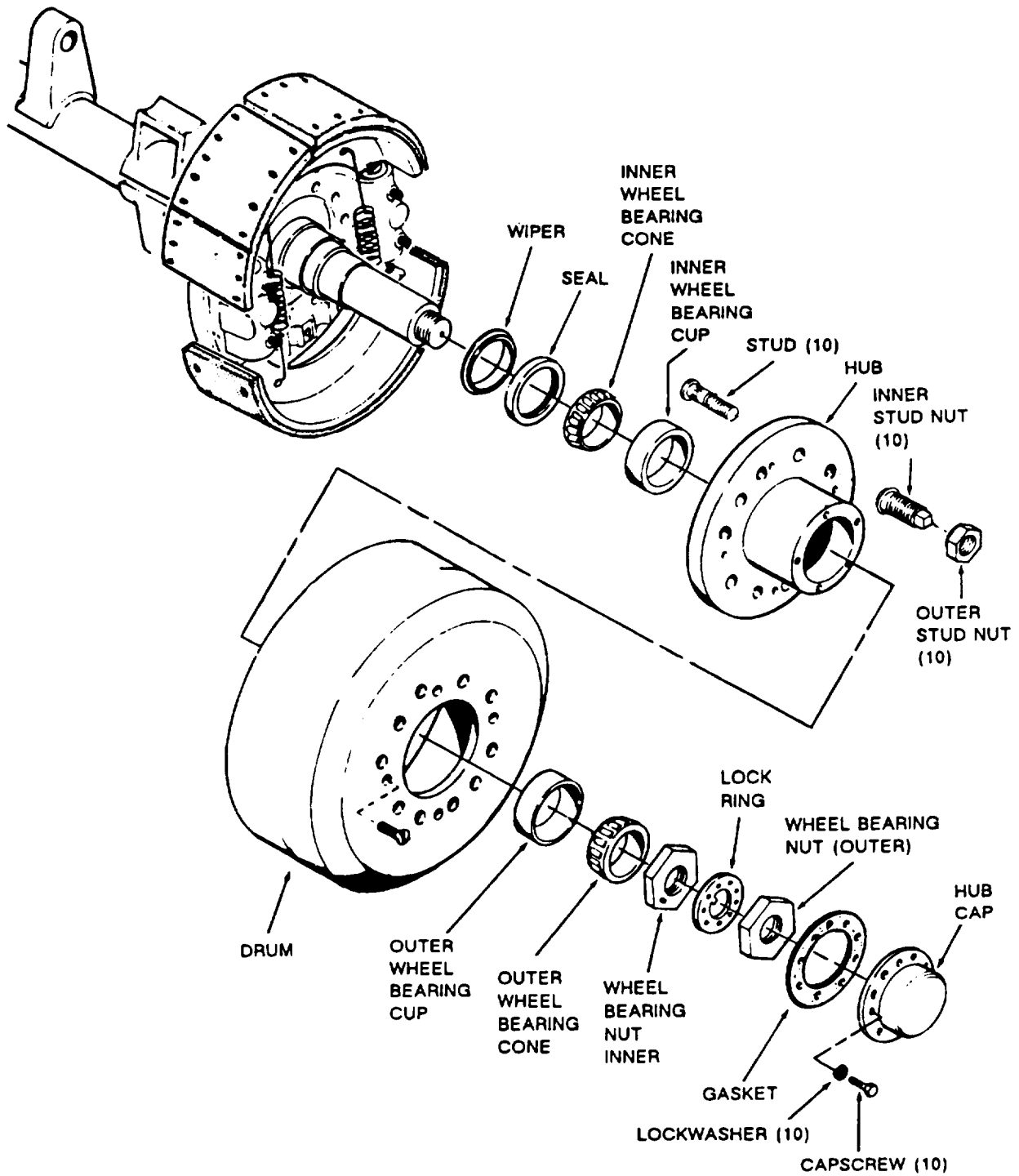

TA099830

Figure 4-86. Hub, Drum, and Wheel Bearings (M967, M969, and M970 except M970 SN TC-0843, TC-0844, and TC-103 thru TC-178).

c. *Replacement of Wheel Bearings (M967, M969, and M970 except M970 SN TC-0843, TC-0844, and TC-103 thru TC-178) (Fig. 4-86).*

(1) Removal.

(a) Remove tires, wheels hub and drum as an assembly (b above).

(b) Remove wiper (fig. 4-86) from either the hub or the axle spindle.

**NOTE**

**If no seal puller is available, drive bearing cone and seal out using a brass drift and hammer from the outer side of the hub.**

(c) Remove inner seal with a seal puller and then remove inner wheel bearing cone.

(2) *Inspection and Repair.*

**WARNING**

- **Dry cleaning solvent P-D-680 Is toxic and flammable. Always wear protective goggles and gloves, and use only In a well-ventilated area. Avoid contact with skin, eyes, and clothes, and DO NOT breathe vapors. DO NOT use near open flame or excessive heat. The solvent's flash point is 100°F-138°F (38°C-59°C). If you become dizzy while using cleaning solvent, immediately get fresh air and medical help. If solvent contacts eyes, immediately wash your eyes with water and get medical aid.**
- **Compressed air used for drying or cleaning purposes must not exceed 30 psi (207 kPa). Wear protective clothing (goggles and gloves) and use caution to avoid injury to personnel.**

**CAUTION**

- **Do not clean parts with gasoline, In a hot solution tank, or with water and alkaline solutions. Separate wheels and hub before cleaning. Dry cleaning solvent will deteriorate the tires.**
- **Do not spin bearings with compressed air.**

(u) Thoroughly clean all parts with dry cleaning solvent (item 11, Appendix E) and a stiff fiber brush. Ensure that parts are completely dry. Use low pressure compressed air to dry parts, if available.

**NOTE**

**If wheel bearings need replacing, bearing cups must also be replaced (Step (d)).**

(b) Inspect wheel bearings for cracks or breaks in bearing cage, etching or pitting on roller surfaces, and any evidence of wear. Replace if worn or damaged.

(c) Pack bearings from large end of cone with grease (item 17, Appendix E), ensuring that ail cavities between rollers and cage are filled. Cover bearings with a clean, lint-free rag until time to install.

(d) Inspect bearing cups in hub for pits, grooves, or flaking. If damaged, use a puller to remove. Drive in new bearing cups with a suitable driver.

(e) Inspect hub cap for damage to flange that would allow water to leak into wheel bearings. Replace if damaged.

(f) Replace hub cap gasket.

(g) Check threads of studs, screws, and nuts for damage.

(h) Inspect brake drum for pitting or scoring. Inspect hub bearing surface for damage. If brake drum is damaged, notify direct support maintenance for repair.

(3) *Installation (Figs. 4-86 and 4-87).*

(a) Ensure that the axle spindle is thoroughly clean.

(b) Install inner seal and wiper using seal replacer.

(c) With tire, wheel, hub, and brake drum assembly in upright position, install inner wheel bearing.

(d) Install tire, wheel, hub, and brake drum assembly (d below).

d. *Installation and Adjustment of Tires, Wheels, Hub, and Drum as an Assembly (M967, M969, and M970 except M970 SN TC-0843, TC-0844, and TC-103 thru TC-178).*

**NOTE**

**Jack may be adjusted to compensate for hub/spindle misalignment when installing hub to spindle.**

(1) Position hub and drum assembly on spindle with tires resting on greased plate. If drum binds on brake shoes when partially installed, turn both adjusting bolt starwheels to reduce brake shoe spread (para 4-33). Push hubs fully onto spindle.

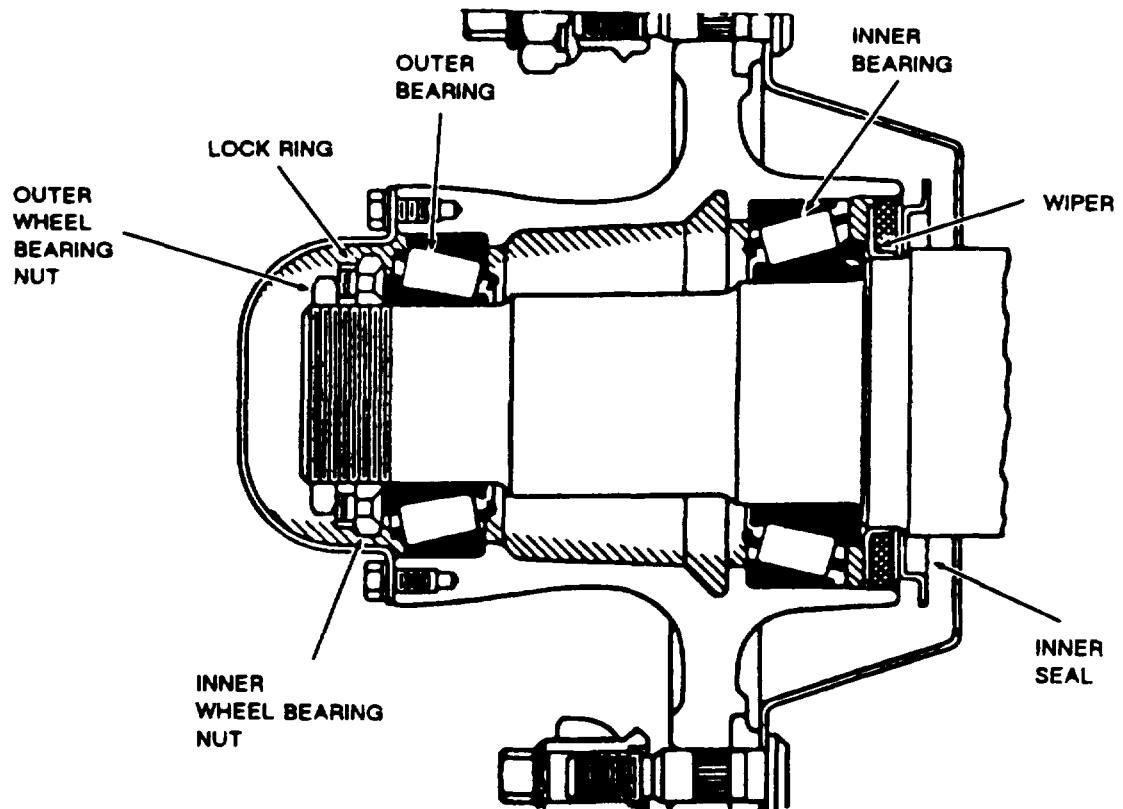

TA099831

**Figure 4-87. Wheel Bearing Installation (M967, M969, and M970 except M970 SN TC-0843, TC-0844, and TC-103 thru TC-178).**

- (2) Install outer bearing cone by inserting into bearing cup. Install inner wheel bearing nut against outer bearing. Provide for sufficient clearance between brake shoe and drum so brake drag will not interfere with bearing adjustment.
  - (3) Jack wheel completely off ground.
  - (4) Tighten inner wheel bearing adjusting nut to 200 lb.-ft. while rotating hub and drum assembly in both directions.
  - (5) Back off inner wheel bearing adjusting nut approximately  $\frac{1}{4}$  (2 flats) to  $\frac{1}{3}$  ( $\frac{22}{3}$  flats) turn so dowel on nut will align with hole in lock ring (fig. 4-86) when tab on lock ring is positioned on axle spindle keyway. Install and tighten outer wheel bearing jam nut to 250-300 lb.-ft.
  - (6) Apply light coat of grease (item 17, Appendix E) to new hub cap gasket and position gasket on hub.
  - (7) Install hub cap and secure with ten capscrews and lockwashers. Tighten screws to 16-20 lb.-ft.
  - (8) Pressurize air system by attaching towing vehicle air lines to semitrailer and starting towing vehicle engine.
  - (9) Adjust brakes (para 4-33).
  - (10) Manually release fail-safe chamber power spring (para 2-4).
  - (11) Remove any blocking from tires.
- e. Removal of Tires, Wheels, Hub, and Drum as an Assembly (M967A1, M969A1, and M970A1 including M970 SN TC-0843, TC-0844, and TC-103 thru TC-178) (Fig 4-88).*
- (1) Block any of the tires that are not being removed.

**WARNING**

**The fall-safe chamber power spring must be manually compressed and the air reservoirs must be vented of pressure before removal of hub and drum assembly.**

(2) Manually compress fail-safe chamber power spring (para 2-4).

(3) Release air pressure by opening drain valves on both air reservoirs (fig. 4-79).

(4) Jack up axle until tires are clear of ground. Support axle with jack stand or blocking.

(5) Remove six bolts and lockwashers (fig. 4-88) securing hub cap to hub. Remove hub cap and hub cap gasket. Discard gasket.

(6) Remove outer wheel bearing nut (fig. 4-88), wheel bearing washer, lock ring, and inner wheel bearing nut.

(7) Remove outer wheel bearing cone.

**NOTE**

**If wheel lift jack is not available, follow steps (8) through (10).**

(8) Apply *grease* (item 17, Appendix E) to a 45x 20-inch 10 gage steel plate (table 4-1), laying a grease track approximately 10-inches wide the length of the plate.

(9) Place the grease plate, with greased side up, under the tires. Lower tires so that they are just resting on the grease plate, with the majority of the vehicle weight still on the jack.

(10) Slide tires, wheels, hub, and brake drum off of axle spindle.

*f. Replacement of Wheel Bearings (M967A1, M969A1, and M970A1 including M970 SN TC-0843, TC-0844, and TC-103 thru TC-178) (Fig. 4-88).*

(1) *Removal.*

(a) Remove tires, wheels, hub, and drum as an assembly (e above).

**NOTE**

**If no seal puller is available, drive bearing cone and seal out using a brass drift and hammer from the outer side of the hub.**

(b) Remove seal (fig. 4-88) with a seal puller and remove inner wheel bearing cone.

(2) *Inspection and Repair.*

**WARNING**

- **Dry cleaning solvent P-D-680 is toxic and flammable. Always wear protective goggles and gloves, and use only in a well-ventilated area. Avoid contact with skin, eyes, and clothes, and DO NOT breathe vapors. DO NOT use near open flame or excessive heat. The solvent's flash point is 100°F-138°F (38°C-59°C). If you become dizzy while using cleaning solvent, immediately get fresh air and medical help. If solvent contacts eyes, immediately wash your eyes with water and get medical aid.**
- **Compressed air used for drying or cleaning purposes must not exceed 30 psi (207 kPa). Wear protective clothing (goggles and gloves) and use caution to avoid injury to personnel.**

**CAUTION**

- **Do not clean parts with gasoline, in a hot solution tank, or with water end alkaline solutions. Separate wheels and hub before cleaning. Dry cleaning solvent will deteriorate the tires.**
- **Do not spin bearings with compressed air.**

(a) Thoroughly clean all parts with dry cleaning solvent (item 11, Appendix E) and a stiff fiber brush. Ensure that parts are completely dry. Use low pressure compressed air to dry parts, if available.

**NOTE**

**If wheel bearings need replacing, bearing cups must also be replaced (Step (d)).**

(b) Inspect wheel bearings for cracks or breaks in bearing cage, etching or pitting on roller surfaces, and any evidence of wear. Replace if worn or damaged.

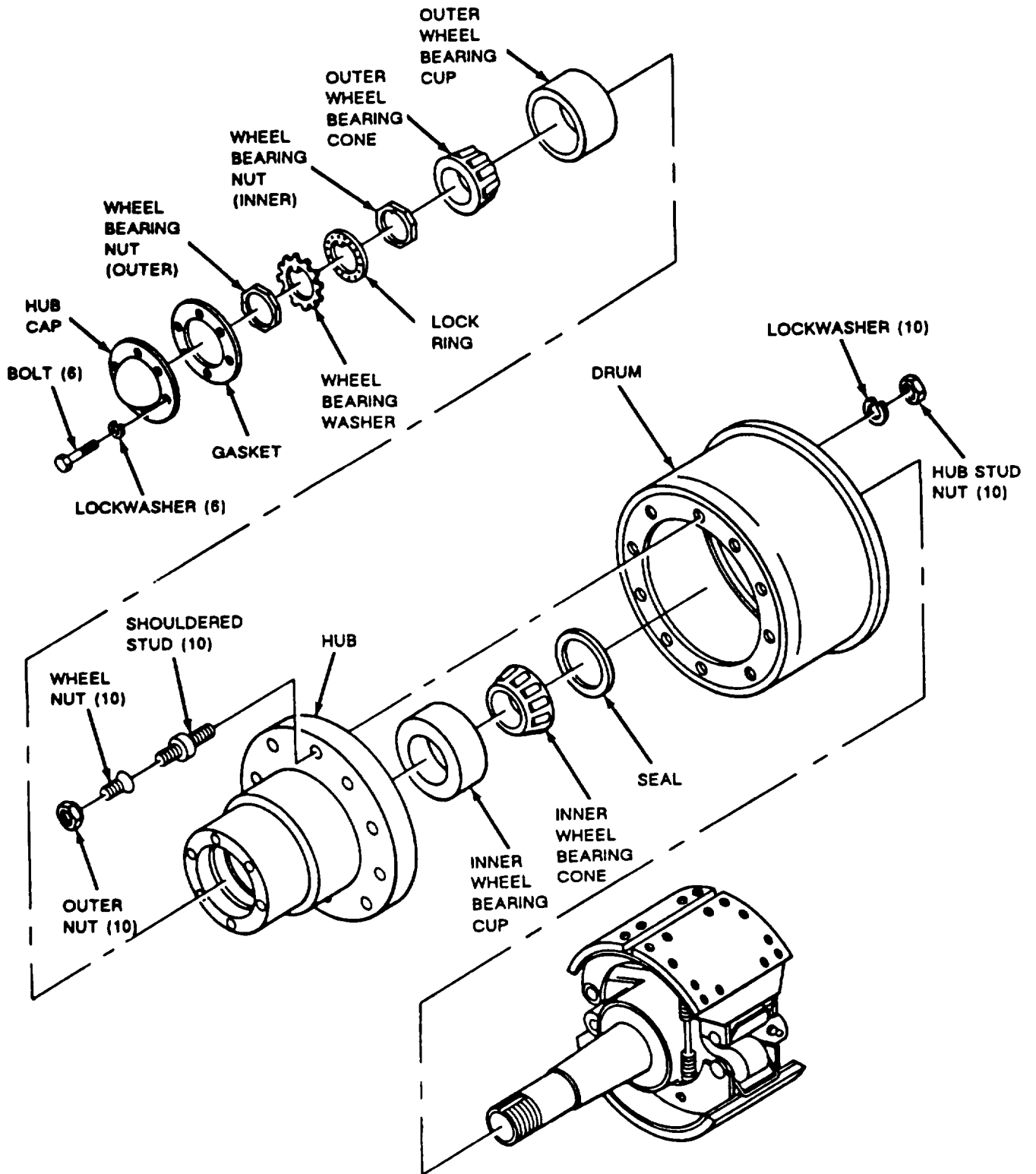

TA223025

Figure 4-88. Hub, Drum, and Wheel Bearings (M967A1, M969A1, and M970A1 including M970 SN TC-0843, TC-0844, and TC-103 thru TC-178).

(c) Pack bearings from large end of cone with grease (item 17, Appendix E), ensuring that all cavities between rollers and cage are filled. Cover bearings with a clean, lint-free rag until time to install.

(d) Inspect bearing cups in hub for pits, grooves, or flaking. If damaged, use a puller to remove. Drive in new bearing with a suitable driver.

(e) Inspect hub cap for damage to flange that would allow water to leak into wheel bearings. Replace if damaged.

(f) Replace hub cap gasket.

(g) Check threads of studs, screws, and nuts for damage.

(h) Inspect brake drum for pitting or scoring. Inspect hub bearing surface for damage. If brake drum is damaged, notify direct support maintenance for repair.

(3) Installation (Figs. 4-88 and 4-89).

(a) Ensure that the axle spindle is thoroughly clean.

(b) With tire, wheel, hub, and brake drum assembly in upright position, install inner wheel bearing.

(c) Install inner seal using seal replacer.

(d) Install tire, wheel, hub, and brake drum assembly (step g).

g. *Installation and Adjustment of Tires, Wheels, Hubs, and Drum as an Assembly (M967A1, M969A1, and M970A1 including M970 SN TC-0843, TC-0844, and TC-103 thru TC-178).*

**NOTE**

**Jack may be adjusted to compensate for hub/spindle misalignment when installing hub to spindle.**

(1) Position hub and drum assembly on spindle with tires resting on greased plate. If drum binds on brake shoes when partially installed, adjust brake shoes to reduce brakeshoe spread (para 4-34). Push hubs fully onto spindle.

(2) Jack wheel completely off ground.

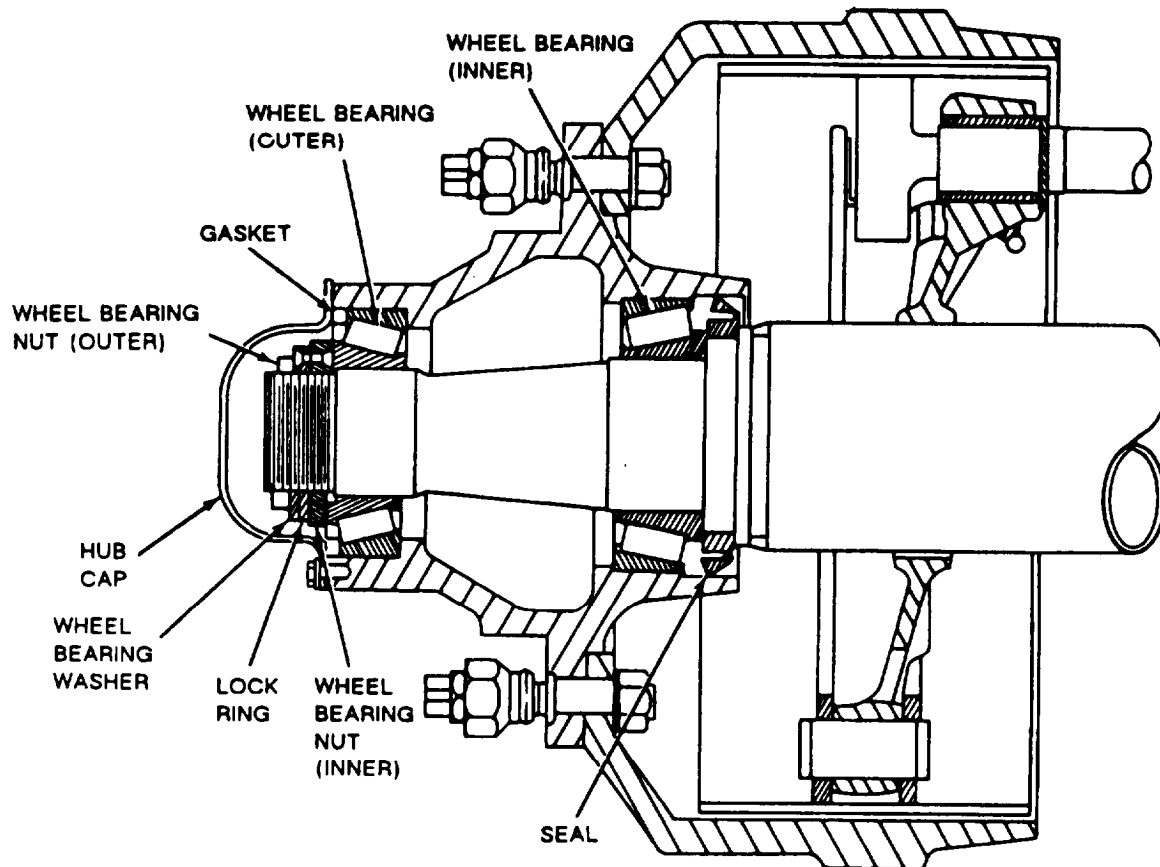

TA221213

Figure 4-89. Wheel Bearing Installation (M967A1, M969A1, and M970A1 including M970 SN TC-0843, TC-0844, and TC-103 thru TC-178).



(3) Tighten inner adjustment nut to minimum of 75 ft-lb to ensure proper seating of e bearings and cup in wheel hub.

(4) Loosen inner adjustment nut so wheel will turn freely.

(5) Retighten inner adjustment nut to 50 ft-lb while rotating wheel, in order to properly position bearings for final adjustment.

(6) Loosen inner adjustment nut 1/3 turn.

**WARNING**

**Failure to back off the inner adjustment nut could cause brake and axle spindle overheating or damage, which could result in the wheel locking up or coming off during vehicle operation, resulting in property damage or loss of life.**

(7) Install spindle nut lockwasher so that dowel on inner nut aligns with hole in lockwasher and washer tang fits in spindle keyway.

**WARNING**

**Failure to torque outer locknut properly could cause wheel to come off during vehicle operation, which could result in property damage or loss of life.**

If an external tan or setscrew-type lockwasher is used, it is important to remember to bend tabs over outer locknut, or to install the setscrew in lockwasher, after the outer nut has been properly torqued.

(8) Install outer locknut and tighten to 250-400 ft-lb.

(9) Apply a light coat of grease (Item 17, Appendix E) to new hub cap gasket and position gasket on hub.

(10) Install hub cap and secure with six bolts and lockwashers. Tighten bolts to 16-20 ft.-lb.

(11) Pressurize air system by attaching towing vehicle air lines to semitrailer and starting towing vehicle engine.

(12) Adjust brakes (para 4-34).

(13) Manually release fail-safe chamber power spring (para 2-4).

(14) Remove any blocking from tires.

*h. Wheel Studs (M967, M969, and M970 except M970 SN TC-0843, TC-0844, and TC-103 thru TC-178).*

(1) *Removal (Fig. 4-86).*

(a) Remove tire and wheel.

(b) Remove five screws that fasten brake drum to hub and remove brake drum.

(c) Remove ten capscrews that fasten hub cap to hub. Remove hub cap and gasket.

(d) Using wheel bearing nut wrench, remove outer wheel bearing nut, lock ring, and inner wheel bearing nut.

(e) Remove outer wheel bearing cone.

(f) Remove hub from axle spindle being careful not to damage wiper and seal.

(g) Drive broken wheel studs from hub.

(2) *Installation (Fig. 4-86).*

(a) Install wheel studs into hub. Use a hammer and driver to install studs.

(b) If wiper remained with axle spindle when hub was removed, remove wiper and install in hub. Install outer wheel bearing cone in hub.

(c) Pack bearings from large end of cone with grease (item 17, Appendix E) making sure all cavities between rollers and cup are filled.

(d) Install hub onto axle spindle. Install inner wheel bearing nut, lock ring, and outer wheel bearing nut, but do not tighten.

(e) Install brake drum over the hub and secure with five screws.

(f) Install wheels and adjust wheel bearings.

*i. Wheel Studs (M967A1, M969A1, and M970A1 including M970 SN TC-0843, TC-0844, and TC-103 thru TC-178).*

(1) *Removal (Fig. 4-88).*

(a) Remove wheels and tires.

(b) Remove six bolts and lockwashers that fasten the hub cap to the hub. Remove hubcap and gasket.

(c) Using wheel bearing nut wrench remove outer wheel bearing nut, wheel bearing washer, lock ring, and inner wheel bearing nut.

(d) Remove outer wheel bearing cone.

(e) Remove hub and drum from axle spindle being careful not to damage seal.

(f) Remove nuts, lockwashers, and broken studs from hub and drum.

(2) *Installation (Fig. 4-88).*

(a) Install studs (short side from shoulder facing out) into hub and drum and secure studs with lockwashers and nuts.

(b) Install hub and drum onto axle spindle.

(c) Pack bearing from large end of cone with grease (item 17, Appendix E) making sure all cavities between rollers and cup are filled.

(d) Install outer wheel bearing cone in hub.

(e) Install inner bearing nut, lock ring, wheel bearing washer, and outer wheel bearing nut, but do not tighten.

(f) Install wheels and tires and adjust wheel bearings.

**4-50. Tire and Tube**

*a. Service. Gage tires for correct pressure. For hard surface roads, inflate to 60 psi; for cross-country and sand, inflate to 40 psi.*

b. *Inspection.* Remove objects such as nails or glass. Check for apparent loss of air, unusual wear, or missing valve caps. Replace as required.

c. *Repair.* Refer to TM 9-2610-200-24 for instructions on dismantling, repair, and mounting of tire and tube on rim.

#### Section XIV. MAINTENANCE OF FRAME AND TOWING ATTACHMENTS

##### 4-51. Emergency Valve Control and Cable (Fig. 4-90)

a. *Cleaning and Inspection.*

#### **WARNING**

Dry cleaning solvent P-D-680 is toxic and flammable. Always wear protective goggles and gloves, and use only in a well-ventilated area. Avoid contact with skin, eyes, and clothes, and DO NOT breathe vapors. DO NOT use near open flame or excessive heat. The solvent's flash point is 100°F-138°F (38°C-59°C). If you become dizzy while using cleaning solvent, immediately get fresh air and medical help. If solvent contacts eyes, immediately wash your eyes with water and get medical aid.

(1) Clean control handle of valve operator A and connecting parts, cable and emergency valve with dry cleaning solvent (item 11, Appendix E).

(2) Inspect for cracks in control handle, frayed cables, loose U-bolts, loose or bent cable runways, cotter pins, and control mounting bolts.

b. *Service.*

(1) Tighten any loose U-bolt cable connectors, adjusting bolts, and bracket mounting bolts at each end of cable. Adjust if necessary.

(2) Lubricate all linkage.

c. *Adjustment.*

(1) Ensure that control handle of valve operator A is pushed in and that the emergency valve is closed. Pull on handle of the emergency valve shutoff at front curbside of semitrailer to maintain shutoff handle in the open position.

(2) Loosen U-bolt connectors to loosen cable end connections.

(3) Remove all slack in cables, then tighten U-bolt connectors.

(4) Check that emergency valve will open and close when control handle of valve operator A is operated.

(5) Pull on valve operator A to open emergency valve. Check that pulling on the emergency valve shut-off handle will close the emergency valve.

(6) Repeat steps (1) through (5) if cables do not function properly.

d. *Removal.* Tag and disconnect control cables from the emergency valve control. Remove two capscrews and nuts that secure control to side of cabinet. Remove valve control.

e. *Disassembly and Assembly (Fig. 4-90).*

(1) Remove roll pin (8, fig. 4-90) securing shaft (9) to bracket (7).

(2) Remove shaft (9). Remove lever (1) and the trip bar assembly (10).

(3) Remove cotter pin (12) and clevis pin (13) that secures offset link (2) to handle (1). Remove offset link (2).

(4) Disassemble further if needed (fig. 4-90).

(5) Reassemble by reversing steps (1) through (4).

f. *Installation.*

(1) Mount emergency valve control in place using two nuts and capscrews.

(2) Reconnect the cables and adjust (step c).

##### 4-52. Upper Coupler/Kingpin Assembly

a. *Service.*

(1) Remove dust, dirt, and old grease from kingpin.

(2) Grease liberally with clean grease (item 17, Appendix E).

(3) If semitrailer has a bolt-on kingpin, check tightness of bolts holding kingpin to plate (fig. 4-91).

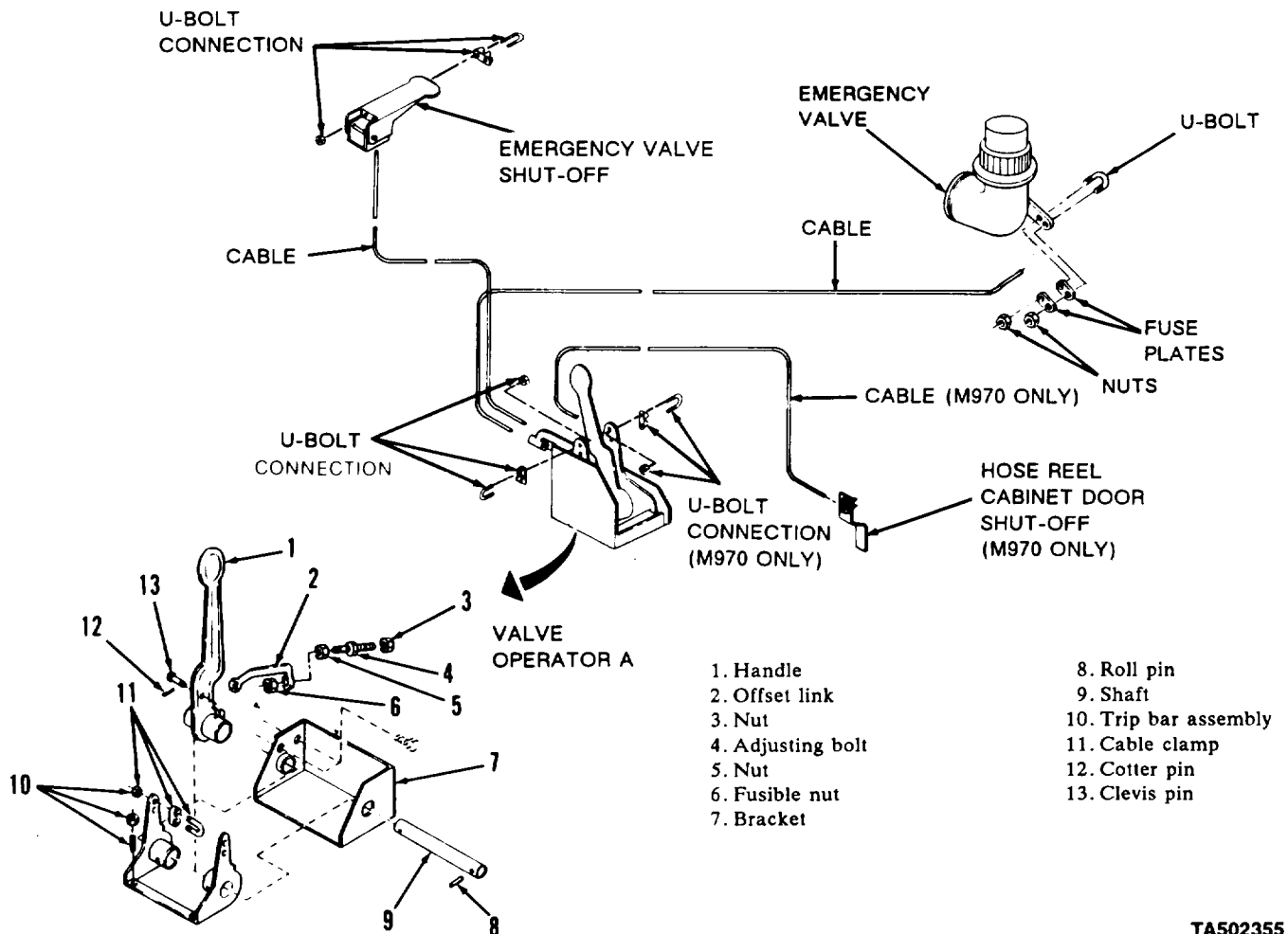

Figure 4-90. Emergency Valve Control and Cable.

TA502355

(4) If semitrailer has a bolt-on upper coupler (kingpin) assembly, check tightness of bolts holding plate to frame. If bolts are loose, tighten them to 140 lb.-ft.

(5) For replacement of bolt-on upper coupler (kingpin) assembly, refer to direct support maintenance. For replacement of bolt-on kingpin, refer to step *b*.

*b. Bolt-on Kingpin Replacement (Early Models) (fig. 4-91).*

(1) Remove eight mounting bolts and remove kingpin.

(2) Coat mating surfaces with corrosion preventive (item 10, Appendix E) (fig. 4-91).

(3) Install kingpin and tighten bolts to 250-275 lb.-ft.

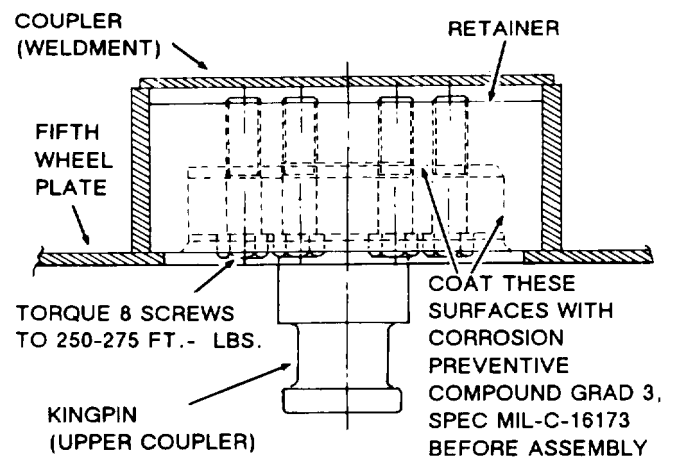

Figure 4-91. Bolt-on Kingpin Installation (Early Models).

TA099833

**4-53. Spare Wheel Carrier (Fig. 4-92)**

**WARNING**

**Dry cleaning solvent P-D-680 is toxic and flammable. Always wear protective goggles and gloves, and use only in a well-ventilated area. Avoid contact with skin, eyes, and clothes, and DO NOT breathe vapors. DO NOT use near open flame or excessive heat. The solvent's flash point is 100°F-138°F (38°C-59°C). If you become dizzy while using cleaning solvent, immediately get fresh air and medical help. If solvent contacts eyes, immediately wash your eyes with water and get medical aid.**

- a. *Service.* Clean with water and stiff brush. Use dry cleaning solvent (item 11, Appendix E) to degrease.
- b. *Replacement.* If bracket needs replacing, notify direct support maintenance.
- c. *Repair.* Repair is limited to straightening bracket.

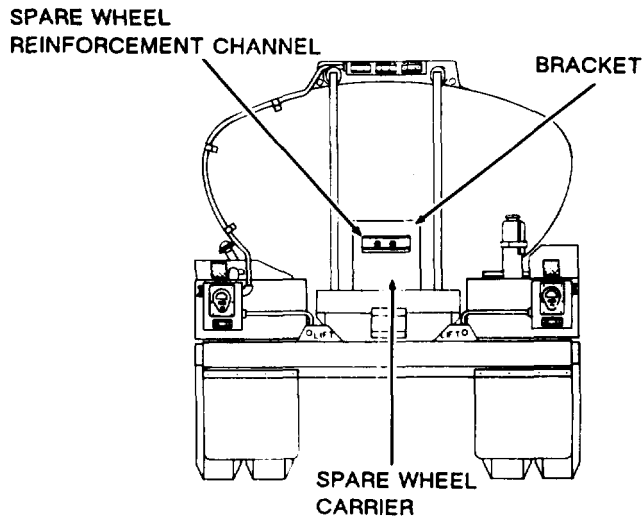

TA502356

**Figure 4-92. Spare Wheel Carrier**

**4-54. Landing Gear (Fig. 4-93)**

- a. *Removal of Landing Gear Shoe.*

(1) Block wheels to prevent semitrailer movement. Lift front end of semitrailer with jacks, and block securely.

(2) Remove roll pins and outer washer from lower ends of leg assembly and axle.

(3) Pull axle from shoe to be removed. Remove shoe.

- b. *Installation of Landing Gear Shoe.*

(1) Position shoe at end of landing gear leg assembly. Insert axle through one side of shoe, through inner washer, leg, other inner washer, and through other side of shoe.

(2) Reinsert outer washers and roll pins.

(3) Remove jacks and blocking.

- c. *Removal of Landing Gear Leg Assembly.*

(1) Remove shoe of leg to be removed (para a).

(2) Remove two capscrews, lockwashers, and nuts which attach braces (fig. 4-93) to the leg assembly. Remove capscrew, lockwasher, and nut attaching rod coupling to leg. If rod and brace cannot be moved out of way, loosen nuts on ends of brace attached to semitrailer frame.

(3) If leg with gear box is to be removed, remove capserew, washer, and nut that attaches coupling to leg. Remove four mounting capscrews, washers, and nuts, and remove gearbox assembly and coupling.

(4) Remove eight capscrews, washers, and nuts securing leg to semitrailer frame. Remove leg.

- d. *Installation of Landing Gear Leg Assembly.*

(1) Position leg assembly onto semitrailer frame. Attach with eight capscrews, washers, and nuts.

(2) Position gearbox assembly and coupling on landing gear leg. Install two mounting capscrews, washers and nuts.

(3) Fasten coupling to operating shaft with capscrew, washer, and nut.

(4) Attach brace to leg assembly with capscrew, lockwasher, and nut.

**NOTE**

**Ensure that legs are extended equally before holes are alined and screw inserted in rod coupling.**

(5) Attach rod coupling to leg assembly with a capscrew, lockwasher, and nut.

(6) Install shoe on leg assembly (para b).

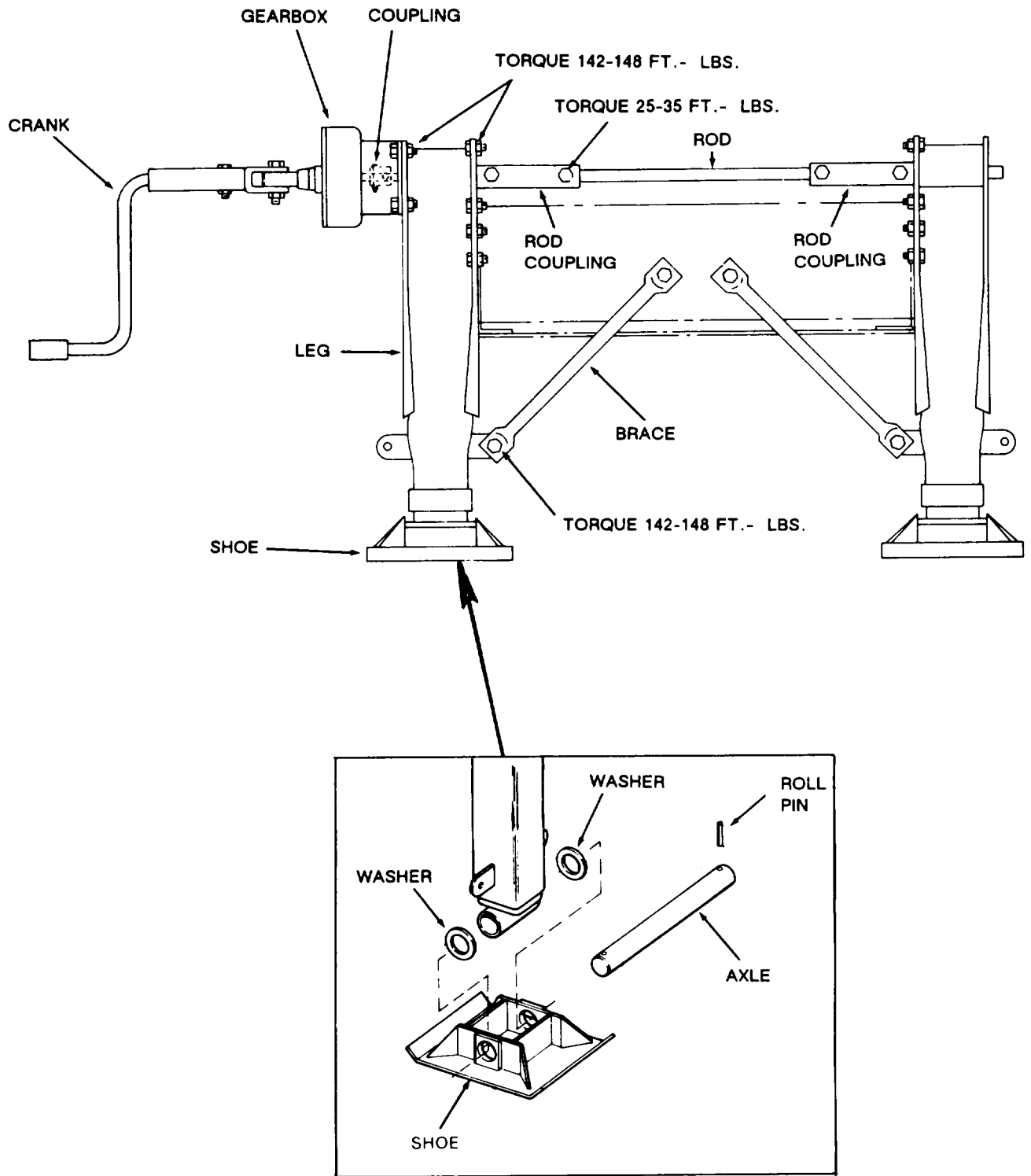

Figure 4-93. Landing Gear Installation.

TA099835

**4-55. Board Assembly, Landing Gear (Fig. 4-94)**

a. Replace board assembly by removing two screws, washers, nuts, handle, and removing chain from handle. Attach chain to handle and secure handle to board assembly with two screws, washers, and nuts.

b. Replace chain assembly by removing chain from bracket and board handle. Attach chain to bracket and handle.

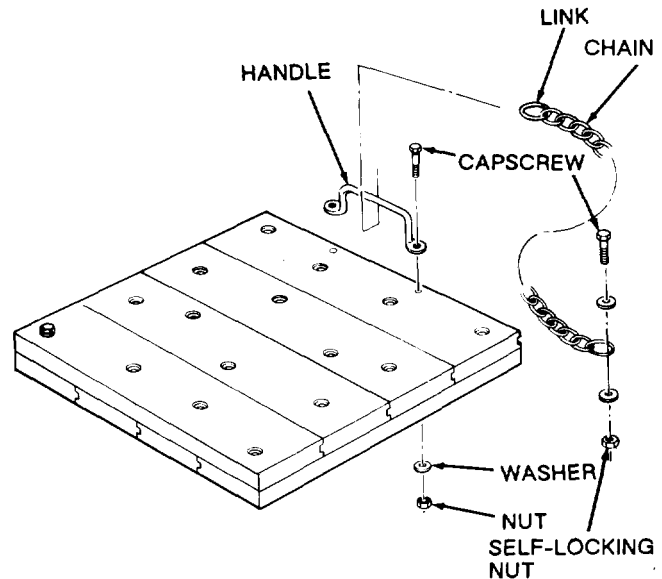

**Figure 4-94. Ground Board Assembly,**

**Section XV. MAINTENANCE OF TANK BODY PARTS**

**4-56. Brackets, Splash Plates, and Mudflaps (Figs. 4-95 and 4-96)**

a. *Removal.*

(1) Remove three bolts and nuts holding front splash plate to frame.

(2) Remove four bolts, washers, and nuts from bracket holding mudflaps to rear bumper.

b. *Installation.*

(1) Position front splash plate and fasten to frame with three bolts and nuts.

(2) New mudflaps are stocked in one size only. Cut and drill the mudflaps using the dimensions shown in figure 4-98.

(3) Put mudflaps in position, place bracket on top side of mudflaps, and fasten to rear bumper with four capscrews, washers, and nuts.

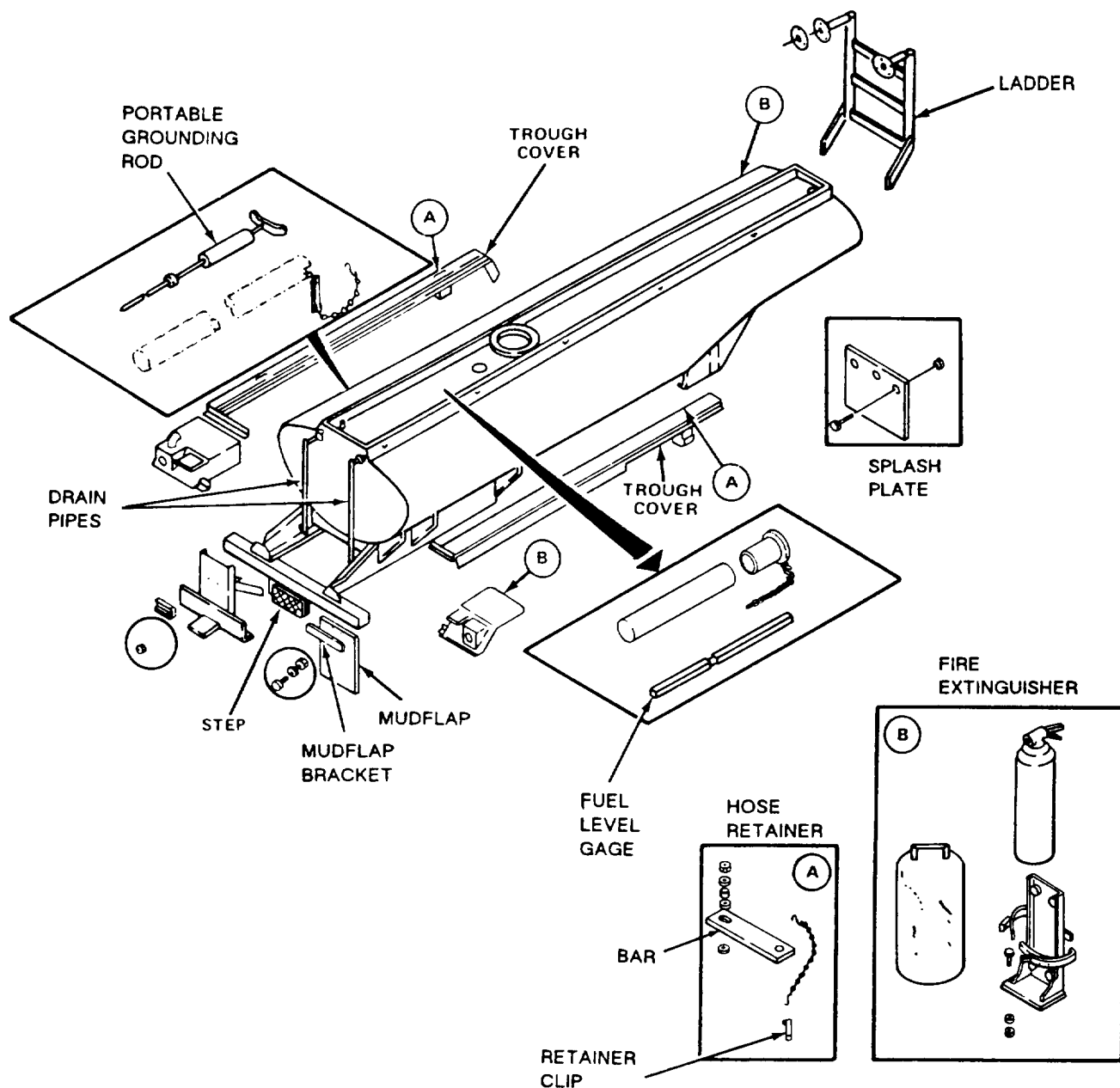
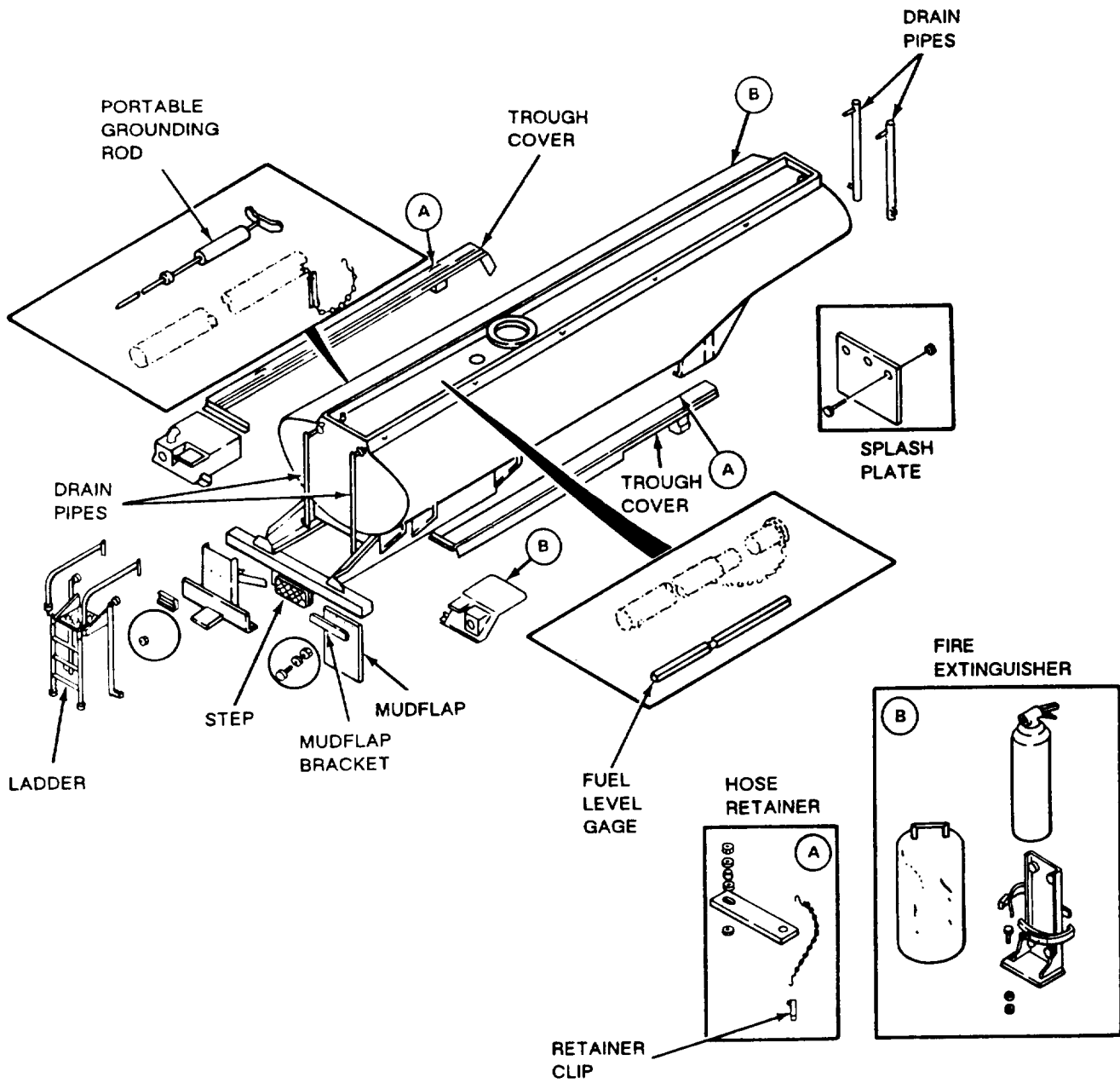

Figure 4-95. Tank Body Parts (M967, M969, and M970).

TA502358



TA221214

Figure 4-96. Tank Body Parts (M967A1, M969A1, and M970A1).

4-57. Miscellaneous Body Parts (Fig. 4-97)

**WARNING**

Ladder has narrow tread. Use care when climbing.

a. Vent Caps.

(1) If fuel leakage is evident at vent cap, remove vent cap and gasket. Discard gasket.

(2) Apply antiseize tape (item 28, Appendix E) to threads of pipe nipple.

(3) Install new gasket inside vent cap.



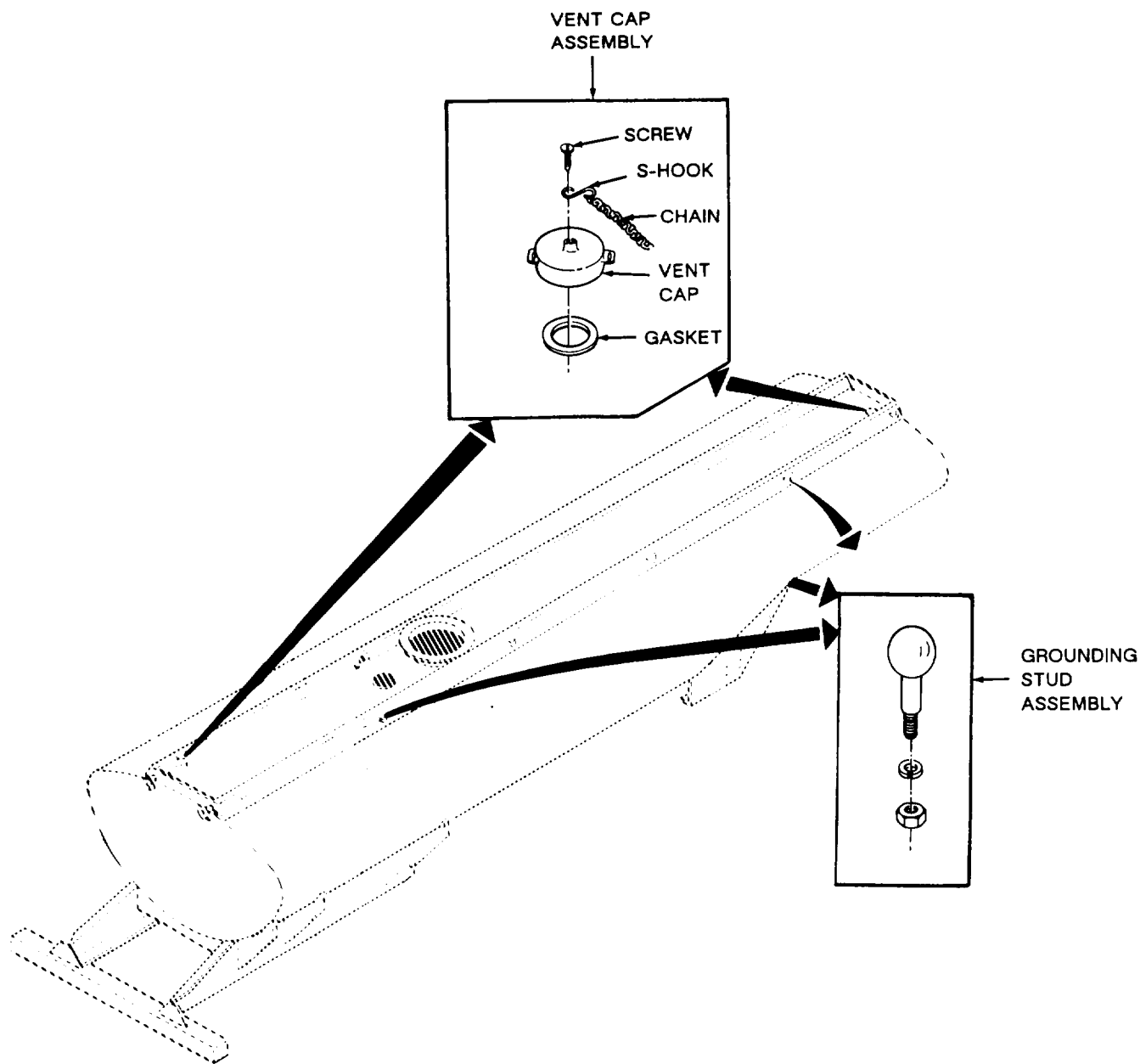

TA502359

**Figure 4-97. Vent Caps and Grounding Studs.**

(4) Install vent cap and tighten securely using a pipe wrench.

*b. Grounding Studs.*

**NOTE**

**For location of all grounding studs, refer to figures 1-1 through 1-11.**

(1) Ensure that grounding studs are installed to clean, unpainted metal surfaces. If mounting surface is painted, scrape off paint to bare metal.

(2) Tighten grounding stud mounting hardware securely to ensure a good grounding contact.

(3) Check to ensure that International Grounding Symbol  and DO NOT PAINT GND STUD stencils are present and legible.

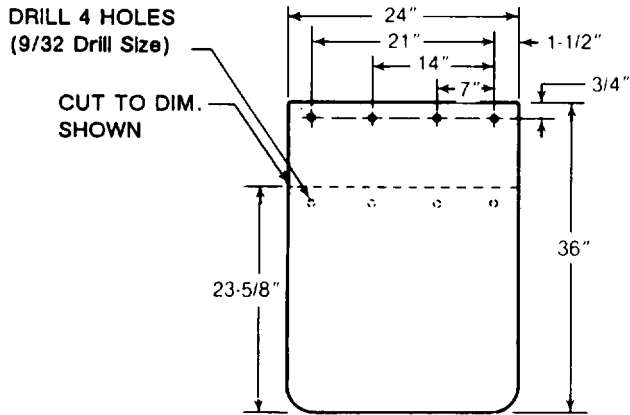

TA099838

Figure 4-98. Mudflap Modification.

4-58. Tool Box (Fig. 4-99)

a. Replacement.

NOTE

On some semitrailers, tool box may be tack welded in position. Break weld with a cold chisel to remove tool box. Do not reweld when installing tool box.

- (1) Remove tool box contents and set aside.
- (2) Place a support under tool box to support it when mounting screws are removed.

(3) Disconnect the emergency valve control (1, fig. 4-99) by removing capscrew (2) and nut (3).

(4) Remove two capscrews (4) and nuts (5).

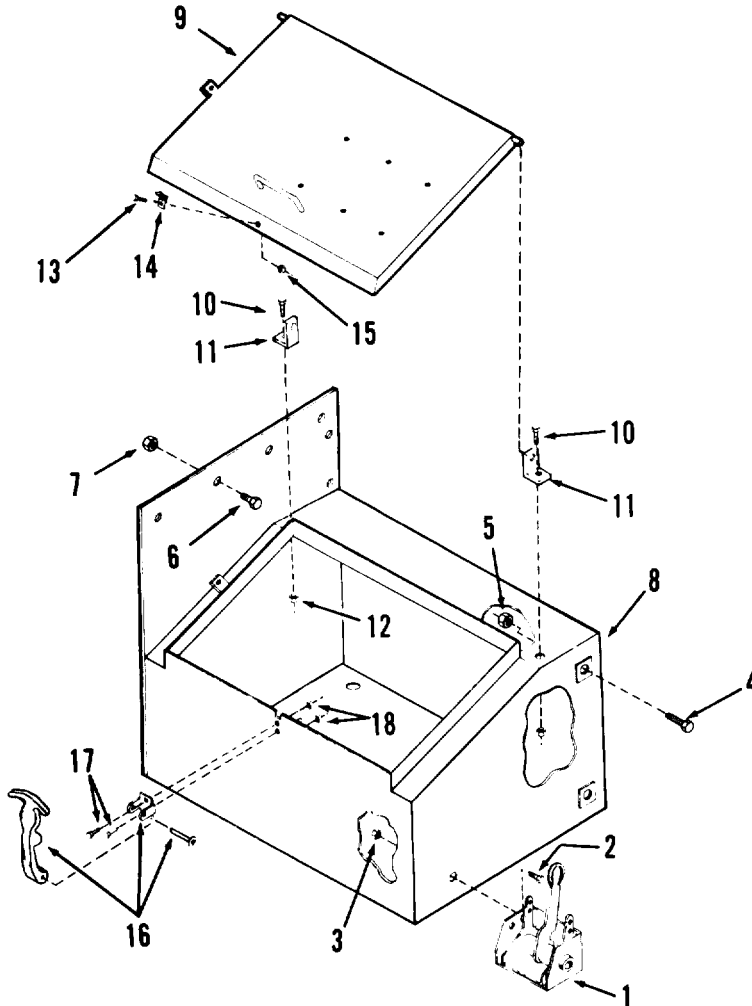

1. Emergency valve control
2. Capscrew
3. Nut
4. Capscrew (2)
5. Nut (2)
6. Capscrew (4)
7. Nut (4)
8. Tool box
9. Cover
10. Capscrew (2)
11. Angle (2)
12. Nut (2)
13. Screw
14. Catch
15. Nut
16. Rubber catch
17. Screw (2)
18. Nut (2)

Figure 4-99. Tool Box.

TA099839

(5) Remove four capscrews (6) and nuts (7), and remove tool box (8).

(6) Install tool box by reversing steps (1) through (5).

*b. Disassembly and Assembly.* Refer to figure 4-99 and remove and install any items that need replacement.

**4-59. Tank Body (Figs, 4-95 and 4-96)**

Damage to the tank body and evidence of leaks and bent or broken metal parts will be reported to the responsible maintenance level for correction.

**4-60. Manhole and Fill Cover (Fig. 4-100)**

**WARNING**

**Always relieve pressure in tank shell before opening manhole cover.**

*a. Adjustment (Fig. 4-100).*

(1) Remove padlock, release safety latch (13), and open fill cover (7).

(2) Loosen locknut (5) on underside of fill cover and close fill cover.

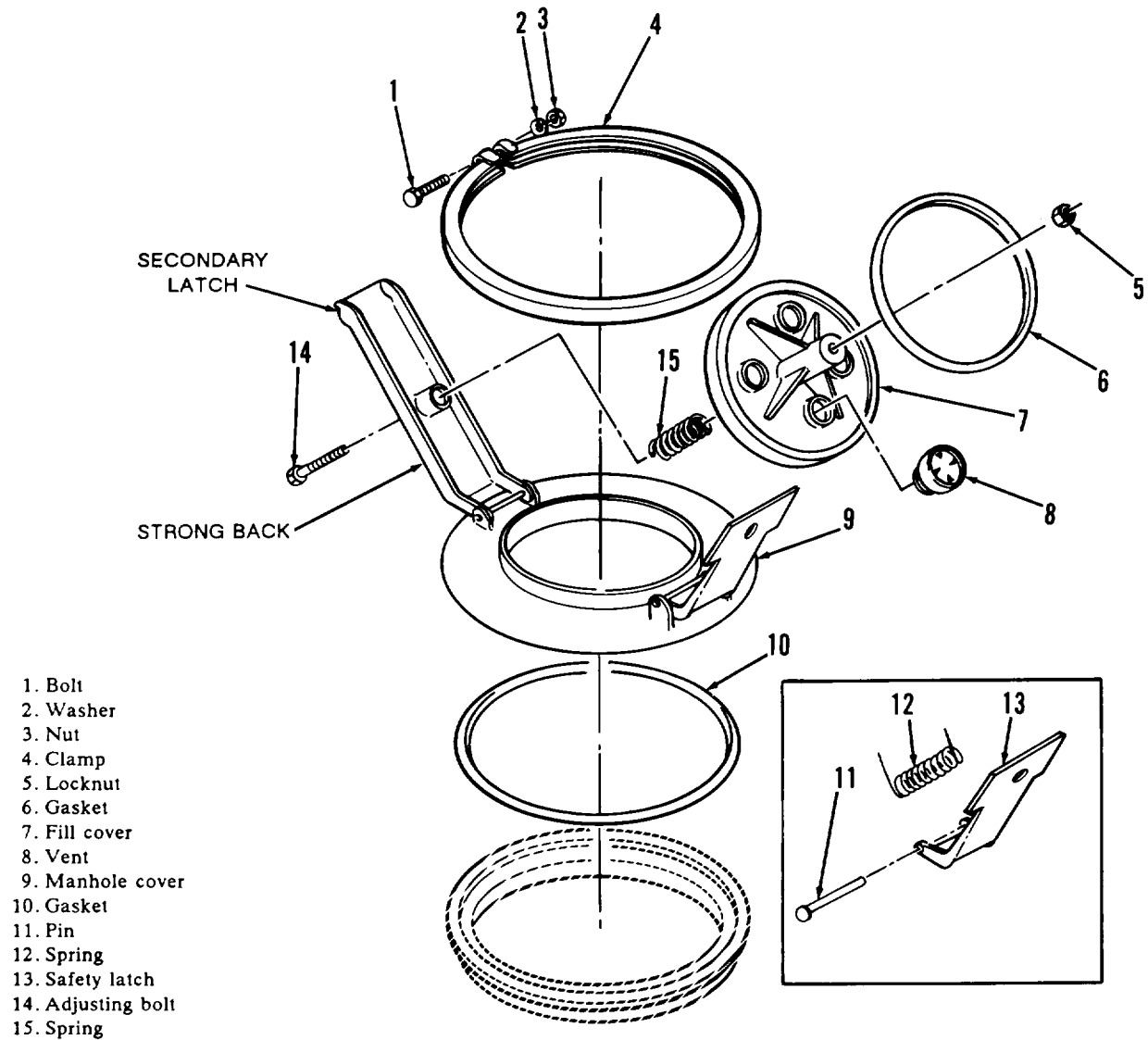

**Figure 4-100. Manhole and Fill Cover.**

TA099840

(3) Loosen or tighten adjusting bolt (14) in center of strongback until latch just clears the secondary latch on end of strongback.

(4) Open fill cover (7) and tighten locknut (5).

(5) Close cover and recheck clearances of latch and strongback.

*b. Removal.*

(1) Remove bolt (1), washer (2), and nut (3) that holds manhole clamp (4) to semitrailer.

(2) Remove clamp ring to free manhole cover (9) and gasket (10).

*c. Disassembly.*

(1) Remove locknut (5) and remove fill cover (7), adjusting bolt (14), and spring (15).

(2) Remove vent (8) and gasket (6) from fill cover (7). If gummed up with product, or if there are signs of obvious damage, replace vent.

(3) Using a punch and hammer, drive pin (11) from safety latch (13). Remove spring (12).

*d. Assembly.*

(1) Position safety latch (13) and spring (12) on manhole cover (9). Install pin (11). Peen end of pin to secure safety latch to manhole cover.

(2) Install gasket (6) and vent (8) to fill cover (7).

(3) Install assembled fill cover to manhole (9) using adjusting bolt (14), spring (15), and locknut (5).

(4) Adjust (step *a*).

*e. Installation.*

(1) Position manhole cover gasket (10). Set manhole cover (9) in place and retain with clamp (4).

(2) Secure clamp with bolt (1), washer (2), and nut (3).

**4-61. Ladder and Drain (Figs. 4-95 and 4-96)**

*a. Inspection.*

(1) Check ladder and drain pipe connections on top of semitrailer to ensure that drain holes are open and free of debris.

(2) Check bolts for tightness at top of semitrailer and at bottom.

(3) Check welds on bolt flange on both top and bottom to make sure they are not loose or cracked.

*b. Service.*

(1) Remove any debris from top of semitrailer that may plug drain holes.

(2) Tighten bolts if loose.

(3) If any welds are cracked or loose, notify direct support maintenance for repair.

*c. Replacement.*

(1) *Ladder.* Remove eight capscrews and nuts and remove ladder. Install and position new ladder on tank. Secure with eight capscrews and nuts.

(2) *Drain Pipes.* Remove four capscrews and nuts on each drain pipe. Remove drain pipe. Install and position new drain pipe on tank, and secure with four capscrews and nuts.

**Section XVI. MAINTENANCE OF BODY ACCESSORY ITEMS**

**4-62. Bulk Transfer Hose Assembly**

*a. Removal.* Remove retainer clips from hose retainers (figs. 4-95 and 4-96), slide bar aside, and remove hose from trough.

*b. Installation.* Put hose in trough, move bar into position, and attach retainer clip.

**4-63. Grounding Rod (Figs. 4-95 and 4-96)**

If grounding rod is bent, straighten rod. Replace any damaged or missing chain and clip pin part.

**4-64. Fuel Level Gage (Figs. 4-95 and 4-96)**

If wooden fuel gage is unreadable or broken, replace. If cap, chain, or storage tube is missing or damaged, replace.

**4-65. Nozzle, Adapter, and Sampling Bags (M970 and M970A1)**

The tool box contains four bags for the underwing and overwing nozzle, two canvas protector bags for ends of hoses, closed circuit nozzle, and adapter and sampling kit. If any bags are worn or missing, replace.

**4-66. Reflectors**

*a. General.* Reflectors are located on the front, near the marker lights, and on both ends of the hose trough.

*b. Replacement.*

(1) Peel or scrape old reflector off semitrailer. Clean surface thoroughly.

(2) Peel off reflector backing and place new reflector in position.

**4-67. Identification and Instruction Plates (Para 1-11)****NOTE**

**Some instruction plates have been mounted with rivets. Drill rivets out and replace with proper machine screw.**

*a. Removal.* Remove screws holding plates to semitrailer.

*b. Installation.* Fasten new plates to semitrailer with screws.

**4-68. Fire Extinguisher Mounting Bracket (Figs. 4-95 and 4-96)**

*a. Service.* Check tightness of mounting bolts and for damage to retainer bracket.

*b. Replacement.*

(1) Remove protective cover and fire extinguisher.

(2) Remove four self-locking nuts, flatwashers, and capscrews. Remove mounting bracket.

(3) Install new mounting bracket and fasten with four capscrews, flatwashers, and self-locking nuts.

(4) Install fire extinguisher and protective cover.

**Section XVII. MAINTENANCE OF ENGINE****4-69. General.**

Detailed information concerning maintenance of the engine assembly is found in Chapters 5 and 7 of this manual. Procedures covering replacement of engine components and accessories are contained in subsequent paragraphs of this section.

**4-70. General Engine Servicing****WARNING**

**Dry cleaning solvent P-D-680 is toxic and flammable. Always wear protective goggles and gloves, and use only in a well-ventilated area. Avoid contact with skin, eyes, and clothes, and DO NOT breathe vapors. DO NOT use near open flame or excessive heat. The solvent's flash point is 100°F-138°F (38°C-59°C). If you become dizzy while using cleaning solvent, immediately get fresh air and medical help. If solvent contacts eyes,**

**Immediately wash your eyes with water and get medical aid.**

*a.* Periodically clean all outside surfaces of the engine with dry cleaning solvent (item 11, Appendix E).

*b.* Clean battery and cables (para 4-23).

**4-71. Crankcase, Cylinder Head, and Block**

*a. Draining Crankcase.*

(1) Place suitable container under crankcase drain plug and remove drain plug (fig. 4-101). Drain oil into container.

(2) When oil is completely drained, replace the drain plug and refill crankcase with six quarts of oil. If filter is replaced, add one additional pint of oil. Refer to Lubrication Chart (figs. 3-1 through 3-6) for correct type of oil. Wipe up any spills and dispose of used oil according to regulations.

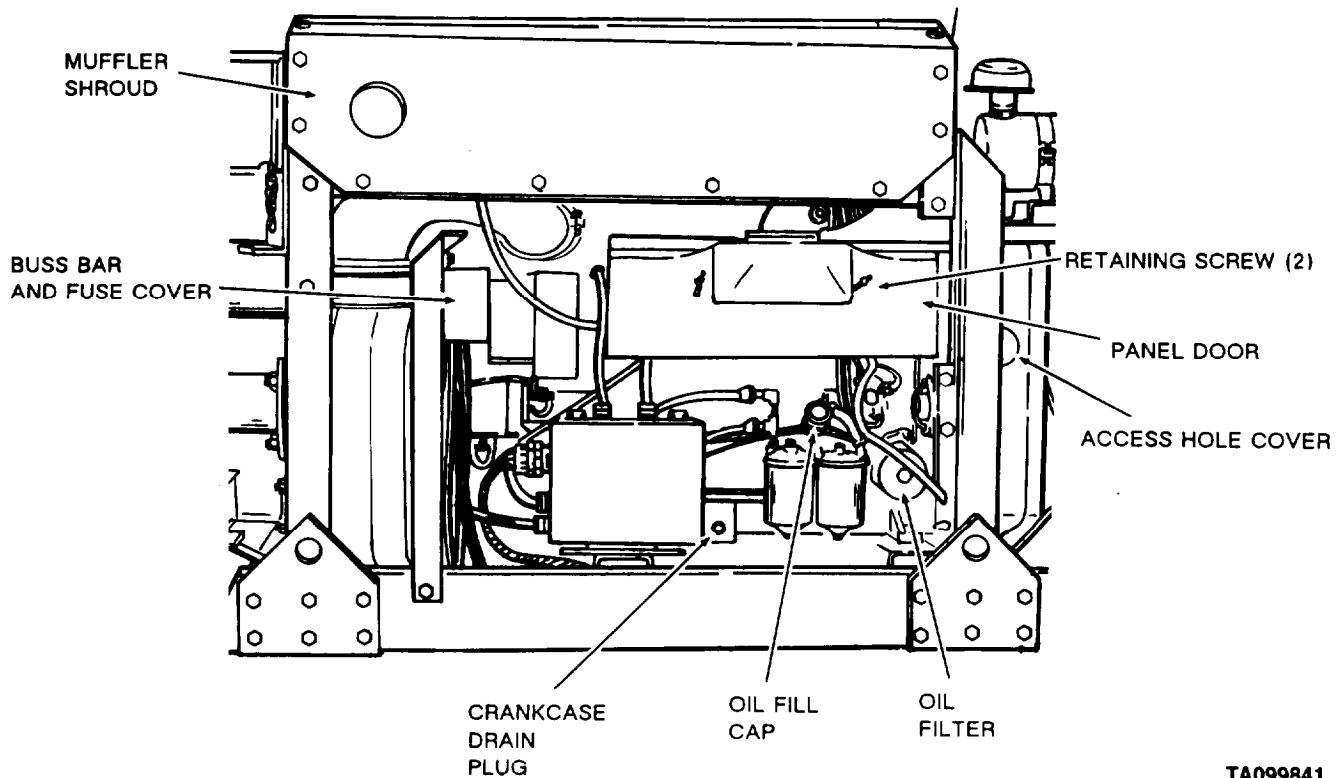

Figure 4-101. Right Side View of Engine.

TA099841

**WARNING**

Dry cleaning solvent P-D-680 is toxic and flammable. Always wear protective goggles and gloves, and use only in a well-ventilated area. Avoid contact with skin, eyes, and clothes, and DO NOT breathe vapors. DO NOT use near open flame or excessive heat. The solvent's flash point is 100°F-138°F (38°C-59°C). If you become dizzy while using cleaning solvent, immediately get fresh air and medical help. If solvent contacts eyes, immediately wash your eyes with water and get medical aid.

**CAUTION**

Do not get solvent on rubber parts. Damage to parts may result.

*b. Cleaning.* Periodically remove panel door (fig. 4-101) by unscrewing two retaining screws and thoroughly clean all visible components of crankcase, cylinder head, and block. Use a stiff brush and dry cleaning solvent (item 11, Appendix E). Wipe dry after cleaning.

*c. Service.* Check for any loose or missing bolts. Replace any bolts which are missing.

**4-72. Engine Lubrication System**

*a. Oil Filter Replacement.*

(1) Place a suitable container under oil filter. Use a wrench to turn filter (fig. 4-101) counterclockwise to remove. Remove filter and discard.

(2) Clean filter mounting area.

(3) Coat gasket on new filter with clean oil. Install new filter by turning clockwise on mounting shaft.

(4) Hand-tighten filter until gasket touches mounting base. Tighten an additional ½-turn. DO NOT overtighten.

(5) Add one additional pint of oil to crankcase. Refer to Lubrication Chart (figs. 3-1 through 3-6) for correct type of oil.

*b. Oil Fill Cap Gasket Replacement.* Remove engine oil dipstick from engine. Inspect gasket in dipstick cap. Replace gasket if damaged.

**4-73. Engine Fuel System**

*a. Testing Electric Fuel Pumps on Equipment.*

(1) Perform operational test for each pump individually. Each pump should pump at 6-7 psi as registered on an accurate fuel pressure gage.

(2) Connect fuel pressure gage to output port of pump.

(3) Turn engine switch to RUN position. Pressure gage should register 6-7 psi.

(4) Replace defective pumps.

b. *Servicing Fuel System (Fig. 4-102).*

**CAUTION**

**Drain plug on fuel filters can take only a limited amount of torque. Use two wrenches in combination for breaking plugs loose and for final tightening.**

(1) *Draining Water From Fuel System.*

(a) Daily, drain water from both fuel filters. Loosen but do not remove drain plug (fig. 4-102) at bottom of filter. Allow fuel to drain until clear of water. Tighten drain plug.

(b) If fuel system is badly contaminated with water, drain water and fuel from tank (step (2)).

(2) *Draining Fuel Tank.*

(a) Place a suitable container under fuel tank and remove drain plug (fig. 4-105). Drain fuel into a suitable container.

(b) Flush tank with clean diesel fuel and replace drain plug.

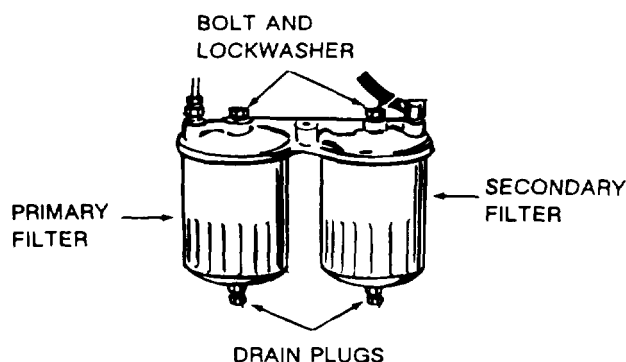

TA099842

Figure 4-102. Location of Drain Plugs on Fuel Filters.

(c) Refill tank with fresh fuel. Use No. 1 diesel fuel (item 15, Appendix E) for operation below 32°F and No. 2 diesel fuel (item 14, Appendix E) for operation above 32°F.

c. *Servicing Fuel Filters.* Service primary fuel filter and electric fuel pump filters after every 600 hours. Service secondary fuel filter after every 3000 hours. Service filters sooner if loss of power is indicated. Service first the fuel pump filters and then the primary and secondary filters.

(1) *Electric Fuel Pump Filter (Fig. 4-103).*

(a) Place a suitable container under pump to collect any fuel that will spill from fuel pump.

(b) Use a wrench to turn bottom cover (fig. 4-103) from bayonet pins. Twist cover off.

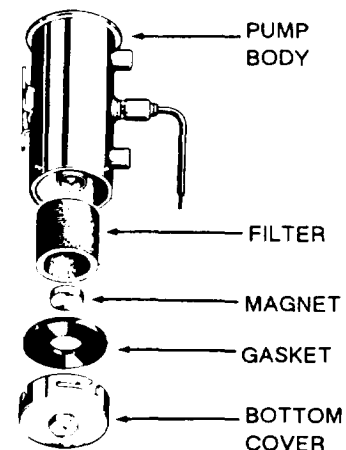

TA099843

Figure 4-103. Electric Fuel Pump Filter

**WARNING**

Dry cleaning solvent P-D-680 is toxic and flammable. Always wear protective goggles and gloves, and use only in a well-ventilated area. Avoid contact with skin, eyes, and clothes, and DO NOT breathe vapors. DO NOT use near open flame or excessive heat. The solvent's flash point is 100°F-138°F (38°C-59°C). If you become dizzy while using cleaning solvent, immediately get fresh air and medical help. If solvent contacts eyes, immediately wash your eyes with water and get medical aid.

(c) Remove filter, magnet, and cover gasket. Replace filter or clean in dry cleaning solvent (item 11, Appendix E) and blow dry. Discard gasket. Install magnet, new gasket, filter, and tighten cover.

(2) *Primary and Secondary Fuel Filters* (fig. 4-102).

(a) Place a suitable container under fuel filters to collect any fuel.

(b) Remove drain plugs and drain fuel into containers.

(c) Remove bolt and lockwasher (fig. 4-102) and remove filter. Dispose of contaminated filters.

(d) Place new filter in position and tighten bolt until gasket touches base. Then tighten bolt an additional 1½ to 2 turns.

d. *Replacement of Electric Fuel Pumps.* The fuel pumps are located at left rear side of engine and are mounted on the rear firewall (fig. 4-104).

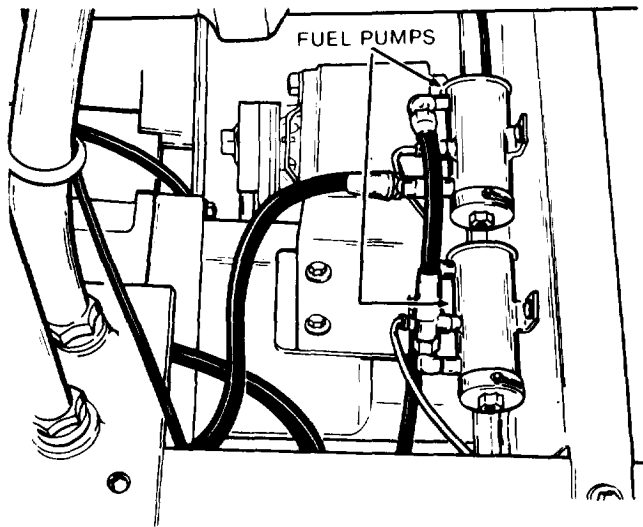

TA099844

**Figure 4-104. Location of Fuel Pumps.**

(1) *Removal.*

(a) Tag and disconnect fuel lines from fuel pump. Keep fuel lines clean. Plug lines to prevent contamination.

(b) Remove two self-locking nuts, lockwashers, and capscrews that mount fuel pump to firewall. Remove fuel pump.

(c) Tag and disconnect electrical lead from fuel pump.

(2) *Installation.* Install fuel pump in reverse order of steps (a) through (c).

e. *Replacement of Fuel Lines and Fittings.* All fuel lines are hose assemblies. Simply remove line that needs replacement, and replace with a new line assembly. See figure 4-105 for location of all hose assemblies and fittings.

f. *Replacement of Fuel Tank.*

(1) Drain fuel tank (b above).

(2) Remove two upper fuel lines, elbows, and bushings from top of fuel tank (fig. 4-105).

(3) Remove four screws and washers that fasten fuel tank straps. Disconnect ground cable.

(4) Remove straps and fuel tank.

(5) Remove ground cable from tank.

(6) Replace fuel tank in reverse order of steps (2) through (5).

(7) Fill fuel tank with proper fuel (para 2-10).

g. *Bleeding Fuel System.* Before initial start, or after replacing fuel filters, fuel lines, fuel tank, or fuel pumps, bleed the fuel system of air:

(1) Disconnect/loosen the fuel return line at top of injector pump (fig. 4-105).

(2) Turn engine switch to RUN to energize the electrical system and fuel pumps.

(3) Allow the fuel pumps to run until there are no air bubbles in the fuel flowing from the fuel return line fitting.

(4) Connect the fuel return line.

**4-74. Air Cleaner**

a. *Removal* (Fig. 4-106).

(1) Loosen clamp on engine air intake hose at air cleaner and disconnect hose from air cleaner.

(2) Open straps on air cleaner (fig. 4-106) and remove air cleaner.

b. *Installation* (Fig. 4-106).

(1) Install air intake hose on air cleaner outlet and tighten clamp.

(2) Install air cleaner in mounting straps. Tighten straps.

(3) Tighten hose clamp.



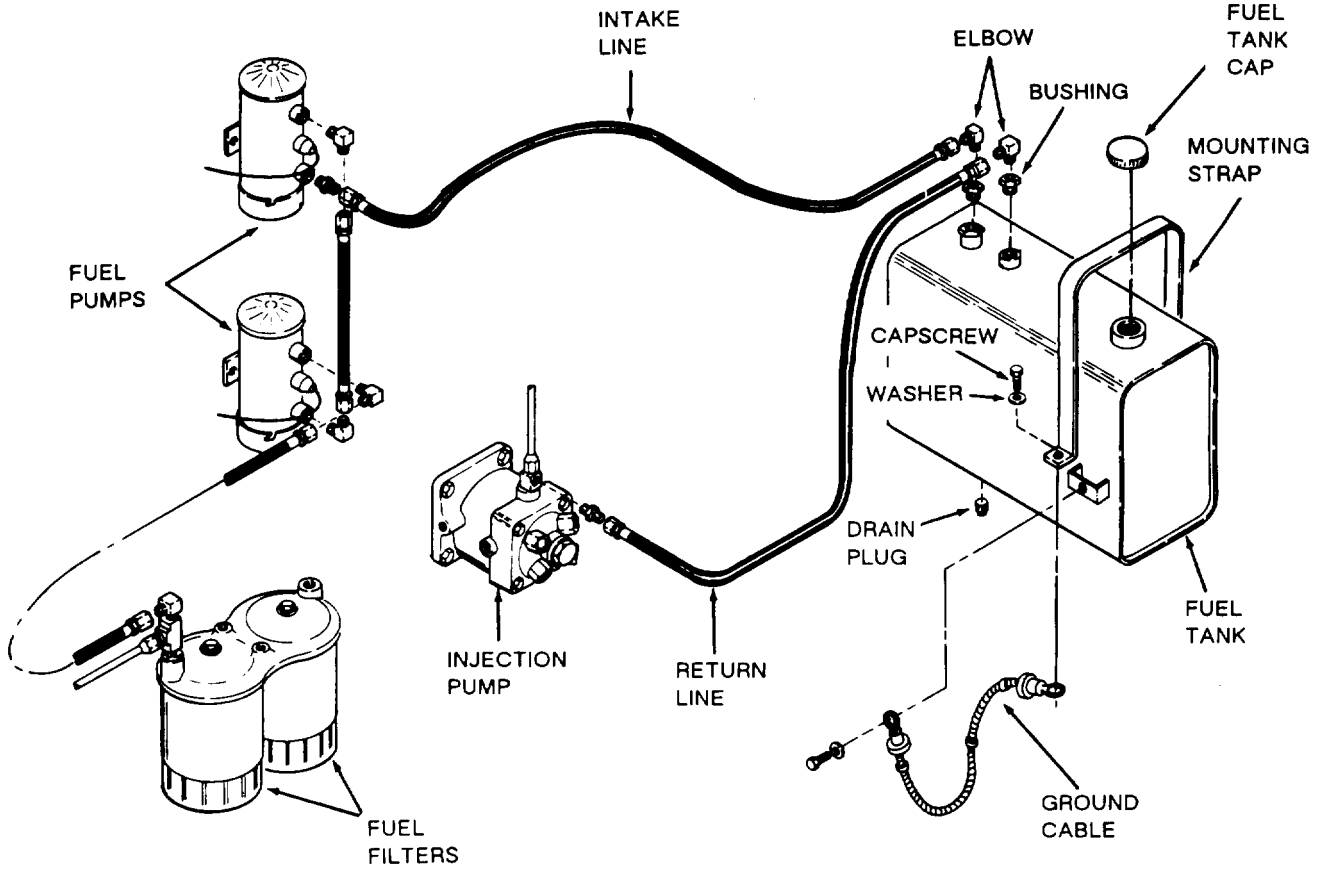

TA099845

Figure 4-105. Fuel Tank and Lines.

4-75. Engine Throttle Linkage (Fig. 4-1 07)

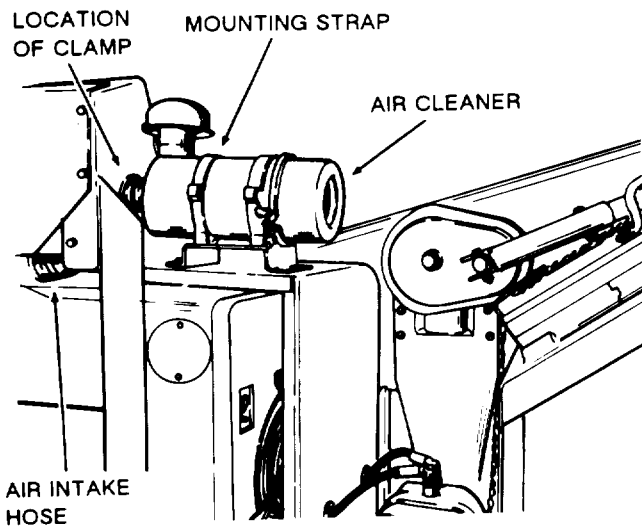

TA099846

Figure 4-106. Engine Air Cleaner

**WARNING**

Dry cleaning solvent P-D-680 is toxic and flammable. Always wear protective goggles and gloves, and use only in a well-ventilated area. Avoid contact with skin, eyes, and clothes, and DO NOT breathe vapors. DO NOT use near open flame or excessive heat. The solvent's flash point is 100°F-138°F (38°C-59°C). If you become dizzy while using cleaning solvent, immediately get fresh air and medical help. If solvent contacts eyes, immediately wash your eyes with water and get medical aid.

a. Service.

(1) Clean linkage, where accessible, with dry cleaning solvent (item 11, Appendix E). Wipe dry with a clean cloth.

(2) Check throttle cable for adjustment.

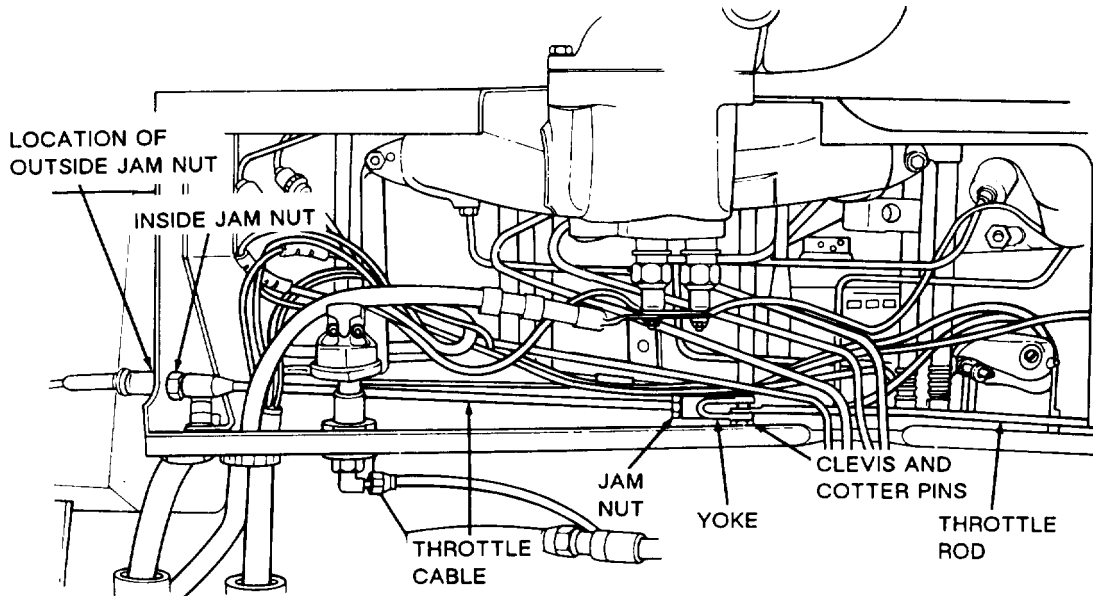

Figure 4-107. Throttle Linkage Connection at Engine.

TA502360

b. Throttle Cable Adjustment.

**NOTE**

**Engine should be adjusted to low idle speed (900 rpm).**

(1) Remove engine panel door by loosening the two retaining screws (fig. 4-101) and lifting door out.

(2) Start engine (para 2-10).

(3) To increase engine speed, loosen the throttle jam nut on the outside of the panel and tighten the inside jam nut (fig. 4-107).

(4) To decrease engine speed, loosen the inside jam nut and tighten the outside jam nut.

(5) Shut off engine (para 2-10).

(6) Replace engine panel door.

c. Removal.

(1) Remove engine panel door by loosening the two retaining screws (fig. 4-101) and lifting door out.

(2) Remove clevis pin and cotter pin (fig. 4-107) from end of throttle cable. Disconnect throttle cable from throttle rod.

(3) Remove yoke and jam nut from end of throttle cable.

(4) Remove inside jam nut and pull cable through shrouding.

(5) Remove screw and handle from cable (fig. 4-108).

(6) Remove packing nut, jam nut, and washer.

(7) Pull cable through channel of control panel.

(8) Cut and remove straps that support cable.

(9) Remove cable.

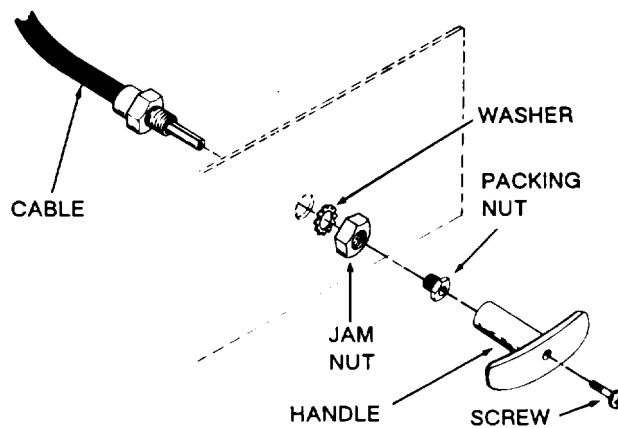

TA099848

Figure 4-108. Throttle Linkage Connection at Control Panel.

*d. Installation.*

(1) Remove screw, handle, packing nut, one nut, and washer from handle end of cable.

(2) On opposite end remove one jam nut.

(3) Install cable through channel of control panel. Replace the jam nut, packing nut, handle, and screw.

(4) Thread cable through hole in engine shrouding. Replace inside jam nut (fig. 4-107), but do not tighten.

(5) Replace jam nut and yoke and attach yoke to throttle rod with clevis pin and cotter pin.

(6) Start engine (para 2-10).

(7) Adjust engine speed to low idle (900 rpm) (step *b*).

(8) Shut off engine (para 2-10).

(9) Replace engine cover panel.

(10) Replace straps.

**4-76. Governor Assembly (Fig. 4-109)***a. Service.***WARNING**

**Dry cleaning solvent P-D-680 is toxic and flammable. Always wear protective goggles and gloves, and use only in a well-ventilated area. Avoid contact with skin, eyes, and clothes, and DO NOT breathe vapors. DO NOT use near open flame or excessive heat. The solvent's flash point is 100°F-138°F (38°C-59°C). If you become dizzy while using cleaning solvent, immediately get fresh air and medical help. If solvent contacts eyes, immediately wash your eyes with water and get medical aid.**

(1) Clean all accessible linkage with dry cleaning solvent (item 11, Appendix E). Wipe dry with a clean cloth.

(2) Periodically lubricate the ball joints (fig. 4-109) with OE-10 oil (item 21, Appendix E). Remove the engine panel door (fig. 4-101) to gain access to the ball joints.

*b. Governor Sensitivity Adjustment (No Engine Surge).*

(1) Start engine (para 2-10).

(2) Locate access hole cover on side of engine blower housing and remove cover (fig. 4-101).

(3) Locate the governor arm assembly (fig. 4-109).

(4) For a coarse adjustment, relocate the spring in the notches in the governor arm.

(5) For a fine adjustment, insert a screwdriver through the access hole to ratchet-type base of the governor arm. Turn the ratchet hub clockwise to decrease sensitivity or counterclockwise to increase sensitivity.

(6) Adjust for maximum sensitivity without a surging condition.

(7) Stop engine (para 2-10).

**4-77. Engine Muffler/Exhaust***a. Removal (Fig. 4-110).*

(1) Remove muffler shroud by removing ten capscrews that secure shroud to panels (fig. 4-101).

(2) Loosen clamp (fig. 4-110) on the exhaust pipe by loosening a bolt and a nut.

(3) Remove two muffler clamps securing muffler to mounting plate. Remove muffler.

(4) Remove two capscrews and lockwashers from the exhaust pipe at the manifold. Remove exhaust pipe adapter and gasket.

*b. Installation (Fig. 4-110).*

(1) Install a new gasket between exhaust pipe and exhaust manifold. Secure exhaust pipe and adapter to manifold with two capscrews and lockwashers.

(2) Put exhaust pipe clamp over end of exhaust pipe and insert muffler inlet into exhaust pipe. Do not tighten clamp.

(3) Replace muffler clamps and tighten.

(4) Tighten exhaust pipe clamp.

(5) Replace muffler shroud, securing with ten capscrews (fig. 4-101).

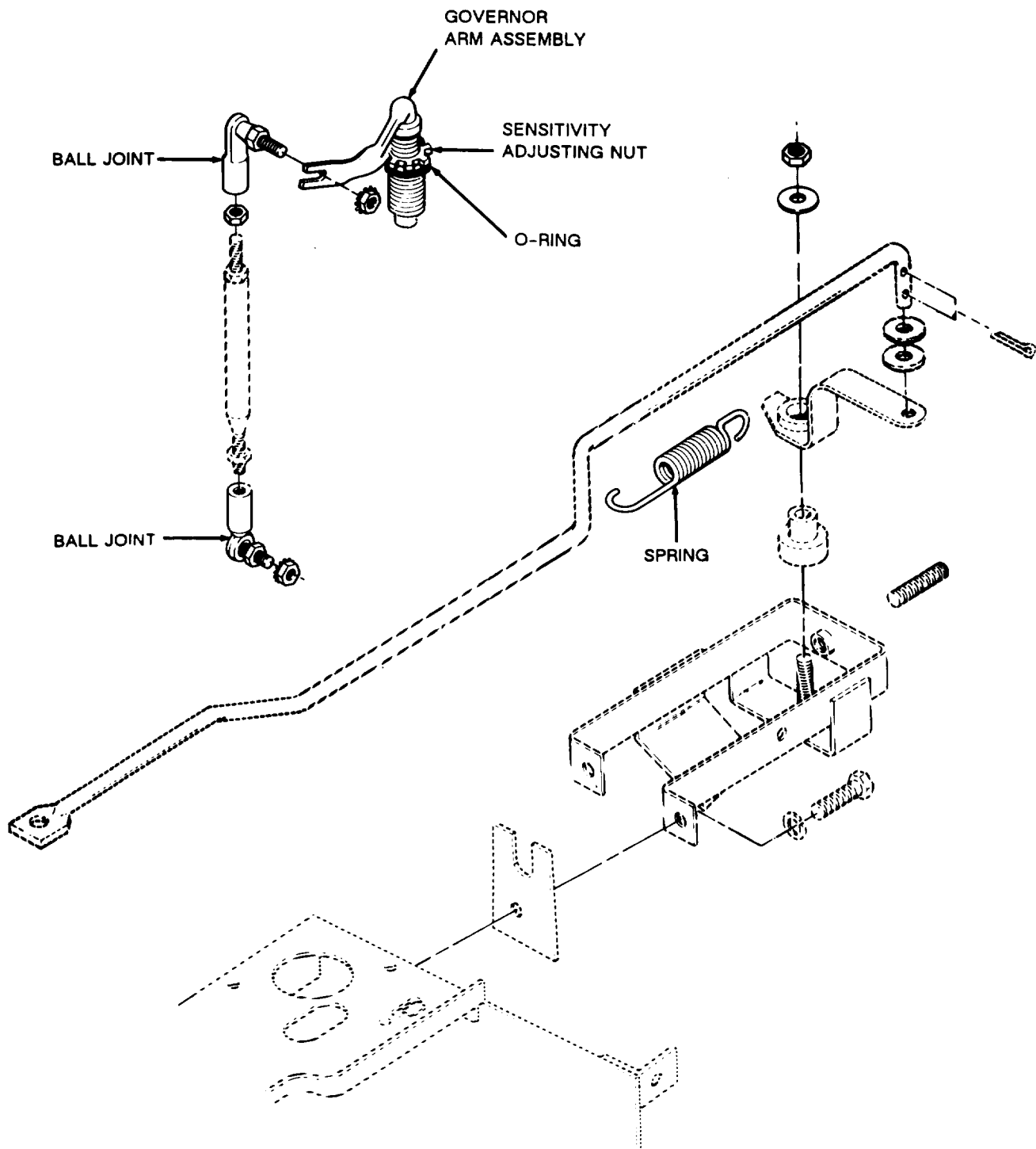
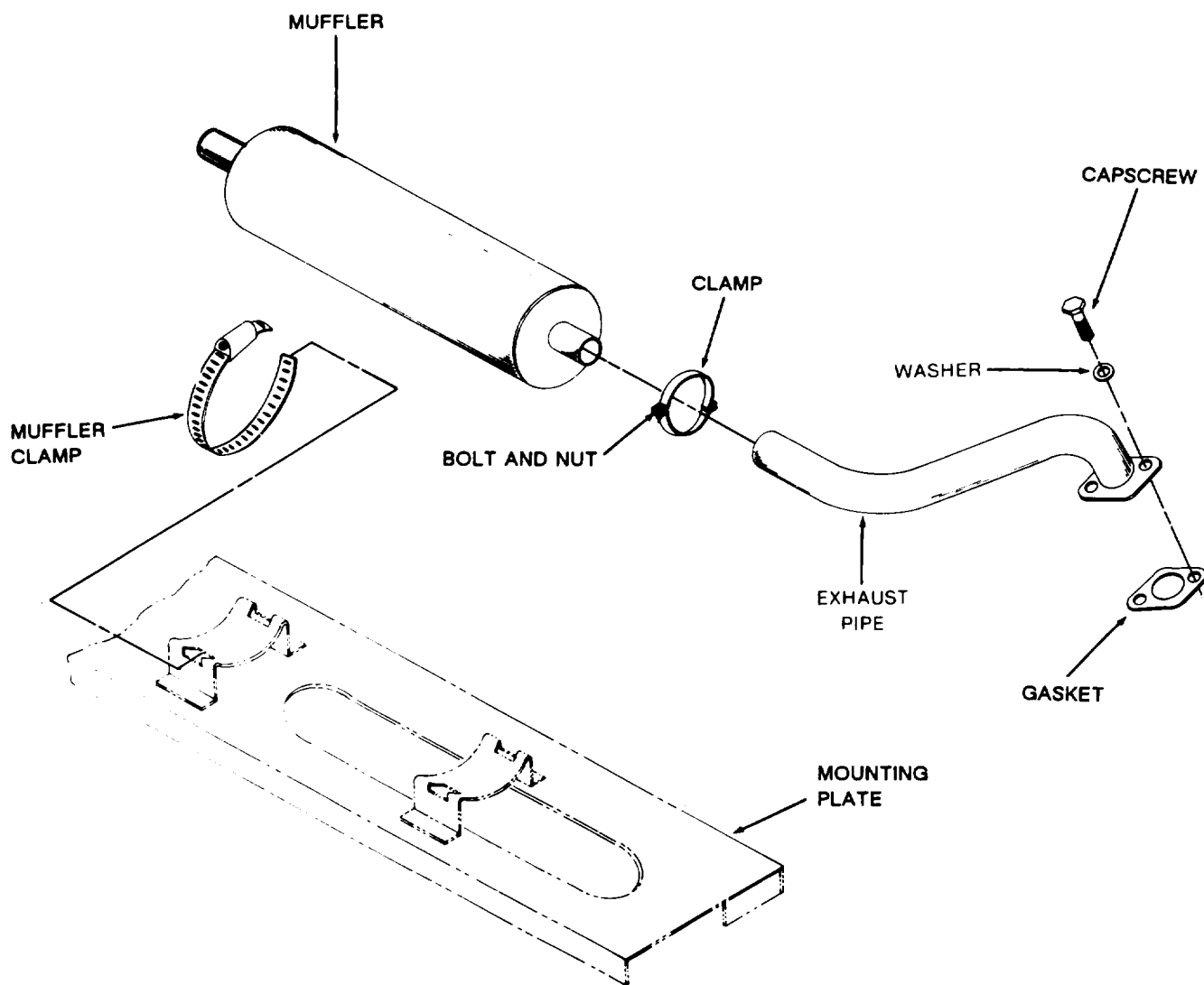

Figure 4-109. Governor Assembly.

TA504715



TA099850

Figure 4-110. Exhaust Pipe and Muffler.

**4-78. Engine Alternator**

a. *Removal of Alternator (Fig. 4-111).*

**WARNING**

- **When performing electrical maintenance, ALWAYS disconnect intervehicular electrical cable from semitrailer, and negative battery cables at batteries. Failure to follow this warning may create a spark and explo-**

**sion, resulting in serious injury or death to personnel.**

- **Alternator weighs approximately 25 pounds. Use caution when removing or installing the alternator to avoid injury to personnel or damage to components.**

(1) Disconnect negative, then positive cable from battery (fig. 4-37).

(2) Remove two screws and nuts from buss bar cover. Remove cover.

- 1. Flatwasher
- 2. Lockwasher
- 3. Capscrew
- 4. Adjusting bracket
- 5. Lockwasher (2)
- 6. Nut (2)
- 7. Capscrew (2)
- 8. Bracket
- 9. Flatwasher
- 10. Lockwasher (2)
- 11. Nut (2)
- 12. Capscrew
- 13. Capscrew
- 14. Flatwasher (4)
- 15. Capscrew (4)
- 16. Mounting bracket
- 17. Pulley
- 18. Alternator Belt
- 19. Alternator

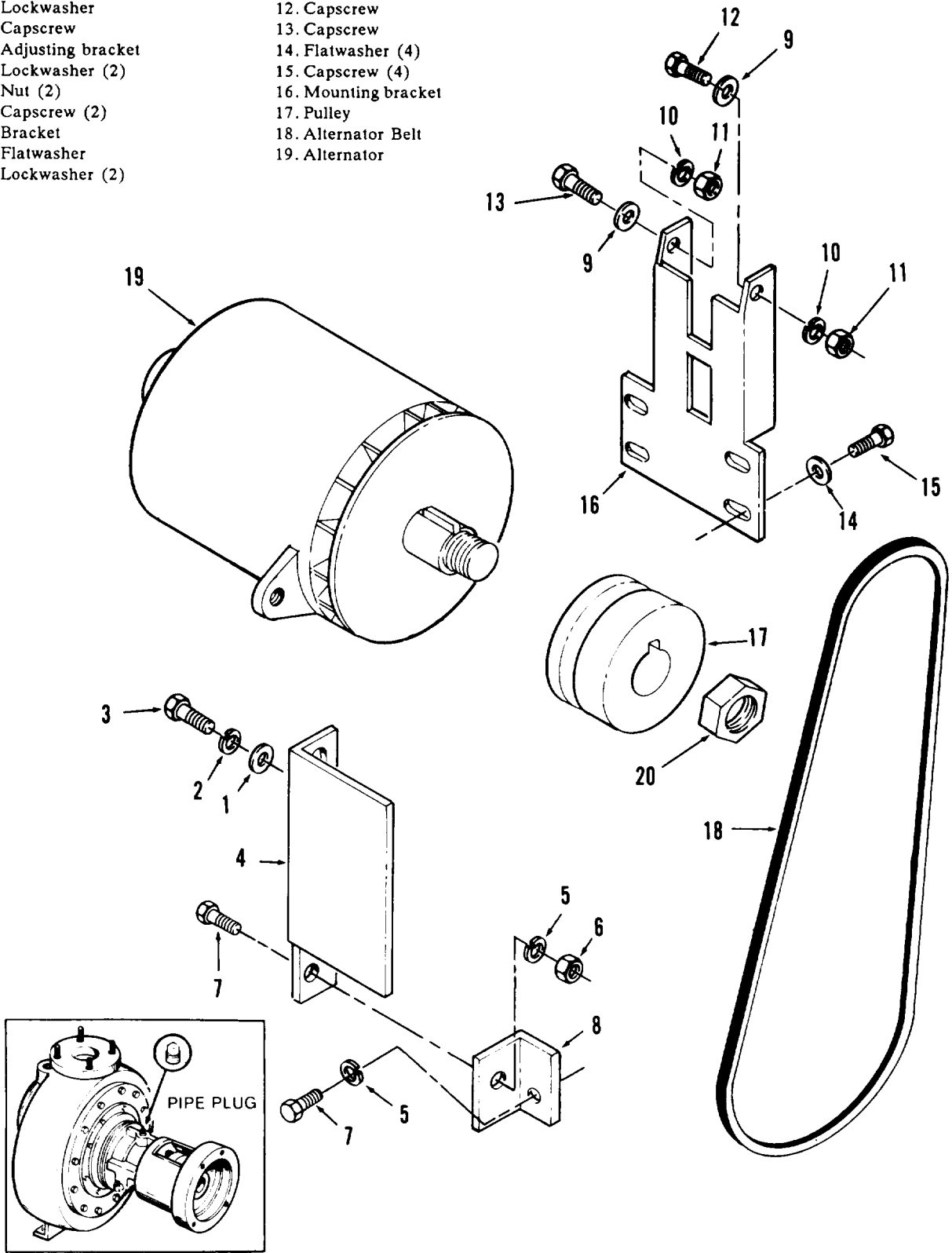

Figure 4-111. Alternator Installation (M967, M969, M970 Arrangement).

TA502384

(3) Unscrew pipe plug (fig. 4-111) directly below alternator from the intermediate housing.

(4) Remove bolt (3), lockwasher (2), and flatwasher (1) securing alternator to adjusting bracket (4).

(5) Remove bolt (7), lockwasher (5), and nut (6), then remove the adjusting bracket (4).

(6) Pull down on alternator to release tension on alternator belt. Remove alternator belt from pulley.

(7) From underneath semitrailer, remove two bolts (12 and 13), flatwashers (9), lockwashers (10), and nuts (11).

(8) Remove ground cable (nearest) from alternator.

(9) Pull alternator from mounting bracket (16). Turn alternator and remove positive cable.

(10) Remove alternator.

*b. Adjustment of Alternator Drive Belt (Fig. 4-112).*

(1) Loosen alternator adjusting bolt (3, fig. 4-111) and mounting bolts (12 and 13) securing alternator to mounting bracket (16).

(2) Insert a crowbar (fig. 4-112) between alternator and the pump housing. Be sure that lower end of bar will bear against the pump housing. Pull UP on the bar and apply sufficient force to obtain proper belt tension. Proper belt tension is 1/8 to 1/4-inch deflection in the belt midway between the two pulleys.

(3) Tighten adjusting screw (3, fig. 4-111) and two mounting bolts (12 and 13).

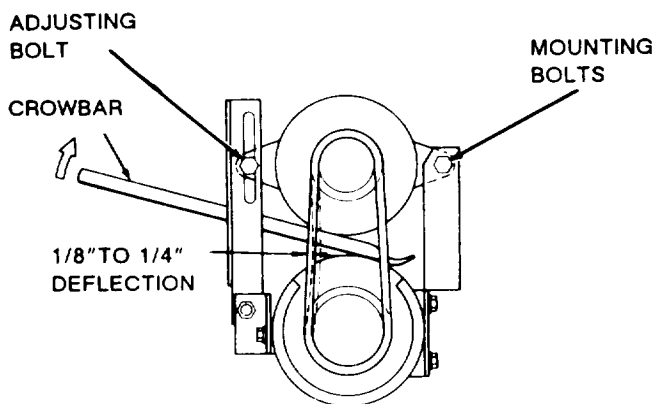

TA099852

**Figure 4-112. Belt Deflection Adjustment.**

*c. Replacement of Alternator Pulley (Fig. 4-111).*

(1) Remove alternator (19) (para 4-78).

(2) Clamp pulley in a soft jaw vise.

(3) Remove shoulder nut (20) from alternator rotor shaft.

(4) Remove pulley (17) and key from rotor shaft.

(5) Install new pulley in reverse order.

(6) Install alternator (19) (step d).

*d. Installation of Alternator (Fig. 4-111).*

(1) Connect the positive cable to the positive terminal on the alternator and the negative cable to the negative terminal on alternator (19).

(2) Locate sliding bushing in one of ears on the alternator. Move bushing so it is flush with the inside of ear. This will give more clearance between the ears to facilitate installation of alternator to the mounting bracket (16, fig. 4-111).

(3) Install bolt (13) and washer (9) into bushing on alternator.

(4) Install alternator over ears of mounting bracket (16). While doing this, have a second person replace both bolts (12 and 13) through ears of alternator and mounting bracket. Replace washers (10) and nuts (11). Do not tighten.

(5) Replace alternator belt (18) over pulley (17).

(6) Replace adjusting bracket (4) on alternator with capscrew (3), lockwasher (2), and flatwasher. Do not tighten.

(7) Secure adjusting bracket (4) to bracket (8) with capscrew (7), lockwasher (5), and nut (6).

(8) Replace buss bar box cover and secure it with two capscrews and nuts.

(9) Adjust alternator belt (para 4-79).

(10) Connect positive and negative battery cables to battery.

*Replacement of Alternator Drive Belt (M967A1, M969A1, and M970A1) (Figs. 4-113 through 4-122).*

(1) Remove any broken belt fragments from the drive area. Remove the capscrews and lockwashers securing the flexible element drive ring (fig. 4-113).

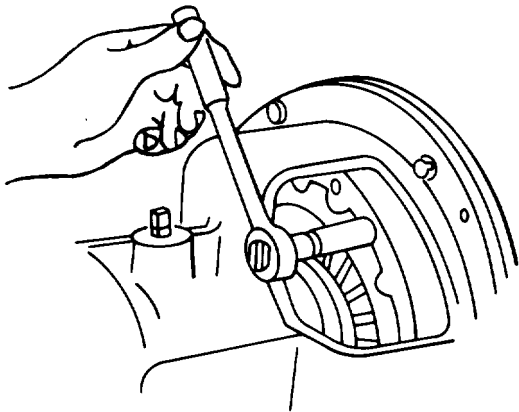

TA222976

**Figure 4-113. Drive Ring Capscrew Removal.**

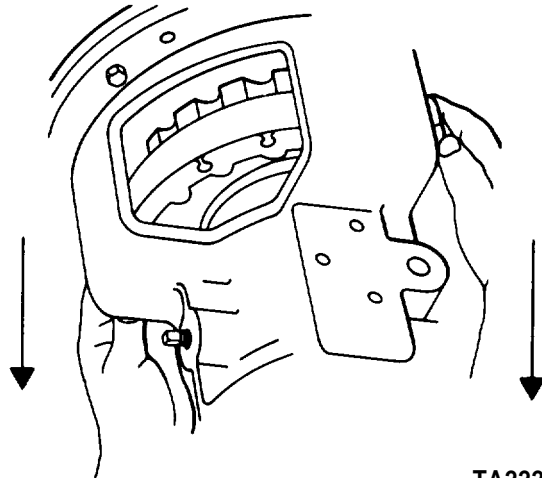

TA222978

**Figure 4-115. Pulling Drive Ring Back.**

(2) Use two of the four drive ring capscrews as jacking screws in the threaded holes around the drive ring. Turn them in to force the ring out from the element. Be certain to locate the jacking screws across from each other (180°). Turn the jacking screws in evenly to remove drive ring (fig. 4-114).

(3) Pull the loosened drive ring back over the rubber element (fig. 4-115).

(4) Compress the replacement belt and work it behind the flexible rubber element (fig. 4-116).

(5) Using two suitable prying bars, pry the flexible rubber element away from the engine and maneuver the bottom of the belt down past the centerline of the pump shaft (fig. 4-117).

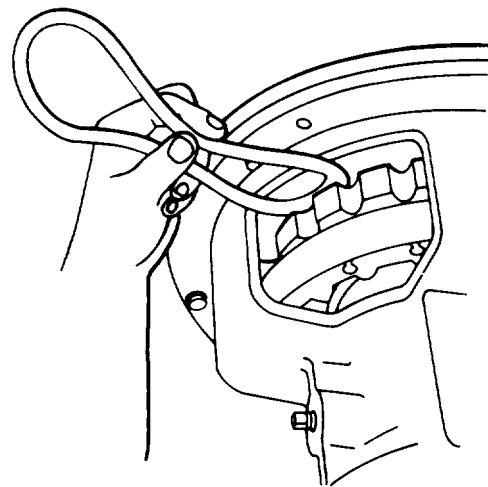

TA222979

**Figure 4-116. Compressing Alternator Drive Belt.**

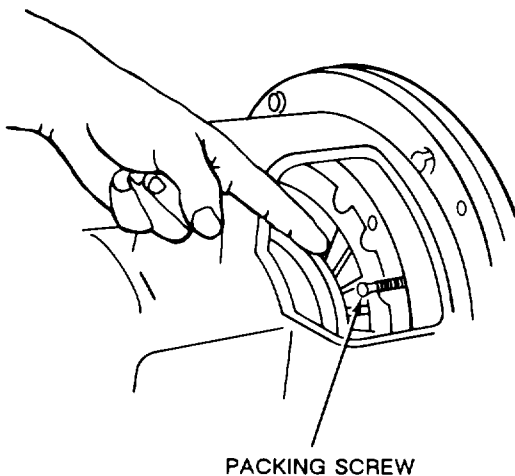

TA222977

**Figure 4-114. Jacking Screws Location.**

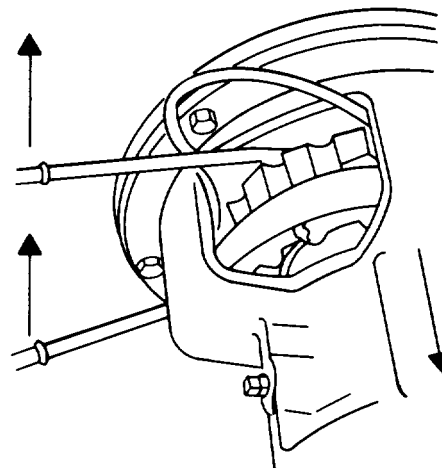

TA222980

**Figure 4-117. Prying Flexible Rubber Element.**



(6) After the belt has been maneuvered around the flexible rubber element, pull it through the inside of the drive ring (fig. 4-118).

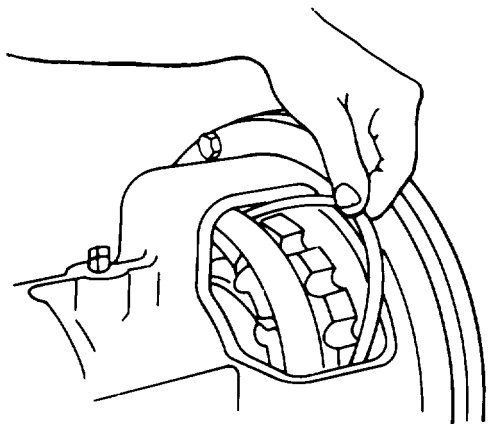

TA222981

**Figure 4-118. Pulling Belt Through Drive Ring.**

(7) Align the drive ring non-threaded mounting holes with the threaded flywheel holes and engage the capscrews with lockwashers finger tight. Do not fully tighten at this time (fig. 4-120).

(8) Slide the drive ring back into position on the flexible rubber element and pull the belt into the drive sheave "V" groove (fig. 4-119).

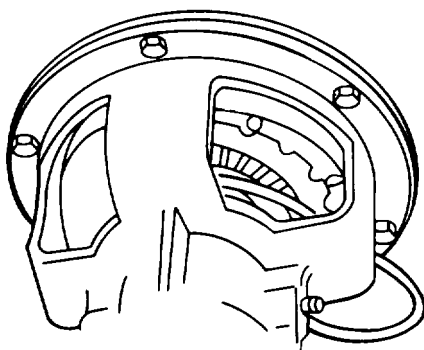

TA222982

**Figure 4-119. Positioning Belt on Drive Sheave.**

(9) Check the arrangement of the drive belt for alinement with the alternator (fig. 4-121).

(10) Retighten the drive ring capscrews with lockwashers evenly in an alternating pattern. Tighten the capscrews with lockwashers to 10.5 lb.-ft. (126 lb.-in.) (fig. 4-122).

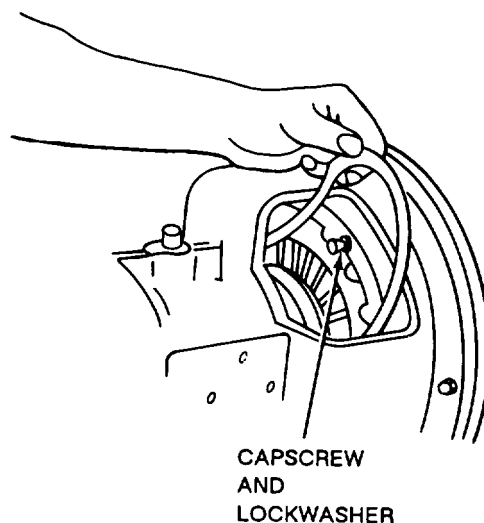

TA222983

**Figure 4-120. Alining Drive Ring.**

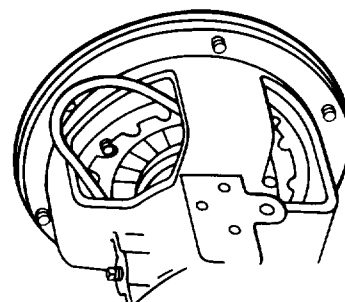

TA222984

**Figure 4-121. Checking Belt and Alternator Alinement.**

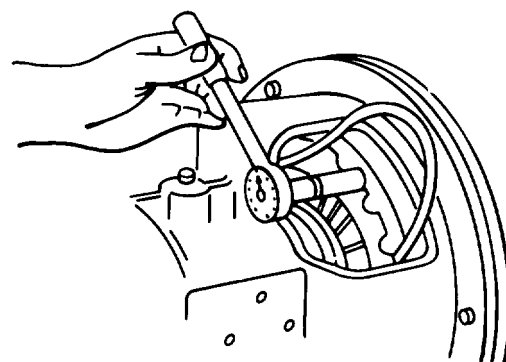

TA222985

**Figure 4-122. Torquing Drive Ring Capscrews.**

**4-79. Starter Motor**

*a. Test, On Equipment (Fig. 4-123).*

(1) Make sure batteries are fully charged and that all battery and starter cables are serviceable and properly installed.

(2) Turn engine switch (2, fig. 2-9) to RUN.

(3) Connect voltmeter as shown in figure 4-123, Test A. Turn starter switch (4, fig. 4-9) to START. A voltage reading (12V) indicates circuits leading to starter are okay.

(4) Connect a voltmeter as shown in figure 4-123, Test B. Turn starter switch (4, fig. 2-9) to START.

(a) If no voltage is indicated, solenoid is defective. Replace solenoid (para 4-80).

(b) If voltage is indicated, (12V) but starter does not turn, starter is defective. Replace starter.

*b. Removal (Fig. 4-124).*

**WARNING**

**When performing electrical maintenance, ALWAYS disconnect intervehicular electrical cable from semitrailer, and negative battery cables at batteries. Failure to follow this warning may create a spark and explosion, resulting in serious injury or death to personnel.**

(1) Remove negative battery cable from battery (fig. 4-37).

(2) Starter removal is done from underneath the vehicle on the left side of the engine.

(3) Remove starter solenoid protective bracket (1) by removing two retaining capscrews (2) and washers (3). Remove five capscrews (4) from engine air shutter. After these screws are removed, the engine air shutter can be raised to get at top retaining bolt on starter.

(4) Remove hot lead No. 6 from large bottom pole of solenoid and lead No. 74 from small pole on rear side of solenoid.

(5) Remove capscrew (5), washer (6), capscrew (7), external tooth lockwasher (8), and nut (9) from starter rear support bracket (10). Remove rear starter bracket.

(6) Raise engine shutter (fig. 4-124) so you can get at top retaining bolt on starter. Remove top capscrew (11) and washer (12) using a 3/8-inch drive set, long extension, universal joint, and a 9/16-inch universal socket. Remove bottom capscrew (13) and washer (14), then remove starter (15).

*c. Installation.*

**WARNING**

**When performing electrical maintenance, ALWAYS disconnect intervehicular electrical cable on semitrailer, and negative battery cables at batteries. Failure to follow this warning may create a spark and explosion, resulting in serious injury or death to personnel.**

(1) Before installing starter motor, check the pinion clearance (fig. 4-124). Proper clearance is important to ensure that starter engages.

(a) Press on solenoid core to shift the pinion into full mesh position, then measure the clearance between the pinion and pinion stop.

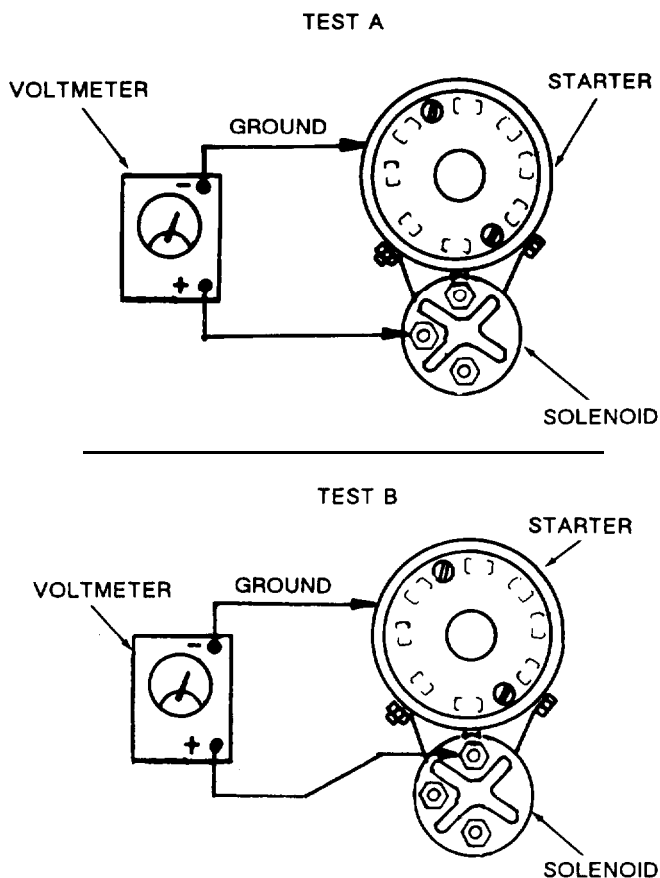

TA099853

**Figure 4-123. Testing Engine Starter.**

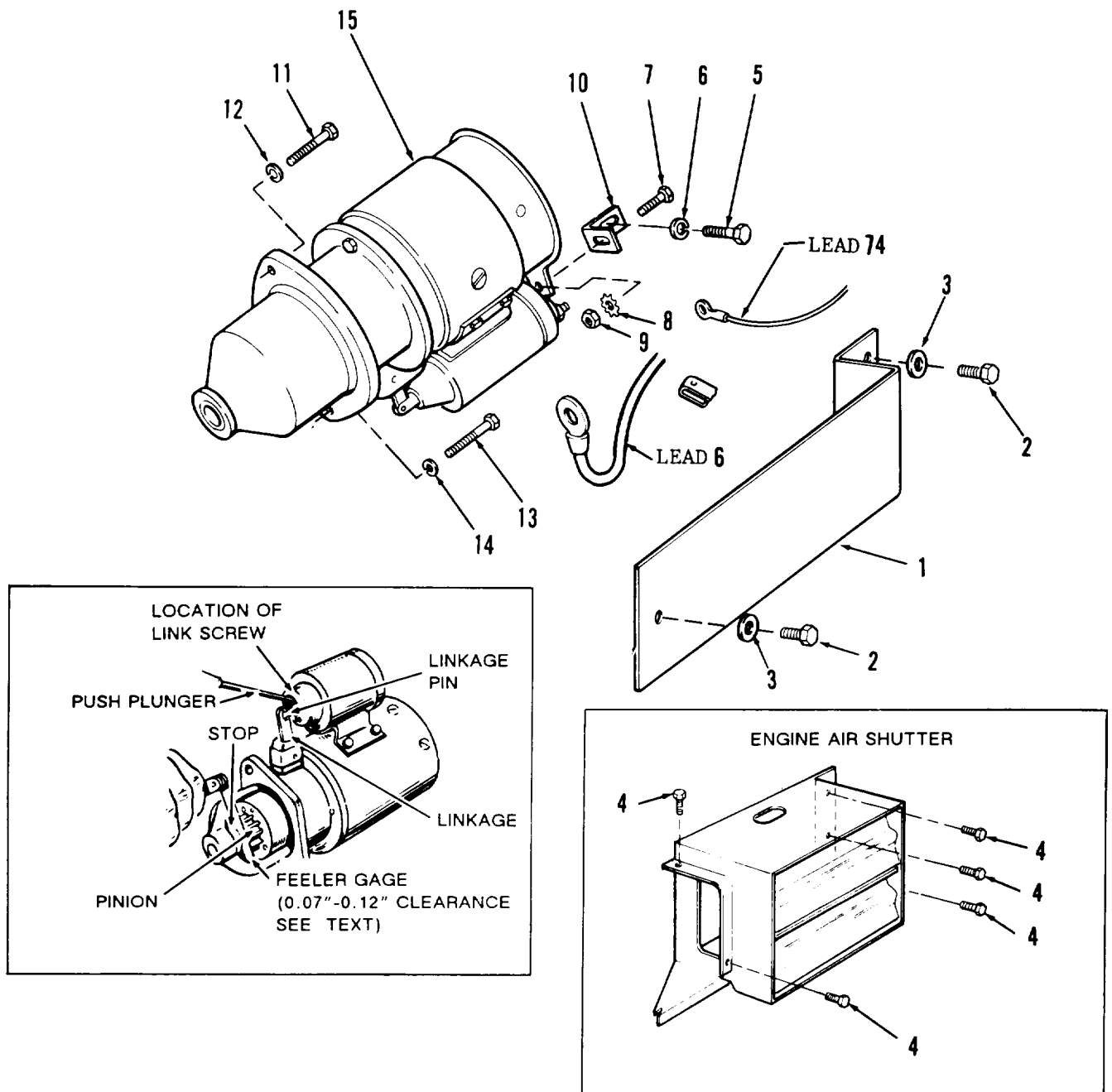

- |                                |                     |
|--------------------------------|---------------------|
| 1. Solenoid protective bracket | 9. Nut              |
| 2. Capscrew (2)                | 10. Starter bracket |
| 3. Washer (2)                  | 11. Capscrew        |
| 4. Capscrew (5)                | 12. Washer          |
| 5. Capscrew                    | 13. Capscrew        |
| 6. Washer                      | 14. Washer          |
| 7. Capscrew                    | 15. Starter         |
| 8. External tooth lockwasher   |                     |

Figure 4-124. Starter Removal.

TA099854

(b) The clearance should be between 0.070-inch and 0.120-inch (as near to 0.070-inch as possible).

(c) Adjust the link screw on the end of the solenoid plunger for proper clearance.

(2) Raise engine air shutter and position the starter motor and shield on engine. Install top retaining capscrew (11) and washer (12) on starter. Using a 3/8-inch drive set, long extension, universal joint, and a 9/16-inch universal socket, install bottom starter capscrew (13) and washer (14).

(3) Secure starter support bracket to starter using capscrew (7), washer (8), and nut (9). Do not tighten.

(4) Using capscrew (5) and washer (6) secure starter support bracket to engine. Tighten capscrew (7), washer (8), and nut (9).

(5) Attach leads No. 74 and No. 6 to starter solenoid.

(6) Replace the five capscrews (4) on engine air shutter.

(7) Connect negative battery cable to battery (fig. 4-37).

#### 4-80. Starter Solenoid

### **WARNING**

**When performing electrical maintenance, ALWAYS disconnect intervehicular electrical cable from semitrailer, and negative battery cables at batteries. Failure to follow this warning may create a spark and explosion, resulting in serious injury or death to personnel.**

#### *a. Removal.*

(1) Remove negative battery cable from battery (fig. 4-37).

(2) Starter solenoid removal must be done from underneath the vehicle on the left side of the engine.

(3) Remove starter solenoid protective bracket (1) by removing the two retaining capscrews (2) and washers (3).

(4) Remove hot lead No. 6 from large bottom pole of solenoid and lead No. 74 from small pole.

(5) Remove linkage pin which connects solenoid shaft to linkage (fig. 4-124).

(6) Remove two screws that fasten solenoid to starter motor. Remove solenoid.

#### *b. Installation.*

(1) Position starter solenoid on starter motor and fasten with two screws.

(2) Connect starter linkage to solenoid using linkage pin.

(3) Attach hot lead No. 6 to large bottom pole of solenoid and lead No. 74 to small pole.

(4) Replace starter solenoid protective shield. Fasten with two capscrews and washers.

(5) Connect negative battery cable to battery (fig. 4-37).

#### 4-81. Buss Bar

### **WARNING**

**When performing electrical maintenance, ALWAYS disconnect intervehicular electrical cable from semitrailer, and negative battery cables at batteries. Failure to follow this warning may create a spark and explosion, resulting in serious injury or death to personnel.**

#### *a. Replacing Buss Fuse (Fig. 4-125).*

(1) Disconnect negative battery cable from battery (fig. 4-37).

(2) Remove buss bar cover (fig. 4-125) by removing two capscrews and nuts.

(3) Remove buss bar fuse from its clips.

(4) Install new fuse between clips.

(5) Replace buss bar cover. Attach to firewall with two capscrews and nuts.

(6) Reconnect negative battery cable to battery (fig. 4-37).

#### *b. Removal.*

(1) Perform steps (1) through (3) of paragraph *a*.

(2) Disconnect all electrical leads from buss bar.

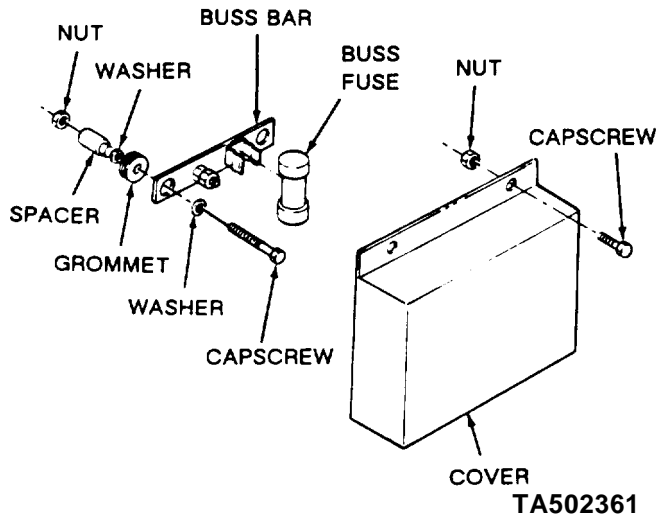

**Figure 4-125. Removal of Buss Bar.**

(3) Remove two cap screws (fig. 4-125), washers, and nuts securing each buss bar to firewall.

(4) Remove buss bar assembly, washers, and spacers.

*c. Installation.*

(1) Install washer on each cap screw (fig. 4-125).

(2) Insert cap screw through grommets on buss bar.

(3) Slide a washer and spacer onto each cap screw and insert through fire wall.

(4) Attach each buss bar to firewall with nuts.

(5) Connect all electrical leads to buss bar.

(6) Install fuse into fuse clips.

(7) Replace buss bar cover. Secure with two cap screws, washers, and nuts.

(8) Reconnect negative battery cable to battery (fig. 4-37).

**4-82. Intake Manifold Assembly (Fig. 4-126)**

*a. Inspection, On Equipment (Fig. 4-126).*

(1) Remove engine panel door (fig. 4-101). Start engine (para 2-10).

(2) While engine is operating, check for leaks; especially at gaskets (14) between intake manifold (13) and cylinder head, gasket (11) between air cleaner adapter and manifold, and gasket (5) between the manifold heater mounting plate (4) and the manifold.

(3) Drop oil from an oilcan or hold a piece of thin paper on point suspected of leaking. If leak exists, oil will be sucked in or paper will be sucked against leaking area.

(4) Shut off engine (para 2-10) and replace engine panel door.

*b. Removal.*

(1) Remove air cleaner hose from manifold and manifold heaters (para 4-20).

(2) Remove two screws (1), lockwashers (2), and insulator sleeves (3). Remove heater mounting plate (4) and gasket (5).

(3) Remove cap screw (6), washer (7), cap screw (8), washer (9), air cleaner adapter (10), and gasket (11).

(4) Remove four nuts (12), then remove intake manifold (13) and two gaskets (14).

(5) Clean away any gasket material stuck to manifold, heater mounting plate, air cleaner adapter, and cylinder heads. Discard gaskets and insulator sleeves.

*c. Repair.* Remove manifold as given above and replace gaskets if leaks occur.

*d. Installation.*

(1) Install intake manifold (13) and new gaskets (14) to cylinder heads and secure with four nuts (12). Tighten nuts to 13-15 lb.-ft.

(2) Install air cleaner adapter (10) and new gasket (11) to manifold, and secure with cap screws (6 and 8) and washers (7 and 9).

(3) Install heater mounting plate (4) and new gasket (5) to manifold, and secure with two new insulator sleeves (3), two screws (1), and lockwashers (2).

(4) Install manifold heaters (para 4-20).

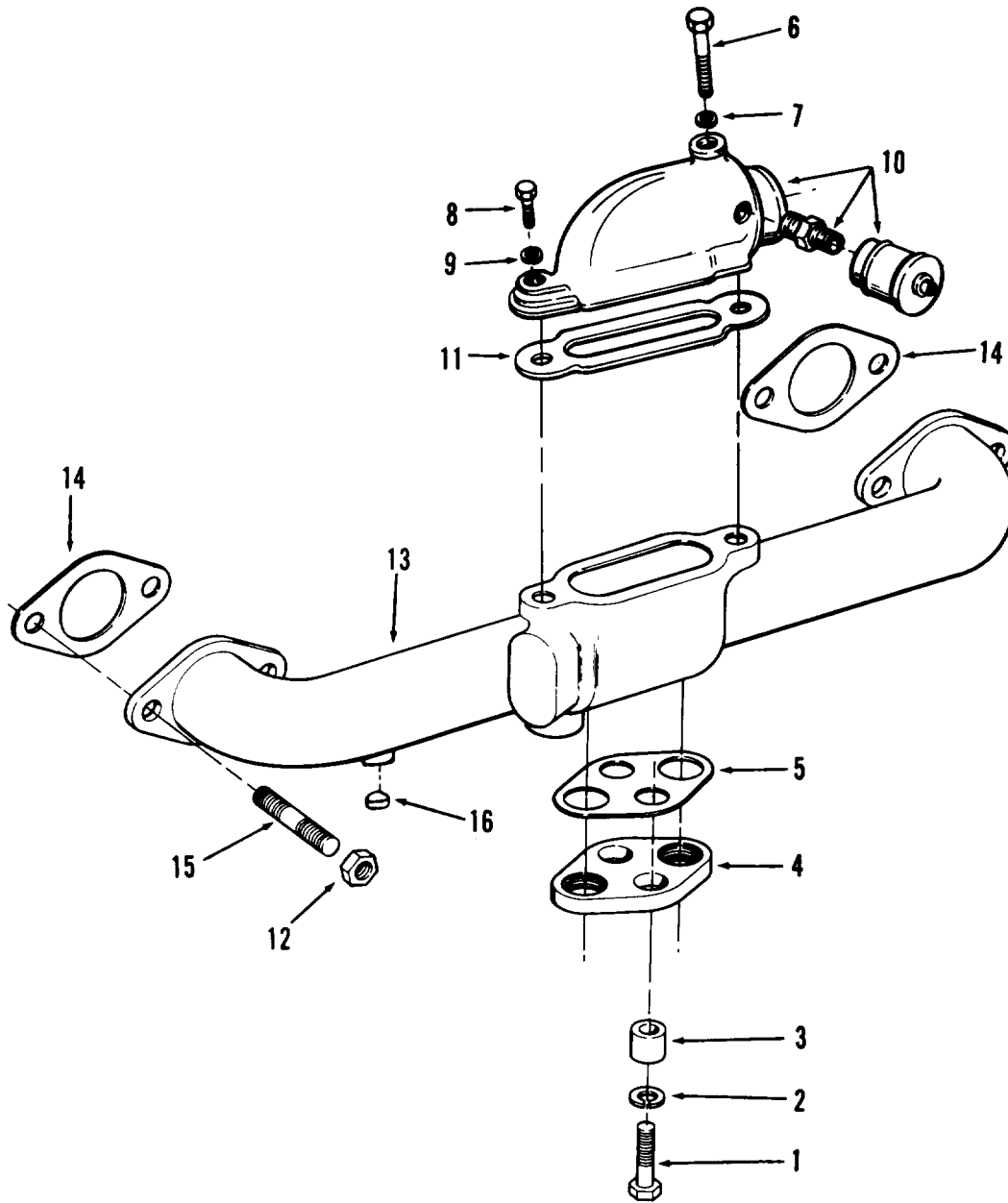

- |                          |                         |
|--------------------------|-------------------------|
| 1. Screw (2)             | 9. Washer               |
| 2. Lockwasher (2)        | 10. Air cleaner adapter |
| 3. Insulator sleeve (2)  | 11. Gasket              |
| 4. Heater mounting plate | 12. Nut (4)             |
| 5. Gasket                | 13. Intake manifold     |
| 6. Capscrew              | 14. Gasket (2)          |
| 7. Washer                | 15. Stud (4)            |
| 8. Capscrew              | 16. Plug                |

**Figure 4-126. Intake Manifold.**

TA099856

**Section XVIII. MAINTENANCE OF FILTER/SEPARATOR AND SUMP COMPONENTS  
(M969, M969A1, M970, and M970A1)**

**4-83. Filter/Separator (Fig. 4-127)**

**WARNING**

**Read and observe all safety precautions listed in the Warning Summary before performing maintenance on filter/separator. Ensure that semitrailer is grounded to an approved (earth) ground and it is safe to proceed. Failure to follow this warning may cause a spark to ignite, resulting in serious injury or death to personnel.**

*a. Removal of Elements and Fuses.*

**NOTE**

**Be sure all valves are closed.**

(1) Place a suitable container under the manual drain valve N (fig. 4-127). Open valve N and remove any fluid from filter/separator. When thoroughly drained, close drain valve.

**NOTE**

**Note location of lead seal wires for installation.**

(2) Cut two lead seal wires at top and bottom of cover (4).

(3) Remove 12 nuts (1), bolts (2), and washers (3) that fasten cover (4) to mounting flange.

(4) Remove cover (4) by pulling straight out from flange.

(5) Remove gasket (5) and discard.

(6) Unscrew four wingnuts (6) and remove with washers (7 and 8).

(7) Remove retaining plate (9).

(8) Starting with lower canister assembly (nearest to service port), remove the support (10), and pull canister assembly (11) to the right until it drops down so it can be removed through the service port.

(9) Remove the four remaining canister assemblies in the same way; always remove lower canister assembly first.

(10) Disassemble canister assembly as follows:

(a) Pull adapter (13) from canister (12).

(b) Remove fuses (15) from canister and discard.

(c) Remove fuse clip (14).

(d) Remove two gaskets (16 and 17) from adapter. Gasket (17) might remain in filter/separator; remove it.

(11) Unscrew plastic retainers (18) from the element (19) guide pipes.

(12) Slide elements (19) off guide pipes.

*b. Installation of Elements and Fuses.*

(1) Start installation of elements (19, fig. 4-127) on the guide pipes farthest from the service port. Coat O-ring of element with petrolatum (item 23, Appendix E). Install elements on guide pipes.

(2) Install plastic retainers (18) and hand tighten only. Do not overtighten.

(3) Reassemble canister assembly:

(a) Install two new gaskets (16 and 17) in adapter (13). Gasket (16) will not go in flat.

(b) Place adapter on bench and insert three new Go-No-Go fuses (15). Push fuses all the way down into holes.

(c) Place clip (14) on top of fuses.

(d) Slide canister (12) over fuses (15) and push into adapter.

(4) Put a canister assembly through the service port with adapter end down toward bottom of tank. Turn adapter end to the left and lift canister into position on the upper guide rods farthest from service port. Slide canister to the left until it fits into the outlet hole.

(5) Raise end of canister assembly and install support (10) near end of canister.

(6) Install next canister on top guide rods, followed by lower row starting with the farthest installation and working toward service port.

**NOTE**

**Hand tighten wingnuts. DO NOT use a wrench.**

(7) Replace canister retainer plate (9) and secure with four wingnuts (6) and washers (7 and 8).

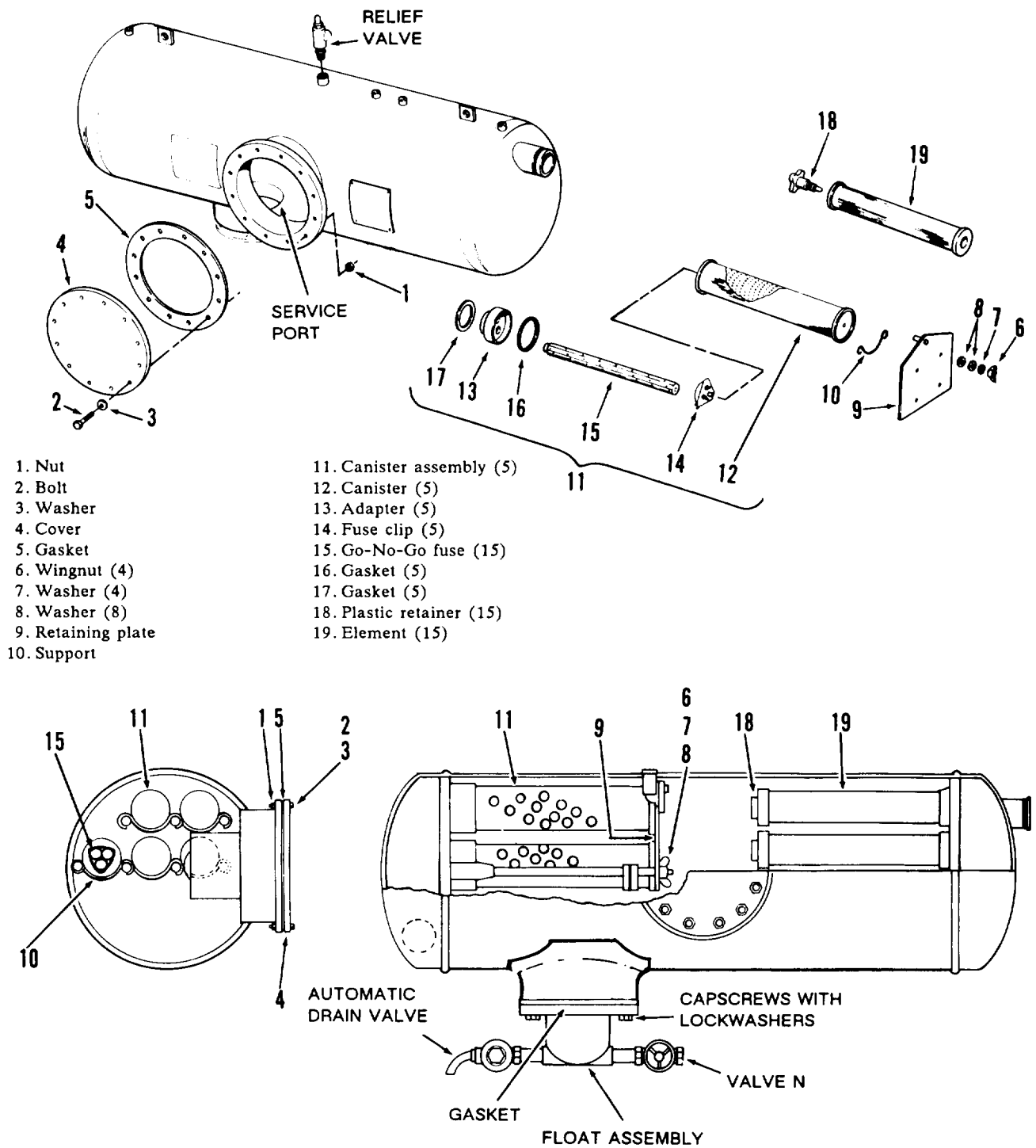

Figure 4-127. Exploded View of Filter/Separator.

TA502362



(8) Install new gasket (5).

(9) Replace cover (4). Secure with twelve bolts (2), washers (3), and nuts (1). Ensure that four bolts with holes in shaft are installed where lead seal wires will be installed.

(10) Install one lead seal wire through holes in top pair of bolts (2) and one through holes in bottom pair. Put wires through seals and crimp, using tool, Lead Seal Press, NSN 5120-00-224-7592. Trim excess wire.

**4-84. Sump Components**

**WARNING**

**Read and observe all safety precautions listed in the Warning Summary before performing maintenance on sump components. Ensure that semitrailer is grounded to an approved (earth) ground and it is safe to proceed. Failure to follow this warning may cause a spark to ignite, resulting in serious injury or death to personnel.**

a. *Automatic Drain Valve and Float Assembly.*

(1) *Removal.*

(a) Close valve M.

(b) Place a suitable container under the manual drain valve N (fig. 4-127). Open valve N and remove air fluid from filter/separator. When thoroughly drained, close valve N.

**NOTE**

**DO NOT disconnect the tubes connecting the float assembly to the automatic drain valve.**

(c) Disconnect the tube coming from top of filter/separator at the float assembly. Only the M970 and M970A1 have a second tube to be disconnected.

(d) Remove the eight capscrews and washers that fasten the float assembly to the filter/separator. Remove float and automatic drain valve assembly.

(e) Remove and discard gasket.

(f) Remove manual drain valve from the assembly.

(2) *Installation.*

(a) Place a new gasket on flange of float assembly.

(b) Install float and automatic drain valve to filter/separator. Attach with eight capscrews and washers. Tighten securely.

(c) Connect the tube line(s) to the float assembly.

b. *Replacement of Manual Drain Valve.*

(1) Close valve M.

(2) Place a suitable container under the manual drain valve N (fig. 4-127). Open valve N and remove all fluid from filter/separator.

(3) Unscrew manual drain valve from float assembly. Be sure nipple does not come off with drain valve.

**NOTE**

**Be sure manual drain valve is closed.**

(4) Screw manual drain valve tightly onto nipple of float assembly.

**Section XIX. MAINTENANCE OF DISPENSING EQUIPMENT**

**4-85. General**

**WARNING**

**Read and observe all safety precautions listed in the Warning Summary before performing maintenance on dispensing equip-**

**ment. Ensure that semitrailer is grounded to an approved (earth) ground and it is safe to proceed. Failure to follow this warning may cause a spark to ignite, resulting in serious injury or death to personnel.**

a. Read and observe all safety precautions in the Warning Summary.

b. Consider the location of the unit to be serviced, and drain the affected valves and piping.

c. Consider the size and weight of the unit to be removed and provide support.

d. Loosen or remove any item necessary to allow removal of the unit. In some instances when removing valves, piping may have to be loosened at different places to make it easy to remove valve and gaskets.

e. When replacing O-rings, coat with petrolatum (item 23, Appendix E) to facilitate installation.

f. Coat all male threaded pipe fittings with antiseize tape (item 27, Appendix E) before installation.

g. Following the replacement of any unit, test for leaks and correct if leaks are evident.

h. When installing split couplings and gaskets, follow procedure below:

(1) Lubricate complete gasket with petrolatum (item 23, Appendix E).

(2) Slide gasket onto one pipe end. Ensure that gasket lip does not overhang pipe end.

(3) Align and bring the two pipe ends together and slide gasket into position centered between the grooves on each pipe end. No portion of gasket should extend into groove on either pipe (fig. 4-128).

(4) Assemble the coupling, being sure edges of coupling drop securely into grooves. Squeeze housing tight with hands to further center the gasket and seat the housing.

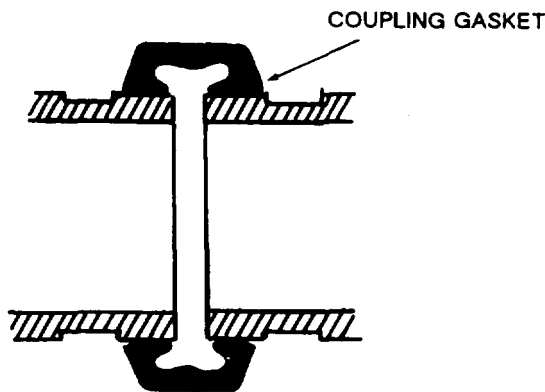

TA502383

Figure 4-128. Installing Coupling Gasket.

**CAUTION**

**Uneven tightening of nuts may cause gasket to pinch.**

(5) Install coupling bolts and tighten nuts finger tight. Tighten the nuts uniformly until coupling halves are firmly together—metal-to-metal. Tighten nuts to torque specified.

**4-86. Valves**

a. *General.* Refer to the General Instructions in paragraph 4-85.

b. *Gate Valves (Fig. 4-129).*

(1) *Removal.* Remove connecting nuts, washers, and bolts, or two nuts and bolts, from couplings. Remove couplings. Remove valve and gaskets.

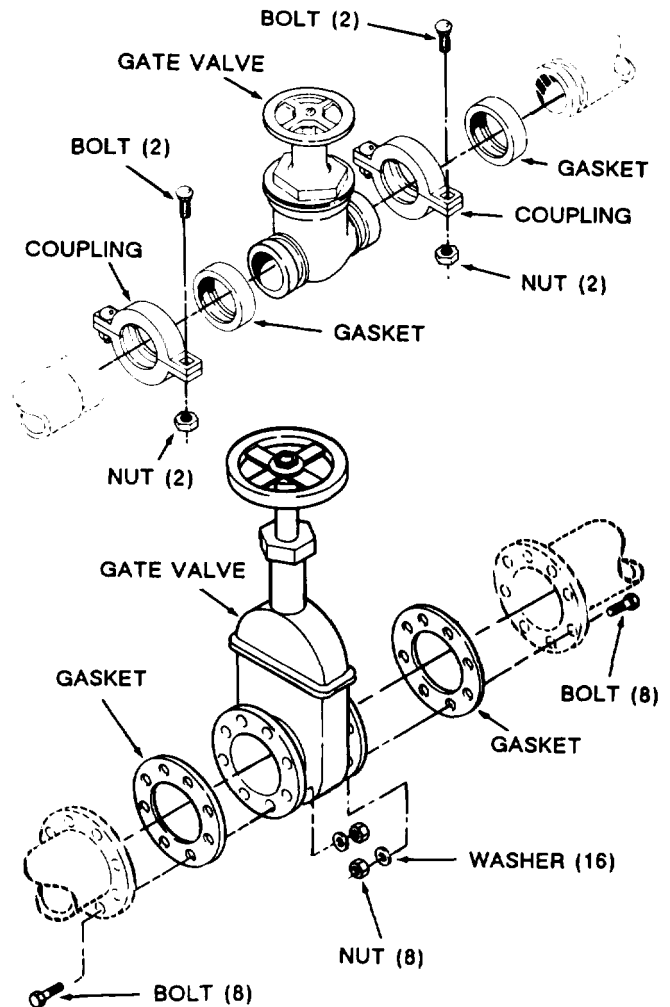

TA099859

Figure 4-129. Typical Gate Valves and Couplings.

**WARNING**

Dry cleaning solvent P-D-680 is toxic and flammable. Always wear protective goggles and gloves, and use only in a well-ventilated area. Avoid contact with skin, eyes, and clothes, and DO NOT breathe vapors. DO NOT use near open flame or excessive heat. The solvent's flash point is 100°F-138°F (38°C-59°C). If you become dizzy while using cleaning solvent, immediately get fresh air and medical help. If solvent contacts eyes, immediately wash your eyes with water and get medical aid.

(2) *Cleaning and Inspection.* Clean with dry cleaning solvent (item 11, Appendix E). Inspect gaskets and valves.

(3) *Installation.* Install valves and new gaskets and attach with bolts, washers, and nuts, or split couplings (para 4-85). Tighten coupling nuts to 95-105 lb.-ft. Tighten valve mounting bolts to 25-35 lb.-ft.

*c. Butterfly Valve (fig. 4-130).*

(1) *Removal.* Remove sixteen nuts, sixteen washers, and eight studs. Remove valve.

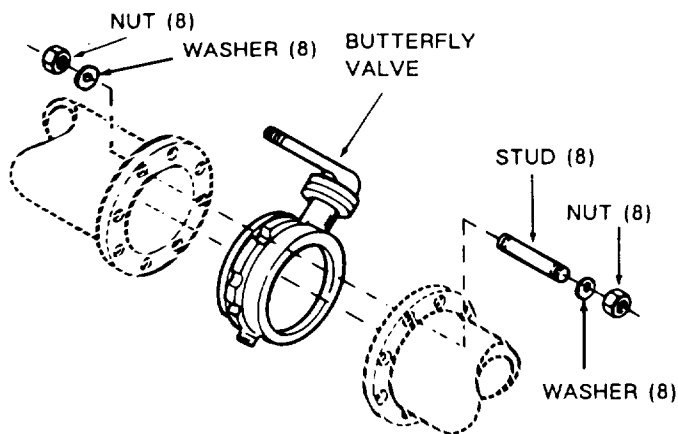

TA502363

**Figure 4-130. Typical Butterfly Valve.**

**WARNING**

Dry cleaning solvent P-D-680 is toxic and flammable. Always wear protective goggles and gloves, and use only in a well-ventilated area. Avoid contact with skin, eyes, and clothes, and DO NOT breathe vapors. DO

NOT use near open flame or excessive heat. The solvent's flash point is 100°F-138°F (38°C-59°C). If you become dizzy while using cleaning solvent, immediately get fresh air and medical help. If solvent contacts eyes, immediately wash your eyes with water and get medical aid.

(2) *Cleaning and Inspection.* Clean with cleaning solvent (item 11, Appendix E). Inspect sealing surfaces of valve for physical damage.

(3) *Installation.* Install valve and attach with sixteen washers, sixteen nuts, and eight studs. Tighten nuts securely.

*d. Angle Valve and Check Valve (M969, M969A1, M970, and M970A1) (Fig. 4-131).*

(1) *Removal.*

(a) Remove coupling at rear of check valve.

(b) Remove four capscrews, washers, and nuts from bottom of angle valve.

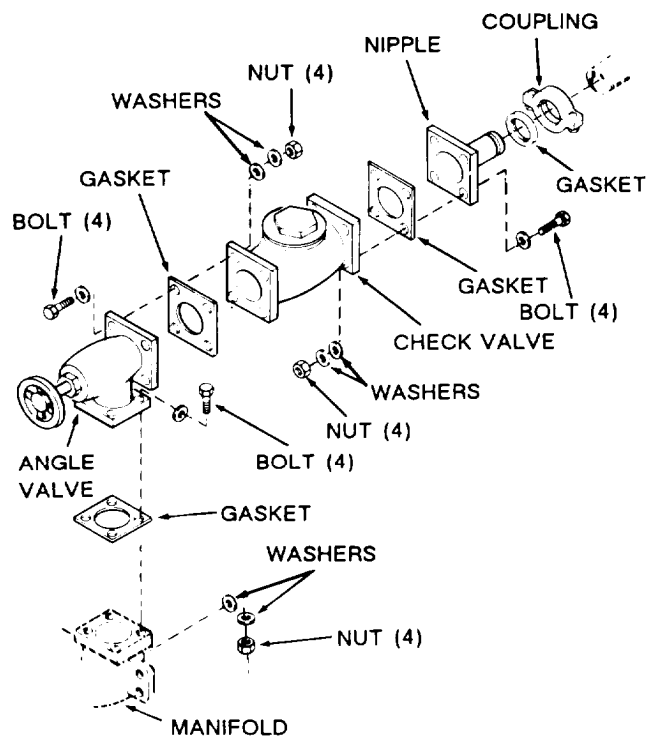

TA502364

**Figure 4-131. Angle Valve and Check Valve (M969, M969A1, M970, and M970A1).**

(c) Remove angle valve and check valve as a complete assembly.

(d) Separate check valve and angle valve on a bench by removing four capscrews, washers, and nuts.

**WARNING**

**Dry cleaning solvent P-D-680 is toxic and flammable. Always wear protective goggles and gloves, and use only in a well-ventilated area. Avoid contact with skin, eyes, and clothes, and DO NOT breathe vapors. DO NOT use near open flame or excessive heat. The solvent's flash point is 100°F-138°F (38°C-59°C). If you become dizzy while using cleaning solvent, immediately get fresh air and medical help. If solvent contacts eyes, immediately wash your eyes with water and get medical aid.**

(2) *Cleaning and Inspection.* Clean with dry cleaning solvent (item 11, Appendix E). Inspect gaskets and valves.

(3) *Installation.*

(a) Assemble angle valve, new gasket, and check valve assembly by securing both valves together with four capscrews, washers, and nuts.

(b) Position angle valve and check valve between manifold and pipe. Install new gasket, four capscrews, washers, and nuts to secure angle valve to manifold. Do not tighten capscrews.

(c) Install coupling and gasket (para 4-85h). Tighten coupling nuts to 57-63 lb.-ft.

(d) Tighten capscrews securing angle valve to manifold to 25-35 lb.-ft.

e. *Check Valve (M967, M967A1, M969, and M969A1) (Fig. 4-132).*

(1) *Removal.* Remove sixteen capscrews, washers, and nuts. Remove valve and gaskets.

**WARNING**

**Dry cleaning solvent P-D-680 is toxic and flammable. Always wear protective goggles and gloves, and use only in a well-ventilated area. Avoid contact with skin, eyes, and clothes, and DO NOT breathe vapors. DO NOT use near open flame or excessive heat.**

**The solvent's flash point is 100°F-138°F (38°C-59°C). If you become dizzy while using cleaning solvent, immediately get fresh air and medical help. If solvent contacts eyes, immediately wash your eyes with water and get medical aid.**

(2) *Cleaning and Inspection.* Clean with dry cleaning solvent (item 11, Appendix E). Inspect gaskets and valves.

(3) *Installation.* Install valve and new gaskets with sixteen capscrews, washers, and nuts. Tighten nuts to 25-35 lb.-ft.

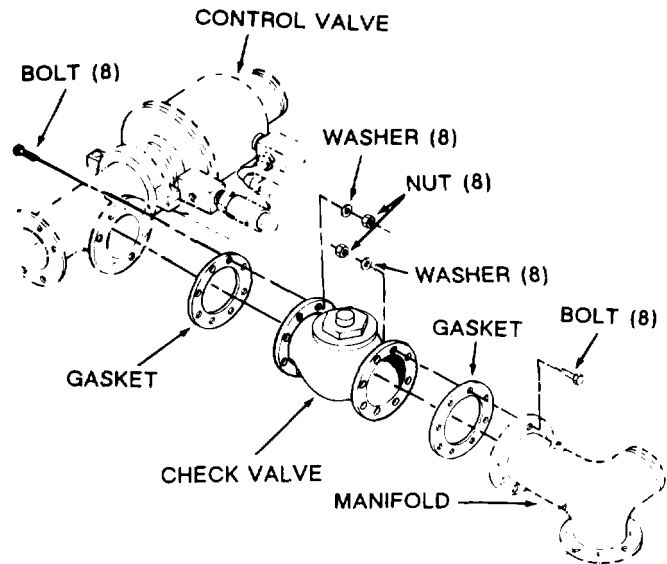

TA099862  
**Figure 4-132. Check Valve (M967, M967A1, M969, and M969A1).**

f. *4-Inch Control Valve (Bottom Loading) (Figs. 4-134 and 4-135).*

(1) *Adjustment (to ensure that fuel shut-off closes).*

(a) Start with empty tank.

(b) Refer to flow diagram for either filtered self-load (fig. 2-34) or non-filtered bottom load (fig. 2-22).

(c) Install a 0-60 psi pressure gage in the 3/8-inch NPT port on underwing nozzle (fig. 4-133) for filtered self-load or non-filtered bottom load.

(d) Connect underwing nozzle (for self-load) or storage facility hose to the bottom load adapter (figs. 4-147 through 4-149).

(e) Remove plastic plug (fig. 4-134) from needle valve.

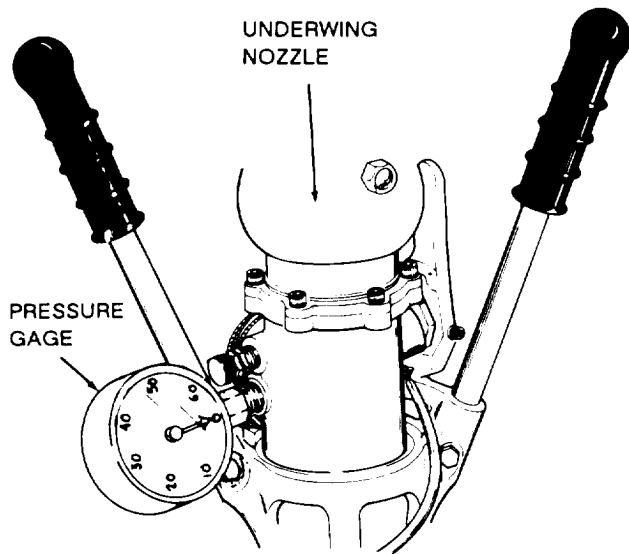

TA099863

Figure 4-133. Installation of Pressure Gage.

(f) Using a 4-inch long screwdriver (fig. 4-134), turn screwdriver counterclockwise 8-10 full turns to open needle valve on 4-inch control valve.

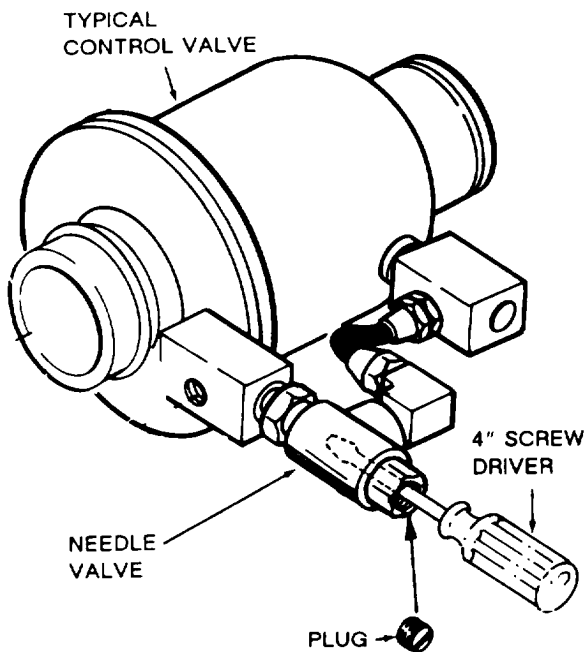

TA099864

Figure 4-134. Adjustment of Needle Valve.

(g) Start engine (para 2-10) and begin loading (para 2-14a for self-load and para 2-13b for non-filtered bottom load).

**WARNING**

**DO NOT close needle valve completely. This will prevent 4-inch control valve from closing at anytime during bottom load operations.**

(h) Close (clockwise) needle valve in 1/4-turn increments. Observe change in pressure reading at each step, until there is no change in pressure.

(i) At this point, open precheck valve D (fig. 2-26).

LOCATED BEHIND PIPING CONTROL ASSEMBLY

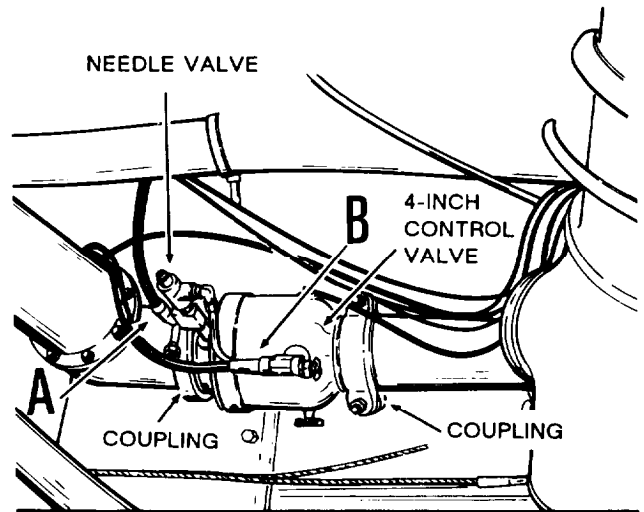

TA099866

Figure 4-135. Location of 4-Inch Control Valve.

(j) Sound of control valve starting to close should be heard in approximately 30 seconds. Full shut off should be obtained in an additional 3-5 seconds.

(k) If full shut off is not obtained (sound of liquid flow or whistle are indications) open (counterclockwise) needle valve in 1/4-turn increments until it does. Then close precheck valve, allowing flow to resume.

**NOTE**

- Closing needle valve increases closing time.
- Opening needle valve decreases closing time.

(1) Repeat steps (h), (i), and (j), changing needle valve setting in 1/4-turn or less increments until the 3-5 second closing rate is obtained.

(m) Shut off engine (para 2-10).

(n) Replace plastic plug in needle valve.

(o) Remove gage from underwing nozzle and stow nozzle.

(2) Removal.

(a) Disconnect the two nylon tubes from the 4-inch control valve at points A and B (fig. 4-135).

(b) Remove the two nuts and bolts from the two couplings (fig. 4-135) and remove the couplings. Slide gaskets onto mating pipes and remove the control valve assembly.

(c) Place control valve assembly on a clean surface and remove tube elbow (1, fig. 4-136) from control valve.

(d) Unscrew tee (3) from control valve and remove tee (3), drain cock (2), and tube fitting (4) as an assembly.

(e) Unscrew drain cock (5) from control valve.

(3) Installation.

(a) Remove drain plug from new control valve and install drain cock (5) (fig. 4-136).

(b) Install drain cock (2), tee (3), and tube fitting (4) assembly onto control valve.

(c) Install tube elbow (1) onto control valve.

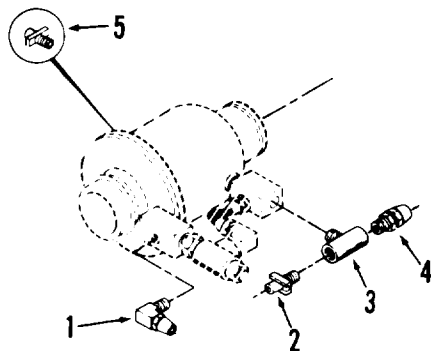

- |               |                 |
|---------------|-----------------|
| 1. Tube elbow | 4. Tube fitting |
| 2. Drain cock | 5. Drain cock   |
| 3. Tee        |                 |

TA099867

**Figure 4-136. Removal of Fittings From 4-Inch Control Valve.**

(d) Position control valve, and slide coupling gaskets over valve ends (para 4-85). Install couplings.

(e) Connect the two nylon tubes (fig. 4-135) at A and B.

g. 3-inch Control Valve (Deadman Valve) (M970 and M970A1).

(1) Adjustment.

(a) Locate needle valve (fig. 4-137) and remove plastic plug.

(b) Using a 4-inch-long screwdriver, close needle valve (fig. 4-134) completely by turning adjusting screw clockwise.

(c) When closed, turn adjusting screw five turns counterclockwise to adjust valve to proper setting.

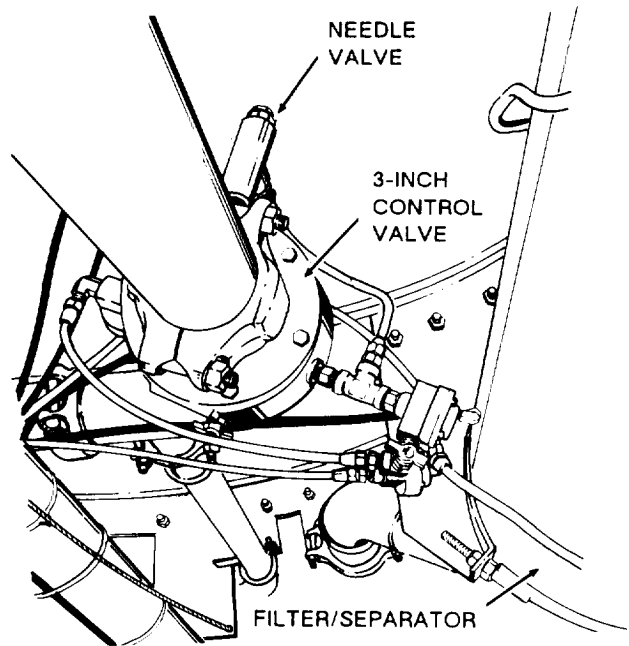

TA099868

**Figure 4-137. Location of Needle Valve.**

(2) Removal (Fig. 4-138).

(a) Disconnect and tag the five nylon tubes from the control valve at points A through E.

(b) Loosen fitting (1) and elbow (2), and remove copper tubing (3).

(c) Remove two nuts from each of two couplings (4 and 5) and remove the couplings.

(d) Slide the coupling gaskets onto the control valve and remove the control valve assembly.

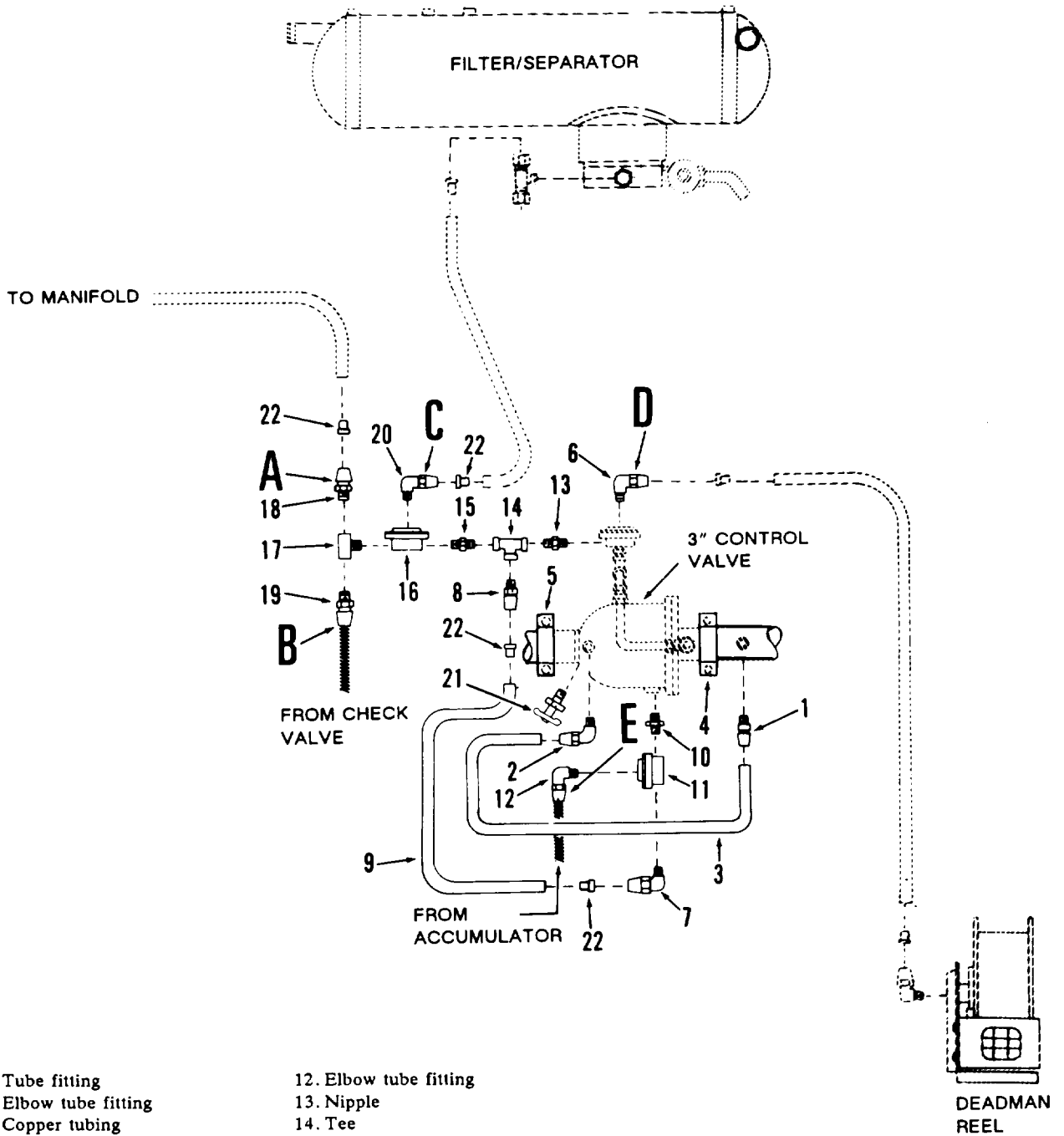

- |                       |                        |
|-----------------------|------------------------|
| 1. Tube fitting       | 12. Elbow tube fitting |
| 2. Elbow tube fitting | 13. Nipple             |
| 3. Copper tubing      | 14. Tee                |
| 4. Coupling           | 15. Nipple             |
| 5. Coupling           | 16. Valve              |
| 6. Elbow tube fitting | 17. Tee                |
| 7. Elbow tube fitting | 18. Tube fitting       |
| 8. Tube fitting       | 19. Tube fitting       |
| 9. Nylon tubing       | 20. Elbow tube fitting |
| 10. Nipple            | 21. Drain valve        |
| 11. Valve             | 22. Inserts (4)        |

TA502365

Figure 4-138. 3-Inch Control Valve Installation (M970 and M970A1).

(e) Place the control valve assembly on a clean surface and remove elbow (6) from the control valve.

(f) Remove coupling gaskets.

(g) Loosen fittings (7) and (8) and remove tube (9).

(h) Unscrew nipple (10). Remove valve (11), and elbows (7 and 12) as an assembly.

(i) Unscrew nipple (13). Remove tee (14), nipple (15), valve (16), tee (17), and hose fittings (8 and 18 through 20) as an assembly.

(j) Unscrew elbow (2) and drain valve (21).

(3) *Installation (Fig. 4-138).*

(a) Remove drain plug from new control valve, and install drain cock (12).

(b) Install items (8) and (13 through 20) onto the control valve as an assembly.

(c) Install items (7) and (10 through 12) onto control valve as an assembly.

(d) Replace line (9) and inserts (22) between fittings (7) and (8). Tighten fittings.

(e) Slide coupling gaskets over control valve tubes.

(f) Position control valve between tubes and install couplings (para 4-85). Tighten nuts to 95-105 lb.-ft.

(g) Replace elbow (2) and connect copper tubing (3) between elbow (2) and fitting (1).

(h) Connect the five nylon tubes to the control valve at points A through E.

*h. Emergency Valve (Fig. 4-139).*

(1) *Removal.*

(a) Loosen, but do not remove, two nuts from U-bolt (fig. 4-139) on emergency valve lever and disconnect emergency valve cable.

**CAUTION**

**Support large outlet tube before removing coupling.**

(b) Remove two nuts and bolts from coupling and remove coupling. Slide gasket onto emergency valve.

(c) Remove eight nuts from studs securing emergency valve to sump on tank.

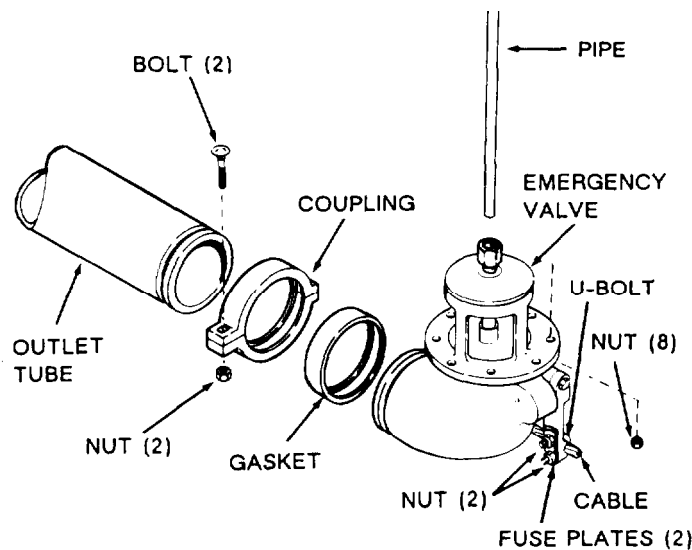

**Figure 4-139. Emergency Valve.**

TA502366



(d) Remove emergency valve, pipe, adapter, and gasket from tank sump.

(e) Remove coupling gasket from emergency valve.

(2) *Cleaning and Inspection.*

**WARNING**

**Dry cleaning solvent P-D-680 is toxic and flammable. Always wear protective goggles and gloves, and use only in a well-ventilated area. Avoid contact with skin, eyes, and clothes, and DO NOT breathe vapors. DO NOT use near open flame or excessive heat. The solvent's flash point is 100°F-138°F (38°C-59°C). If you become dizzy while using cleaning solvent, immediately get fresh air and medical help. If solvent contacts eyes, immediately wash your eyes with water and get medical aid.**

(a) Clean valve with dry cleaning solvent (item 11, Appendix E).

(b) Replace gaskets. Inspect valve for cracks, distortion, and wear.

(3) *Installation.*

(a) Slide coupling gasket onto emergency valve.

**NOTE**

**Be sure pipe is engaged with vent.**

(b) Install valve, pipe, adapter, and gasket to tank sump and attach eight nuts. Tighten nuts to 50-75 lb.-ft.

(c) Slide gasket over joint and attach coupling (para 4-85). Tighten nuts to 104-116 lb.-ft.

(d) Reconnect emergency valve cable to the emergency valve lever. Tighten the two U-bolt nuts. Check for proper operation of emergency valve and cable adjustment (para 4-52).

*Pump Bypass Valve (M970 and M970A1)*  
(Fig. 4-140).

(1) *Adjustment.* The pump bypass valve is preset at 45 psi. No further adjustment is necessary.

(2) *Removal.* Remove two nuts and bolts from both couplings and remove couplings. Slide gaskets back and remove valve. Unscrew the two nipples.

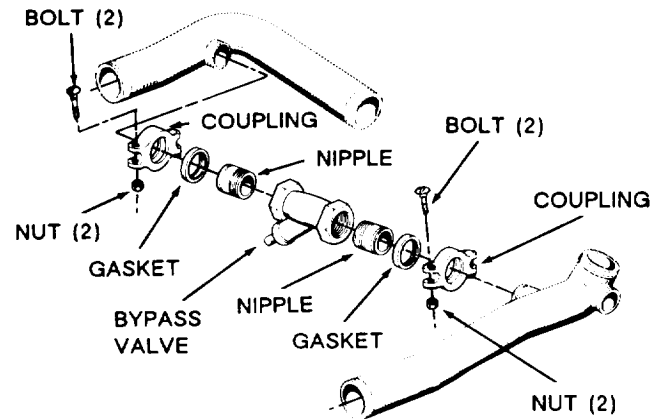

TA099870

Figure 4-140. Pump Bypass Valve (M970 and M970A1).

**WARNING**

**Dry cleaning solvent P-D-680 is toxic and flammable. Always wear protective goggles and gloves, and use only in a well-ventilated area. Avoid contact with skin, eyes, and clothes, and DO NOT breathe vapors. DO NOT use near open flame or excessive heat. The solvent's flash point is 100°F-138°F (38°C-59°C). If you become dizzy while using cleaning solvent, immediately get fresh air and medical help. If solvent contacts eyes, immediately wash your eyes with water and get medical aid.**

(3) *Cleaning and Inspection.* Clean with dry cleaning solvent (item 11, Appendix E). Inspect coupling gaskets, valve seat, and body.

(4) *Installation.* Screw nipples into valve and tighten with a pipe wrench. Slide flange coupling gaskets over nipples. Position valve and slide gaskets over joints (para 4-85). Attach split couplings. Tighten nuts to 95-105 lb.-ft.

**4-87. Piping Strainer (Fig. 4-141)**

a. *Service.*

**WARNING**

- **Dry cleaning solvent P-D-680 is toxic and flammable. Always wear protective goggles and gloves, and use only in a well-ventilated area. Avoid contact with skin, eyes, and clothes, and DO NOT breathe vapors. DO NOT use near open flame or excessive heat. The solvent's flash point is 100°F-138°F (38°C-59°C). If you become dizzy while using cleaning solvent, immediately get fresh air and medical help. If solvent contacts eyes, immediately wash your eyes with water and get medical aid.**
- **Compressed air used for drying or cleaning purposes must not exceed 30 psi (207 kPa). Wear protective clothing (goggles and gloves) and use caution to avoid injury to personnel.**

(1) Every three months (quarterly), remove strainer. Clean strainer and inside of tube with dry cleaning solvent (item 11, Appendix E). Use compressed air to remove any other sediment.

(2) Inspect strainer for deterioration. Replace strainer if it can no longer service the dispensing system.

b. *Removal.*

(1) Remove batteries to avoid deterioration from splashing fuel (para 4-23).

**NOTE**

**A suitable container must be provided to collect approximately 3 gallons of fluid that is in pump housing and pipe.**

(2) Remove the two nuts and bolts (fig. 4-141) from split flange coupling and remove coupling. Collect fluid in container.

(3) Remove coupling gasket, then pull strainer from tube.

(4) Dispose of fluid in accordance with local SOP.

c. *Installation.*

(1) Slide coupling gasket onto tube (para 4-85).

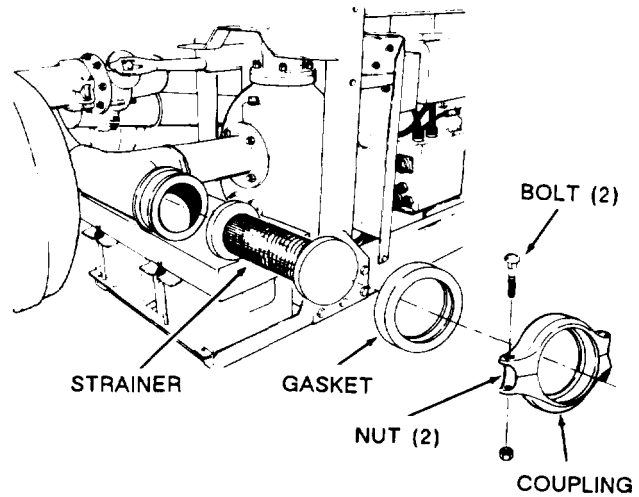

TA099871

**Figure 4-141. Piping Strainer.**

(2) Install strainer in tube, slide gasket over joint, and attach coupling. Tighten nuts to 104-116 lb.-ft.

(3) Install batteries (para 4-23).

**4-88. Recirculation Adapter (Fig. 4-1 42)**

a. *Replacement of Gasket.*

(1) Remove eight self-locking nuts (1).

(2) Remove adapter plate (2) and gasket (3).

(3) Install new gasket (3) over eight studs.

(4) Replace adapter plate (2) and secure with eight self-locking nuts (1).

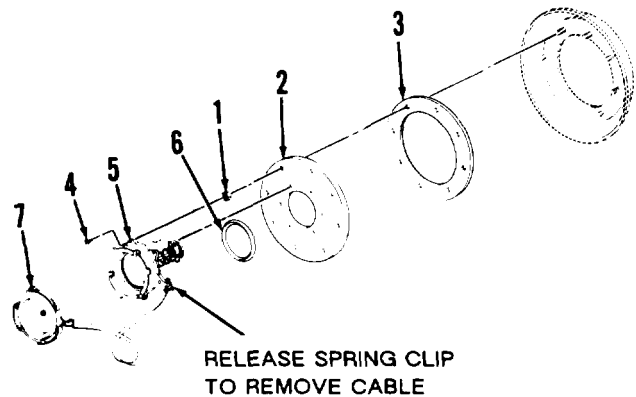

- |                         |                       |
|-------------------------|-----------------------|
| 1. Self-locking nut (8) | 5. Adapter            |
| 2. Adapter plate        | 6. O-ring             |
| 3. Gasket               | 7. Dust cap and cable |
| 4. Screw (6)            |                       |

TA099872

**Figure 4-142. Recirculation Adapter (M970 and M970A1).**

*b. Replacement of Adapter.*

- (1) Remove six screws (4).
- (2) Remove adapter (5) and O-ring (6) by pulling adapter from the adapter plate (2).
- (3) Install O-ring (6) in groove on adapter.
- (4) Install adapter (5) into hole in adapter plate and secure with six screws.

*c. Replacing Dust Cap.*

- (1) Remove the dust cap (7) from the adapter (5).
- (2) Release the spring clip at the adapter (5) and remove cable and dust cap (7).
- (3) Attach spring clip to the adapter (5) and install dust cap (7) on adapter.

**4-89. Hose Reel Hoses and Fittings**

*a. Replacement of 1¼-inch Hoses (M969 and M969A1) and 1½-inch Hose (M970 and M970A1).*

(1) *Removal.*

**NOTE**

**On M969 and M969A1, remove nozzle and bushing reducer.**

- (a) Remove nozzle from end of hose (paras 4-14 through 4-16, and 4-97).
- (b) Release hose reel lock (figs. 2-14 and 2-15) by turning hand wheel counterclockwise. Completely unwind hose. Make sure you can reach the end of the hose.

**WARNING**

**To avoid movement of hose reel by accidental activation of hose reel rewind switch, tighten hose reel lock.**

- (c) Lock hose reel in place by turning hand wheel clockwise until tight.
- (d) Unscrew hose fitting from elbow on hose reel.
- (e) Remove quick-disconnect fitting from other end of hose (M970 and M970A1 only).

(2) *Installation.*

- (a) Replace quick-disconnect fitting on new hose (M970 and M970A1 only).
- (b) Attach new hose to elbow of hose reel and tighten.
- (c) Loosen hose reel lock and rewind hose (para 2-11).
- (d) Install proper nozzle to hose (paras 3-14 through 3-16 and 4-97).

*b. Replacement of 2½-inch Hose (M970 and M970A1).*

(1) *Removal.*

- (a) Remove underwing nozzle from hose (para 3-17).
- (b) Release hose reel lock (fig. 2-15) by turning hand wheel counterclockwise. Completely unwind hose. Make sure end of hose is accessible for removing hose.

**WARNING**

**To avoid movement of hose reel by accidental activation of hose reel rewind switch, tighten hose reel lock.**

- (c) Lock hose reel in place by turning handwheel clockwise until tight.
- (d) Remove quick disconnect fitting from outlet end of hose.
- (e) Disassemble breakaway fitting into two pieces. Unscrew 45° elbow from hose fitting.

(f) To disassemble further, remove capscrews which secure the flange adapter (fig. 4-143) to the hose reel outlet elbow. Remove elbow, breakaway fitting, and adapter assembly. Place assembly in vise and remove adapter flange and elbow from the breakaway fitting.

(2) *Installation.*

- (a) Replace quick-disconnect fitting on new hose.
- (b) Assemble breakaway fitting half and flange adapter.
- (c) Replace O-ring in groove of flange adapter and install assembly onto hose reel outlet elbow. Secure with four capscrews.

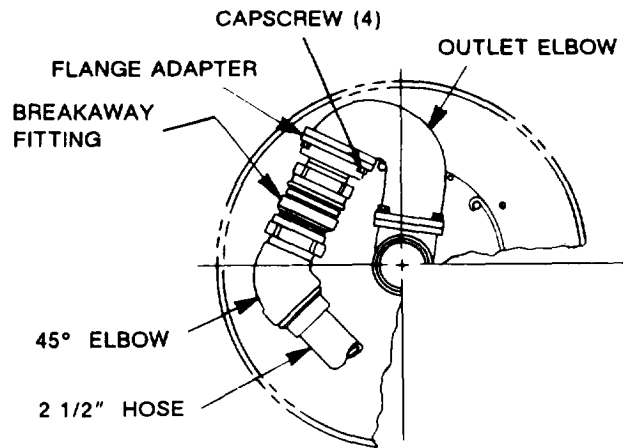

TA099873

**Figure 4-143. 45° Elbow and Breakaway Fitting Replacement.**

(d) Attach 45° elbow and breakaway fitting half to new hose.

(e) Assemble breakaway fitting (para 3-13).

(f) Loosen hose reel lock and rewind hose (para 2-11).

(g) Install underwiring nozzle onto hose (para 3-17).

c. Replacement of Hose on Deadman Hose Reel (M970 and M970A1).

(1) Removal.

(a) Pull hose reel out far enough to remove deadman control from hoses.

(b) Remove the two screws and nuts on the deadman control to free the valve assembly (fig. 4-145).

(c) Disconnect the two hoses from the valve assembly.

(d) Remove the hose ball stop from hose by removing the two screws securing the two halves together.

**NOTE**

**Do not unwind hose reel fully. Hose reel may not release to rewind.**

(e) Pull remaining hoses from hose reel. Make sure you can reach the ends of the hoses.

**WARNING**

**With hose pulled from hose reel, the reel is under spring tension. Be careful not to release hose reel when removing hoses. Personal injury could result.**

(f) Disconnect hoses from elbows on the hose reel and remove (fig. 4-144).

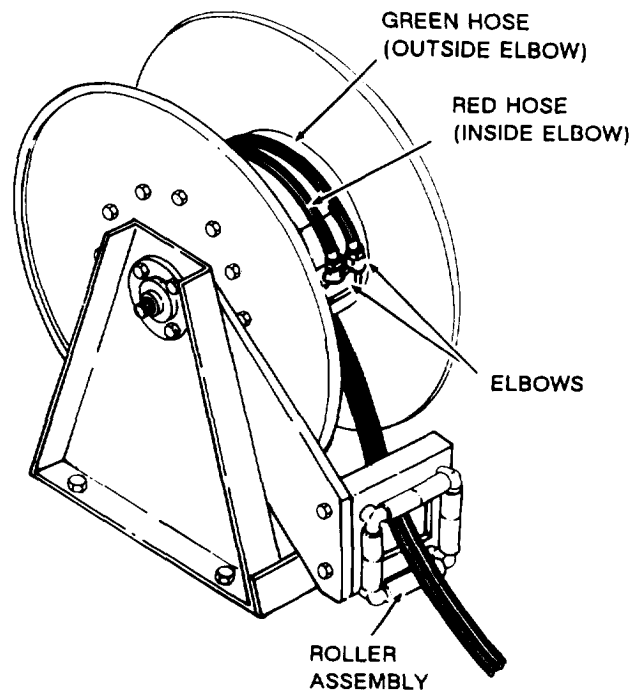

TA099874

**Figure 4-144. Installation of Hoses to Deadman Hose Reel.**

(2) Installation.

(a) Thread red hose through opening in handle guard (fig. 4-145) and attach to OUT port of valve assembly. Attach green hose to IN port of valve assembly.

(b) Replace valve assembly in handle guard of deadman control. Secure with two screws and nuts.

(c) On green hose, replace the hose ball stop about 12-inches from the deadman control.

(d) Thread the two hoses through opening in hose roller assembly (fig. 4-144).

(e) Attach green hose to outside elbow (fig. 4-144) on hose reel and attach red hose to inside elbow.

(f) Pull hoses to release latch on hose reel and rewind the hoses.

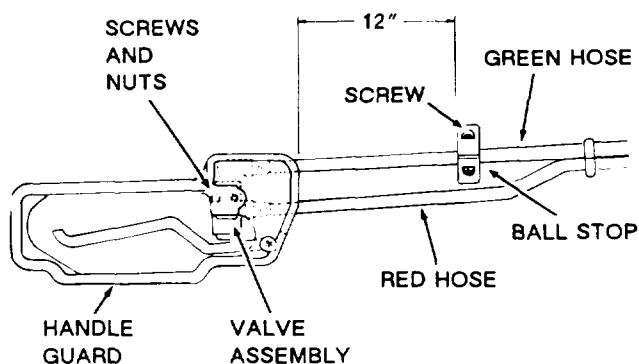

TA099875

Figure 4-145. Deadman Control.

#### 4-90. Centrifugal Pump

a. *Lubrication.* Lubricate the intermediate housing bearing weekly. Refer to figures 3-1 through 3-6 for lubrication instructions and correct lubricant.

b. *Priming.* Whenever pump has lost its prime, remove fill plug (fig. 4-146) and fill pump housing to bottom of fill port with the type of fuel being transported in the semitrailer tank.

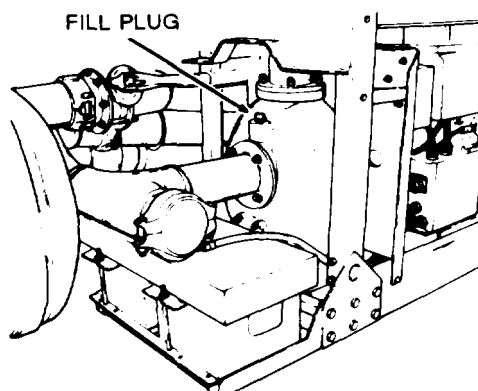

TA099876

Figure 4-146. Priming Centrifugal Pump.

#### 4-91. Dispensing Piping

a. *Removal.*

(1) Review General Instructions before removing any piping (para 4-85).

(2) Use figures 4-147 through 4-149 as guides to which valves, couplings, etc. must be removed in order to remove the piping.

(3) Tag and disconnect any nylon tubing from the

b. *Installation.*

(1) Use figures 4-147 through 4-149 as guides to

(2) Refer to paragraph 4-85 for installation of couplings.

#### 4-92. Control Tubing

a. *Precheck Circuit (M970 and M970A1) (Fig. 4-150).* The circuit is used to check the float valve for proper operation (para 2-11) during bottom load operations. The circuit includes the precheck valve, the float valve, and all necessary tubing and fittings (fig. 4-150).

(1) *Precheck Valve.*

(a) In the open position, this valve allows fluid from the inlet of the 4-inch control valve to reach the float valve at port X (fig. 4-150A).

(b) The fluid raises a float in the float valve and shuts off fluid flow through port Y (fig. 4-150B).

(c) With flow shut off, the pressure in the line to port Y is equalized. A spring in the 4-inch control valve then closes the 4-inch control valve and stops bottom load operations.

(2) *Float Valve.*

(a) This valve automatically closes the 4-inch control valve when fuel level inside the tank rises to a predetermined level during bottom load operation.

(b) With precheck valve in the closed position, fluid rises in the tank until it reaches the float valve (fig. 4-150C). There it enters float valve and raises the float, which shuts off the fluid entering in port Y of the float valve.

(c) With flow shut off at port Y, the pressure in the line to port Y is equalized. A spring in the 4-inch control valve then closes the 4-inch control valve and stops the bottom load operation.

b. *Precheck and Load/Unload Circuit (M967, M967A1, M969, and M969A1) (Fig. 4-151).* This circuit is used to check the float valve for proper operation (para 2-11) during bottom load operations. In addition, a load/unload valve is added to the circuit to shut off 4-inch control valve during bulk delivery operations. The circuit

includes a precheck valve, load/unload valve, and float valve (fig. 4-151).

(1) *Precheck Valve.*

(a) In the open position, this valve allows fluid from the inlet of the 4-inch control valve to reach the float valve at port X (fig. 4-151A).

(b) The fluid raises a float in the float valve which shuts off fluid flow through port Y (load/unload valve must be in a load position).

(c) With flow shut off, the pressure in the line to port Y is equalized (fig. 4-151B). A spring in the 4-inch control valve then closes the 4-inch control valve and stops bottom load operation.

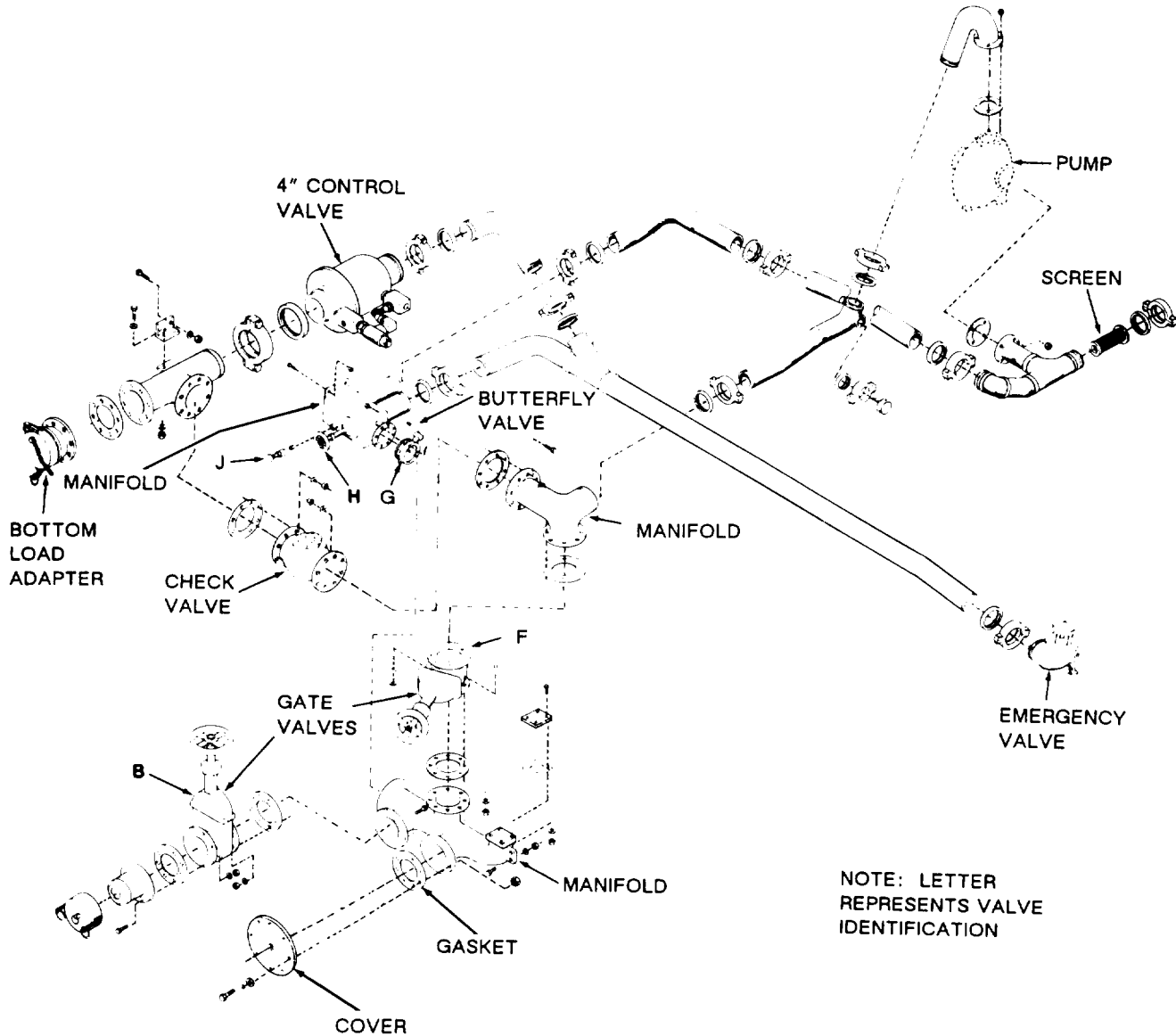

Figure 4-147. Dispensing System (M967 and M967A1).

TA502367

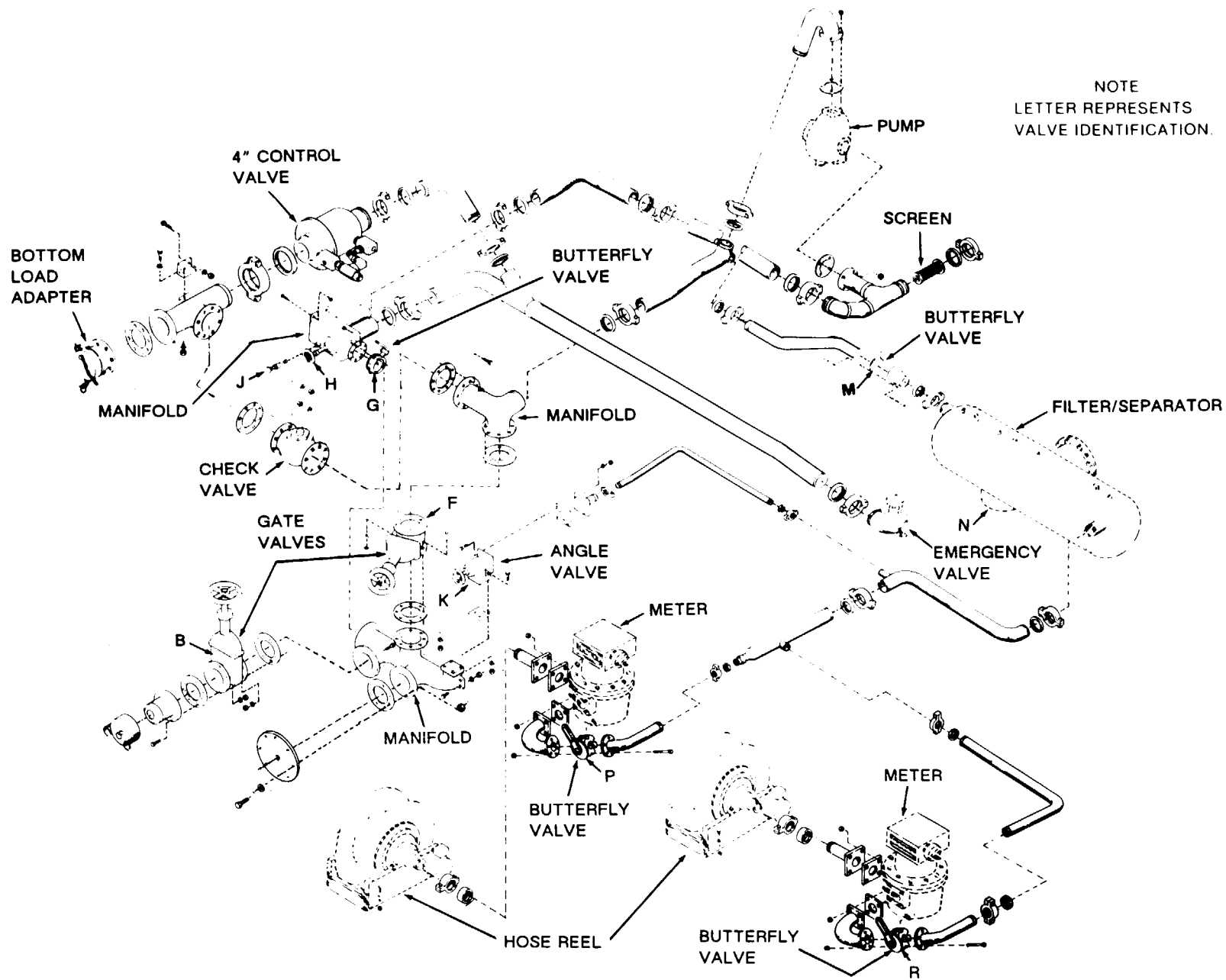

Figure 4-148. Dispensing System (M969 and M969A1).

TA502368

TM 9-2330-356-14

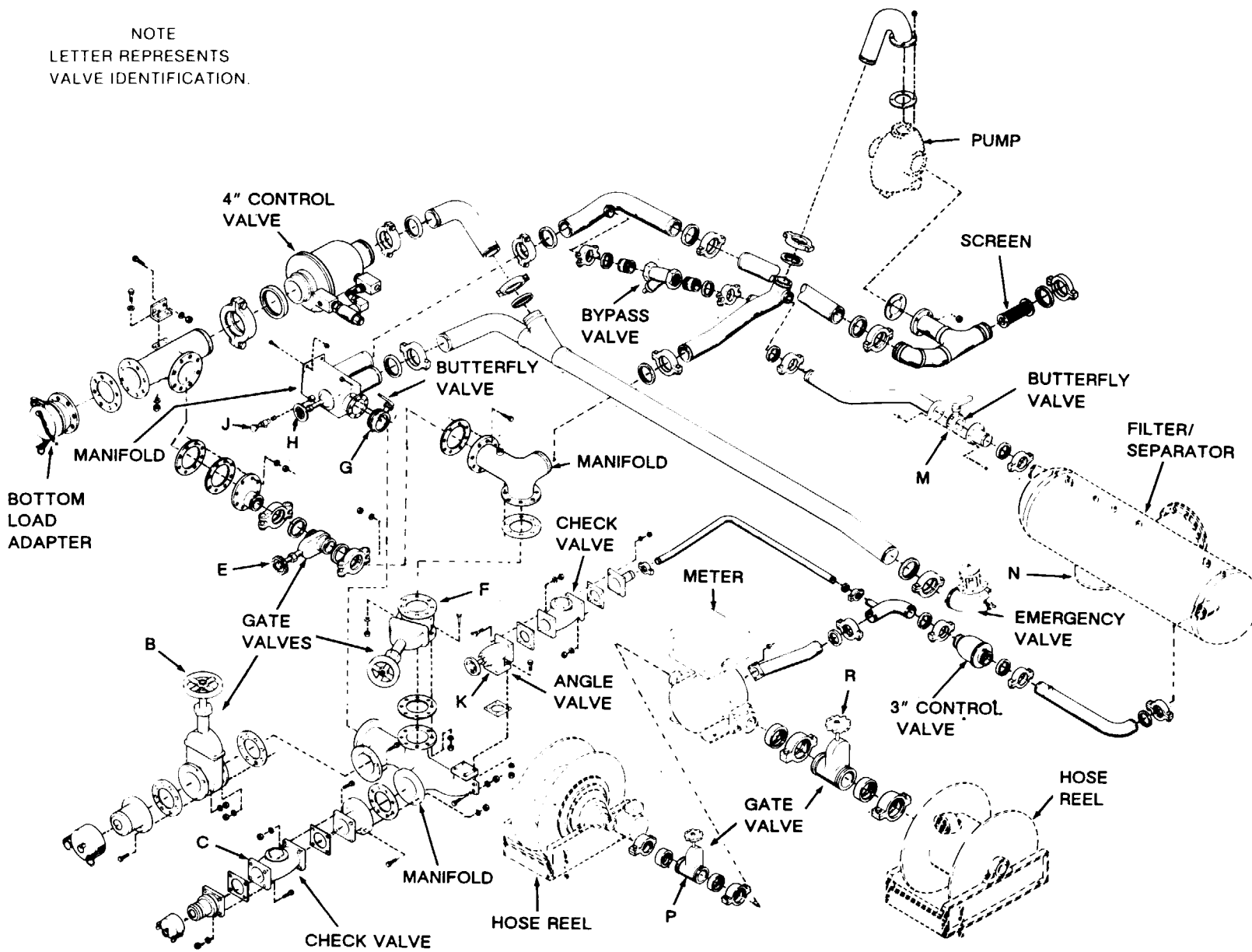
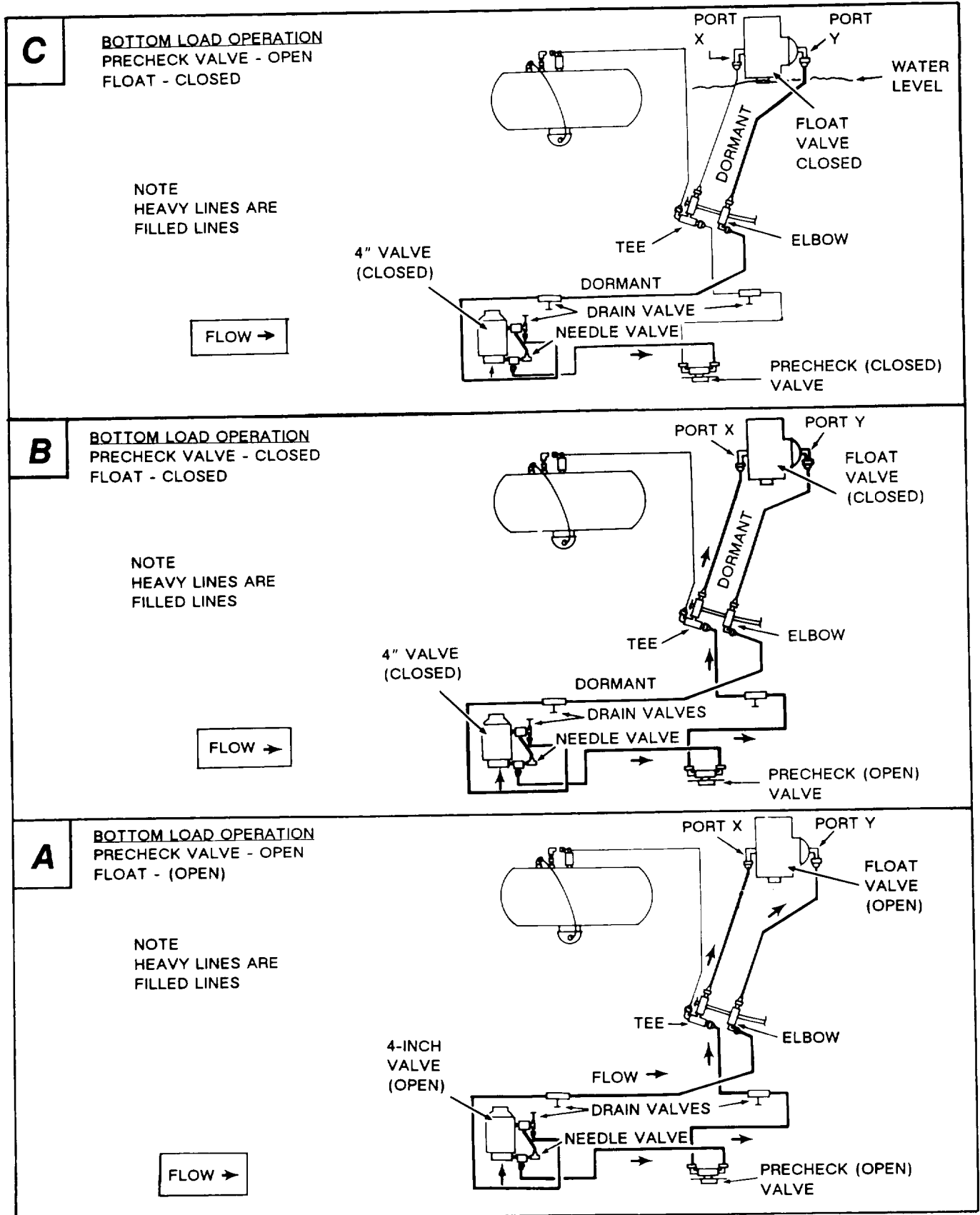

Figure 4-149. Dispensing System (M970 and M970A1).

TA099879





TA099880

Figure 4-150. Precheck Flow Diagram (M970 and M970A1).

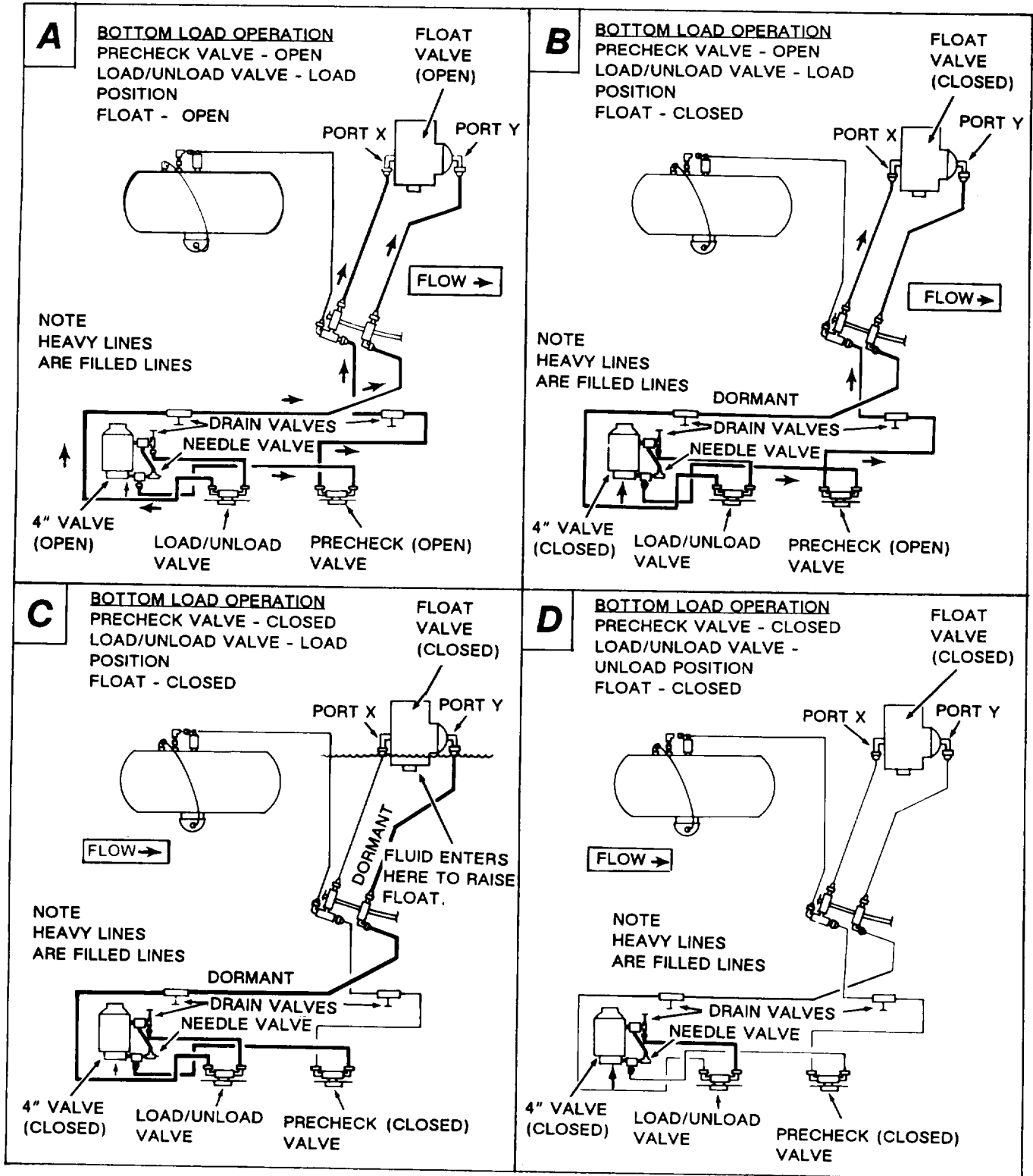

Figure 4-151. Precheck and Load/Unload Flow Diagram (M967, M967A1, M969, and M969A1). TA099881

*(2) Float Valve.*

(a) This valve automatically closes the 4-inch control valve when fuel level inside tank rises to a predetermined level during bottom load operation.

(b) With precheck valve in the closed position, fluid rises in the tank until it reaches the float valve (fig. 4-151C).

(c) There it enters float valve and raises the float which shuts off the fluid entering in port Y of the float valve (load/unload valve must be in load position).

(d) With flow shut off at port Y the pressure in the line to port Y is equalized. A spring in the 4-inch control valve then closes the 4-inch control valve and stops the bottom load operation.

*(3) Load/Unload Valve.*

(a) Unlike the M970 and M970A1, the M967, M967A1, M969, and M969A1 do not provide a means to manually shut down flow to the 4-inch control valve during bulk delivery operations.

(b) During these operations, fuel exiting the pump will follow two paths; one to either the piping control or the filter/separator (dependent on operation) and the other to the 4-inch control valve.

(c) When the fuel reaches the 4-inch control valve inlet, the valve opens and allows fuel to follow a path back to the pump. Consequently, the pump actually recirculates the fuel in the piping system. Therefore, when performing bulk delivery operations, the load/unload valve is switched to the unload position. This closes the load/unload valve and disrupts the flow in the line to port Y on the float valve before it reaches the float (fig. 4-151D).

(d) Because the load/unload valve is connected in series in the line to port Y, when precheck operation or loading operations are performed, the load/unload valve must be in the load (open) position (fig. 4-151A and 4-151B).

*c. Deadman Control Circuit (M970 and M970A1) (Fig. 4-152).*

(1) When the underwing nozzle is used in conjunction with the 2½-inch hose reel, the deadman control is used to control the fuel flow through the underwing nozzle.

(2) The deadman control S (fig. 4-152) is a hand-held control which uses air pressure from the

secondary air reservoir to operate a normally closed pilot valve A on the 3-inch control valve.

(3) When the normally closed pilot valve A is closed, fuel from the inlet side of the 3-inch control passes through a needle valve and into the 3-inch control valve spring chamber. It also passes through normally open pilot valves B and C on its way to the manifold.

(4) Fuel also flows through the 3-inch control to the 2½-inch hose reel.

(5) As it enters the hose reels, fuel is bled off through a pilot line, through the check valve portion of deadman release valve, to the normally-open pilot valve B.

(6) The fuel pressure closes pilot valve B, creating pressure in the spring chamber of the 3-inch control valve. The additional pressure created on the valve poppet of the 3-inch control valve closes the valve, stopping flow to the underwing nozzle.

(7) To open the control valve, the trigger on the deadman control is squeezed, and air from the secondary air reservoir is directed to the normally-closed pilot valve A to open the pilot valve.

(8) Once Valve A is open, the pressure in the spring chamber of the 3-inch control valve is relieved and the control valve opens.

(9) When the water level in the filter/separator sump is high enough to raise the float in the automatic drain valve, pilot pressure is sent through the pilot line from the automatic drain valve to the pilot valve C.

(10) The pilot valve C closes, creating pressure in the spring chamber of the 3-inch control valve.

(11) The additional pressure created on the valve poppet of the 3-inch control valve closes the valve, stopping flow to the underwing nozzle.

(12) When water is drained from the filter/separator, the float lowers and shuts off the pressure to the pilot valve C. Pilot valve C opens and flow through the 3-inch control valve continues.

*d. Removal of Control Tubing.*

(1) *General.* The general arrangement of the control tubing is shown in figures 4-153 through 4-155. The control tubing is nylon and is fastened in various locations with straps.

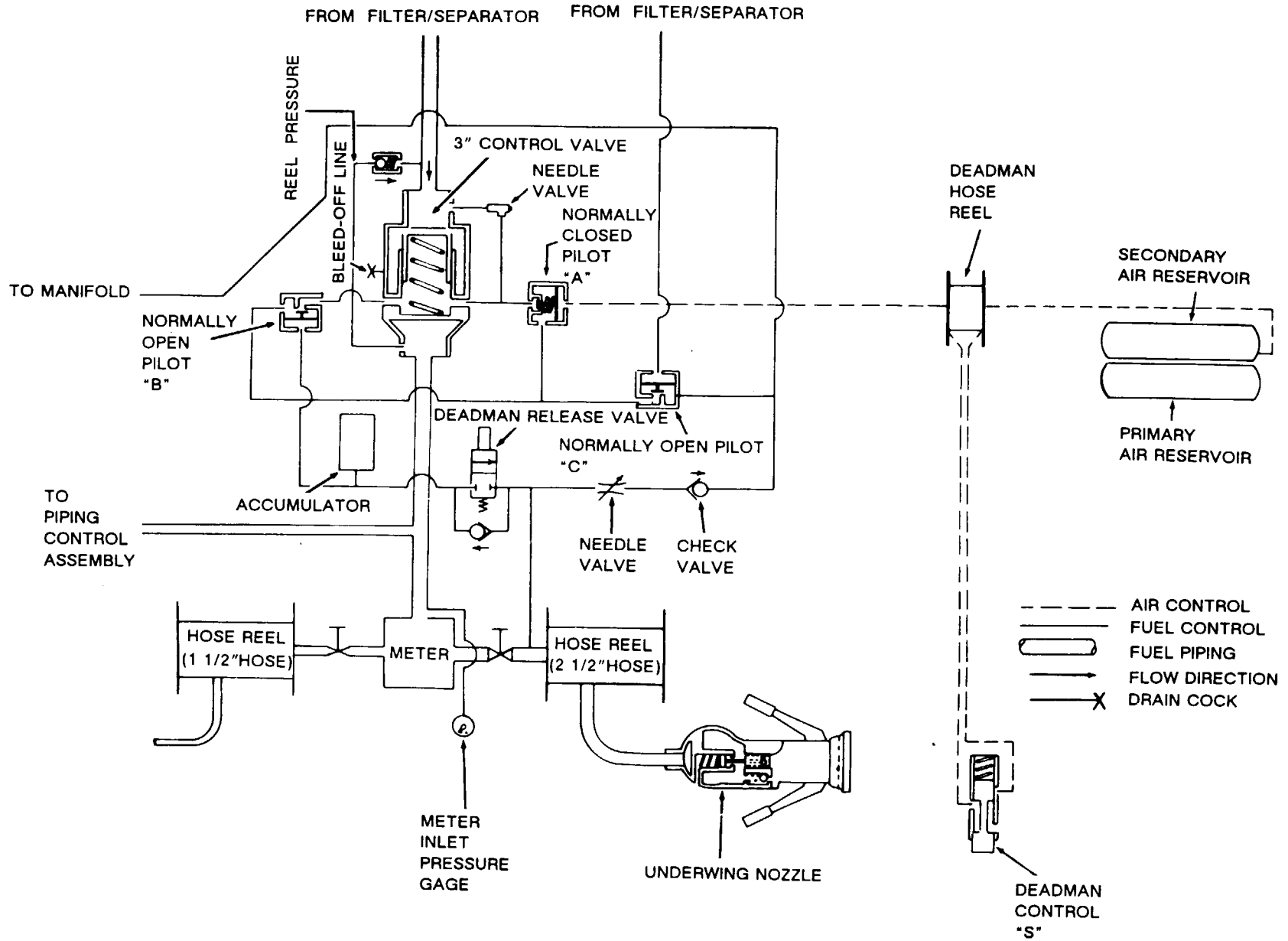
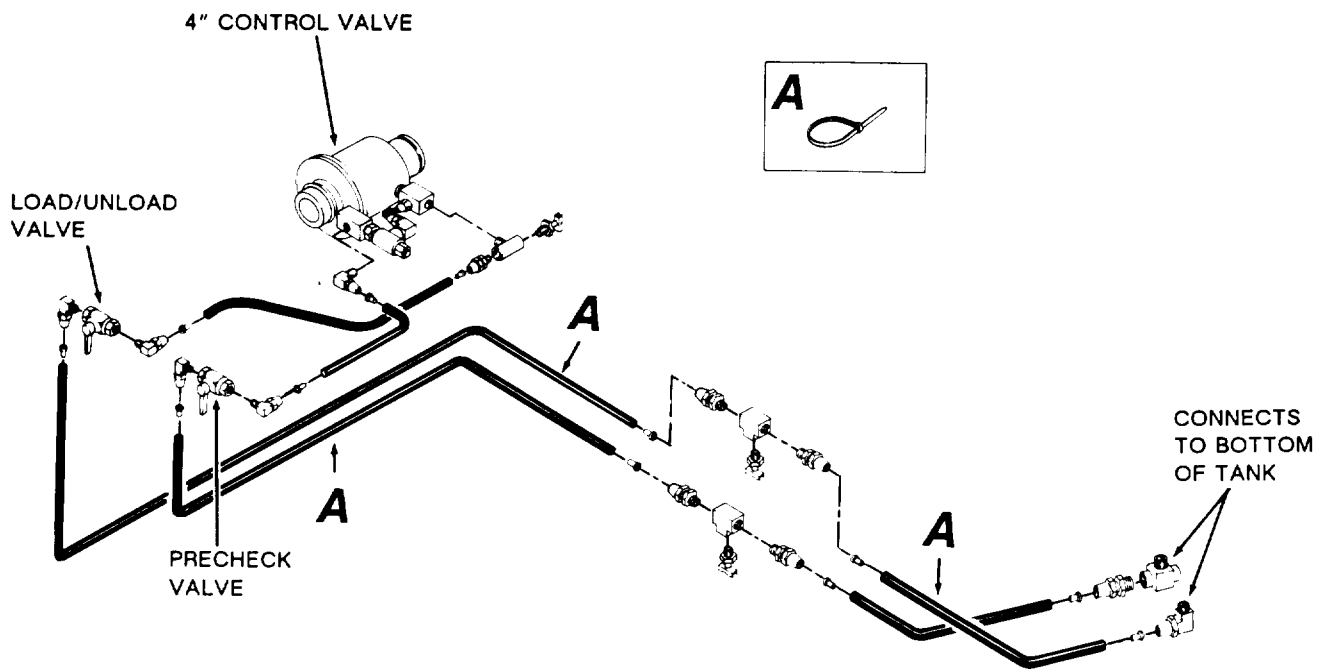
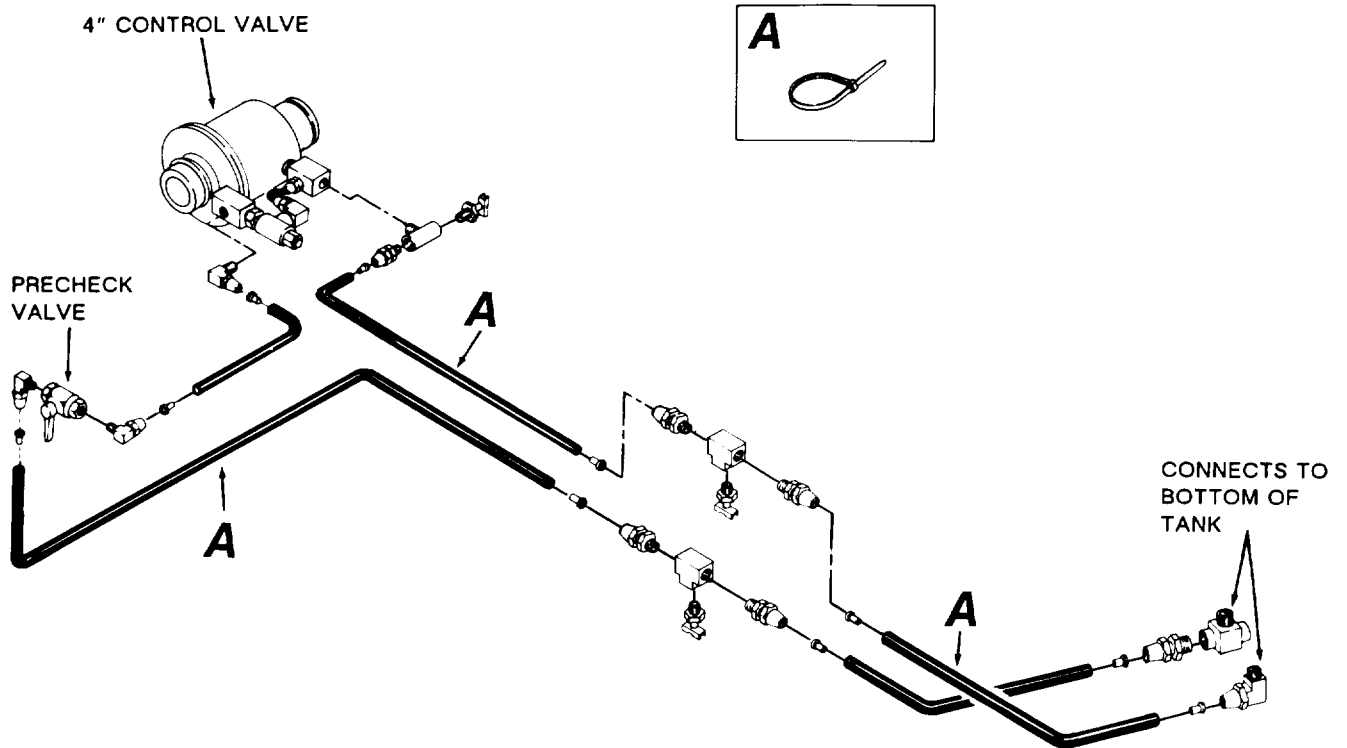

Figure 4-152. Deadman Control System Schematic (M970 and M970A1).



TA098883

Figure 4-153. Precheck Circuit and Load/Unload Circuit Tubing and Fittings (M967, M967A1, M969, and M969A1).



TA099884

Figure 4-154. Precheck Circuit Tubing and Fittings (M970 and M970A1).

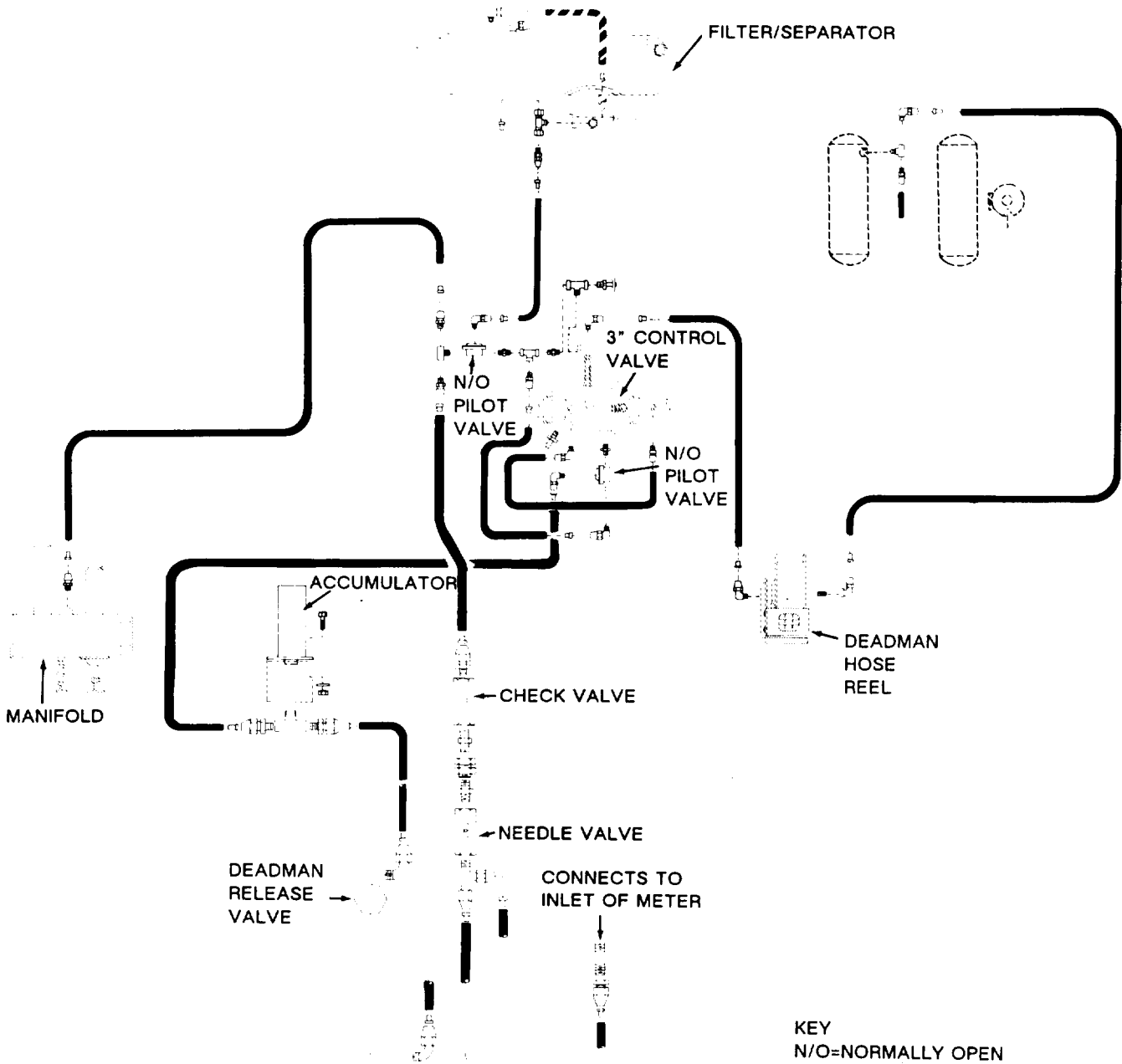

TA099885

**Figure 4-155. Deadman Control Tubing and Fittings (M970 and M970A1).**

(2) *Replacement of Nylon Tubing.*

(a) Wherever possible drain control tubing by opening drain cocks (fig. 2-25).

(b) Disconnect tubing from fitting and remove insert, compression sleeve, and nut on both ends of tubing.

(c) Remove straps, if necessary, and remove tubing.

**NOTE**

**Tubing is stocked in bulk lengths.**

(d) Measure original tubing and cut new tubing about six inches longer to allow for trimming.

(e) Trim ends of tubing to get a smooth, square cut. Slide tubing nut onto the end of tube, install compression sleeve over end of tube, and install tubing insert. Connect tubing to adapter fitting and tighten tubing nut securely. Repeat procedure on other end of tubing.

(f) Secure tubing with straps where needed.

e. *Control Tubing Fittings.* Use antiseize tape (item 28, Appendix E) on all male threads. Take care not to let any of the tape get into the system.

**4-93. Precheck and/or Load/Unload Valve (Fig. 4-156)**

a. *Removal.*

- (1) Remove the screw holding the handle to the valve stem.
- (2) Remove handle.
- (3) Loosen and remove the nut and washer securing valve to control panel plate.
- (4) Remove valve from rear of plate.
- (5) Tag and disconnect the two nylon tubes from the elbows at the valve.
- (6) Remove two elbows from valve.

b. *Installation.*

- (1) If new valve is being installed, remove handle, nut, and washer.
- (2) Replace elbows in valve by turning elbows until tight. Elbows must be positioned to the rear of valve.
- (3) Connect the two nylon tubes to the elbows. Be sure notch in threaded portion of valve is facing down.
- (4) Position valve through hole in panel.
- (5) Replace washer and nut to secure valve to plate.
- (6) Replace handle on valve stem and secure with screw.

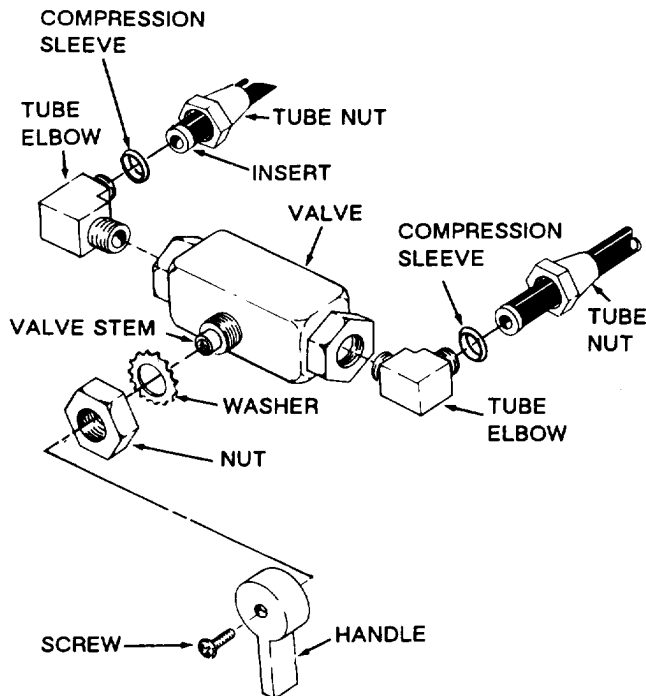

TA099886

**Figure 4-156. Precheck and/or Load/Unload Valve Installation.**

**4-94. Deadman Release Valve (Fig 4-157)**

a. *Removal.*

- (1) Tag and disconnect the two nylon tubes from the tube elbows by unscrewing tube nuts.
- (2) Loosen and remove the top nut from valve.
- (3) Remove valve from bracket.
- (4) Remove two tube elbows from valve body.

b. *Installation.*

- (1) Replace tube elbows onto valve.
- (2) Position valve in bracket and secure with top nut.
- (3) Insert the two nylon tubes into the two tube elbows. Screw tube nuts onto elbow securely.

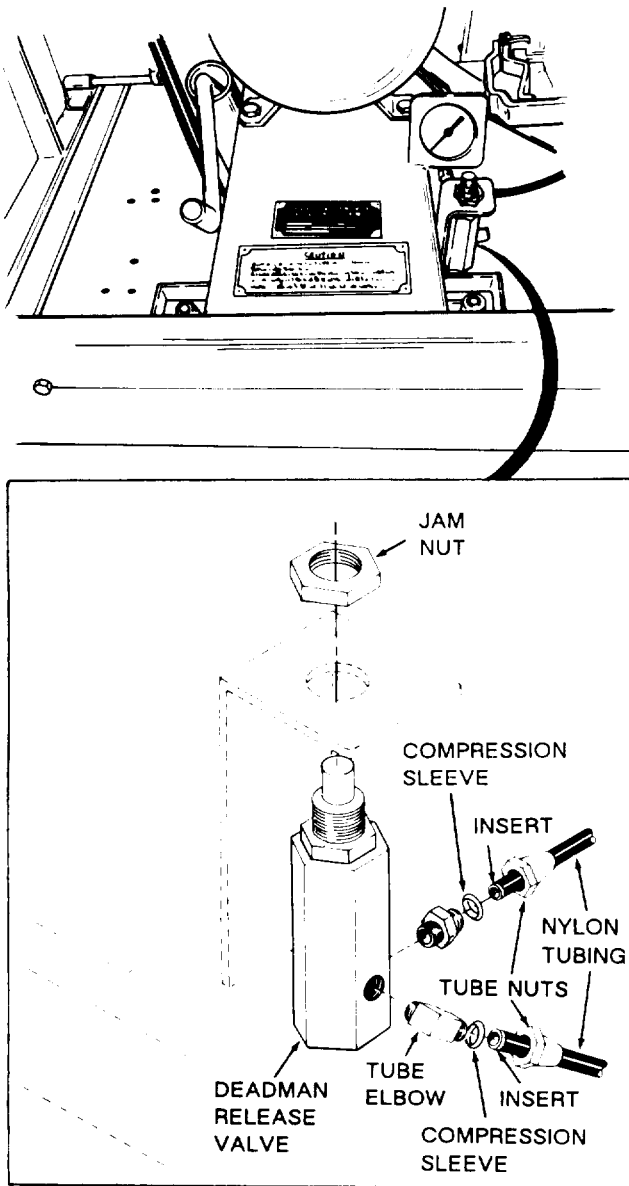

TA099887

**Figure 4-157. Deadman Release Valve.**

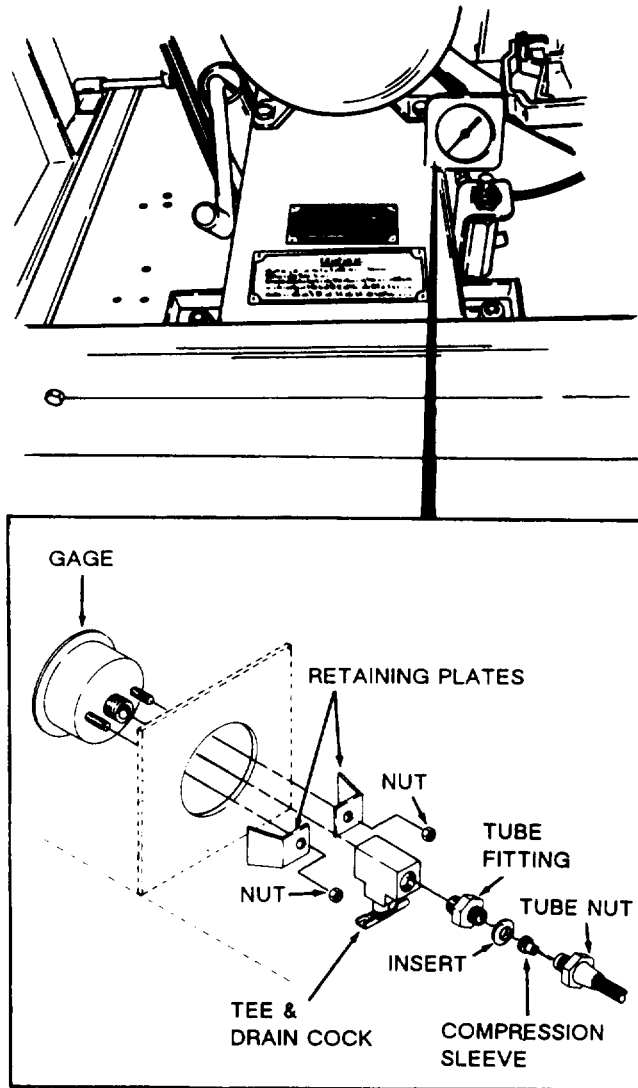

TA099889

**Figure 4-158. Meter Inlet Pressure Gage.**

**4-95. Meter Inlet Pressure Gage (Fig. 4-158)**

*a. Removal.*

- (1) Disconnect the nylon tube from tube fitting.
- (2) Remove two nuts that secure retaining plates to rear of gage and remove plates. Then remove gage.
- (3) Remove tee and drain cock assembly from rear of gage.

*b. Installation. Reverse instructions in step a.*

**4-96. Static Reel (Fig. 4-159)**

*a. Removal.*

- (1) Remove two capscrews, four washers, and two self-locking nuts that secure static reel to cabinet.
- (2) Remove static reel from cabinet.

*b. Installation.*

- (1) Place static reel in cabinet and position mounting holes.
- (2) Install two capscrews, four washers, and two self-locking nuts.



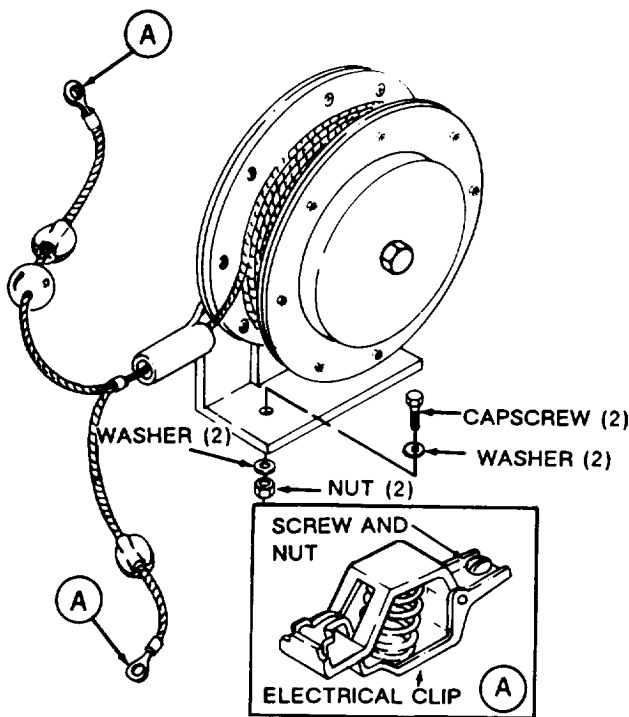

TA502369

Figure 4-159. Static Reel.

c. *Replacement of Electrical Clip.* Remove screw and nut that attaches clip to cable, then remove clip. Remove screw and nut from new clip and replace securing cable between head of screw and clip.

**4-97. Vehicle Nozzle (M969 and M969A1)**

a. *Removal.*

(1) Pull hose reel hose out far enough to work on nozzle easily.

(2) Unscrew nozzle from end of hose.

(3) If reducer is removed with nozzle, unscrew bushing and screw back into hose.

b. *Installation.* Screw nozzle into reducer bushing on end of hose. Tighten securely. Rewind hose reel hose (para 2-11).

**4-98. Vapor Recovery Piping (Fig. 4-160)**

a. *Replacement of Vapor Recovery Hood and Hose.*

(1) *Removal.*

(a) Loosen clamp (6) and remove hood (7).

(b) Loosen hose clamp (1) and slide off hose and hood as a unit.

(c) Loosen hose clamps (2) and (4), and remove hose (3) and pipe (5).

(d) Loosen clamp (8) and remove plug (9).

(2) *Installation.*

(a) Reverse instructions in step (1).

b. *Replacement of Piping.*

(1) *Removal.*

(a) Remove coupling (10) from coupling (11).

(b) Remove two nuts and bolts from coupler (12) and remove coupler.

(c) Provide support for pipe assembly (16) so it will not fall.

(d) Remove four nuts (13), four washers (14), and two U-bolts (15). Remove pipe assembly (16).

(e) Remove coupling (11) from pipe.

(f) Remove eight capscrews (17) and nuts (18).

(g) Remove vent (19) and gasket (20).

(2) *Installation.* Install pipe in reverse order of removal steps (a) through (g). When installing coupling (12), refer to paragraph 4-85.

c. *Replacement of Ground Receptacle.*

(1) *Removal.*

(a) Remove ground wire from tool box by removing screw and nut.

(b) Remove two screws (21, fig. 4-160) and nuts (22) and remove receptacle (23).

(c) If bracket (24) is to be removed, remove two capscrews (25) and nuts (26), and remove bracket (24).

(2) *Installation.* Install ground receptacle by reversing steps (a) through (c).

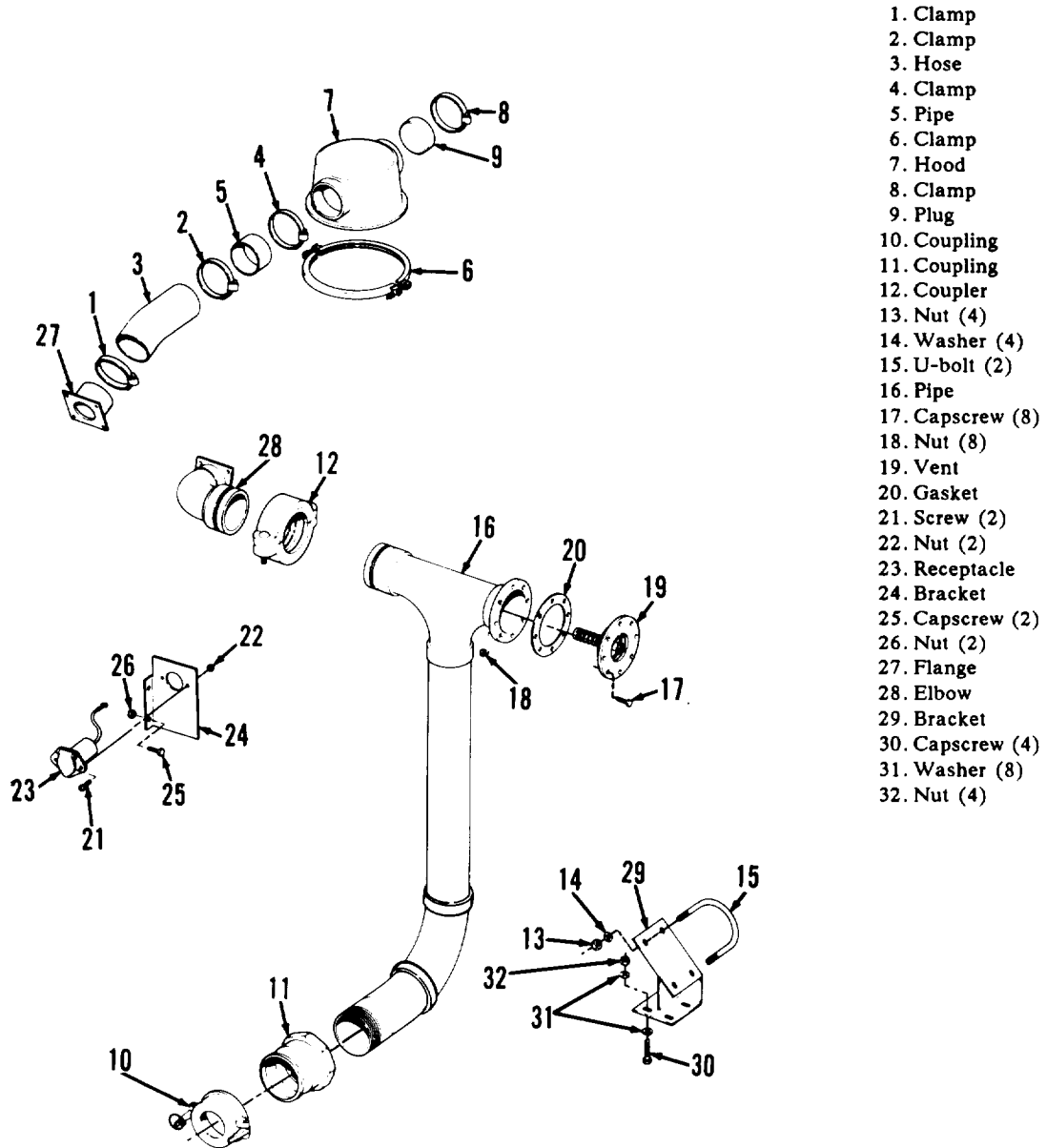

- 1. Clamp
- 2. Clamp
- 3. Hose
- 4. Clamp
- 5. Pipe
- 6. Clamp
- 7. Hood
- 8. Clamp
- 9. Plug
- 10. Coupling
- 11. Coupling
- 12. Coupler
- 13. Nut (4)
- 14. Washer (4)
- 15. U-bolt (2)
- 16. Pipe
- 17. Capscrew (8)
- 18. Nut (8)
- 19. Vent
- 20. Gasket
- 21. Screw (2)
- 22. Nut (2)
- 23. Receptacle
- 24. Bracket
- 25. Capscrew (2)
- 26. Nut (2)
- 27. Flange
- 28. Elbow
- 29. Bracket
- 30. Capscrew (4)
- 31. Washer (8)
- 32. Nut (4)

Figure 4-160. Vapor Recovery Piping.

TA099890

**Section XX. DRAINING AND PURGING OF TANK INTERIOR**

**4-99. General**

**proper draining, purging, and cleaning methods.**

**NOTE**

**A thorough reading of FM 10-20 and TB 43-0212 is essential for understanding**

- a. Removal of combustible vapors and liquids requires a coordinated effort of properly skilled safety and maintenance personnel. This maintenance procedure is to

be performed by authorized unit or direct support personnel with an MOS of 77F or equivalent.

*b.* There are several methods available to eliminate combustibles from fuel tankers. The primary method is by use of a purging chemical. Using a chemical to purge saves time, labor, and material compared to other methods. It greatly reduces the possibility of a combustible vapor buildup after the purging procedure has been completed and after the vapor test readings show a safe level.

*c.* Alternate methods include steam, forced air, and oil purge.

*d.* The methods described here will be chemical, steam, and forced air.

*e.* If the semitrailer is being shipped after draining and purging, refer to Chapter 4, Section XXI for supplemental instructions.

#### 4-100. Draining Tank

##### **WARNING**

**Discontinue all operations if an electrical storm is threatening or in progress. Open flames or other sources of ignition, such as welding and cutting torches and ordinary electrical equipment, shall not be introduced in areas where flammable vapors may be present. The tank being drained and purged shall be statically grounded prior to, and during, all operations.**

*a.* Before any purging is started, semitrailer tank and piping must be drained into suitable containers, or an oil/water separator.

*b.* Select a level area 100-feet from any building, source of ignition, or sewer system. Position semitrailer so that the tank sump is in the lowest position.

*c.* Have sufficient fire extinguishers available, placed 50-feet upwind, and manned by qualified personnel.

*d.* Static ground the semitrailer to an approved (earth) ground.

*e.* Place conductive metal or galvanized containers under all drain points. Ground containers to tank and to tank's common ground. Grounding connections shall be made to clean, unpainted surfaces.

##### **CAUTION**

**Meters should be air dried thoroughly to eliminate rusting of internal moving parts.**

*f.* Completely drain tank interior, all piping, pump, meters, and filter/separator. Remove all accessory items, such as gages and floats, which might entrap fuel. Drain the equipment that has been removed. Wipe dry all connections. Cloths or mops used are to be washed, dried, and stored, or disposed of safely.

#### 4-101. Purging Tank

##### **WARNING**

- **Should an emergency arise requiring entry into a tank which is not vapor-free, or which has an oxygen content less than 19.5 percent, personnel who enter the tank shall have an attached lifeline and wear protective respiratory equipment. In the form of either a self-contained breathing apparatus or a full facepiece mask with a pressure supply of respirable air. Another person, also provided with respiratory equipment, shall be stationed at the manhole opening and remain there to watch personnel in the tank and summon assistance if a rescue operation becomes necessary. Personnel should not enter a tank which is in the explosive range.**

- **All vapor-freeing work by any method should be carried on outdoors, remote from vehicles and other known sources of ignition, and the tank unit must be stationed where flammable vapors will not blow or drift indoors. Failure to follow this warning may result in serious injury or death to personnel.**

- **Combustible vapor testing must be conducted as prescribed in this manual and current field manuals and technical bulletins. Vapor testing should not be conducted during steam cleaning since excess moisture or lack of oxygen may cause false readings.**

*a.* Do not wear wool, nylon, silk, rayon, or other clothing having a tendency to generate static electricity.

*b.* Wear clean cotton clothing with no metal buttons, zippers, or fasteners. Remove all contents from pockets.

*c.* Wear rubber boots and rubber gloves.

d. Use cotton waste for cleaning purposes; other material may generate static electricity.

e. *Required Materials.*

(1) Adequate source of water with a large diameter hose long enough to reach the semitrailer.

(2) Compressed air source and air hoses of sufficient length to reach bottom of semitrailer tank.

(3) Sufficient quantity of gas tank purger chemical obtainable through local procurement. Purging chemical No 913, Product-Sol Inc., 2010 Cole Avenue, Birmingham, Michigan 48008 is the only known source available to date. Purging chemical can be procured at a cost of approximately \$70.00 per 5 gallons, or \$420.00 per 55 gallons, plus shipping cost.

(4) Combustible gas indicator set (NSN 6665-00-664-4650 or NSN 6665-00-292-9945). The equipment is listed as a Common Table of Allowance (CTA) item in SB 700-20 and is line item number E57351.

(5) Entry into a tank which is not vapor-free or which has an oxygen content less than 19.5% require the following: Protective respiratory equipment; lifeline; approved explosion-proof extension light or flashlight; steam or air-operated venturi-type air mover or a fan-type blower with an air duct.

f. *Purging-Chemical Method.*

(1) After draining tank, close or seal all valves and drain points.

(2) Fill tank with cold water and allow to overflow for five minutes or until all traces of flammable material are removed. Drain tank completely.

(3) Close or seal all valves and drain points.

#### CAUTION

**Insufficient amount of chemical will result in an incomplete purging. Once purging has begun, do not stop until process is complete.**

(4) Add to tank 40-fluid ounces of the chloro-carbon base purging chemical for each 100-gallon capacity. A 5000 gallon tank will take approximately 17 gallons of purging chemical.

(5) Fill tank to top with water. Do not overflow.

(6) Insert air line through manhole and vent cap openings and agitate solution with 3-5 psi of air for 40 minutes. Frequently move air hoses around in tank,

covering as much area as possible, especially near the bottom and around baffles. Remove air lines and drain solution from tank at all valves and drain points.

(7) Fill tank with cold water and allow to overflow for 5 minutes or until water is clear. Drain tank completely at all valves and drain points.

(8) Conduct a combustible vapor test to determine if tank is safe to repair, clean, paint, store, change material, or ship. Take reading in several areas of the tank. If test reading indicates tank is not safe, repeat step (7), until a safe reading is obtained.

g. *Purging-Steam Method.*

(1) This methods is an alternate to the chemical method, It is effective for the removal of high viscosity petroleum products. Low pressure steam is injected into the tank for a period of time to bring the temperature of the tank to 76°C (170°F). Prior to introducing steam, the metallic connection on the discharge end of the steam hose must be bonded to the tank shell and the tank must be grounded.

(2) After draining tank, ensure that all valves and drain points remain open.

(3) Introduce steam through manhole and baffle plate opening in sufficient volume to raise the temperature of the tank to 76°C (170°F). Close manhole fill cover to the extent steam line will permit.

#### CAUTION

**Ensure that steam does not come in contact with electrical wiring and other components. The heat of steam can damage the painted surface of the tank, valve seats, gaskets, and diaphragms, and can weaken fusible plugs.**

(4) Steam the tank for at least three hours. Turn steam source off.

#### CAUTION

**After purging by steam method, leave tank valves and drain points open during cool-down to prevent vacuum collapse of tank.**

(5) Leave an valves and drain points open until tank is fully cooled, at least one hour.

(6) Measure explosive vapor level. Take readings in several areas of the tank. Reading should be 20% lower explosive level (LEL) or less. If LEL is greater than 20%,

repeat steam cleaning for one hour. Continue steaming until 20% LEL or less is obtained.

(7) After the tank has been freed of combustible vapors, it is ready to repair, clean, paint, store, change material, or ship.

*h. Purging-Forced Air.*

(1) Blower/air supply to be used with this procedure shall be an explosion-proof blower conforming to MIL-B-7619 or MIL-H-27507. If these blowers are not available, local safety personnel may authorize the use of another type blower.

(2) After draining tank, leave all valves and drain points open, and grounded drain containers in place to catch fuel during the purging operation. This is to facilitate maximum air circulation.

(3) Place blower/air supply 50-feet upwind of semitrailer. Ground the blower to the static ground and connect duct to outlet side of blower.

(4) Start blower BEFORE inserting duct into manhole opening. This will prevent fuel vapors from entering duct and going into blower.

(5) Ground duct to the vehicle.

(6) Install duct in manhole. Secure with tape or tie to semitrailer.

(7) Purge tank for two hours. During purging operation, observe that air is being expelled at all valves and drain points. Trapped fuel may prevent air from being circulated through all valves and drains. In the event air is not coming out of a valve or drain, temporarily close all other valves and drains and observe if trapped fuel is expelled. Reopen valves and drains.

(8) Remove duct from manhole opening.

(9) Shut off air supply. Wait 10 minutes.

(10) Measure explosive vapor level of tank. Take readings in several areas of the tank. Reading should be 20% LEL or less. If reading is above 20% LEL, resume purging operation following instructions above.

(11) Purge for one hour AFTER a safe reading is obtained.

(12) Remove duct from manhole opening BEFORE shutting off blower.

(13) Close all valves and drains. Leave manhole cover open. Tank is now ready to repair, clean, paint, store, change material, or ship.

#### 4-102. Inspecting and Cleaning Tank Interior

*a. Inspection.*

**WARNING**

**Explosive meter check must be made before entering tank. Air personnel required to be inside of tank must be equipped with fresh air respirators, lifelines, rubber boots, and rubber gloves. An observer must be stationed at the manhole opening so that assistance may be summoned in the event of an emergency.**

(1) Remove manhole lid and enter tank. An explosion-proof light, flashlight, or electric lantern with lens approved for use in hazardous areas must be used for inspecting.

(2) Inspect for sediment, solid deposits, or foreign matter of any kind. Inspect for corrosion and signs of bad welds.

*b. Cleaning Interior.*

**CAUTION**

**Metal tools, steel wool, steel brushes, or any abrasive cleaning powders must not be used to clean tank interiors. Their use would destroy the thin oxidation film.**

(1) *General.* Stainless steel obtains its corrosion resistance from a thin film of oxidation that forms on the surface when exposed to air. Care must be taken not to damage this film.

(2) *Cleaning.* Use a lint-free rag (item 24, Appendix E) to wipe off any sediment or foreign matter of any kind that may adhere to the inside of the tank. A bristle brush can be used to remove solid deposits. Mild household powder or soap may be used for removal of heavy residue.

**WARNING**

**Compressed air used for drying or cleaning purposes must not exceed 30 psi (207 kPa). Wear protective clothing (goggles and gloves) and use caution to avoid injury to personnel.**

(3) *Rinsing and Drying.* Rinse entire interior with warm water. Rinse off all soap with warm water. Dry entire interior thoroughly. Compressed air or centrifugal blowers may be used to speed up drying.

**4-103. Flushing**

**WARNING**

**All pumping procedures must be done outside.**

*a.* Remove all cleaning materials and equipment from the inside of the tank. Close manhole cover. Close all valves and drain points. Put 200-300 gallons of the type fuel to be hauled in the tank.

*b.* Place suitable containers at a convenient location near the hose reel compartment. Following the operating instructions in Chapter 2, discharge about 80 gallons through each hose reel (M969, M969A1, M970, and M970A1). After evacuating the hoses, discharge the remaining fuel through the bulk delivery hose. Shut off engine.

*c.* Place suitable container under drain valve at bottom of filter/separator. Open valve to drain remaining fuel. Remove filter elements and replace with new ones (para 4-83).

*d.* Dispose of the purging fuel per Command SOP.

**Section XXI. PREPARATION FOR STORAGE OR SHIPMENT**

**4-104. General**

*a.* This section contains requirements and procedures for administrative storage of equipment that is issued to and in use by Army activities worldwide.

*b.* *The* requirements specified herein are necessary to maintain the equipment in administrative storage in such a way as to achieve the maximum readiness condition.

*c.* Equipment that is placed in administrative storage should be capable of being readied to perform its mission within a 24-hour period, or as otherwise prescribed by the approving authority.

*d.* Report equipment in administrative storage as prescribed for all reportable equipment.

*e.* Perform inspections, maintenance services, and lubrication as specified herein.

*f.* Records and reports to be maintained for equipment in administrative storage are those prescribed by DA PAM 738-750, for equipment in use.

*g.* When determining maintenance actions required, 10% variance is acceptable on time, running hours, or mileage.

*h.* Accomplishment of applicable PMCS, as mentioned throughout this section, will be on a quarterly basis.

**4-105. Definition of Administrative Storage**

*a.* *The* placement of equipment in administrative storage can be for short periods of time when a shortage of maintenance effort exists.

*b.* Items should be ready for use within the time factors determined by the directing authority.

*c.* During the storage period appropriate maintenance records will be kept.

**4-106. Preparation of Equipment for Administrative Storage**

*a.* *Storage Site.*

(1) Select the best available site for administrative storage. Separate stored equipment from equipment in use. Conspicuously mark the area "Administrative Storage".

(2) Covered space is preferred.

(3) Open sites should be improved hardstand, if available. Unimproved sites should be firm, well drained, and kept free of excessive vegetation.

*b.* *Storage Plan.*

(1) Store equipment to provide maximum protection from the elements and to provide access for inspection, maintenance, and exercising. Anticipate removal or deployment problems and take suitable precautions.

(2) Take into consideration such environmental conditions as extreme heat or cold; high humidity; blowing sand, dust, or loose debris; soft ground; mud; heavy snows; earthquakes; or combinations thereof, and take adequate precautions.

(3) Establish a fire plan and provide for adequate firefighting equipment and personnel.

*c.* *Maintenance Services and Inspection.*

(1) *Maintenance Services.* Prior to storage, perform the next scheduled unit PMCS.

(2) *Inspection.* Inspect and approve equipment prior to storage. Do not place equipment in storage in a "Non Mission Capable" condition.

*d. Auxiliary Equipment and Basic Issue Items.*

(1) Process auxiliary and basic issue items simultaneously with the major item to which they are assigned. If possible, store auxiliary and basic issue items with the major item.

(2) If stored apart from the major item, mark auxiliary and basic issue items with tags indicating the major item, its registration or serial number and locations, and store in protective type closures.

(3) In addition, place a tag or list indicating the location of the removed items in a conspicuous place on the major item.

*e. Correction of Shortcomings and Deficiencies.* Correct all shortcomings and deficiencies prior to storage, or obtain a deferment from the approving authority.

*f. Lubrication.* Lubricate the equipment in accordance with Section I of Chapter 3.

*g. General Cleaning, Painting, and Presentation.*

### **CAUTION**

**Do not direct pressurized water or steam against air cleaners, exhaust outlets, unsealed electrical systems, fire control instruments, or any exterior opening which will damage a component.**

(1) *Cleaning.* Clean the equipment of dirt, grease, and other contaminants, but do not use vapor decreasing. Remove foreign objects that are wedged between wheels.

(2) *Painting.* Remove rust and damaged paint by scraping, wire brushing, sanding, or buffing. Sand to a smooth finish and spot paint as necessary (TB 43-0209).

(3) *Preservation.* After cleaning and during, immediately coat unpainted metal surfaces with an oil or grease, as appropriate. Use lubricants as approved in Section I of Chapter 3.

### **CAUTION**

**Place a piece of barrier material between desiccant bags and metal surfaces.**

### **NOTE**

**Air circulation under draped covers reduces deterioration from moisture and heat.**

(4) *Weatherproofing.* Sunlight, heat, moisture (humidity), and dirt tend to accelerate deterioration. Install all covers (including vehicle protective closures) authorized for the equipment. Close and secure all openings except those required for venting and draining. Seal openings to prevent the entry of rain, snow, or dust. Insert desiccant when complete seal is required. Place equipment and provide blocking or framing to allow for ventilation and water drainage. Support cover away from item surfaces which may rust, rot, or mildew.

### **4-107. Care of Equipment in Administrative Storage**

*a. Maintenance Services.* After equipment has been in administrative storage, inspect, service, and exercise as specified herein.

*b. Inspection.* Inspection will usually be visual and must consist of at least a walk-around examination of all equipment to observe any deficiencies that may have occurred. Inspect equipment in open storage weekly and that in covered storage monthly. Immediately after any severe storm or environmental change inspect all equipment. The following are examples of things to look for during visual inspection:

- (1) Low or flat tires.
- (2) Condition of preservatives, seals, and wraps.
- (3) Corrosion or other deterioration.
- (4) Missing or damaged parts.
- (5) Water in compartments.
- (6) Any other readily recognizable shortcomings or deficiencies.

*c. Repair During Administrative Storage.* Keep equipment in an optimum state of readiness. Accomplish required services and repairs as expeditiously as possible. Whenever possible, perform all maintenance "on site".

*d. Exercising.* Exercise equipment in accordance with table 4-14, Exercise Schedule; and the following instructions:

(1) *Vehicle Major Exercise.* Depreserve equipment by removing only that material restricting exercise. Close all drains, remove blocks, and perform all before-operation checks. Couple semitrailer to towing vehicle and drive for at least 25 miles. Make several right and left 900 turns. Make several hard braking stops without skidding. Do the following during exercising when it is convenient and safe: operate all other functional components and perform all During and After operation checks.

(2) *Scheduled Services.* Scheduled services will include inspection as described paragraph b, and be conducted in accordance table 4-14. Lubricate in accordance with Section I of Chapter 3.

(3) *Corrective Action.* Immediately take action to correct shortcomings and deficiencies noted. Record inspection and exercise results on DA Form 2404. Record and report all maintenance actions on DA Form 2407. After exercising, restore the preservation to the original condition. Replenish lubricants used during exercising, and note the amount on DA Form 2409-1.

e. *Rotation.* To ensure utilization of all assigned material, rotate items in accordance with any rotational plan that will keep the equipment in an operational condition and reduce the maintenance effort.

**4-108. Procedures for Common Components and Miscellaneous Items**

a. *Tires.* Visually inspect tires during each walk-around inspection of the semitrailer. This inspection includes checking about 5% of the tires, including spare tire, with a tire gage. Inflate, repair, or replace as necessary, those found to be low, damaged, or excessively worn. With a crayon, mark inflated and repaired tires for checking at the next inspection.

b. *Air Lines and Reservoirs.* Drain air lines and reservoirs of condensation, and leave the drain cocks open. Attach a caution tag, annotated to provide for closing of drain cocks when equipment is exercised. Place tags in a conspicuous location.

c. *Seals.* Seals may develop leaks during storage, or shortly thereafter. If leaking persists, refer to the applicable maintenance section in this manual for corrective maintenance procedures.

**4-109. Removal of Equipment from Administrative Storage**

a. *Activation.* Restore equipment to normal operating condition in accordance with the instructions contained in Section I of Chapter 4, Service Upon Receipt of Material.

b. *Servicing.* Resume the maintenance service schedule in effect at the commencement of storage, or service the equipment before the scheduled dates in order to produce a staggered workload.

**4-110. Preparation of Equipment for Shipment**

a. Refer to TM 55-200, TM 55-601, and TM 743-200-1 for additional instructions on processing, storage, and shipment of material.

b. Semitrailers that have been removed from storage for shipment do not have to be reprocessed if they reach their destination within the administrative storage period. Reprocess only if inspection reveals any corrosion, or if anticipated in-transit weather conditions make it necessary.

c. When a semitrailer is received and has already been processed for domestic shipment, as indicated on DD Form 1397, the semitrailer does not have to be reprocessed for storage unless corrosion and deterioration are found during the inspection upon receipt. List all discrepancies found because of poor preservation, packaging, packing, marking, handling, loading, storage, or excessive preservation on SF 364. Repairs that cannot be handled by the receiving unit must have tags attached listing the needed repairs. A report of these conditions will be submitted by the unit commander for action by an ordnance maintenance unit.

**Table 4-14. Exercise Schedule.**

Weeks	2	4	6	8	10	12	14	16	18	20	22	24
PMCS						x						x
Scheduled Services		x		x		x		x		x		
Vehicle Major Exercise												x



**CHAPTER 5  
DIRECT SUPPORT AND GENERAL SUPPORT  
MAINTENANCE INSTRUCTIONS**

**Section I. REPAIR PARTS, SPECIAL TOOLS AND EQUIPMENT**

**5-1. Repair Parts**

Repair parts required for direct support and general support maintenance of the M967, M967A1, M969, M969A1, M970, and M970A1 semitrailers are listed and illustrated in TM 9-2330-356-24P.

support and general support to maintain the semitrailers. Additional information for special tools is contained in TM 9-2330-356-24P.

**5-2. Special Tools and Equipment**

Table 5-1 contains a list of all special tools, components of tool sets, and test and support equipment needed by direct

**5-3. Fabricated Tools and Equipment**

Table 5-2 contains fabrication instructions for all tools which must be made by direct support or general support personnel for maintenance of the semitrailers. Table 5-3 contains information on fabricated tube lines required by direct support and general support maintenance.

**Table 5-1. Special Tools, Test, and Support Equipment.**

Item	NSN or Reference No.	Reference		Use
		Fig. No.	Para. No.	
Puller, flywheel and sprocket	5120-00-613-8775 11671732 (1 9207)	7-22	7-27	Remove flywheel and sprocket from crankshaft
Compression tool, plunger spring	5180-01-048-8603 TSE-76215 (01843)	747	7-69	Remove end install spring seat
Test fixture, delivery valve	5180-01-048-8602 TSE-76226 (01 843) or equivalent	748	7-69	Testing fuel injection pump delivery valve
Centering sleeve	2910-00-448-0197 TSE-773 (01 843)	7-53	7-70	Assembly of fuel injector
Gage, compression tester	4910-00-870-6283 10899180 (19207)	7-25	7-89	Testing cylinder compression
Adapter, compression tester	4910-00-019-5241	7-25	7-89	On engine
Driver, valve seat	4820-01-284-2153 420-0270 (44940)	7-56	7-72	installation of valve seats in engine head
Driver, valve guide	5120-01-033-7505 420-0300 (44940)	7-55	7-72	Removal and installation of valve guides
Remover, valve	3450-01-014-0788 420-0311 (44940)	7-57	7-72	Removal of valve seats
Driver, oil seal	5120-01-008-3863 420-0281 (44940)	7-28	7-75	Installation of gear cover oil seal
Driver, bearing	5120-00-125-4402 420-0326 (44940)	7-36 7-34	7-40 7-38	Installation of crankshaft and camshaft bearings
Puller ring, gear	5120-01-014-0903 420-0275 (44940)	7-33	7-36	Removal of gear from crankshaft
Driver, oil seal	5120-00-125-4411 420-0250	7-34	7-77	Remove and install oil seal on rear of crankshaft

Table 5-2. Fabricated Tools and Equipment.

Item	NSN or Reference No.	Reference		Use	Material Required
		Fig. No.	Para. No.		
Pump mounting fixture	-	-	7-69	Mount fixture for fuel injection pump	0.375" hot rolled steel

Fabrication Instructions:

Fabricate fixtures as shown below. Drill "F" (0.255 in.-0.262 in.) depth through countersink 60° incl. to 0.332 in. diameter. Tap 0.3125-18 UNC-2B depth through two holes located within 0.005 in. of true position.

Sketch or Diagram:

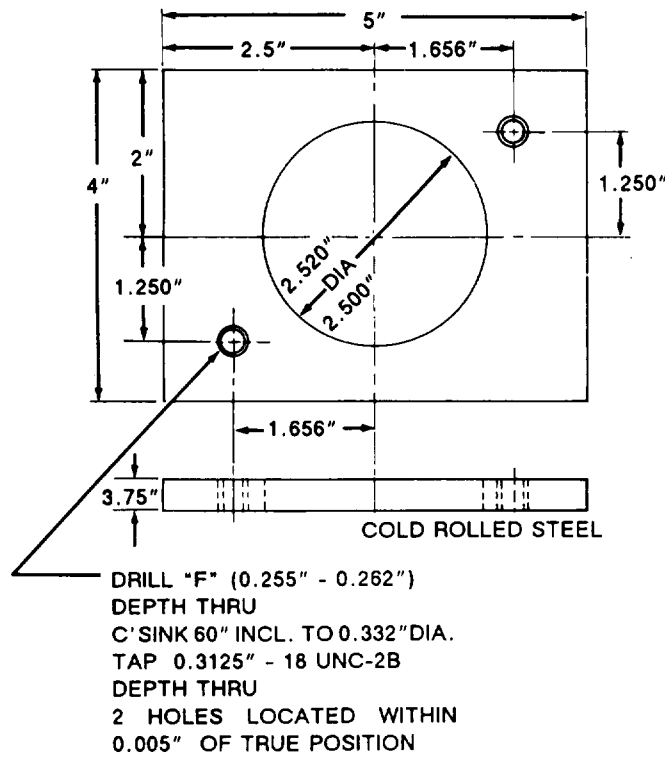

TA502297

Table 5-2. Fabricated Tools and Equipment (Con't).

Item	NSN or Reference No.	Reference		Use	Material Required
		Fig. No.	Para. No.		
Crankshaft gear driver	-	-	7-38	Installation of crankshaft gear thickness	Steel pipe 3/16" wall

Fabrication Instructions:

Make driver according to dimensions shown.

**Table 5-2. Fabricated Tools and Equipment (Con't).**

Sketch or Diagram:

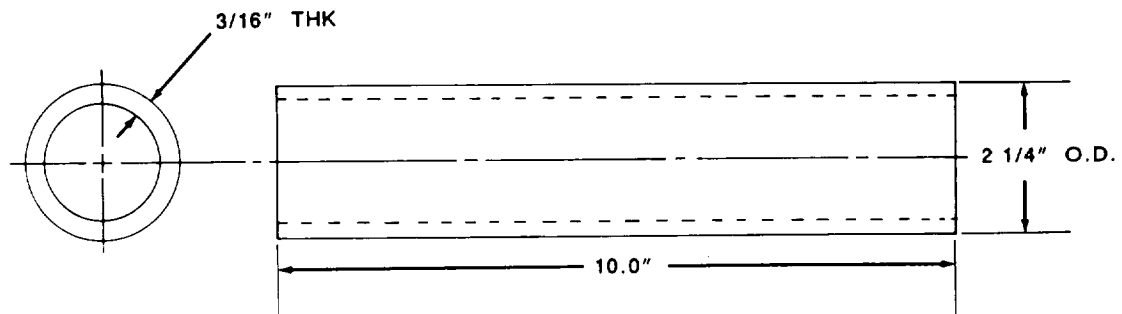

TA502298

**Table 5-3. Fabricated Tube Lines.**

Part No.	Bulk Part No.	Bulk Tubing Dia.	Length
11670916-1	CPR 104420-1	1/4"	60"
11670916-2	CPR 104420-2	3/8"	60"
11670916-3	8360440	5/8"	40"

**Section II. DIRECT SUPPORT AND GENERAL SUPPORT TROUBLESHOOTING**

**5-4. General**

a. This section contains troubleshooting information for locating and correcting most of the troubles which may develop in the semitrailers. Each malfunction for an individual component, unit, or system is followed by a list of tests or inspections which will help you to determine corrective actions to take. You should perform the test/inspections and corrective actions in the order listed.

b. This manual cannot list all malfunctions that may occur, nor all tests and inspections and corrective actions. If a malfunction is not listed or is not corrected by listed corrective actions, notify your supervisor.

c. Ensure that all safety precautions listed in the Warning Summary are followed while performing troubleshooting. Pay close attention to all WARNINGS and CAUTIONS.

**5-5. Use**

a. Information in this section is for use by direct support and general support personnel.

b. Tables 5-4 and 5-5 are to be used in conjunction with and as a supplement to Operator Troubleshooting (table 3-2) and Unit Troubleshooting (table 4-9), located elsewhere in this manual.

**5-6. Procedures and Instructions**

**NOTE**

**Before you use the troubleshooting tables, ensure that you have performed all applicable operational checks.**

a. Tables 5-4 and 5-5 include procedures for on-equipment tests and inspections, and for testing the component or assembly after it has been removed from the semitrailer.

b. Visual inspections are to be made before operating the equipment or performing any functional tests. The purpose of these inspections is to determine the condition of the component or assembly for obvious indications of damage. If damage is evident, corrective action shall be taken to prevent further damage.

c. Inspections and tests performed after the component or assembly has been removed from the semitrailer are to verify the original diagnosis and to uncover further defects.

d. Complete disassembly of a component or assembly to determine the cause of malfunction should be done only if the preliminary tests fail to show the trouble. A careful inspection of the component parts should then be made to pinpoint the problem. An analysis of the damaged part should also be made to determine if corrective action, other than replacing the damaged part, can be taken to prevent recurrence of the problem.

**Table 5-4. Troubleshooting - Direct Support**

---

**MALFUNCTION**

**TEST OR INSPECTION**

**CORRECTIVE ACTION**

---

**BRAKE SYSTEM**

**1. RAPID BRAKE LINING WEAR.**

Step 1. Check the linings to ensure that the correct linings are being used. Combination linings should not be used.

Install correct linings on brake shoes (para 6-6).

Step 2. Inspect brake drums for scoring, cracks, or uneven wear.

If brake drum is cracked or badly damaged, it must be replaced. If scoring is less than 1/16-inch deep, the brake drum can be rebored (para 6-7).

---

**ENGINE**

**2. STARTER MOTOR DOES NOT TURN - HIGH CURRENT DRAW.**

Step 1. Check starter for grounded switch, terminals, or field (para 7-90)

Replace grounded component.

Step 2. Check for frozen armature shaft bushing (para 7-90).

Replace bushing. Replace starter if necessary.

**3. STARTER DOES NOT TURN - NO CURRENT DRAW.**

Step 1. Check for open armature windings (para 7-90).

Replace starter.

Step 2. Check for open starter field windings (para 7-90).

Replace starter.

Step 3. Check for broken or weak brush springs (para 7-78 or 7-90),

Replace brush springs if necessary.

Step 4. Check for worn commutator (high mica) (para 7-78).

Replace starter.

*Table 5-4. Troubleshooting - Direct Support (Con't).***MALFUNCTION****TEST OR INSPECTION****CORRECTIVE ACTION****ENGINE (Con't)****4. SLOW STARTER SPEED.**

Step 1. Check for worn armature shaft bushings (para 7-78).

Replace bushings. Replace starter if necessary.

Step 2. Check for burned solenoid contacts (para 7-78).

Replace solenoid.

Step 3. Check for open or shorted field windings (para 7-90).

Replace starter.

Step 4. Check for worn engine crankshaft, rod, and camshaft bearings (para 7-77).

Replace bearings as necessary. Repair or replace other worn components as necessary.

**5. STARTER WILL NOT ENGAGE FLYWHEEL.**

Step 1. Check starter clutch (bendix) and pinion (para 7-78).

Repair or replace as necessary.

Step 2. Check for damaged ring gear (para 7-78).

Replace ring gear if necessary.

**6. ENGINE WILL NOT START WHEN CRANKED.**

Step 1. Check for faulty injection caused by dirty fuel.

Replace with clean fuel. Service fuel filters. Clean and, if necessary, repair or replace fuel injection nozzle (paras 7-28 and 7-70).

Step 2. Check for poor compression.

See Malfunction 15, *LOW ENGINE COMPRESSION*.

Step 3. Check for incorrect timing.

Retime engine (para 7-87).

**7. ENGINE MISFIRES.**

Step 1. Check for poor compression.

See Malfunction 15, *LOW ENGINE COMPRESSION*.

Step 2. Check for defective or dirty injection nozzles (para 7-70).

Clean or replace nozzles.

*Table 5-4. Troubleshooting - Direct Support (Con't).*

---

MALFUNCTION	TEST OR INSPECTION	CORRECTIVE ACTION
-------------	--------------------	-------------------

---

**ENGINE (Con't)**

**7. ENGINE MISFIRES (Con't).**

- Step 3. Check for faulty injection pump or nozzles (para 7-87).  
 Repair, overhaul, rebuild, or replace pump and nozzles as necessary.
- Step 4. Check for broken valve spring (para 7-72).  
 Replace broken springs.
- Step 5. Check cylinder head assembly for build-up of carbon (para 4-73).  
 Clean carbon from cylinder head assembly.

**8. LOW ENGINE POWER.**

- Step 1. Check for poor compression.  
 See Malfunction 15, *LOW ENGINE COMPRESSION*.
- Step 2. Check for incorrect timing.  
 Retime engine (para 7-87).

**9. LOW OIL PRESSURE.**

- Step 1. Check to see if oil bypass valve is stuck open (para 7-74).  
 Clean or replace oil bypass valve and spring.
- Step 2. Check for worn oil pump (para 7-35).  
 Replace oil pump.
- Step 3. Suspect worn engine bearings (para 7-77).  
 Notify general support maintenance personnel.

**10. HIGH OIL PRESSURE.**

- Step 1. Check to see if oil bypass valve is stuck closed (para 7-74).  
 Clean or replace oil bypass valve and spring.
- Step 2. Check for clogged oil passages.  
 Clean all oil lines and passages.

**11. EXCESSIVE OIL CONSUMPTION.**

Suspect worn valve guides, bad seals in crankcase, sticking or worn piston rings. Notify general support maintenance personnel.

*Table 5-4. Troubleshooting - Direct Support (Con't).*

---

**MALFUNCTION**

**TEST OR INSPECTION**

**CORRECTIVE ACTION**

---

**ENGINE (Con't)**

**12. BLACK SMOKEY EXHAUST AND EXCESSIVE FUEL CONSUMPTION.**

- Step 1. Check for incorrect timing (para 7-87).  
Retime engine.
- Step 2. Suspect bad valves.  
Notify general support maintenance personnel.

**13. TAPPING OR CLICKING SOUND FROM CYLINDER HEAD.**

- Step 1. Check for too great a valve clearance (para 7-88).  
Adjust rocker arm to valve clearance.
- Step 2. Check for broken valve spring (para 7-72).  
Replace broken springs.

**14. METALLIC KNOCKING, CLICKING, OR POUNDING FROM CRANKCASE OR CYLINDER BLOCK.**

Suspect loose bearings on connecting rods, or loose pistons. Notify general support maintenance personnel.

**15. LOW ENGINE COMPRESSION.**

- Step 1. Check for loose cylinder head (para 7-72).  
Properly tighten head.
- Step 2. Check for leaky head gasket (para 7-72).  
Replace gasket.
- Step 3. Check for broken valve spring (para 7-72).  
Replace broken springs.
- Step 4. Suspect bad valves, piston rings, or scored cylinder walls.  
Notify general support maintenance personnel.

---

**ALTERNATOR AND CHARGING CIRCUIT**

**16. UNDERCHARGED BATTERIES.**

- Step 1. Check for moisture or dirt on top of batteries causing continuous battery discharge.  
Clean the batteries (para 4-23).

*Table 5-4. Troubleshooting - Direct Support (Con't).*

---

<b>MALFUNCTION</b>	<b>TEST OR INSPECTION</b>	<b>CORRECTIVE ACTION</b>
--------------------	---------------------------	--------------------------

---

**ALTERNATOR AND CHARGING CIRCUIT (Con't)**

**16. UNDERCHARGED BATTERIES (Con't).**

- Step 2. Check for loose or corroded battery terminals and connections, or bad battery.  
Clean and tighten battery connections. Test battery (para 4-23).
- Step 3. Look for worn or glazed pulley or loose belts on alternator drive.  
Adjust tension on alternator drive belt (para 4-78). Replace pulley if worn or glazed.
- Step 4. Check for excessive voltage drop between alternator and batteries (para 7-91).  
Clean and tighten connections at positive and negative output terminals on alternator (para 7-91). Also check connections at buss bar assembly and ground (wire No. 3) on engine (fig. 4-28 or 4-29).
- Step 5. Check engine wiring, especially wire No. 6 (from buss bar to starter solenoid and from buss bar to engine junction box), for damage (fig. 4-28 or 4-29).  
Replace damaged wire.
- Step 6. Check for low setting on voltage regulator (para 7-91).  
Adjust voltage regulator.
- Step 7. Check for low alternator output (para 7-91).  
Repair or replace alternator.

**NOTE**

**Small current draw (90 milliamps) through field circuit when engine is not running is normal. This is the bleed circuit built into the voltage regulator.**

- Step 8. Test for leaking positive rectifier causing field current draw (2-4 amps) when engine is not running.  
Replace diode trio (para 7-79).
- Step 9. Check for faulty voltage regulator (para 7-91).  
Replace voltage regulator.

**17. OVERCHARGED BATTERIES (Indicated by high water usage).**

- Step 1. Check battery case for cracks or damage (para 4-23).  
Replace damaged battery.
- Step 2. Check specific gravity or voltage of individual cells (para 4-23).  
Replace defective battery.



*Table 5-4. Troubleshooting - Direct Support (Con't).*

---

**MALFUNCTION****TEST OR INSPECTION****CORRECTIVE ACTION**

---

**ALTERNATOR AND CHARGING CIRCUIT (Con't)****17. OVERCHARGED BATTERIES (Indicated by high water usage) (Con't).**

Step 3. Test for high voltage regulator setting or faulty voltage regulator (para 7-91 ).

Adjust voltage to proper setting (para 7-91). Replace voltage regulator if voltage setting cannot be lowered,

**18. LOW ALTERNATOR OUTPUT.**

Step 1. Perform "full field" test to determine if problem is in alternator or voltage regulator (para 7-91).

If voltage does not increase noticeably (.3V or more) during test, alternator is faulty and should be repaired or replaced.

Step 2. If voltage increased noticeably during test in Step 1, the problem is either in the diode trio or the voltage regulator. Remove diode trio and test for proper functioning (para 7-91).

Replace diode trio if test shows one of the diodes is faulty.

Step 3. Remove and inspect voltage regulator. Check for printed circuit path that has burned open (para 7-91).

Replace voltage regulator.

**19. SHORT LIFE OF VOLTAGE REGULATOR.**

Step 1. Check that alternator and battery connections are correct. Reversing polarity, even momentarily, will damage the voltage regulator.

Notify operator and unit maintenance personnel about proper procedures.

Step 2. Inspect voltage regulator before installation for defects or damage in shipment or handling.

Replace voltage regulator if damaged or defective.

**20. NOISY ALTERNATOR.**

Step 1. Check for loose pulley or mounting bolts (para 4-78).

Tighten mounting bolts and alternator drive pulley.

Step 2. Check for worn or sticking bearings by removing alternator drive belt and rotating alternator by hand (para 4-78 or 6-20).

Repair or replace alternator.

---

*Table 5-5. Troubleshooting - General Support.*

MALFUNCTION	TEST OR INSPECTION	CORRECTIVE ACTION
<b>ENGINE</b>		
<b>1. EXCESSIVE OIL CONSUMPTION.</b>		
	Step 1. Check for worn valve guides (para 7-72).	Replace guides, valves, and seals.
	Step 2. Check for worn or sticking piston rings (para 7-31).	Replace rings if necessary.
	Step 3. Check for air leaks to crankcase.	Replace gaskets and seals as necessary.
<b>2. METALLIC KNOCKING, CLICKING, OR POUNDING FROM CRANKCASE OR CYLINDER BLOCK.</b>		
	Step 1. Check for worn or loose connecting rod bearings (para 7-31.).	Replace bearings if necessary.
	Step 2. Check for loose piston and connecting rod assembly (para 7-31).	Repair or replace assembly.
<b>3. LOW ENGINE COMPRESSION.</b>		
	Step 1. Check for sticking valves (para 7-72).	See Malfunction 4, <i>STICKING VALVES</i> .
	Step 2. Check for leaking valves (para 7-72).	Clean and, if necessary, regrind valves and valve seats.
	Step 3. Check for worn or sticking piston rings (para 7-31).	Replace rings if necessary. Check condition of cylinder walls.
	Step 4. Check for worn cylinder walls and pistons (para 7-31).	Refinish cylinder walls. Repair or replace pistons.
<b>4. STICKING VALVES.</b>		
	Step 1. Check for dirty, scored, or gummy valve stems or guides (para 7-72).	
	Step 2. Check for weak or broken springs (para 7-72).	Replace springs.
	Step 3. Check clearance between valve stem and guide (para 7-72).	Correct clearance.

### Section III. GENERAL MAINTENANCE

#### 5-7. General Maintenance

a. This section contains general maintenance instructions which are the responsibility of direct support and general support maintenance personnel. These instructions pertain to several components or assemblies and otherwise would need to be repeated several times throughout the chapters. Special information on general repair practices, parts replacements, welding, riveting, and tools are also included.

b. Ensure that all safety precautions listed in the Warning Summary are followed while performing maintenance. Pay close attention to all WARNINGS and CAUTIONS.

#### 5-8. General Maintenance Procedures

##### a. *Work Area.*

(1) Make sure the work area is clean before you disassemble the pump or engine.

(2) Make sure that materials needed for the maintenance task are at hand. These may include cleaning solvents, lubricants, buckets, or other containers for cleaning or keeping components separated, clean wiping cloths, and the proper tools.

##### b. *Cleaning of Components, Assemblies or Parts.*

(1) Clean the exterior of the component or assembly before disassembly to keep foreign matter from bearings, gears, and other machine-surfaced parts which are subject to scoring and other such damage.

#### WARNING

**Compressed air used for drying or cleaning purposes must not exceed 30 psi (207 kPa). Wear protective clothing (goggles and gloves) and use caution to avoid Injury to personnel.**

(2) If compressed air is used to clean parts, you should make sure it is free of dirt and other contaminants.

(3) Protect disassembled parts from dust, blowing sand, and moisture which can cause rapid wear and deterioration of bearings, gears, and other machine parts.

##### c. *General Instructions.*

(1) In disassembly, remove only as many parts or components as required for indicated repair. Complete disassembly of a component is not always required to make repairs. Good judgement should be used to keep disassembly operations to a minimum.

(2) During disassembly, tag critical parts to ensure proper reassembly. Mark mating parts by scribe marks or indelible ink to be certain of correct positioning at assembly.

(3) Unserviceable or unrepairable assemblies will be broken down into items of issue, and serviceable parts will be returned to stock. Parts or assemblies which cannot be repaired, selective-fitted, or reclaimed to standards contained in this manual, will be salvaged and replaced with new parts.

(4) If a required new part is not available, reconditioning of the old part is necessary. Such parts should be inspected carefully after reconditioning to determine their suitability and probable service life. Replacement parts should be requisitioned immediately.

(5) Replace seals and gaskets of all components disassembled.

(6) Replace springs if broken, distorted, or cracked, or if they do not conform to specific tensile standards.

(7) Replace screws or nuts with damaged threads or rounded comers. Replace lockwashers.

(8) Replace keys if damaged.

(9) During assembly, subassemblies should be assembled first. The subassemblies can then be combined into major components and installed to make a complete major assembly.

d. *Care of Bearings.*

**WARNING**

- **Dry cleaning solvent P-D-680 is toxic and flammable. Always wear protective goggles and gloves, and use only in a well-ventilated area. Avoid contact with skin, eyes, and clothes, and DO NOT breathe vapors. DO NOT use near open flame or excessive heat. The solvent's flash point is 100°F-138°F (38°C-59°C). If you become dizzy while using cleaning solvent, immediately get fresh air and medical help. If solvent contacts eyes, immediately wash your eyes with water and get medical aid.**
- **Compressed air used for drying or cleaning purposes must not exceed 30 psi (207 kPa). Wear protective clothing (goggles and gloves) and use caution to avoid injury to personnel.**

**NOTE**

**Refer to TM 9-214 for further information on the inspection, care, and maintenance of bearings.**

(1) Clean ball and roller bearings by placing them in a wire basket and immersing in a container of fresh dry cleaning solvent (item 11, Appendix E). Agitate the bearings in the solvent to remove all traces of old lubricant.

(2) After cleaning the bearings, dry them with clean compressed air. Take care to prevent spinning the bearings when using a compressed air jet.

(3) Dip the cleaned bearings in clean engine oil and immediately wrap them in a lint-free cloth (item 24, Appendix E) to protect them from dust and other foreign matter.

**5-9. Specific Procedures**

a. *Welding.*

(1) Refer to TM 9-237 for welding instructions and materials. All welds must reflect good workmanship and approved welding procedures. Welds must be secure, free from cracks, excessive spatter, and obvious defects.

(2) Read and observe all safety precautions in the Warning Summary before performing any welding operation.

b. *Surface Protection.*

(1) Clean and repaint all surfaces on which paint has deteriorated or become damaged.

(2) Do not paint grounding studs or electrical harnesses or leads.

(3) Paint exterior of vehicle olive drab in accordance with TT-E-529 or TT-E-485.

c. *Repairing Damaged Threads.*

(1) When determined feasible by inspection, damaged threads should be repaired by retapping, by use of a thread die or a thread restorer file.

(2) Tapped holes for screw thread inserts that have mutilated threads may be repaired by:

(a) Drilling and tapping holes oversize, then installing larger screws.

(b) Filling tapped hole by welding, then re-drilling and tapping hole to original size.

d. *Removing Burrs, Scratches, and Raised Metal.*

**WARNING**

**Dry cleaning solvent P-D-680 is toxic and flammable. Always wear protective goggles and gloves, and use only in a well-ventilated area. Avoid contact with skin, eyes, and clothes, and DO NOT breathe vapors. DO NOT use near open flame or excessive heat. The solvent's flash point is 100°F-138°F (38°C-59°C). If you become dizzy while using cleaning solvent, immediately get fresh air and medical help. If solvent contacts eyes, immediately wash your eyes with water and get medical aid.**

(1) Use fine mill file, soft stone, or crocus cloth (item 4, Appendix E) dipped in dry cleaning solvent (item 11, Appendix E) to remove burrs, scratches, or raised metal.

(2) When filing aluminum, clean file often with steel file brush to avoid loading file with aluminum particles which will gouge work surface.

e. *Cleaning Materials and Methods.***WARNING**

**Dry cleaning solvent P-D-680 is toxic and flammable. Always wear protective goggles and gloves, and use only in a well-ventilated area. Avoid contact with skin, eyes, and clothes, and DO NOT breathe vapors. DO NOT use near open flame or excessive heat. The solvent's flash point is 100°F-138°F (38°C-59°C). If you become dizzy while using cleaning solvent, immediately get fresh air and medical help. If solvent contacts eyes, immediately wash your eyes with water and get medical aid.**

(1) Refer to TM 9-247 for cleaning materials to be used.

(2) Cleaning is normally done by the dip-tank and/or vapor-degreaser methods, or by cleaning with cloths soaked in dry cleaning solvent (item 11, Appendix E).

f. *Cleaning of Material Received From Storage.***WARNING**

**Dry cleaning solvent P-D-680 is toxic and flammable. Always wear protective goggles and gloves, and use only in a well-ventilated area. Avoid contact with skin, eyes, and clothes, and DO NOT breathe vapors. DO NOT use near open flame or excessive heat. The solvent's flash point is 100°F-138°F (38°C-59°C). If you become dizzy while using cleaning solvent, immediately get fresh air and medical help. If solvent contacts eyes, immediately wash your eyes with water and get medical aid.**

(1) Material received from storage by direct and general support maintenance units will be cleaned by the dip-tank, vapor-degreaser, or steam method; whichever is applicable or available. Descriptions of these methods are as follows:

(a) *Dip-tank Method.* Disassemble as required and place parts in a perforated metal basket.

Submerge and agitate the basket in a tank containing dry cleaning solvent (item 11, Appendix E). Repeat, using a second tank with clean solvent. Extent of treatment in each tank will depend on ease with which parts are cleaned.

(b) *Vapor-degreaser Method.* Tanks containing a heated solution of trichlorethylene or perchlorethylene (type 11) are used for decreasing items that are very greasy or oily and are not readily cleaned by the dip-tank method. Place parts in a perforated metal basket and submerge below the vapor in the tank. Keep the basket in this position until all the grease, oil, or dirt melts and runs off the parts. If necessary, material may be washed with decreasing spray unit.

(c) *Steam Method.* Place parts in a perforated metal basket and steam treat until clean. This method is less efficient than the vapor-degreaser method, and parts may require additional cleaning to remove final traces of grease, oil or dirt, particularly from recesses.

(2) If some time is to elapse before the start of repair or overhaul operations, apply a coat of light grade PE-10 preservative oil to all finished metal surfaces to prevent rusting.

**WARNING**

**Compressed air used for drying or cleaning purposes must not exceed 30 psi (207 kPa). Wear protective clothing (goggles and gloves) and use caution to avoid injury to personnel.**

g. *Cleaning After Shop Inspection.* After inprocess shop inspections, dip parts in a tank containing fingerprint remover oil (item 9, Appendix E). Remove parts (with rubber gloves), and dry thoroughly with compressed air or by wiping with clean, lint-free cloths (item 24, Appendix E). Apply preservatives as soon as possible after cleaning.

h. *Lubrication.* Refer to Chapter 3, Section I for lubrication instructions.

i. *Installation of Split Couplings.* When installing couplings and gaskets, use the procedure described in paragraph 4-85.

**Section IV. REMOVAL AND INSTALLATION OF MAJOR COMPONENTS**

**5-10. Upper Coupler (Kingpin) Plate Replacement (Later Models) (Fig. 5-1)**

*a. Removal.*

- (1) Provide a balanced support for upper coupler plate (4).
- (2) Remove twelve locknuts (1), bolts (3), and washers (2). Discard locknuts.
- (3) Remove upper coupler plate (4) from under semitrailer.

*b. Installation.*

- (1) Place upper coupler plate (4) on a suitable support.
- (2) Lift upper coupler plate (4) into position under semitrailer. Loosely install twelve bolts (3), washers (2), and new locknuts (1).
- (3) Ensure that upper coupler plate (4) is flush against semitrailer. Tighten twelve locknuts (1) to 130-140 lb.-ft.
- (4) Lubricate upper coupler plate (4) (Chapter 3, Section I).

**5-11. Torque Rods (Upper and Lower) M967, M969, and M970 except 970 SN TC-0843, TC-0844, and TC-103 thru TC-178) (Fig. 5-2).**

*a. Removal.*

- (1) Remove cotter pins and slotted nuts from threaded end of ball assemblies.
- (2) Tap threaded end of ball assembly with a soft hammer to loosen ball assembly from bracket.
- (3) Use a crowbar or cold chisel to pry the torque rod from the brackets. The ball assemblies are mounted in robber and can be moved out of normal alignment for removal or installation.

*b. Installation.*

- (1) Insert threaded end of ball assembly in hole of bracket on the bogie assembly. Using torque rod as a lever, bend the ball assembly out of normal alignment so ball assembly on other end is near the hole in the axle bracket.
- (2) Use a crowbar or cold chisel to bend the ball assembly so it can be pushed into hole in axle bracket. Use care not to damage the ball assembly.
- (3) Install slotted nuts on lower torque rod and tighten to 350-400 lb.-ft.
- (4) Install cotter pins to secure the slotted nuts.

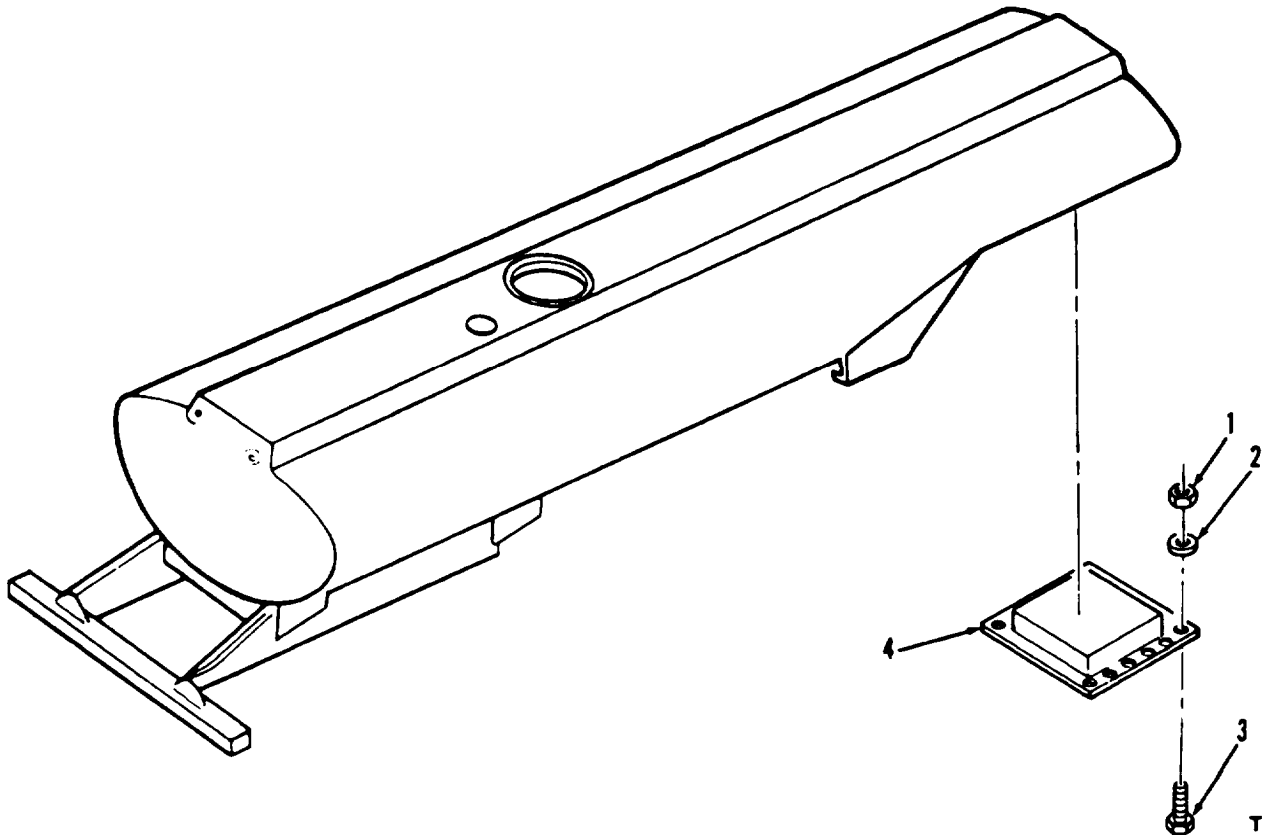

TA502299

*Figure 5-1, Upper Coupler (Kingpin) Plate (Later Models)*

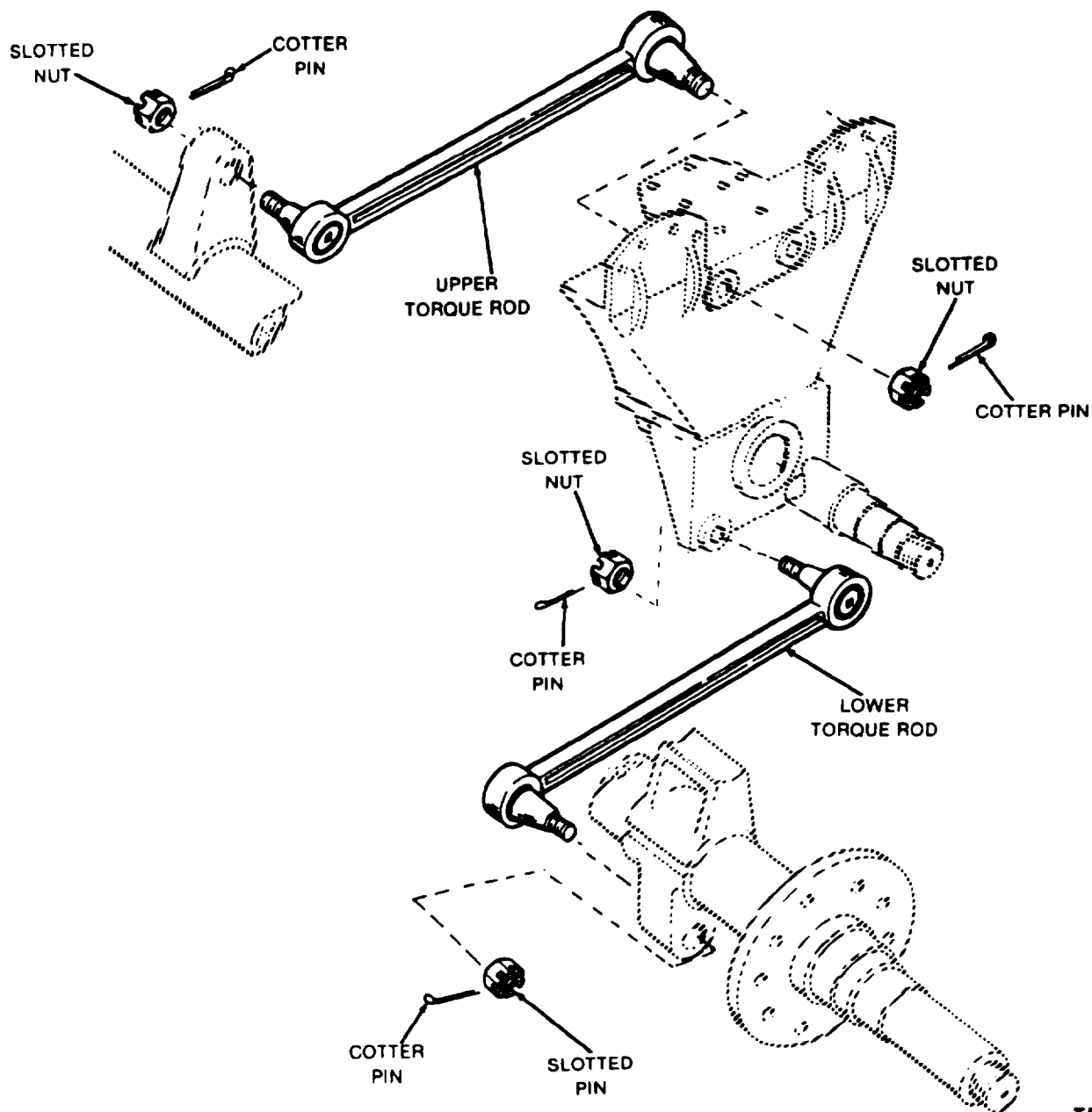

TA100050

**Figure 5-2. Upper and Lower Torque Rods (M967, M969, and M970 except M970 SN TC-0843, TC-0844, and TC-103 thru TC-178).**

**5-12. M970 except M970 SN TC-0843, TC-0844, and TC-103 thru T-178).**

*a. Removal (Figs. 5-3 and 5-4).*

(1) Position semitrailer on hard level surface with front resting on landing gear.

(2) Jack up the front and rear axles on the side where the spring is to be removed until wheels are approximately 1-inch off the ground. The jacks should be

positioned as close as possible to the lower torque rod brackets on the axles.

(3) Position a jack under the torque rod bracket on the trunnion cross tube. Jack up the trunnion cross tube until the weight of the vehicle is removed from the spring to be removed. Put supports or cribbing under the rear corners of the semitrailer frame.

(4) Remove wheels from both axles (para 4-49).

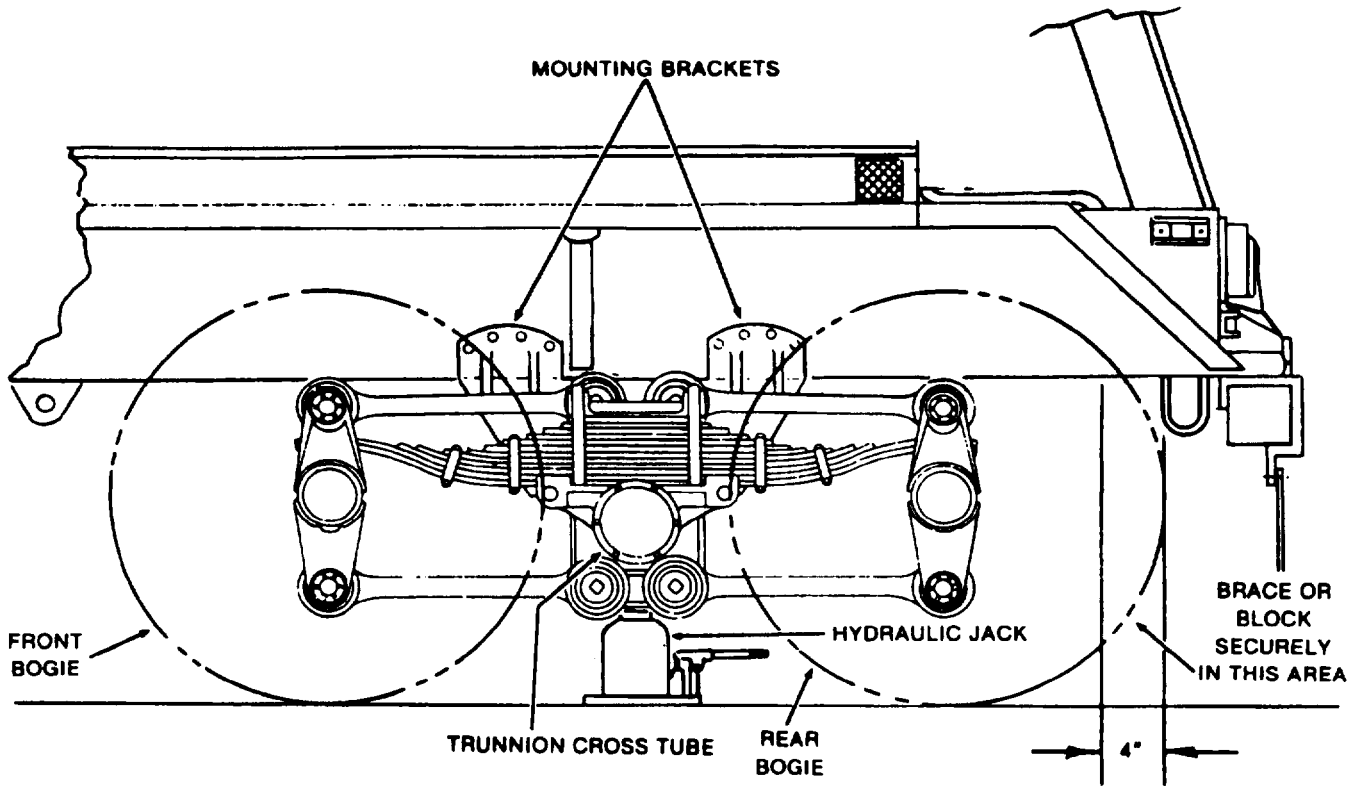

Figure 5-3. Suspension Assembly (M967, M969, and M970 except M970 SN TC-0843, TC-0844, and TC-103 thru TC-178).

TA100051

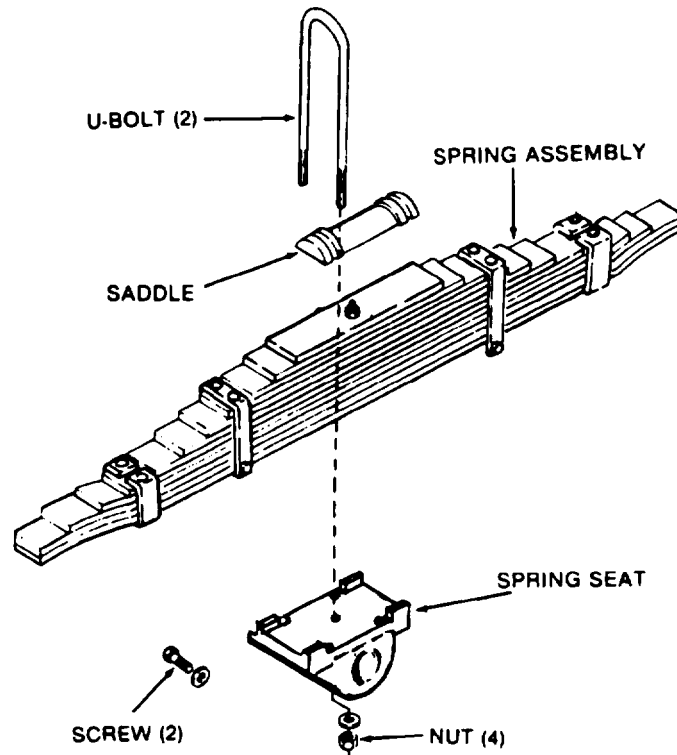

Figure 5-4. Suspension Spring (M967, M969, and M970 except M970 SN TC-0843, TC-0844, and TC-103 thru TC-178).

TA100052



**WARNING**

**Release air pressure from both air reservoirs before doing any work on brake lines or other pressurized air lines.**

(5) Release air from both air reservoirs by opening drain cocks on bottom of reservoirs (fig. 4-79). Tag and disconnect the four hoses from brake chambers on both axles on side which is raised to allow for removal of the spring assembly.

**WARNING**

**If spring assembly is seized in spring seat, jack the rear axle higher to lift the spring. Be careful not to lift semitrailer off the supports under the frame.**

(6) Remove four nuts and washers from the two U-bolts. Remove the U-bolts and spring saddle. Loosen two screws which clamp the spring assembly in the spring seat. Pry spring assembly from spring seat.

(7) Disconnect upper torque rod (para 5-11) from rear axle and revolve the axle rearward to allow for removal of the spring.

(8) Use a lifting device to lift the spring from the spring guide bracket on the axle, and remove it from the semitrailer.

*b. Installation (Figs. 5-3 and 5-4).*

(1) Lubricate the spring bearing plate. Insert end of spring, larger leaf down, into spring guide bracket on forward rudd.

(2) Position spring on spring seat so center, bolt of spring is over recess in spring seat. Press or drive the spring into place. Ensure that the spring center bolt is in the recess and the spring is firmly seated.

(3) Put the spring saddle in position on the spring. The nut on the center bolt fits into the recess on the saddle. Install U-bolts over saddle and through holes in spring seat. Install four washers and nuts on U-bolts and tighten evenly to 200-320 lb.-ft. Tighten the two screws which clamp the spring to the spring seat to 650-750 lb.-ft.

(4) Using jacks under rear axle, revolve the rudd rearward so end of spring will enter guide bracket on axle. Release jacks after spring clears the guide bracket.

(5) Connect the upper torque rod to bracket on rear axle (para 5-11).

(6) Connect four hoses to broke air chambers as tagged.

(7) Install wheels (pars 4-49).

(8) Remove supports and jacks.

**5-13. Suspension M967A1, M969A1, and M970A1 including M970 SN TC-0843, TC-0844, and TC-103 thru TC-178).**

*a. Removal (Fig. 5-5).*

(1) Position semitrailer on hard level surface with front resting on landing gear.

**WARNING**

**Release air pressure from both air reservoirs before doing any work on brake lines or other pressurized air lines.**

(2) Release air from both air reservoirs by opening drain cocks on bottom of reservoirs (fig. 4-79).

(3) Loosen wheel lug nuts while wheels are on ground.

(4) Jack up rear of semitrailer and support under frame securely until weight of semitrailer is removed from springs and axles.

(5) Remove wheels from both axles (pars 4-49).

(6) Remove both axles (para 5-15).

(7) Position a jack under the trunnion tube close to the inside of each trunnion hanger.

(8) Raise jacks just enough to support trunnion tube.

(9) Remove four nuts, four washers, and four bolts which fasten the trunnion hanger to the mounting bracket. Repeat for opposite side.

(10) Slowly lower suspension and support trunnion tube.

*b. Disassembly (Fig. 5-5).*

(1) Use lifting device to support spring.

(2) Remove four nuts and four washers from u-bolts.

(3) Remove two U-bolts and wear plate.

(4) Using lifting device, lift spring from upper trunnion hub and remove it from the suspension.

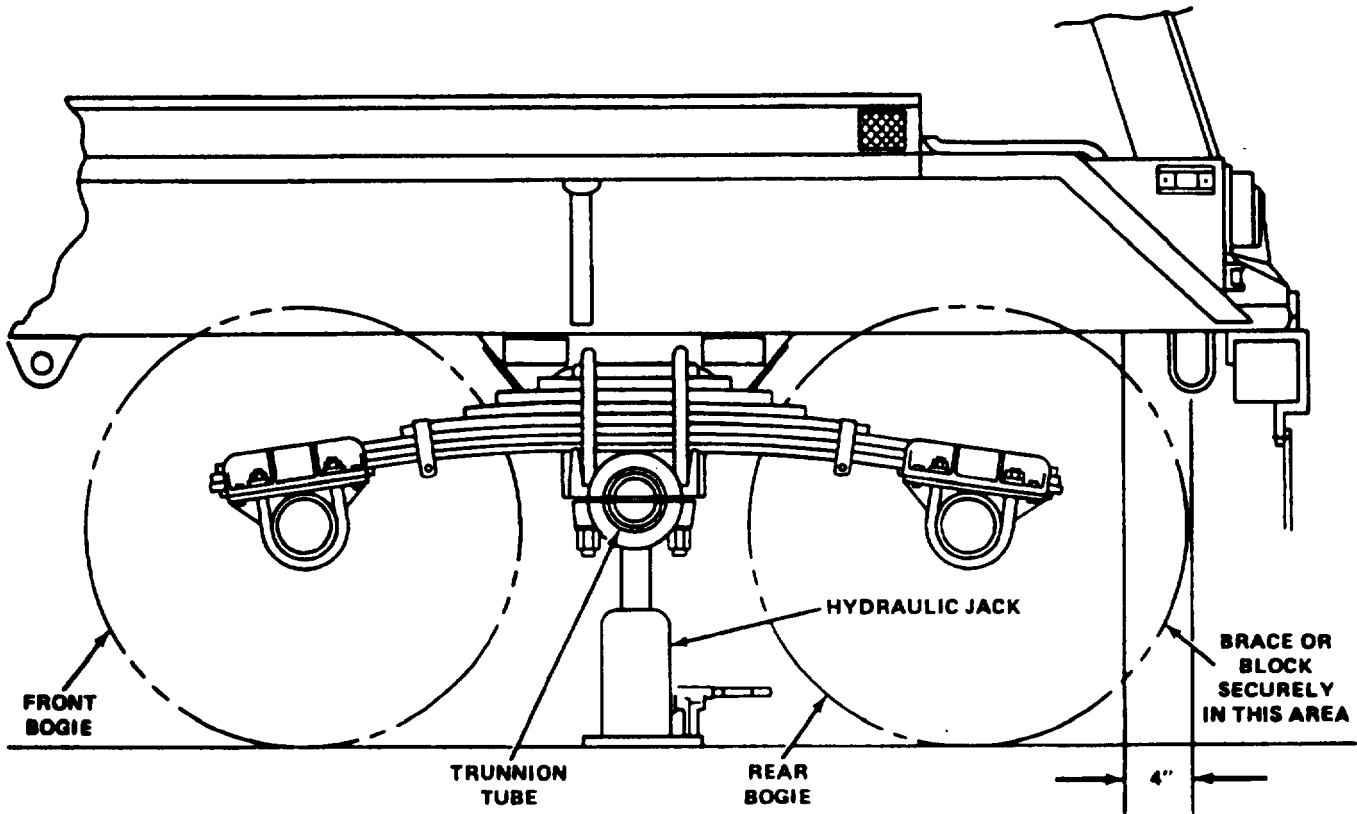

*Figure 5-5. Suspension Assembly (M967A1, M969A1, and M970A1 including M970 SN TC-0843, TC-0844, and TC-103 thru TC-178).*

(5) Remove upper and lower trunnion hubs and trunnion tube.

(6) Remove rubber bushing and trunnion washer from trunnion tube.

(7) Loosen two trunnion hanger capscrews and nuts, and slide hanger off trunnion tube.

(8) Repeat steps (1) through (7) for opposite side.

c. Assembly.

(1) Slide trunnion hanger onto trunnion tube. Do not tighten trunnion hanger capscrews and nuts at this time.

(2) Slide trunnion washer and rubber bushing onto trunnion tube.

(3) Install the upper and lower trunnion hubs on the trunnion tube.

(4) Using lifting device, position spring on upper trunnion hub so that center bolt of spring is in recess of trunnion hub.

(5) Put wear plate in position on the spring. The nut on the center bolt of the spring fits into hole in the wear plate.

(6) Install two U-bolts over wear plate and through holes in upper and lower trunnion hubs.

(7) Install four washers and four nuts on U-bolts, and tighten evenly to 200--320 lb.-ft.

(8) Repeat steps (1) through (7) for opposite side.

d. Installation.

(1) Place a jack under trunnion tube close to inside of each trunnion hanger, and slowly raise suspension into position under trunnion support brackets.

(2) Aline holes in the trunnion hanger with holes in the mounting bracket.

(3) Install four bolts, four washers, and four nuts. As the nuts are tightened, jack up the suspension to seat the trunnion hanger. Tighten nuts evenly to 90 lb.-ft.

(4) Tighten two trunnion hanger capscrews and nuts.

- (5) Repeat steps (2) through (4) for opposite side.
- (6) Install both axles (para 5-15).
- (7) Install wheels on both axles (para 4-49).
- (8) Remove supports and jacks, and lower rear end of semitrailer to ground.

**5-14. Axle M967, M969, and M970 except M970 SN TC-0843, TC-0844, and TC-103 thru T-178).**

*a. Removal (Fig. 5-3).*

- (1) Position semitrailer on hard, level surface with front resting on landing gear.

**WARNING**

**Release air pressure from both air reservoirs before doing any work on brake lines or other pressurized air lines.**

- (2) Release air from both air reservoirs by opening drain cocks on bottom of reservoirs (fig. 4-79).
- (3) Loosen wheel nuts while wheels are on ground.
- (4) Position jacks approximately 18-inches to the inside of lower torque rod brackets on axle. Jack up axle to be removed until wheels are 1-inch off the ground.
- (5) Remove wheels (para 4-49).
- (6) Raise rear of semitrailer with an overhead crane or A-frame support until weight of springs has been removed from axle. Block frame securely (fig. 5-3).
- (7) Tag and disconnect air lines from brake chambers on axle being removed.
- (8) Disconnect upper and lower torque rods from the axle being removed (para 5-11).
- (9) Revolve axle away from the springs until free. Use a dolly jack and remove axle.

*b. Installation (Fig. 5-3).*

- (1) Move axle into position under semitrailer. Upper torque rod bracket on axle should be toward right (curbside) of semitrailer. Position jacks approximately 18-inches to the inside of lower torque rod brackets on axle. Raise and revolve the axle into position on ends of suspension springs.

- (2) Connect upper and lower torque rods (pars 5-11).
- (3) Connect air lines to brake chambers as tagged.
- (4) Install wheels (para 4-49).
- (5) Remove supports and jacks.
- (6) Tighten wheel nuts to proper torque and in proper sequence (pars 4-49).

**5-15. Axle M967A1, M969A1, and M970A1 including M970 SN TC-0843, TC-0844, and TC-103 thru TC-78).**

*a. Removal (Fig. 5-5).*

- (1) Position semitrailer on hard, level surface with front resting on landing gear.

**WARNING**

**Release air pressure from both air reservoirs before doing any work on brake lines or other pressurized air lines.**

- (2) Release air from both air reservoirs by opening drain cocks on bottom of reservoirs (fig. 4-79).
- (3) Loosen wheel nuts while wheels are on ground.
- (4) Position jacks just inboard of the spring end up on axle. Jack up axle to be removed until wheels clear the ground.
- (5) Remove wheels (para 4-49).
- (6) Raise rear of semitrailer with an overhead crane or A-frame support until weight of springs has been removed from axle. Block frame securely (fig. 5-5).
- (7) Remove brake air chambers (para 4-38).
- (8) Remove four nuts, four washers, and four bolts which fasten the spring end cap to spring seat on axle.
- (9) Remove four nuts, four washers, and two U-bolts which fasten the spring seat on axle to the spring end cap.
- (10) Remove leaf spring seats.
- (11) Remove cushioning pads.
- (12) Remove adjustment plates.

- (13) Repeat steps (8) through (12) for other side.
- (14) Slowly lower axle.

b. *Installation (Fig. 5-5).*

(1) Move axle into position under semitrailer. Raise and revolve axle into position on ends of suspension springs.

(2) At each end of axle, loosely install spring seats, adjustment plates, cushioning pads, and spring end caps with two U-bolts, four washers, and four nuts.

(3) At each end of axle, loosely install spring end cap to spring seat on axle with four bolts, four washers, and four nuts.

- (4) Tighten all nuts evenly to 200-320 lb.-ft.
- (5) Install brake air chambers (para 4-38).
- (6) Install wheels (para 4-49).
- (7) Remove supports and jacks.

(8) Tighten wheel nuts to proper torque and in proper sequence (pars 4-49).

**5-16. Bogie Assembly (M967, M969, and M970 except M970 SN TC-0843, TC-0844, and TC-103 thru TC-178).**

a. *Removal.*

(1) Position semitrailer on hard, level surface with front resting on landing gear. Raise rear of semitrailer with an overhead crane or A-frame support until all wheels are approximately 1-inch off the ground. Block the frame securely (fig. 5-3).

**WARNING**

**Release air pressure from both air reservoirs before doing any work on brake lines or other pressurized air lines.**

(2) Release air from both air reservoirs by opening drain cocks on bottom of reservoirs (fig. 4-79). Tag and disconnect eight hoses from brake air chambers on both axles. Manually release the fail-safe springs (para 2-4).

(3) Remove two upper torque rods (para 5-11).

(4) Position jacks under mounting brackets of trunnion cross tube (one jack under each bracket) to support weight of trunnion cross tube. Remove four nuts, washers, and bolts which fasten each mounting bracket to support bracket (fig. 5-3).

(5) Remove jacks from under trunnion cross tube. Raise semitrailer another 16-inches, or until there is enough clearance to roll the bogie assembly and wheels out from under rear of semitrailer (fig. 5-6).

(6) Lower semitrailer onto supports or cribbing after bogie assembly is removed (fig 5-3).

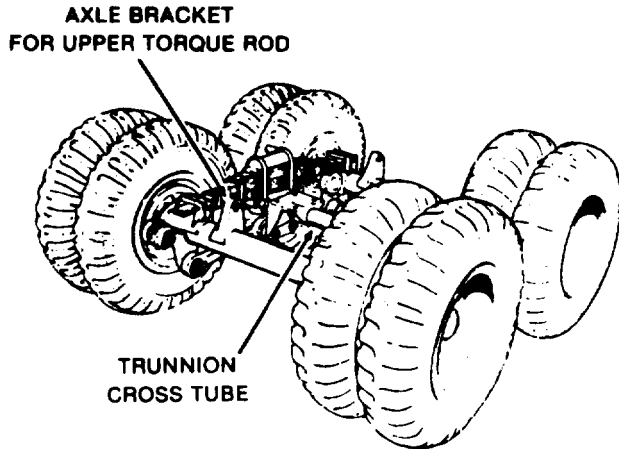

TA100053

*Figure 5-6. Bogie Assembly Removed from Semi-trailer (M967, M969, and M970 except M970 SN TC-0843, TC-0844, and TC-103 thru TC-178).*

b. *Installation.*

**NOTE**

**The upper torque rods on the front and rear axles will be toward the right aide (curbside) of the semitrailer if the bogie assembly is installed correctly.**

(1) Raise rear of semitrailer to allow bogie assembly to roll under frame from rear. With front of bogie assembly toward front of semitrailer, roll bogie assembly into position under support brackets for trunnion cross tube.

(2) Lower the semitrailer to within 1-inch of the trunnion cross tube bracket. Ensure that the holes of the support brackets are in line with holes in trunnion cross tube bracket.

(3) Install eight bolts, washers, and nuts. As you tighten the nuts, jack up the trunnion cross tube brackets to seat the support brackets. Tighten nuts to 450-650 lb.-ft. Remove jacks.

(4) Install upper torque rods (para 5-11).

(5) Connect hoses to brake chambers as tagged. Manually release fail-safe springs (pars 2-4).

(6) Remove supports and jacks.

### 5-17. **Bogie Assembly M967A1, M969A1, and M970A1 including M970 SN TC-0843, TC-0844, and TC-103 thru TC-178).**

#### a. *Removal.*

(1) Position semitrailer on hard, level surface with front resting on landing gear.

(2) Jack up rear of semitrailer and support under frame securely until weight of semitrailer is removed from springs and axles (fig. 5-5).

(3) Release air from both air reservoirs by opening drain cocks on bottom of reservoirs (fig. 4-79).

(4) Tag and disconnect eight hoses from brake air chambers on both axles. Manually release the fail-safe springs (para 2-4).

(5) Position a jack under the trunnion tube close to the inside of each trunnion hanger to support weight of trunnion tube.

(6) Remove four nuts, four washers, and four bolts which fasten the trunnion hanger to the mounting bracket. Repeat for opposite side.

(7) Remove jacks from under trunnion tube. Raise semitrailer until there is enough clearance to roll the bogie assembly and wheels out from under rear of semitrailer (fig. 5-5).

(8) Lower semitrailer onto supports or cribbing after bogie assembly is removed (fig 5-5).

#### b. *Installation.*

(1) Raise rear of semitrailer to allow bogie assembly to roll under frame from rear. With front of bogie assembly toward front of semitrailer, roll bogie assembly into position under mounting brackets for the trunnion hangers.

(2) Position a jack under trunnion tube as close as possible to the inside of each trunnion hanger.

(3) Lower the semitrailer to within 1-inch of the trunnion hangers.

(4) Aline holes in mounting bracket with holes in trunnion hanger.

(5) Install four capscrews, four washers, and four nuts. As the nuts are tightened, jack up trunnion tube to seat the trunnion hanger. Tighten nuts to 90 lb.-ft.

(6) Tighten two trunnion capscrews and nuts.

(7) Repeat steps (4) through (6) for opposite side.

(8) Connect eight hoses to brake air chambers on both axles as tagged. Manually release the fail-safe springs (pars 2-4).

(9) Remove jacks and supports, and lower semitrailer to ground.

### 5-18. **Engine and Pump Assembly**

#### NOTE

- **The engine and pump assembly is removed and installed as a unit power plant. Removal of the complete module is necessary to remove the engine.**
- **The pump can be removed without removing the complete module.**

#### a. *Removal (Fig 5-7).*

(1) Disconnect negative, then positive battery cables from batteries (1).

(2) Remove self-tapping screws from muffler shroud (2). Remove muffler shroud.

(3) Remove the alternator adjusting bracket (3) from the alternator to get clearance for removal of throttle cable.

(4) Loosen wing screws and remove panel door (5) on air housing. Remove throttle cable (4) (para 4-75).

(5) Remove ¼-inch oil pressure tube (7) for oil pressure gage from oil adapter. Remove ¼-inch fuel pressure tube (6) from primary filter. Cut the tie straps, then pull oil pressure tube and fuel pressure tube from the engine compartment.

(6) Disconnect control panel wiring harness plug (8) from junction box on engine frame by turning counterclockwise with hook-type spanner wrench.

#### CAUTION

**Ensure that fuse has been removed first to prevent damage.**

(7) Disconnect electrical lead for hose reels (M969, M969A1, M970, and M970A1) above and to right of fuse (para 4-27). Follow control panel wiring harness disconnected above, and remove two nuts and capscrews securing conduit mounting plate to middle of engine frame behind engine.

(8) Remove split couplings, and disconnect pump inlet and outlet lines from the centrifugal pump (10).

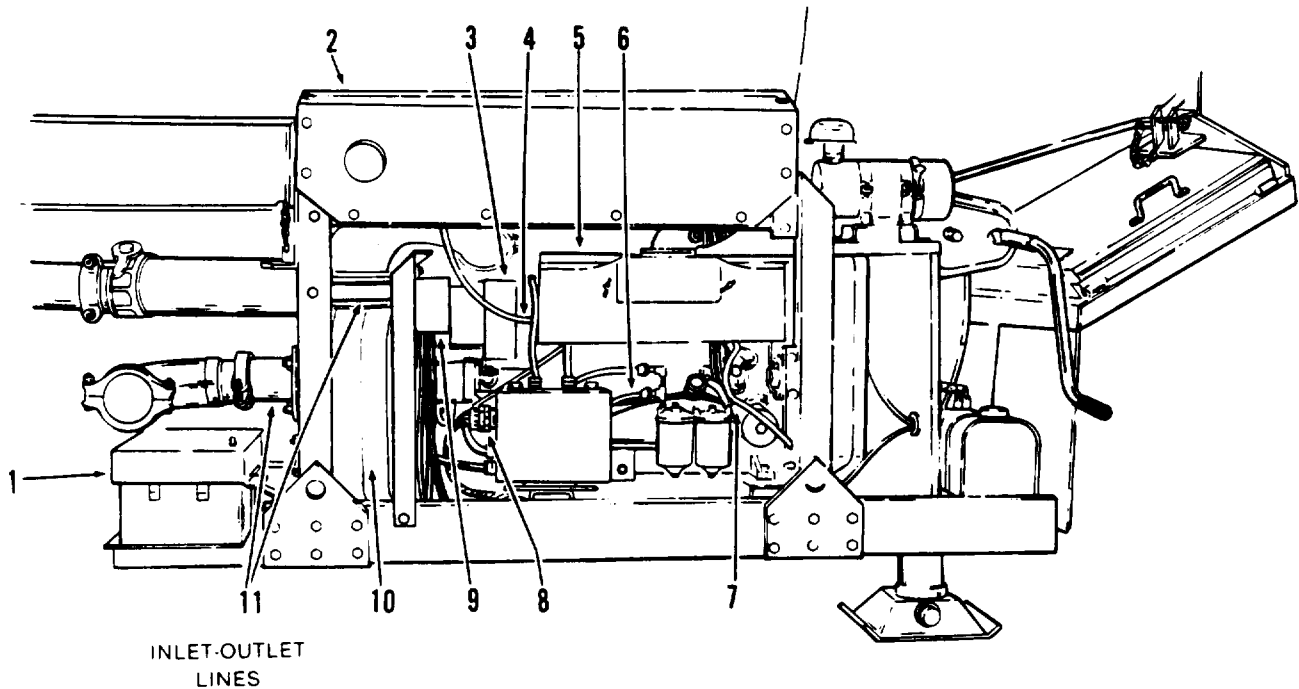

- |                                 |                                      |
|---------------------------------|--------------------------------------|
| 1. Batteries                    | 7. Oil pressure tube                 |
| 2. Muffler side shroud          | 8. Control panel wiring harness plug |
| 3. Alternator adjusting bracket | 9. Buss bar                          |
| 4. Throttle cable               | 10. Centrifugal pump                 |
| 5. Panel door                   | 11. Inlet and outlet lines           |
| 6. Fuel pressure tube           |                                      |

TA100054

Figure 5-7. Engine and Pump Assembly Installed on Semitrailer.

(9) Remove four locknuts and capscrews (fig. 5-8) which secure rear cross brace to engine frame. Remove six locknuts and capscrews which fasten the support bracket for the engine frame to the tank frame near front of semitrailer. The support bracket should remain on the engine frame.

(10) Position lift truck forks under engine frame to take up the weight of the engine module. Remove locknuts and capscrews which fasten engine module to tank. Slowly remove module by backing the lift truck straight away from the semitrailer.

*b. Installation.*

(1) Move pump and engine module into position with forklift truck. Attach engine frame to semitrailer with capscrews and locknuts.

(2) Attach front support bracket (fig. 5-8) to semitrailer frame with six capscrews and locknuts. Attach rear cross brace to engine frame with four capscrews and locknuts. Tighten all nuts. Remove forklift truck.

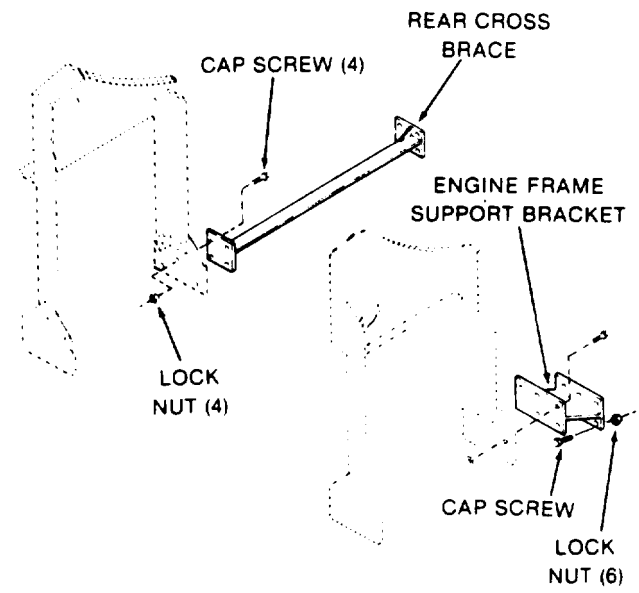

TA100055

Figure 5-8. Engine Frame Mounting Brackets.

(3) Install split couplings to connect pump inlet and outlet lines to tank piping (para 4-85).

(4) Attach conduit mounting plate to middle of engine frame with two screws and locknuts (para 4-25). Connect wiring harness plug (8, fig. 5-7) to junction box. Connect electrical lead for hose reels (M969, M969A1, M970, and M970A1) to buss bar, and install cover.

(5) Install ¼-inch oil pressure tube (7, fig. 5-7) to oil adapter. Install ¼-inch fuel pressure tube (6) to primary falter.

(6) Install throttle cable (para 4-75). Install panel door (5) on air housing. Install alternator adjusting bracket (3) to alternator.

(7) Install muffler shroud (2) over muffler and secure with self-tapping screws.

(8) Connect positive, then negative battery cables to batteries.

### 5-19. Centrifugal Pump

#### a. Removal (Fig. 5-10).

(1) Remove batteries (para 4-23).

(2) Drain piping. Drain filter/separator (M969, M969A1, M970, M970A1). Make sure tank is empty of fuel.

(3) Remove drain plug on bottom of pump and drain fuel from pump.

(4) Remove pump inlet and outlet lines (para 4-91).

(5) Remove screws which fasten two halves of rear firewall (fig. 5-9) to engine frame. Move the half-sections aside to allow for removal of the pump. Do not remove the fuel pumps or buss bar assembly from firewall sections.

(6) Remove alternator (para 4-78).

#### NOTE

**It will be necessary to turn engine crankshaft clockwise with a socket wrench inserted through grille on flywheel housing to reach both capscrews on pump coupling.**

(7) Remove two capscrews and nuts from engine half of pump coupling (fig. 5-10). The engine half of pump coupling will remain on engine. The pump half of the coupling will be removed with the pump.

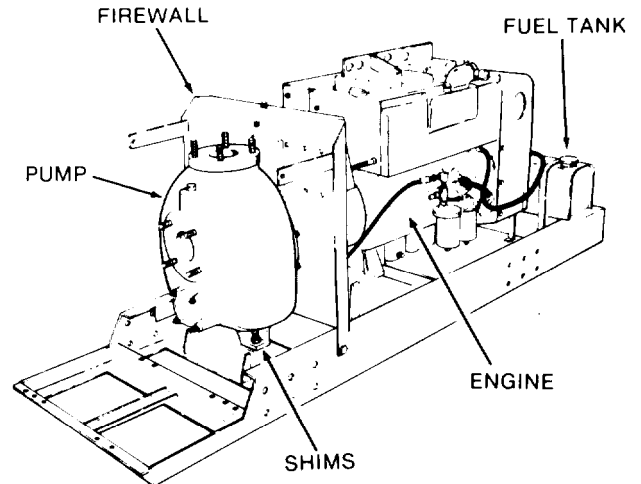

TA100056

**Figure 5-9. Engine and Pump Assembly Removed From Semitrailer**

(8) Remove two screws and nuts from base of pump. Mark the location of shims used in pump mounting.

(9) Remove four capscrews and lockwashers which fasten pump intermediate housing to engine.

(10) Pull pump and intermediate housing straight away from engine and remove them through rear of frame.

#### b. Installation (Fig. 5-10).

(1) Position pump and intermediate housing on engine, alining pump half of coupling with engine half of pump drive coupling. Install four capscrews and lockwashers to fasten intermediate housing to engine. Install two capscrews and nuts to secure two halves of pump coupling (fig. 5-10).

#### NOTE

**If installing same pump, use same shims in same positions.**

(2) Position shims (fig. 5-10) under pump as required to aline pump mounting with engine mounting to within .03-inch. Install two screws and nuts, and tighten to 142-158 lb.-ft.

(3) Install pump inlet and outlet lines (para 4-90). Use new gaskets on pump mounting flanges.

(4) Position half-sections of rear firewall (12 and 14, fig. 5-1 1), and fasten together and to engine frame.

(5) Install alternator (para 4-78).

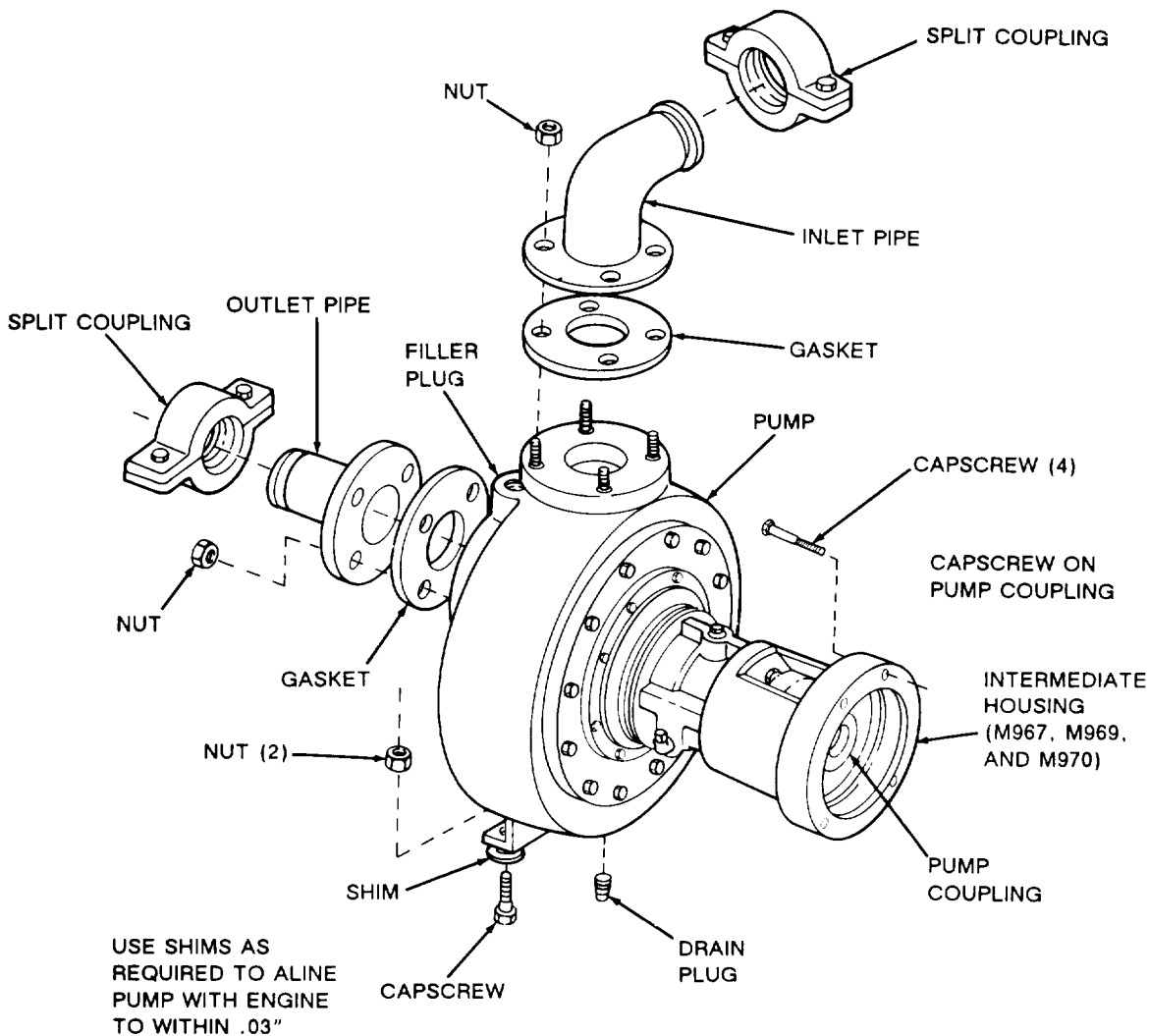

**Figure 5-10. Pump Installation, 4-Inch (Also Typical of 3-Inch Pump).**

TA502300

(6) Install batteries and connect battery cables (para 4-23).

**NOTE**

**The pump is self-priming. Filling the pump is necessary only when the pump has been drained.**

(7) Ensure that drain plug is installed at bottom of pump. Remove filler plug near top of pump and fill pump with fuel that is to be pumped. Install filler plug.

**5-20. Engine (Fig. 5-1 1)**

*a. Removal.*

(1) Remove engine and pump as a unit from the semitrailer (para 5-18).

(2) Remove pump assembly from engine (para 5-19).

(3) Remove ten nuts (29, fig. 5-11), twenty washers (28), ten cap screws (27), and top panel (26).

(4) Tag and disconnect wiring harness and electrical leads from engine (para 4-16).

(5) Remove fuel lines from fuel tank and engine (para 4-73).

(6) Remove air cleaner hose from engine intake manifold (para 4-74). The air cleaner and mounting bracket can be removed with the engine fan shroud.

(7) Remove muffler and exhaust pipe (para 4-77).



(8) Remove two capscrews (13) and nuts (5) that fasten rear firewall sections (14 and 12) to rear panel (6).

(9) Remove capscrews (9 and 8) and nuts (10) that fasten panels (6 and 7) to base frame (11).

(10) Remove two capscrews (25), lockwashers (24), and nuts (23) from bottom of fan shroud (22).

(11) Using a hoist, remove panels (6 and 7), muffler stand (1), and fan shroud (22) from base frame as an assembly.

(12) Remove remaining capscrews (13) and nuts (5), and remove rear firewall sections (14 and 12).

(13) The base frame can be used as a holding fixture for the engine. If engine is to be removed from base frame, remove four mounting screws and nuts.

*b. Installation.*

(1) If engine was removed from base frame, fasten engine base to frame with four mounting screws and nuts.

(2) Install rear firewall sections (14 and 12), and fasten to base frame with screws (13) and nuts (5).

(3) Position panels (6 and 7), muffler stand (1), and fan shroud (22) as an assembly over engine. Position support bracket (18) on front panel (7), and fasten to base frame (11) with six capscrews (9) and nuts (10). Install remaining capscrews (9 and 8) and nuts (10) to fasten panels to base frame. Do not install the four capscrews (9) and nuts (10) for the rear cross brace until the engine and pump module is installed on the semitrailer (para 5-18).

- 1. Muffler stand
- 2. Capscrew (5)
- 3. Washer (5)
- 4. Nut (5)
- 5. Nut (8)
- 6. Panel, rear
- 7. Panel, front
- 8. Capscrew (8)
- 9. Capscrew (24)
- 10. Nut (32)
- 11. Frame
- 12. Firewall, rear section half
- 13. Capscrew (8)
- 14. Firewall, rear section half
- 15. Engine
- 16. Screw (4)
- 17. Nut (4)
- 18. Support bracket
- 19. Capscrew (4)
- 20. Mounting bracket, air cleaner
- 21. Nut (4)
- 22. Fan shroud
- 23. Nut (4)
- 24. Lockwasher (4)
- 25. Capscrew (4)
- 26. Panel, top
- 27. Capscrew (10)
- 28. Washer (20)
- 29. Nut (10)

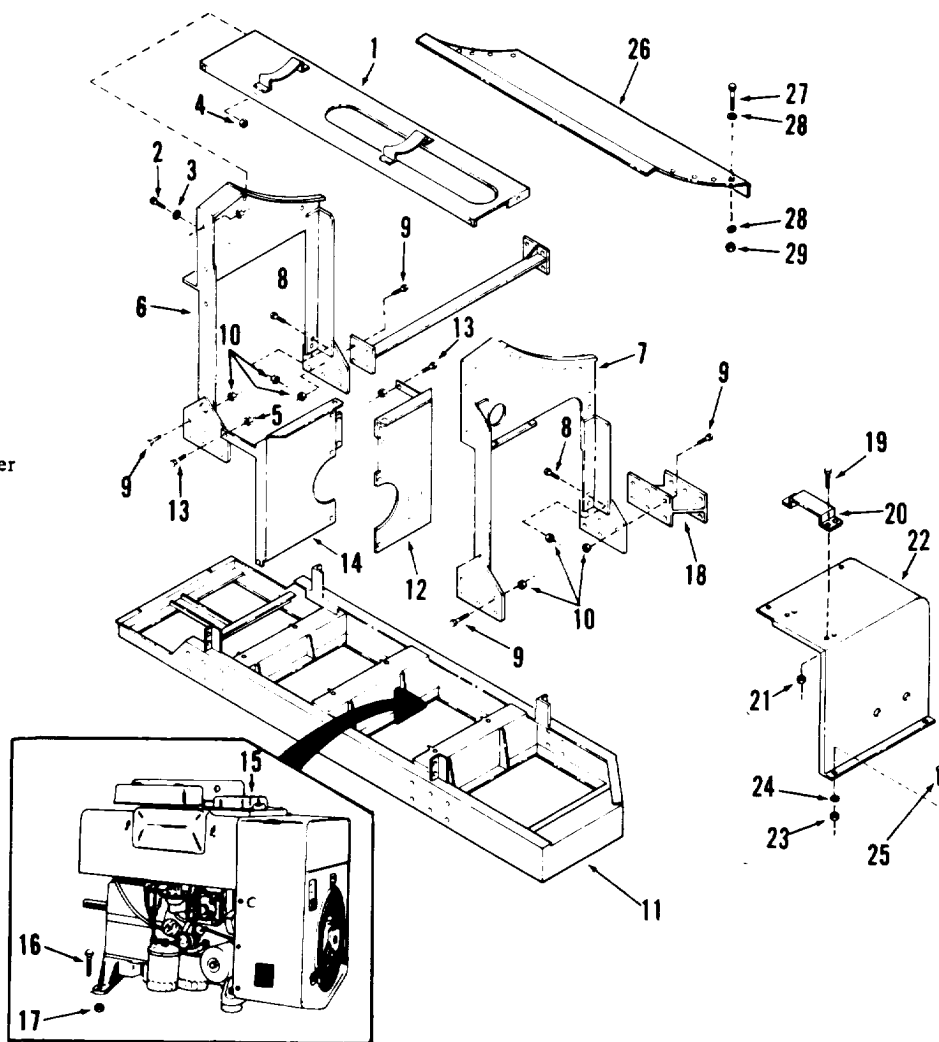

**Figure 5-11. Engine, Base Frame, and Attaching Parts.**

TA100058

(4) Install two capscrews (25), lockwashers (24), and nuts (23) to fasten fan shroud (22) to base frame.

(5) Fasten rear firewall sections (14 and 12) to rear panel (6) with two screws (13) and nuts (5).

(6) Install pump assembly (para 5-19).

(7) Install fuel lines to fuel tank and engine (para 4-73).

(8) Install muffler and exhaust pipe (para 4-77).

(9) Install air cleaner and intake hose (para 4-74).

(10) Install wiring harness and electrical leads (para 4-16).

(11) Ensure that engine crankcase is filled to proper level with correct oil (para 4-71).

(12) Install top panel (26) to panels (6 and 7). Secure with ten capscrews (27), twenty washers (28), and ten nuts (29).

(13) Install engine and pump module on semitrailer (para 5-18).

(14) Install capscrews (9) and nuts (10) for the rear cross brace.

**5-21. Filter/Separator (M969, M969A1, M970, and M970A1) (Fig. 5-12)**

*a. Removal.*

(1) Close valve M on curbside of semitrailer.

(2) Open drain valve Non sump to remove fuel and sediment from filter/separator. Also remove drain plugs on bottom of filter/separator.

(3) Tag and disconnect four lines from filter separator (fig. 5-12).

(4) Remove split couplings from inlet and outlet lines at filter/separator.

(5) Position either lift truck forks or dolly jack under filter/separator to take up weight. Use care not to damage sump components. Remove four nuts and washers from mounting straps. Remove mounting straps and webbing. Remove filter/separator.

*b. Installation.*

(1) Position filter/separator at center of two mounting brackets with drain valve at bottom and service port opening toward outboard side.

(2) Position webbing on mounting straps. Install mounting straps with washers and nuts. Tighten nuts to 142-158 lb.-ft.

(3) Connect four lines for filter/separator as tagged. Two lines for filter/separator gage are connected to elbows at front and rear of filter/separator. Fuel line is connected to elbow at top of filter/separator. Pilot line is connected to control valve on sump.

(4) Install split couplings to connect filter/separator inlet and outlet to tank piping (para 4-85). Tighten two bolts on split couplings to 95-105 lb.-ft.

(5) Close drain valve N and open valve M.

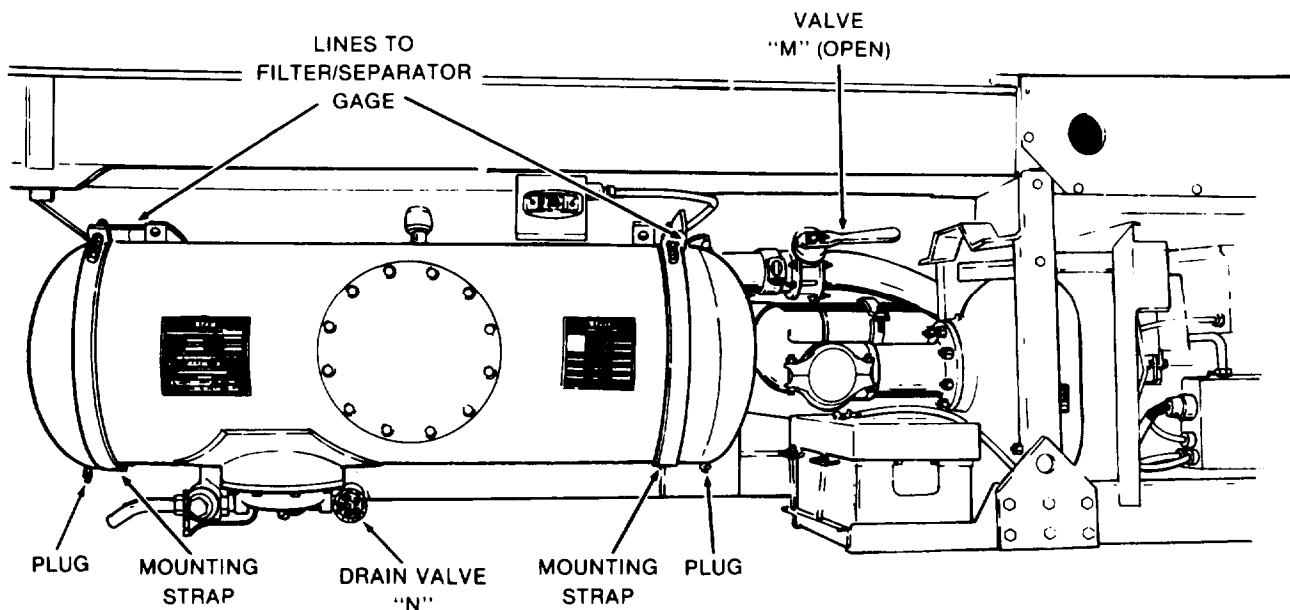

TA100059

**Figure 5-12. Filter/Separator Installation (M969, M969A1, M970, and M970A1).**

**5-22. Hose Reel Cabinet (M969, M969A1, M970, and M970A1)**

**NOTE**

- **The hose reel cabinet must be removed to remove the hose reels.**
- **Tag all lines as they are disconnected for ease of installation.**

*a. Removal.*

(1) Position semitrailer on level surface with front resting on landing gear.

(2) Open valves and drain piping in cabinet area.

(3) Disconnect the negative cables from batteries.

(4) Disconnect the lead inside the electrical junction box on the rear of the cabinet (para 4-27).

(5) Disconnect the conduit at the electrical junction box on the rear of the cabinet (para 4-27).

(6) On the M970 and M970A1 only, perform the following steps:

(a) Disconnect the line that runs to the accumulator (fig. 4-151). This can be done at a fitting at the rear of the cabinet. Pull line into the cabinet.

(b) Disconnect the control cable from the trip bar on the top left side of the cabinet (fig. 5-13).

(c) Remove the cabinet door and frame by removing the ten capscrews, flatwashers, and self-locking nuts. Two people will then be able to lift the door and frame off.

(d) Disconnect three lines on the parking brake control valve (para 4-47).

(e) Disconnect line to deadman hose reel.

(f) Disconnect line to the flow control valve.

(g) Pull disconnected lines through the hole in the rear of cabinet.

(7) On the M969 and M969A1, disconnect the two meter inlet pipes by removing the split couplings from inside the cabinet. On the M970 and M970A1, disconnect the meter inlet pipe by removing the split coupling from outside the rear of cabinet.

(8) On the M969 and M969A1, remove the cabinet door and frame by removing the ten capscrews, washers, and self-locking nuts. Two people will then be able to lift the door and frame off.

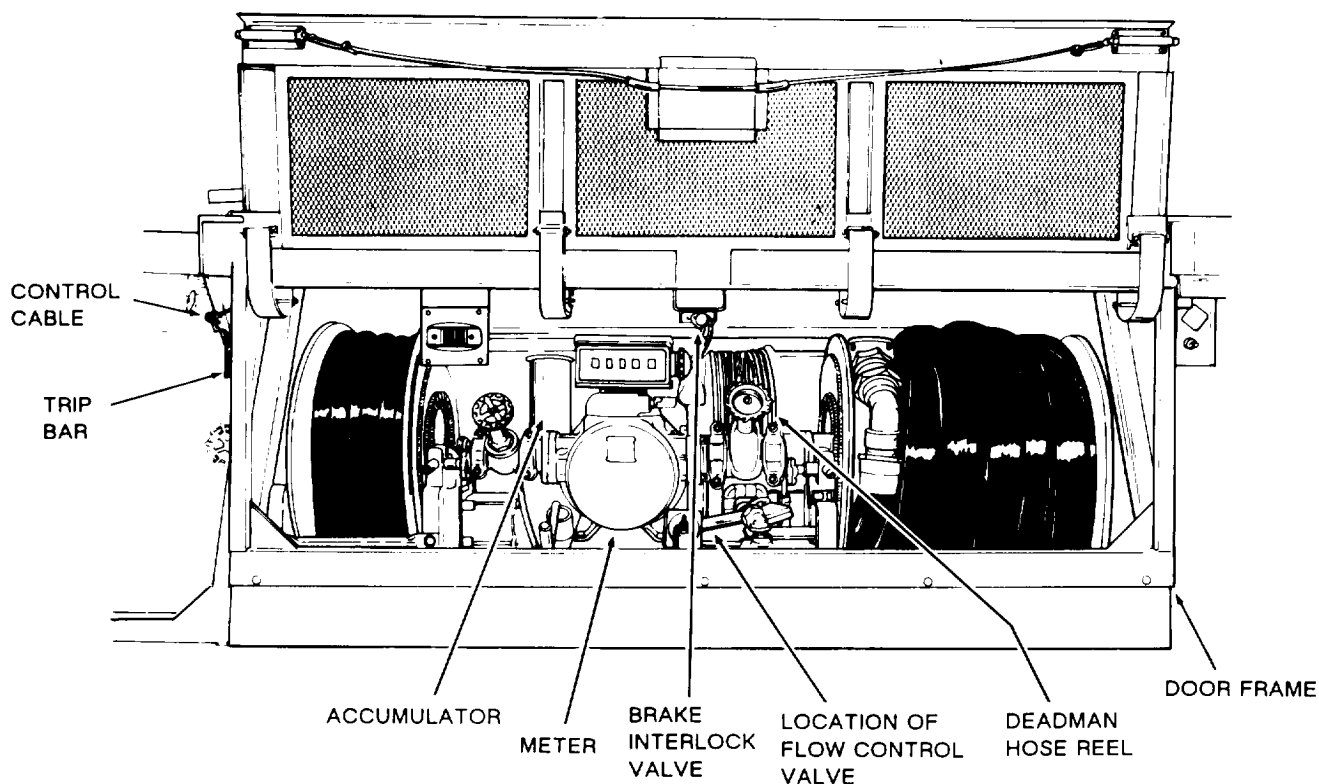

**Figure 5-13, Hose Reel Cabinet (M970 and M970A1).**

TA100060

**WARNING**

**Ensure that forklift is properly positioned under cabinet. The entire weight of the cabinet is now on the forklift. Failure to follow this warning may result in cabinet falling and injuring personnel.**

(9) Position a forklift and lift the cabinet slightly to relieve pressure on the mounting screws and nuts.

(10) Remove eighteen mounting screws and self-locking nuts (7, top left side; 8, top right side; and 3, bottom left side).

**CAUTION**

**Before removing the cabinet, ensure that all disconnections have been made.**

(11) Lower the cabinet slightly and pull the lead from the junction box at the rear of the cabinet.

(12) Remove cabinet.

b. *Installation.*

**WARNING**

**Ensure that forklift is properly positioned under cabinet. The entire weight of the cabinet is now on the forklift. Failure to follow this warning may result in cabinet falling and injuring personnel.**

**NOTE**

**Ensure that all lines are connected as tagged.**

(1) Position a forklift under the hose reel cabinet.

(2) Position hose reel cabinet under semitrailer and fasten with eighteen capscrews and self-locking nuts (7, top left side; 8, top right side; and 3, bottom left side). Remove forklift.

(3) On M969 and M969A1, install split couplings to connect both inlet piping to meter inlet tubes (para 4-85). On M970 and M970A1, install split coupling behind hose reel cabinet to connect inlet piping to meter inlet tube. Tighten split coupling capscrews to 95-105 lb.-ft.

(4) Thread lead to the inside of the junction box on rear of cabinet.

(5) On the M970 and M970A1, do the following (fig. 5-13):

(a) Thread disconnected lines through the hole at the rear of cabinet.

(b) Connect line to the flow control valve.

(c) Connect line to the deadman hose reel.

(d) Connect three lines to the parking brake control valve (para 4-47).

(e) Install cabinet door and frame assembly. Attach frame to hose trough and cabinet hose with ten capscrews, flatwashers, and self-locking nuts.

(f) Connect the control cable to the trip bar on the top, left side of the cabinet.

(g) Connect the line that runs to the accumulator (fig. 4-151).

(6) Connect the conduit to the junction box,

(7) Connect the lead to the inside of the junction box on the rear of the cabinet (para 4-27).

(8) Connect negative battery cables to batteries.

(9) Operate dispensing equipment and check for leaks (table 2-1).

**5-23. Hose Reel Assembly-2½-inch (Fig. 5-14)**

a. *Removal.*

**NOTE**

**The 2½-inch hose reel, hose reel motor, and electrical junction box will be removed as a unit in this procedure.**

(1) Remove hose reel cabinet from semitrailer (para 5-22).

(2) Remove 2½-inch hose from reel by releasing quick disconnect coupling.

(3) Remove cover from motor junction box (fig. 5-14).

(4) Tag and disconnect leads that enter from the top and bottom of the box.

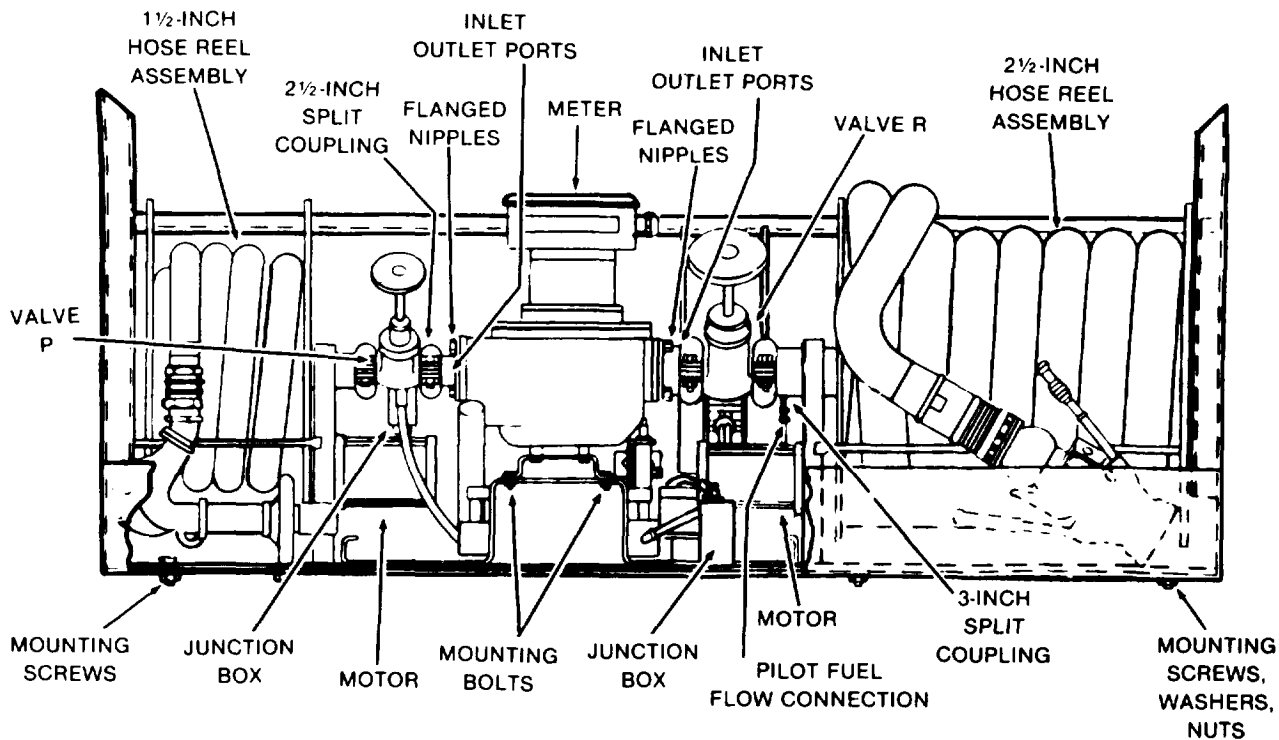

Figure 5-14. Hose Reel Cabinet, (M970 and M970A1) Roadside View.

TA100062

**CAUTION**

**Do not disconnect the motor junction box from the motor. Nipple is specially packed for explosion resistance.**

(5) Disconnect conduit at the top and bottom of the junction box.

(6) Remove valve R.

(7) Remove pilot fuel flow line (fig. 5-14). Have a container ready to catch the flow when disconnection is made.

(8) Remove four mounting screws, nuts, and washers on bottom of hose reel assembly.

(9) Two people can now lift the hose reel, motor, and motor function box from the cabinet.

*b. Installation.*

(1) Have two people lift the hose reel assembly back into cabinet.

(2) Replace four mounting screws, nuts, and washers. Do not tighten mounting screws until valve R is fitted into place.

**NOTE**

**Hose reel will slide slightly from side to side to allow room for valve R.**

(3) Fit valve R and two split couplings in place between hose reel and meter (para 4-85).

(4) When valve R is in place, tighten mounting screws and nuts to 20-35 lb.-ft.

(5) Tighten split coupling to 95-105 lb.-ft.

(6) Connect pilot fuel flow line (fig. 5-14) to hose reel inlet.

(7) Connect leads and conduit to motor junction box as tagged.

(8) Install cover on junction box.

(9) Install hose on hose reel.

(10) Install hose reel cabinet to semitrailer (para 5-22).

**5-24. Hose Reel Assembly- 1¼-inch and 1 ½-inch (Figs. 5-14 and 5-15)**

*a. Removal.*

(1) Remove hose reel cabinet from semitrailer (para 5-22).

(2) Remove hose assembly from hose reel using a pipe wrench or spanner wrench (para 4-89).

(3) Remove cover on motor junction box. Tag and disconnect electrical leads and conduit from motor junction box.

(4) Remove split coupling to disconnect hose reel from meter (M969 and M969A1) or gate valve P (M970 and M970A1).

(5) Remove mounting screws, washers, and nuts. TWO people can then lift the hose reel from the cabinet.

*b. Installation.*

(1) Have two people position hose reel in cabinet. Install mounting screws, washers, and nuts. Tighten nuts to 25-35 lb.-ft.

(2) Install split coupling (para 4-85). Tighten coupling to 57-63 lb.-ft.

(3) Connect electrical leads and conduit to motor junction box as tagged. Install cover on junction box.

(4) Install hose assembly on hose reel (para 4-89).

(5) Install hose reel cabinet to semitrailer (para 5-22).

**5-25. Meter Assembly (M969 and M969A1) (Fig. 5-15)**

*a. Removal.*

(1) Remove split couplings on meter inlet and outlet lines. Slide the coupling gaskets towards the meter to expose the joint in the piping.

(2) From under cabinet, remove three mounting screws. Use a suitable lifting device and remove meter.

(3) Remove flanged connections from meter inlet and outlet after meter is removed from cabinet. Discard gaskets from flanges.

*b. Installation.*

(1) Use new gaskets, and install flanged connections on inlet and outlet ports of meter. Tighten four nuts on each flange to 50-75 lb.-ft. Install gaskets for split couplings.

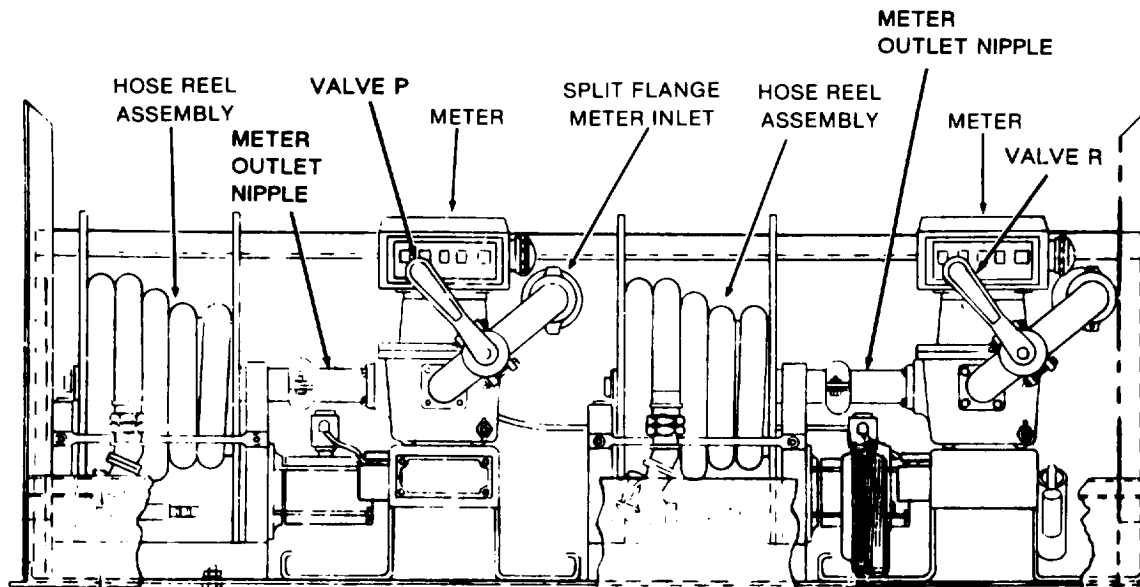

TA502380

*Figure 5-15. Hose Reel Cabinet Assembly, (M969 and M969A1) Roadside View.*

(2) Position meter assembly in cabinet. Ensure that spacers are in position under meter. Install three mounting screws and washers from under cabinet.

(3) Install split couplings (para 4-85). Tighten couplings to 57-63 lb.-ft.

**5-26. Aqua-Glo Probe and Adapter Installation (M969 and M969A1)**

*a. General.*

(1) The Aqua-Glo probe and adapter may be installed on the meter outlet nipple of either meter (fig. 5-15).

(2) The installation provides a port downstream of the filter/separator to draw fuel samples for water (Aqua-Glo) test.

(3) Refer to TM9-237 for information on welding procedures to be followed.

*b. Materials and Parts.*

(1) Probe and adapter assembly, NSN 4930-01-013-7589.

(2) Aluminum rod, alloy, 6061-6063, for fabrication of ferrule.

(3) Aluminum welding rod compatible with aluminum alloy, 6061-6063.

(4) Thread sealing compound, NSN 8030-01-009-2590.

*Installation.*

(1) Observe all applicable warning/safety precautions (inside front cover and safety summary).

(2) Refer to paragraph 4-85 for general information on maintenance of dispensing equipment.

(3) Close meter shut-off valves P or R, and drain fuel from fuel hoses (fig. 5-15).

(4) Scribe location of opening to be drilled in meter outlet nipple approximately 3-inches from the flanged end on a 45° angle (fig. 5-16).

(5) Remove meter outlet nipple (para 5-25) and flush thoroughly with water to eliminate fumes.

(6) Fabricate ferrule from aluminum rod 6061-6063 (fig. 5-17).

(7) Drill a 3/4-inch diameter hole in the meter outlet nipple as described in step (4).

(8) Insert ferrule into meter outlet nipple approximately 1/2-inch. This will allow the assembled probe to extend approximately halfway into the meter outlet nipple (fig. 5-18). Weld ferrule in place.

(9) Install meter outlet nipple (para 5-25).

(10) Use thread sealing compound and install Aqua-Glo probe and adapter. Tighten until the probe angle is in line with direction of flow (fig. 5-18).

(11) Check for fuel leaks. No leaks are permitted.

(12) Paint adapter and reworked areas.

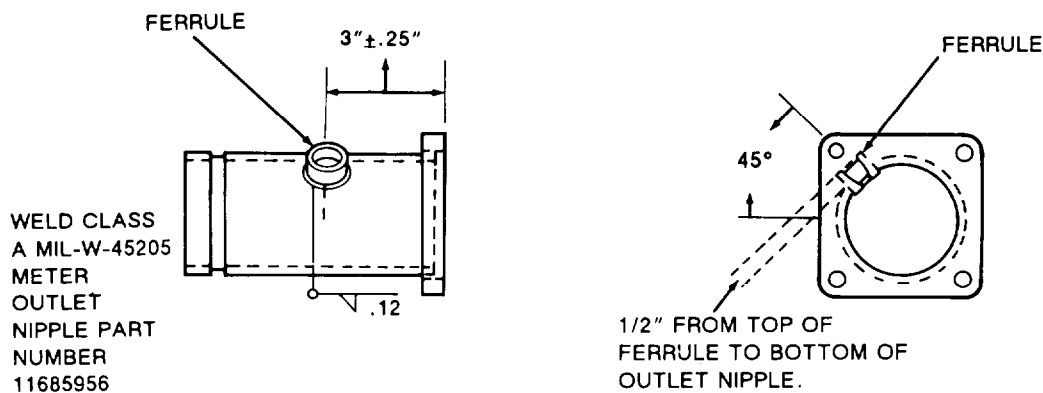
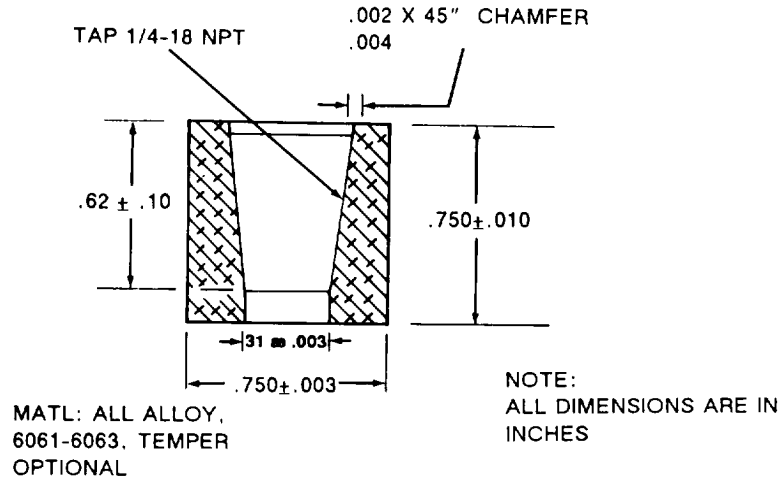

Figure 5-16. Location of Ferrule on Meter Outlet Nipple.

TA502301



TA502302

Figure 5-17, Fabrication Instructions for Ferrule.

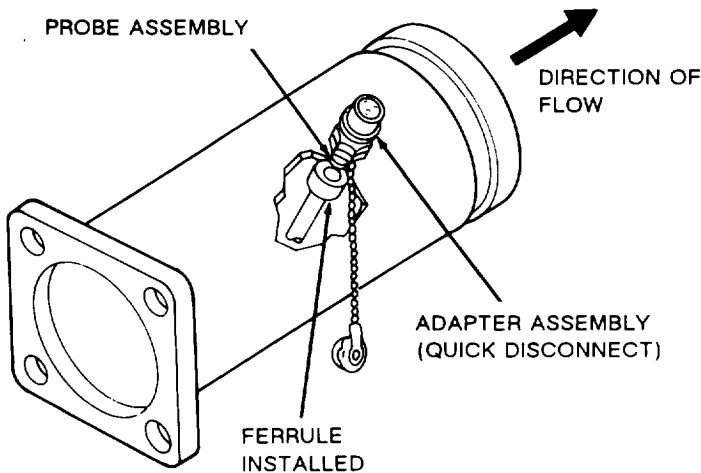

Figure 5-18. Probe Assembly Installed in Meter Outlet Nipple.

**5-27. Meter Assembly (M970 and M970A1)  
(Fig. 5-14)**

*a. Removal.*

(1) Remove split couplings from nipples on both sides of meter. Slide the coupling gaskets onto pipe ends away from the meter. At rear of meter, remove four nuts from studs on meter inlet.

(2) Remove four mounting screws and nuts. Remove meter.

(3) Flanged nipples on meter inlet and outlet ports can be removed after meter is removed from cabinet.

*b. Installation.*

(1) Use new gaskets. Install flanged nipples on outlet ports of meter. Fasten flange to meter with four capscrews and lockwashers. Tighten capscrews to 50-75 lb.-ft.

(2) Put new gasket over studs on meter inlet port. Position meter in cabinet and connect to inlet piping with four self-locking nuts. Tighten nuts to 50-75 lb.-ft. Install four screws, flatwashers, and self-locking nuts to fasten meter to cabinet. Tighten to 67-74 lb.-ft.

(3) Install split couplings (para 4-85). Tighten 2-inch coupling to 57-63 lb.-ft. Tighten 3-inch coupling to 95-105 lb.-ft.

**5-28. Deadman Hose Reel (M970 and M970A1)  
(Fig. 5-19)**

*a. Removal.*

(1) Deactivate deadman system per instructions on plate inside hose reel cabinet.

(2) Remove meter assembly (para 5-27) and valve R (fig. 5-14) for access to deadman hose reel.

(3) Disconnect air lines from ports on both sides of hose reel (para 4-89).



(4) Remove four mounting capscrews, washers, and nuts from base of hose reel. Use a suitable lifting device and remove hose reel from reel stand.

*b. Installation.*

(1) Position hose reel on reel stand. Loosely install four mounting screws, washers, and nuts. Do not tighten until valve R is in place.

(2) Connect air lines to hose reel (para 4-89).

(3) Install valve R (fig 5-14) and meter assembly (para 5-27).

(4) Tighten mounting nuts to 25-35 lb.-ft.

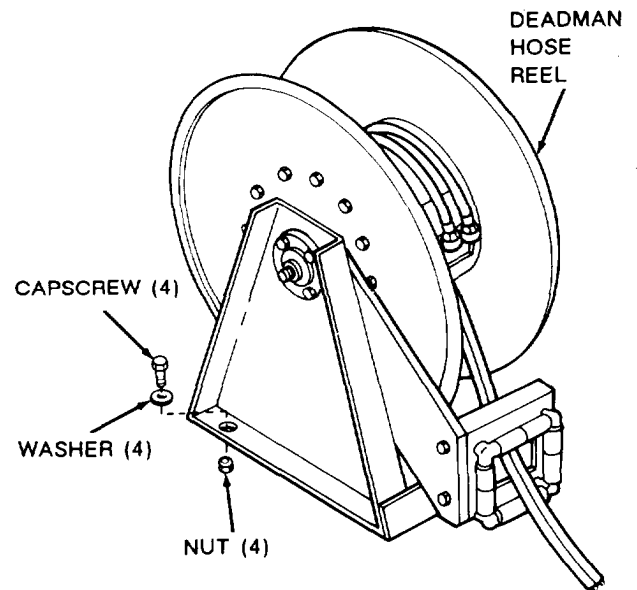

TA502304

**Figure 5-19. Deadman Hose Reel (M970 and M970A1).**



## CHAPTER 6

### REPAIR OF FRAME AND BODY PARTS

---

#### Section I. GENERAL

##### 6-1. scope

This chapter contains instructions for repair and replacement of frame and body parts, including the bogie assembly, which are beyond the scope of the using organization. These repairs, with the exception of repairs to tank body or main frame, are allocated to direct support maintenance. Particular attention must be given to proper purging of the tank before repairs are made (Chapter 4, Section XX).

##### 6-2. Reference

a. *Safety.* Ensure that all safety precautions listed in the Warning Summary are followed while performing maintenance. Pay close attention to all WARNINGS and CAUTIONS.

b. *Procedures.* Procedures for repairs involving welding, surface preparation, cleaning, and painting are included under General Maintenance Procedures (para 5-8).

#### Section II. BODY ASSEMBLY AND SUSPENSION

##### 6-3. Spring Seat Bearings, Wiper and Seals M967, M969 and M970 except M970 SN TC-0843, TC-0844, and TC-103 thru T-178).

###### a. *Disassembly.*

- (1) Remove suspension spring (para 5-12).
- (2) Remove six screws (1) and washers (2) from cap (3). Remove cap and gasket (4).
- (3) Remove jam nut (5), key washer (6), and bearing adjusting nut (8) from end of trunnion cross tube (30).
- (4) Tap the spring seat with a soft hammer to loosen outer bearing cone (9). Remove the bearing cone and spring seat (12). Inner bearing cone (16) and seal assembly (17) will remain in seat. With offset screwdriver, pry seal assembly out of spring seat. Remove inner bearing cone. Do not remove packing retainer (18), felt seals, seal retaining washer, or wiper seal from trunnion cross tube unless damaged.
- (5) If bearings are being replaced, use a bearing puller or a hammer and punch to remove bearing cups (10 and 15) from spring seat. The bearing cone and cup must always be replaced as an assembly.

###### b. *Cleaning and Inspection.*

#### **WARNING**

**Dry cleaning solvent P-D-680 is toxic and flammable. Always wear protective goggles and gloves, and use only in a well-ventilated**

area. Avoid contact with skin, eyes, and clothes, and DO NOT breathe vapors. DO NOT use near open flame or excessive heat. The solvent's flash point is 100°F-138°F (38°C-59°C). If you become dizzy while using cleaning solvent immediately get fresh air and medical help. If solvent contacts eyes, immediately wash your eyes with water and get medical aid.

(1) Clean spring seat, spindle of trunnion cross tube, and bearings with dry cleaning solvent (item 11, Appendix E). Use soft bristle brush to remove old lubrication.

(2) Inspect seat for cracks or damage. Inspect bearing cups and replace if worn, pitted, or scored.

(3) Apply thin coating (not over 1/16-inch thick) of grease (item 17, Appendix E) to inside of seat and to spindle of tube.

(4) Inspect bearing cones for serviceability and lubricate as specified in Section I of Chapter 3.

(5) Inspect oil seal (17) for damage or lack of pliability of sealing material.

###### c. *Assembly (Fig. 6-1).*

(1) Install packing retainer (18), oil seal (19), and wiper (20) onto trunnion cross tube (30) if removed during disassembly.

(2) If bearing cups (10 and 15) were removed, press new cups into spring seat.

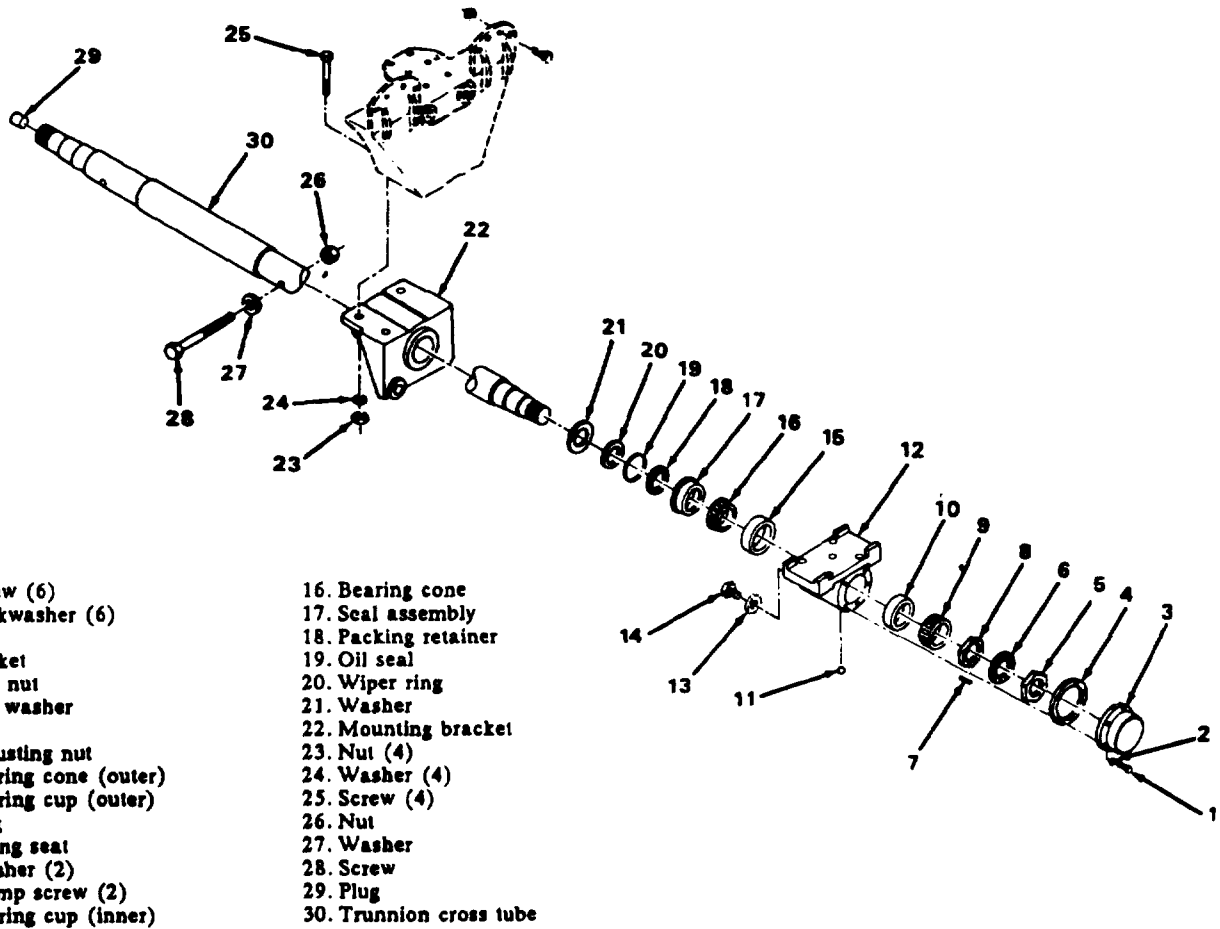

- |                         |                         |
|-------------------------|-------------------------|
| 1. Screw (6)            | 16. Bearing cone        |
| 2. Lockwasher (6)       | 17. Seal assembly       |
| 3. Cap                  | 18. Packing retainer    |
| 4. Gasket               | 19. Oil seal            |
| 5. Jam nut              | 20. Wiper ring          |
| 6. Key washer           | 21. Washer              |
| 7. Pin                  | 22. Mounting bracket    |
| 8. Adjusting nut        | 23. Nut (4)             |
| 9. Bearing cone (outer) | 24. Washer (4)          |
| 10. Bearing cup (outer) | 25. Screw (4)           |
| 11. Plug                | 26. Nut                 |
| 12. Spring seat         | 27. Washer              |
| 13. Washer (2)          | 28. Screw               |
| 14. Clamp screw (2)     | 29. Plug                |
| 15. Bearing cup (inner) | 30. Trunnion cross tube |

**Figure 6-1. Spring Seal and Trunnion Cross Tube Assembly (M967, M969, and M970 except M970 SN TC-0843, TC-0844, and TC-103 thru TC-178).**

TA100084

(3) Position inner bearing cone (16) in spring seat and press seal assembly (17) into position. Use wooden block or discarded seal to press seal squarely into place.

(4) Slide spring seat (12) onto trunnion cross tube (30). Hold seat level with tube. With a rocking motion, push seat carefully into position so seat slides over packing retainer (18) and oil seal (19) slips over wiper (20) without damage. Seat should cover retainer when fully positioned.

(5) Install outer bearing cone (9) and bearing adjusting nut (8). Tighten nut to approximately 25 lb.-ft. to ensure that bearings seat properly. Back off nut until seat can be rotated by hand but without noticeable lateral movement.

(6) Install keywasher (6) on spindle of tube so pin (7) in bearing adjusting nut (8) engages hole in washer. If adjustment is not satisfactory, slide washer outward and turn nut to engage next hole in washer. Install bearing jam nut (5), tighten, and check bearing adjustment again.

(7) Install gasket (4) and cap (3). Secure cover with six screws and washers.

(8) Install suspension spring (para 5-12).

**6-4. Trunnion Cross Tube M967, M969, and M970 except M970 SN TC-0843, TC-0844, and TC-103 thru T-178) (Fig. 6-1).**

*a. Removal.*

(1) Remove spring and spring seat (para 6-3). Do this at both ends of trunnion cross tube.

(2) Remove screw (28) washer (27) and self-locking nut (26) securing trunnion cross tube to mounting bracket (22) on both ends of tube.

(3) Remove torque rods (para 5-11) from mounting bracket (22) on one end of trunnion cross tube. Remove four screws (25), washers (24), and nuts (23). Remove mounting bracket (22).

(4) Remove trunnion cross tube from opposite mounting bracket.

b. Inspection and Repair.

(1) Inspect spindle ends on trunnion cross tube for damaged threads, pitting, scoring, or wear on finished surfaces. Hand chase the threads to remove minor damage or burrs.

(2) Use straightedge and check for bends in the trunnion cross tube. Replace the tube if not serviceable.

(3) Check that plugs (29) are installed in both ends of tube.

c. Installation.

(1) Insert one end of trunnion cross tube into mounting bracket attached to semitrailer. Align hole in

tube with hole in mounting bracket, and install retaining screw (28), washer (27), and self-locking nut (26).

(2) Install mounting bracket (22), and fasten to support bracket with four screws (25) washers (24), and nuts (23). Tighten to 450-650 lb.-ft. Install retaining screw (28), washer (27), and self-locking nut (26).

(3) Install torque rods on mounting bracket (para 5-11).

(4) Install spring seat and spring (para 6-3).

**6-5. Trunnion Cross Tube (M967A1, M969A1, and M970A1 including M970 SN TC-0843, TC-0844, and TC-103 thru TC-178) (Fig. 6-2).**

a. Removal. Refer to paragraph 5-13.

b. Installation. Refer to paragraph 5-13.

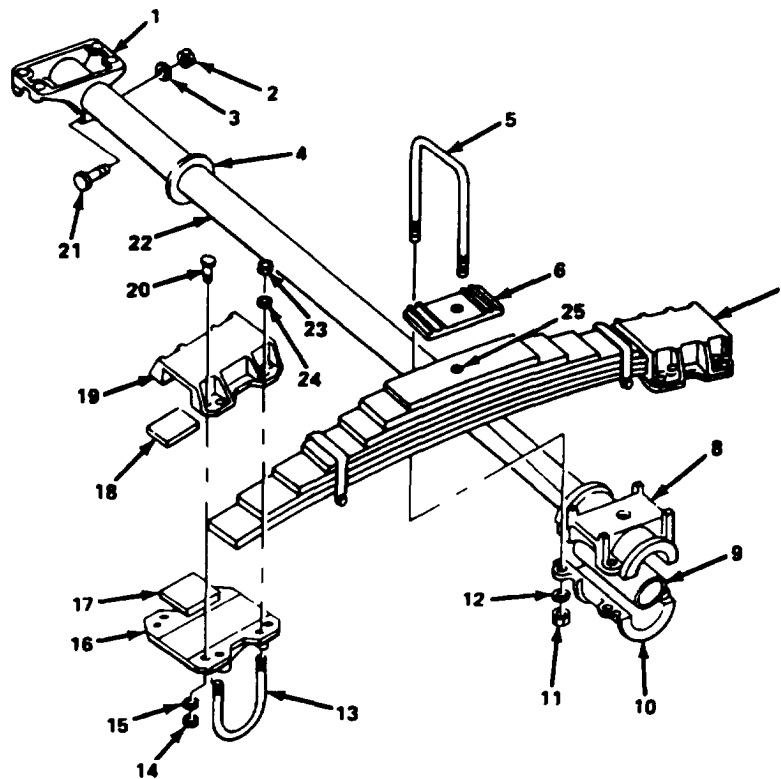

- |                                |                                    |
|--------------------------------|------------------------------------|
| 1. Trunnion spring hanger      | 13. Vehicle suspension U-bolt      |
| 2. Trunnion hanger nut         | 14. End cap nut                    |
| 3. Trunnion hanger flatwasher  | 15. End cap flatwasher             |
| 4. Trunnion hanger flatwasher  | 16. Vehicle suspension spring seat |
| 5. Spring mounting U-bolt      | 17. Spring seat adjustment plate   |
| 6. Spring top wear plate       | 18. End cap pad                    |
| 7. Spring leaf assembly        | 19. Vehicle suspension spring cap  |
| 8. Upper spring trunnion hub   | 20. End capscrew                   |
| 9. Trunnion hub rubber bushing | 21. Trunnion hanger screw          |
| 10. Lower spring trunnion hub  | 22. Trunnion spring tube           |
| 11. U-bolt nut                 | 23. U-bolt nut                     |
| 12. U-bolt flatwasher          | 24. U-bolt flatwasher              |
|                                | 25. Center bolt                    |

TA221138

**Figure 6-2. Spring Seal and Trunnion Cross Tube Assembly (M967A1, M969A1, and M970A1 including M970 SN TC-0843, TC-0844, and TC-103 thru TC-178).**

Section III. BRAKES AND BRAKE SYSTEM COMPONENTS

6-6. Brake Shoes (Fig. 6-3)

a. Disassembly.

**WARNING**

**Due to asbestos hazard, do not grind off rivet heads. Failure to follow this warning may result in injury or death to personnel.**

(1) Punch rivets out from back side of shoe using a hammer and a drift or punch.

(2) Remove linings from brake shoes.

b. Inspection and Repair.

(1) Oil or grease saturated linings are not reusable. Saturated linings indicate leakage in the axle shaft seals.

(2) Grooving or uneven wear in brake linings indicates a need for refacing or replacement of brake drum.

(3) Inspect brake shoe for distortion, cracks or damage. Replace the brake shoe if these conditions are found. Lining and shoe contact surfaces should be clean and smooth.

(4) Use new rivets of the correct body diameter, head size and shape, length, and material.

c. Assembly.

**NOTE**

**Do not use combination linings.**

(1) Make sure lining and shoe contact surfaces are clean.

(2) Clamp lining to brake shoe with C-clamps with rivet holes in both pieces aligned.

(3) Drive the rivets squarely into the holes with a 7/16-inch flat head drift.

(4) Position the C-clamps as close to the rivet holes as possible and make certain the lining is tight against the shoe.

(5) Working from heel to toe of brake shoe, form the rivet heads with the correct tubular rivet set. Follow the order shown in figure 6-3.

(6) Check lining installation with a 0.002-inch feeler gage to ensure that lining and shoe contact. Lining

to shoe clearance is excessive if gage can be inserted between shoe and lining.

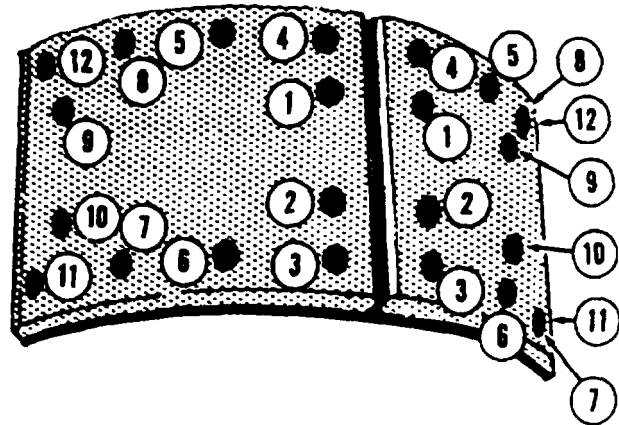

TA100065

Figure 6-3. Brake Lining Riveting Sequence.

6-7. Brake Drums

a. Removal. Refer to paragraph 4-49.

b. Reboring of Brake Drums.

(1) Reboring is not recommended due to reduced strength of refaced drums. If it is necessary to rebores a drum, remove as little metal as necessary to true the friction surface.

(2) If reboring requires removal of more than 1/16-inch of material, replace the drum.

c. Installation. Refer to paragraph 4-49.

**6-8. Brake Air Chamber M867, M969, and M970 except M970 SN TC-0843, TC-0844, and TC-103 thru T-178) (Standard) (Fig. 6-4).**

a. Removal. Refer to paragraph 4-37.

b. Disassembly.

(1) Remove nut (2) and bolt (1) from clamp ring (3). Spread the clamp ring and remove it from the air chamber.

(2) Hold diaphragm (5) to non-pressure housing (8) and remove pressure housing (4).

(3) Carefully remove the diaphragm (5) from the non-pressure housing (8).

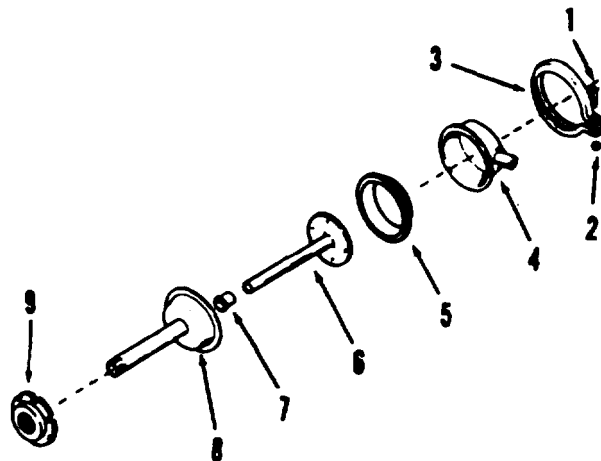

- |                     |                         |
|---------------------|-------------------------|
| 1. Bolt             | 6. Diaphragm plate      |
| 2. Nut              | 7. Wedge guide          |
| 3. Clamp ring       | 8. Non-pressure housing |
| 4. Pressure housing | 9. Collet nut           |
| 5. Diaphragm        |                         |

TA502314

**Figure 6-4. Brake Air Chamber (M967, M969, and M970 except M970 SN TC-0843, TC-0844, and TC-103 thru TC-178) (Standard).**

(4) Remove diaphragm plate (6) and wedge guide (7) from non-pressure housing (8).

(5) Unscrew collet nut (9).

(6) Unscrew non-pressure housing (8).

*c. Cleaning.*

**WARNING**

**Dry cleaning solvent P-D-680 is toxic and flammable. Always wear protective goggles and gloves, and work only in a well-ventilated area. Avoid contact with skin, eyes, and clothes, and DO NOT breathe vapors. DO NOT use near open flame or excessive heat. The solvent's flash point is 100°F-138°F (38°C-59°C). If you become dizzy while using cleaning solvent, immediately get fresh air and medical help. If solvent contacts eyes, immediately wash your eyes with water and get medical aid.**

(1) Clean metal parts with dry cleaning solvent (item 11, Appendix E).

(2) Clean diaphragm with mild soap solution.

*d. Inspection and Repair.*

(1) Inspect wedge guide (7) for damage or wear. If wedge guide is worn more than 25% of its thickness, replace it.

(2) Check tube on non-pressure housing for pits, grooves, or stripped threads. Replace housing if damage is found.

(3) Inspect and replace diaphragm if it is torn or cracked, or if rubber at sealing edge has become set or distorted.

(4) Inspect diaphragm plate for bent push rod or worn or cracked boot. Replace if not serviceable.

*e. Assembly.*

(1) Install wedge guide (7) all the way onto end of push rod of diaphragm plate (6).

(2) Install collet nut (9).

(3) Clean non-pressure housing (8) with cement thinner or similar material in area where boot on diaphragm plate is to be cemented. Apply cement to housing around tube end, then insert the diaphragm plate and push rod assembly into tube. Press boot into position for cementing. Screw non-pressure housing (8) in place.

(4) Install new diaphragm (5) over plate and onto non-pressure housing.

(5) Install pressure housing (4), and secure with clamp ring (3), bolt (1) and nut (2).

*f. Installation.* Refer to paragraph 4-37. Test for leakage after installation by making full brake application and applying soapy water around clamp ring and connections.

**6-9. Brake Air Chamber M967, M969, and M970 except M970 SN TC-0843, TC-0844, and TC-103 thru TC-178) (Fail-Safe Unit) (Fig. 6-5).**

*a. Removal.* Refer to paragraph 4-39.

*b. Disassembly.*

(1) Remove nut (5) and bolt (4) from clamping ring (6). Spread the clamping ring and remove from air chamber.

(2) Carefully separate the fail-safe unit (1) from the non-pressure housing (8). DO NOT disassemble the fail-safe unit. No repairs are authorized for this assembly.

(3) Carefully remove diaphragm (2) from non-pressure housing (8).

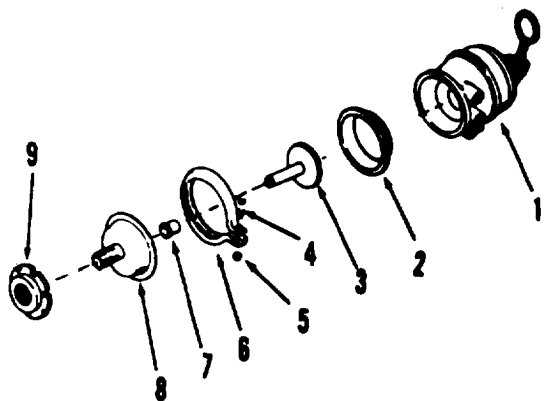

- |                                  |                         |
|----------------------------------|-------------------------|
| 1. Fail-safe unit (spring brake) | 6. Clamp ring           |
| 2. Diaphragm                     | 7. Wedge guide          |
| 3. Diaphragm plate               | 8. Non-pressure housing |
| 4. Bolt                          | 9. Collet nut           |
| 5. Nut                           |                         |

TA502315

**Figure 6-5. Brake Air Chamber (M967, M969, and M970 except M970 SN TC-0843, TC-0844, and TC-103 thru TC-178) (Fail-Safe Unit).**

(4) Remove diaphragm plate (3) and wedge guide (7) from housing.

(5) Remove collet nut (9).

c. *Cleaning.* Refer to paragraph 6-8.

d. *Inspection and Repair.* Refer to paragraph 6-8.

e. *Assembly.*

(1) Perform steps 1 through 4 under paragraph 6-8.

(2) Assemble fail-safe unit (1) to non-pressure housing, and secure with clamp ring (6), bolt (4), and nut (5).

f. *Installation.* Refer to paragraph 4-39. Test for leakage after installation by making full brake application and applying soapy water around clamp ring and connections.

**6-10. Non-adjusting Brake Plunger M967 M969, and M970 except M970 SN TC-843, TC-0844, and TC-103 thru TC-178) (Fig. 6-6).**

a. *Removal.* Refer to paragraph 4-36.

b. *Seal Replacement.*

(1) Pry or cut old seal from plunger. Use care not to damage plunger.

(2) Apply film of grease (item 17, Appendix E) to inside surfaces of new seal assembly.

(3) Put a piece of masking tape over slot for brake shoe web in plunger to protect seal during installation.

(4) Carefully push the double-lip seal assembly onto the plunger. The outer seal lip must be stretched over nose of plunger. Continue to push on seal until inner seal is completely in the second plunger groove and outer seal lip is in the first plunger groove.

(5) Remove masking tape from plunger nose.

c. *Installation.* Refer to paragraph 4-36.

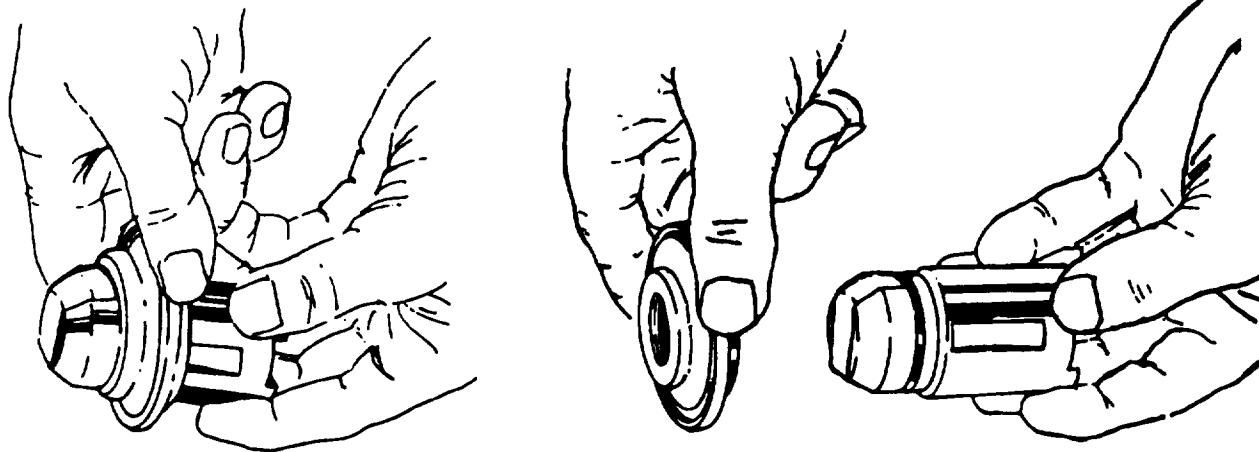

**Figure 6-6. Installing Seal on Non-Adjusting Plunger**

TA100068



## Section IV. FRAME AND BODY PARTS

### 6-11. Frame, Bumpers, and Brackets

#### a. Repair.

(1) Observe all applicable safety precautions listed in the Warning Summary if the possibility of creating sparks exists.

(2) All repairs should be done outside where adequate ventilation and circulation of air will prevent fuel vapor accumulation.

(3) Repair of minor damage such as straightening of bent or dented parts can be accomplished with a pry bar or anvil and heavy hammer.

b. *Replacement.* Frame and body parts that are integral parts of the semitrailer require replacement of the next higher assembly (TM 9-2330-356-24P).

### 6-12. Hose Troughs

a. *Repair.* Repairs are limited to straightening and removal of dents (para 6-11).

b. *Replacement.* The hose troughs are welded to the tank and require replacement of the next higher assembly (TM 9-2330-356-24P).

### 6-13. Piping Control Cabinet

#### a. Removal.

(1) Refer to paragraphs 4-84,4-85, and 4-91, and remove piping and valves inside cabinet.

(2) Remove hose reel cabinet (M969, M969A1, M970, and M970A1) (para 5-22).

(3) Position lift truck forks or dolly jack under piping control cabinet to take up weight. Remove cabinet mounting screws and nuts and remove cabinet.

b. *Repair.* Straighten bent or dented metal. Repair cracks by welding (TM 9-237).

#### c. Installation.

(1) Position cabinet under semitrailer and install mounting screws and nuts.

(2) Install hose reel cabinet (M969, M969A1, M970, and M970A1) (para 5-22).

(3) Install valves and piping (para 4-84,4-85, and 4-91).

### 6-14. Control Panel Assembly

#### a. Removal.

(1) Remove all gages, controls, and instruments from control panel assembly (para 4-24).

(2) Remove panel mounting screws and panels.

b. *Repair.* If control panel cannot be repaired by straightening or welding, replace the control panel.

#### c. Installation.

(1) Position control panel on semitrailer and install mounting screws.

(2) Install decals, gages, instruments, and controls (para 4-24).

### 6-15. Hose Reel Cabinet (M969, M969A1, M970, and M970A1)

a. *Removal.* Refer to paragraph 5-22.

b. *Repair.* Straighten bent or dented metal. Repair cracks by welding (TM 9-237).

c. *Installation.* Refer to paragraph 5-22.

### 6-16. Cabinet Door (M969, M969A1, M970, and M970A1) (Figs. 6-7 and 6-8)

a. *Removal.* Remove cabinet door (para 5-22).

b. *Repair.*

(1) The door hinge is tack welded to the door frame. Break the tack weld with a steel chisel and grind surfaces smooth.

(2) Attach new door to door frame by tack welding in same locations as original welds.

c. *Replacement of Latching Cable (M970 and M70A1).*

(1) Loosen cable clamps at ends of cable, and pull cable from latches and guides.

## WARNING

**DO NOT use an acetylene torch to fuse cable ends unless tank has been cleaned and purged. Failure to follow this warning may result in serious injury or death to personnel.**

(2) Before installing new cable, fuse the cable ends with an acetylene torch to prevent unraveling.

- 1. Screw
- 2. Washer
- 3. Trip bar
- 4. Washer
- 5. Washer
- 6. Nut
- 7. Frame
- 8. Door assembly
- 9. Nut
- 10. Washer
- 11. Latch
- 12. Screw
- 13. Cable—80-inches long
- 14. Cotter pin
- 15. Washer
- 16. Spring
- 17. Pin

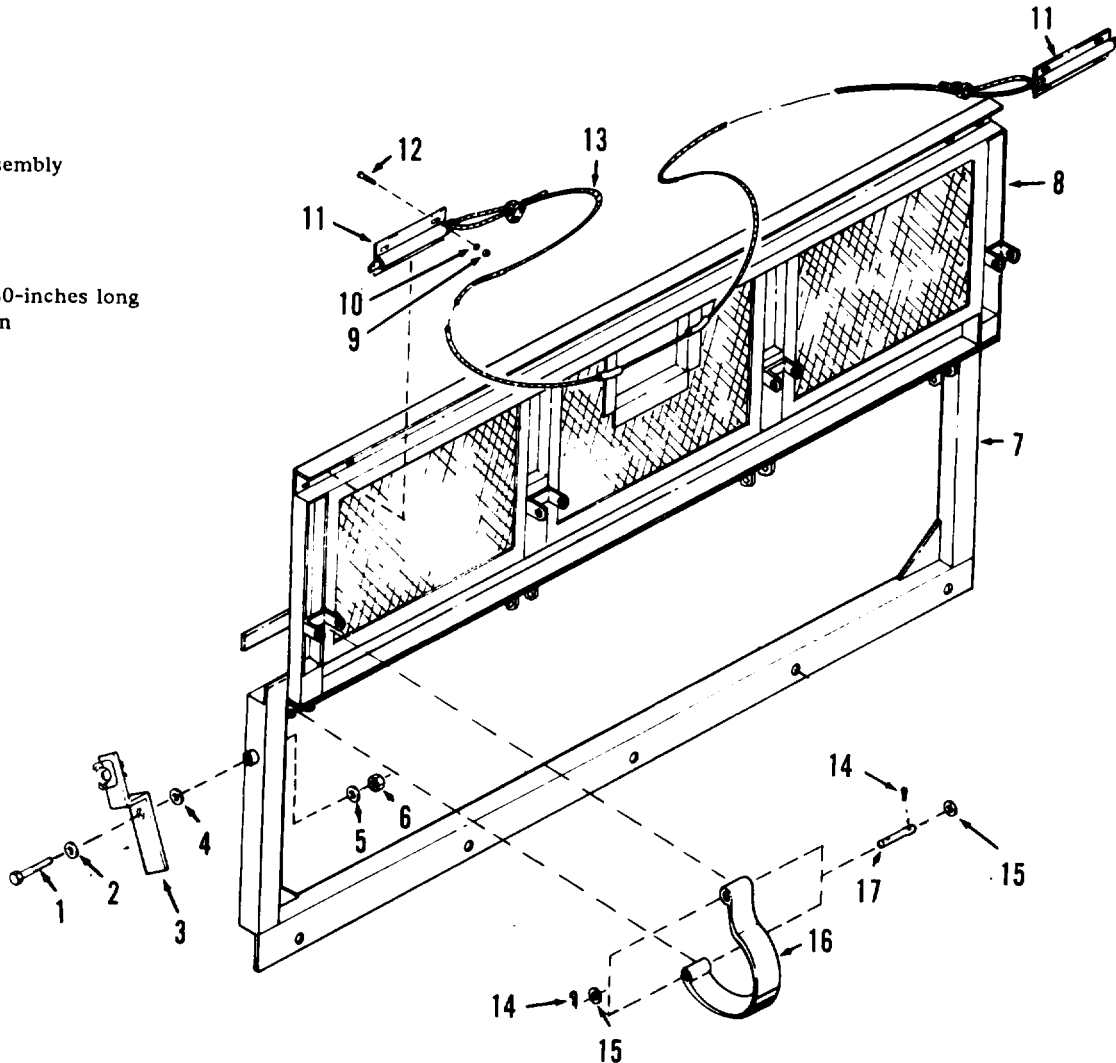

Figure 6-7. Hose Reel Cabinet Door Assembly (M970 and M970A1).

TA100069

(3) Install cable through the guides and latches, and secure with cable clamps. Adjust length of cable to ensure full release and engagement of both latches.

*d. Replacement of Trip Bar (M970 and M970A1).*

(1) Remove nut (6), washer (5), screw (1), washer (2), trip bar (3), and washer (4).

(2) Assemble screw (1), washer (2), trip bar (3), and washer (4).

(3) Push screw (1) through hole in frame (7) and secure with washer (5) and nut (6).

*e. Replacement of Door Spring (M970 and M970A1).*

(1) Remove cotter pin (14) and washer (15) from one end of pin (17). Remove pin (17) from spring (16). Repeat at other end of spring (16).

(2) Aline spring (16) in either door or frame bracket. Push pin (17) through spring (16) and bracket. Secure with washers (15) and cotter pins (14). Repeat at other end of spring (16).

*f. Installation. Install cabinet door (para 5-22).*

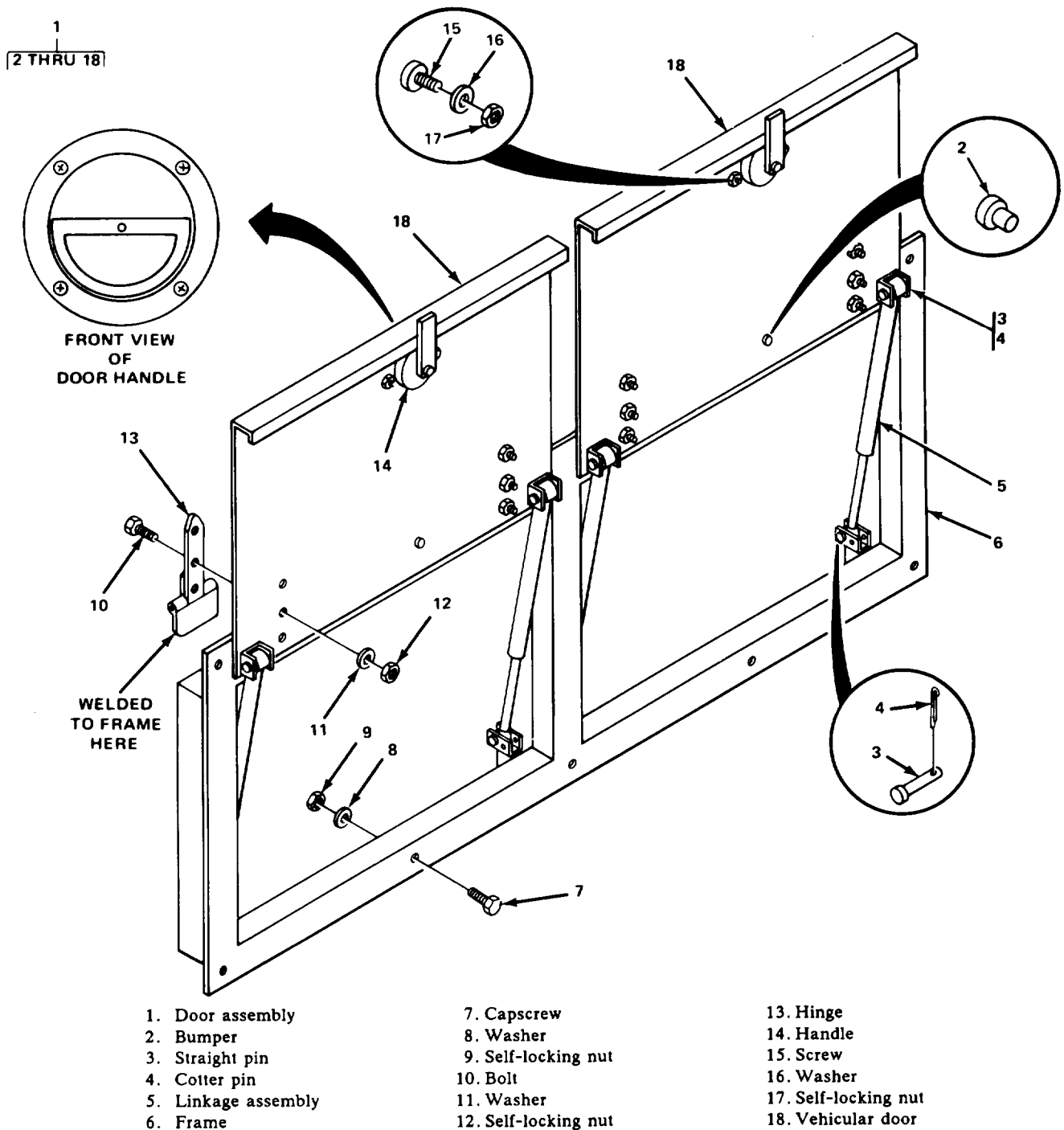

Figure 6-8. Hose Reel Cabinet Door Assembly (M969 and M969A1).

TA502305

**6-17. Landing Gear Leg**

- a. Removal. Remove the leg assembly (para 4-54).
- b. Disassembly (Fig. 6-9).

(1) Pry under cover (1) and remove cover.

(2) Drive out the two roll pins (2 and 3) from pinion shaft (4).

(3) Drive out pinion shaft (4) from upper leg (5), being careful not to damage the two seals (6).

(4) Pinion gear (7) and washer (8) will now be free. Remove these two parts.

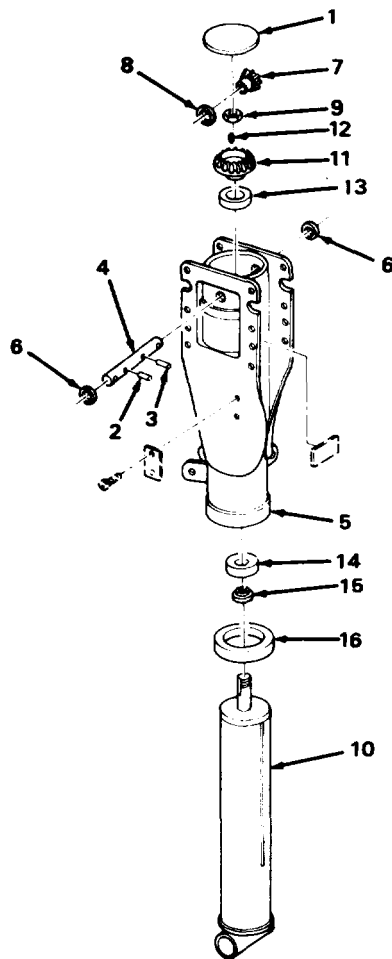

- |                 |                    |
|-----------------|--------------------|
| 1. Cover        | 9. Lock nut        |
| 2. Roll pin     | 10. Lower leg      |
| 3. Roll pin     | 11. Bevel gear     |
| 4. Pinion shaft | 12. Key            |
| 5. Upper leg    | 13. Screw bushing  |
| 6. Seals (2)    | 14. Thrust bearing |
| 7. Pinion gear  | 15. Screw bushing  |
| 8. Washer       | 16. Ring seal      |

TA100070

**Figure 6-9. Landing Gear Leg.**

- (5) Remove locknut (9) from shaft on lower leg (10).
- (6) Using a puller, remove bevel gear (11) and key (12).
- (7) Remove screw bushing (13).
- (8) Secure upper leg (5) and pull lower leg (10) from upper leg.
- (9) Remove thrust bearing (14) and screw bushing (15) from shaft on lower leg.

- (10) Remove ring seal (16) from lower leg.

c. *Cleaning, Inspection, and Repair.*

**WARNING**

**Dry cleaning solvent P-D-680 is toxic and flammable. Always wear protective goggles and gloves, and use only in a well-ventilated area. Avoid contact with skin, eyes, and clothes, and DO NOT breathe vapors. DO NOT use near open flame or excessive heat. The solvent's flash point is 100°F-138°F (38°C-590°C). If you become dizzy while using cleaning solvent, immediately get fresh air and medical help. If solvent contacts eyes, immediately wash your eyes with water and get medical aid.**

- (1) Clean all metal parts in dry cleaning solvent (item 11, Appendix E) and dry thoroughly.

- (2) Inspect the thrust bearing. Replace corroded or pitted bearing. Revolve bearing slowly by hand. Replace bearing which has rough or tight spots.

- (3) Inspect all gears for nicked, cracked, scored, broken, or worn teeth. Remove burrs or nicks from gear teeth with a soft honing stone or crocus cloth (item 4, Appendix E). Replace badly damaged or worn gears.

- (4) Inspect seals for damage. Replace worn or damaged seals.

d. *Assembly (Fig. 6-9).*

- (1) Install ring seal (16) onto lower leg (10).

- (2) Install screw bushing (15) and thrust bearing (14) onto shaft of lower leg. Coat bearing with grease (item 11, Appendix E).

- (3) Slide lower leg into upper leg until thrust bearing (14) is seated against internal bracket inside of upper leg.

- (4) Install screw bushing (13) onto shaft of lower leg.

- (5) Install bevel gear onto shaft and align key ways. Install key (12).

- (6) Push pinion shaft (4) through seal (6) until it protrudes into the upper leg. Install washer (8) and pinion gear (7) onto the pinion shaft. Push shaft through other seal (6).

- (7) Align holes in pinion shaft and pinion gear, and install roll pin (3). Be sure pinion gear (7) meshes with the bevel gear (11).

(8) Slide washer (8) up against bushing inside upper leg, and install roll pin (2).

(9) Coat grease (item 17, Appendix E) heavily on pinion and bevel gear teeth.

(10) Apply a continuous 1/8-inch diameter bead of adhesive to inside of cover (1). Install cover (1) to upper leg (5).

e. *Installation.* Install landing gear leg (para 4-54).

**6-18. Emergency Valve Control Cables (Fig. 6-10)**

a. *Removal.*

(1) Remove nut (3) and loosen u-bolt connections (9) securing cable(s) to valve operator A. Remove cables.

(2) Loosen U-bolt connection securing cable to emergency valve.

(3) Loosen U-bolt securing control cable to emergency valve shut-off on curbside of trailer and remove cable.

(4) On M970, M970A1 only, loosen the U-bolt connection securing cable to cabinet door shut-off lever. Remove cable.

(5) Pull cables through cable guides and remove cables.

b. *Installation.*

(1) Slide nut (3) over one end of the 120-inch cable. Insert end of cable into end of adjusting bolt (4) and tighten nut onto adjusting bolt.

(2) Thread cable through cable guide on cabinet and U-bolt connection on emergency valve.

(3) Adjust cable (para 4-51).

(4) Connect the 168-inch cable to U-bolt connection on valve operator A.

(5) Thread cable through cable guides and connect to emergency valve shut-off.

(6) Adjust cable (para 4-51).

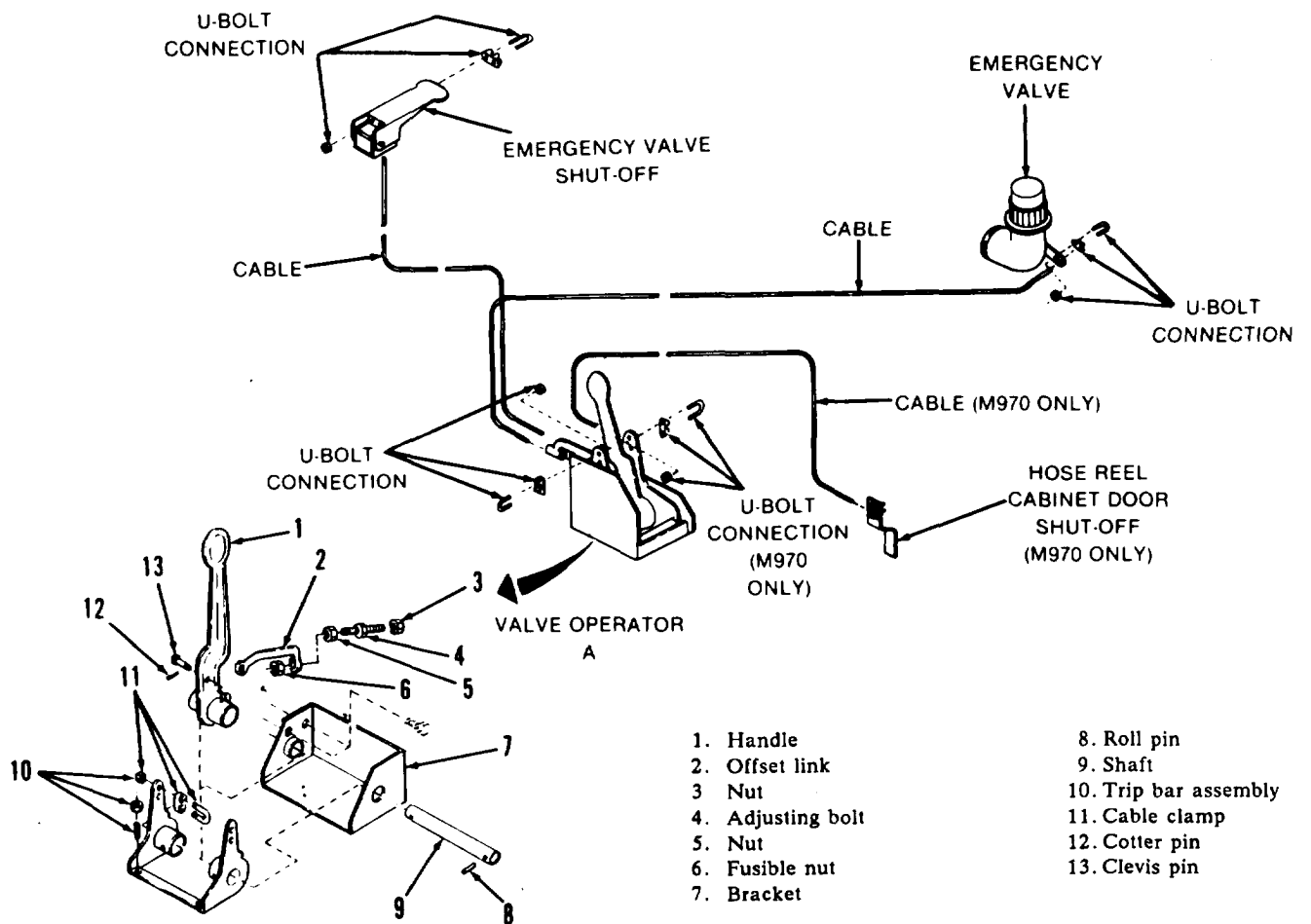

Figure 6-10. Emergency Valve Control and Cables.

TA502306

(7) On the M970 and M970A1 only, connect the 75-inch cable to the U-bolt connection on valve operator A.

(8) Thread cable through cable guide on cabinet and connect cable to hose reel cabinet door shut-off.

(9) Adjust cable (para 4-51).

(10) Cut excess cable 1½-inches from all U-bolt connections.

**WARNING**

**Do not use an acetylene torch to fuse cable ends unless tank has been cleaned and purged. Failure to follow this warning may result in serious injury or death to personnel.**

(11) Unless the tank has been cleaned and purged for other maintenance, crimp the cable ends to keep them from unraveling. DO NOT fuse them unless tank has been purged.

**6-19. Tank Components**

a. *Cleaning and Purging.* Observe safety precautions given in the Warning Summary at front of manual. Do not

attempt to inspector repair tank until it has been drained and purged (Chapter 4, Section XX).

b. *Inspection.* Inspect tank for leaks, punctures, or dents.

c. *Repair.* Straighten dented metal with rubber mallet or a block of wood and heavy hammer. Repair cracks by welding (TM 9-237).

**6-20. Alternator Drive Belt (M967, M969, and M970)**

a. *Removal* (Fig. 6-11).

(1) Remove alternator (para 4-78).

(2) Check pulley in pump intermediate housing to ensure that the two bolts attaching flex plates to pulley are accessible for removal. If bolts cannot be removed, remove center plug from engine grille (fig. 6-12). Use a 5/8-inch socket on a long extension, and insert it through the hole and onto fan bolt. With a socket wrench, turn engine clockwise until bolts can be removed.

(3) Remove two bolts and four washers holding flex plates to pulley.

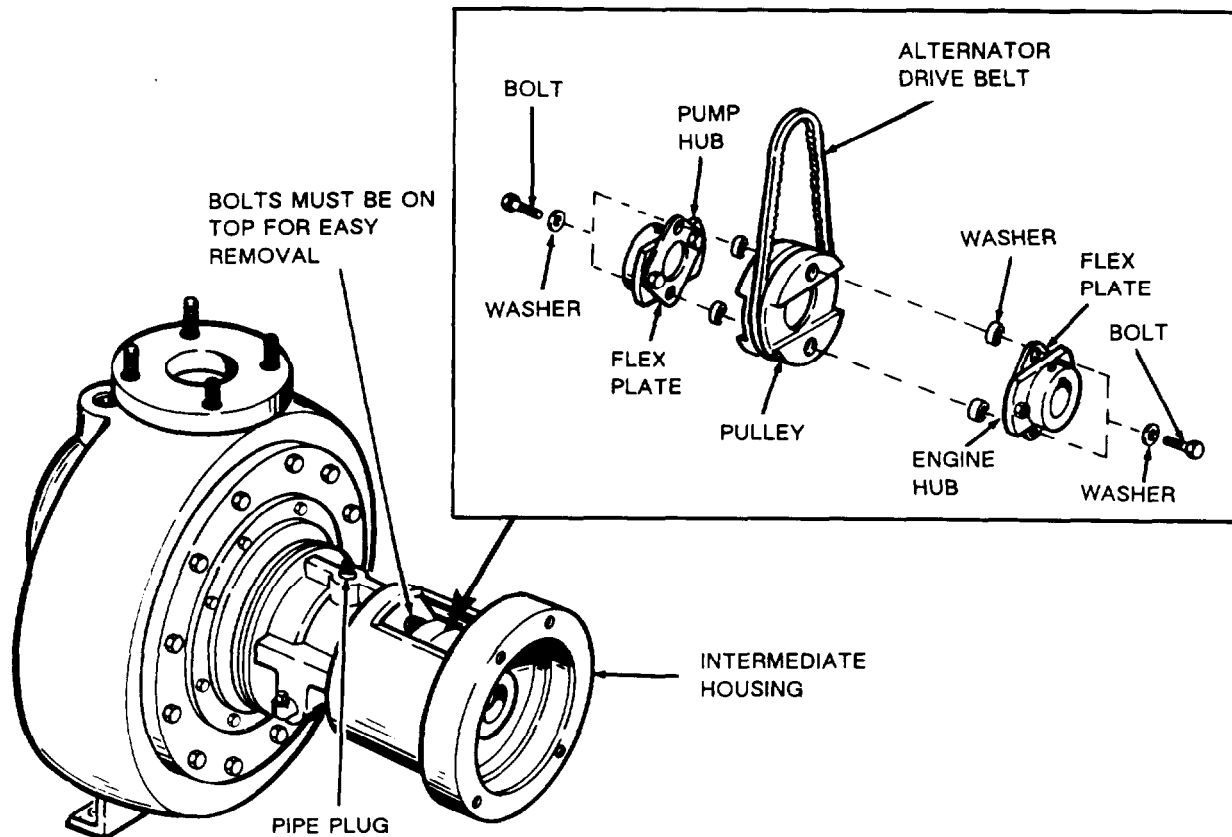

Figure 6-11. Removal of Alternator Drive Belt (M967, M969, and M970).

TA100071

(4) Using the 5/8-inch socket, extension, and socket wrench, turn engine clockwise until the two remaining bolts can be removed.

(5) Remove the two remaining bolts and washers.

(6) Using alternator belt, lift pulley out of intermediate housing and remove belt.

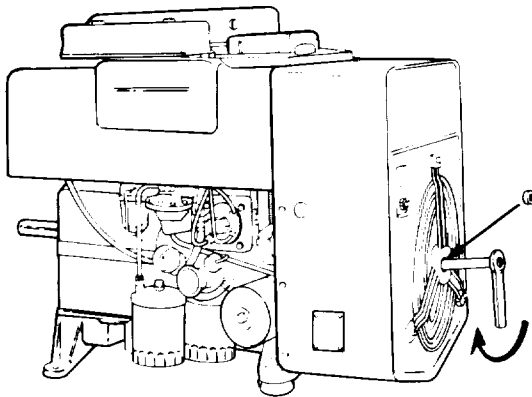

TA100072

**Figure 6-12. Turning Engine in Crankshaft Clockwise Direction.**

b. *Installation* (Fig. 6-11).

(1) Position alternator drive belt on pulley.

(2) Position pulley and belt in intermediate housing between the two hubs.

**CAUTION**

**Be sure curved side of washers are against flex plates. Bolts holding pulley to flex plates must be tightened to 25 lb.-ft.**

(3) Apply thread sealant to two holes, and install two bolts and four washers to hold flex plates to pulley. Tighten bolts to 25 lb.-ft.

(4) Turn engine clockwise until the remaining two bolts and four washers can be installed.

(5) Apply thread sealant to two remaining bolts, and install two bolts and four washers. Tighten bolts to 25 lb.-ft.

(6) Install alternator drive belt over alternator pulley.

(7) Install alternator and adjust drive belt tension (para 4-78).

**6-21. Buss Bar**

a. *Removal.* Refer to paragraph 4-81.

b. *Replacement of Fuse Clip* (Fig. 6-13).

(1) Use a bench grinder to remove crimped end of rivet.

(2) Use a hammer and punch to drive rivet from buss bar and fuse clip.

(3) Install fuse clip to the buss bar with a rivet. Use a rivet punch to install rivet.

c. *Installation.* Refer to paragraph 4-81.

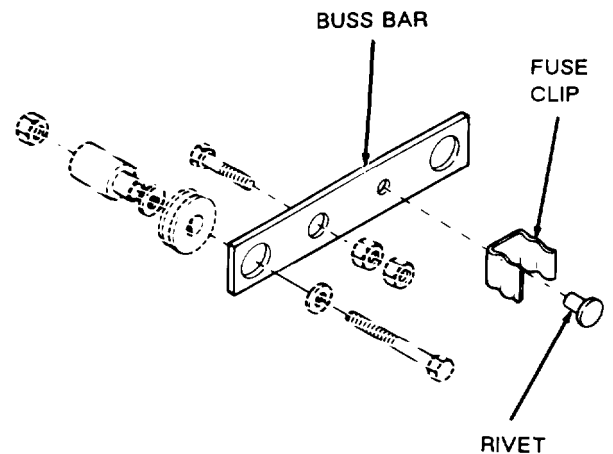

TA502335

**Figure 6-13. Installing Fuse Clip.**





# CHAPTER 7 REPAIR OF ENGINE ASSEMBLY

## Section 1. DESCRIPTION AND SPECIFICATIONS

### 7-1. Scope

a. This chapter contains instructions for direct and general support maintenance of the engine and related parts which are beyond the scope of using organization.

b. The terms right, left, front, and rear used in this technical manual, with reference to the engine and its components, are determined as viewed from the front or flywheel end of engine.

### 7-2. General

a. The diesel engine assembly, Model DJCMS 4118W (fig. 5-9) is a 4-cylinder, 4-cycle, valve-in-head, aircooled engine.

b. The engine is used as a power source to drive a pump assembly for fueling and defueling operations.

c. Physical and technical characteristics are tabulated in table 7-1.

d. The following systems and components comprise the Model DJCMS 4118W Diesel Engine:

- (1) Air cooling system (para 7-3)
- (2) Fuel system (para 7-4)
- (3) Lubrication system (para 7-5)
- (4) Starting system (para 7-6)
- (5) Charging system (para 7-7)
- (6) Governor system (para 7-8)
- (7) Power train (para 7-9)

### 7-3. Air Cooling System (Fig. 7-1)

a. The engine has a pressure air cooling system. Fins on the engine blower (flywheel) draw air into the front of the engine housing and force it past the cylinders and out the right side of the engine.

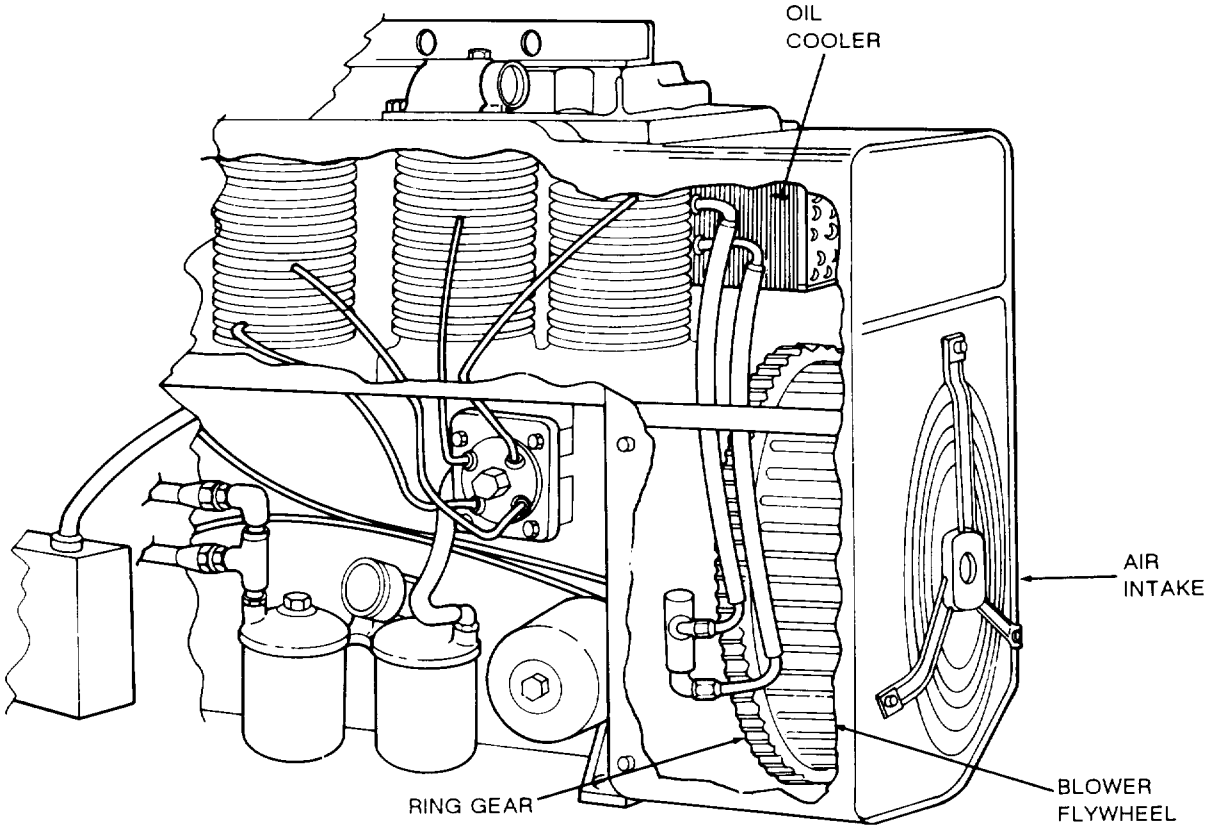

Figure 7-1. Air Cooling System.

TA502320

b. A thermostatic element controls shutter opening which limits air flow when the engine is cold.

c. When the engine air temperature reaches approximately 120°F (49°C) the shutter begins to open.

The shutters are completely open at 140°F (60°C) under full-rated load.

**7-4. Fuel System (Fig. 7-2)**

a. The engine fuel system consists of two pressure systems: the low pressure system and the high pressure system.

b. In the low pressure system, two fuel pumps (in series) draw fuel from the fuel tank and force the fuel through two fuel filters to the injection pump.

c. In the high pressure system, the fuel injection pump forces fuel, under high pressure, to the fuel injection nozzles.

d. The injection nozzles provide fuel to each combustion chamber of the engine. A small quantity of unused fuel is returned from the injectors and injection pump to the fuel tank.

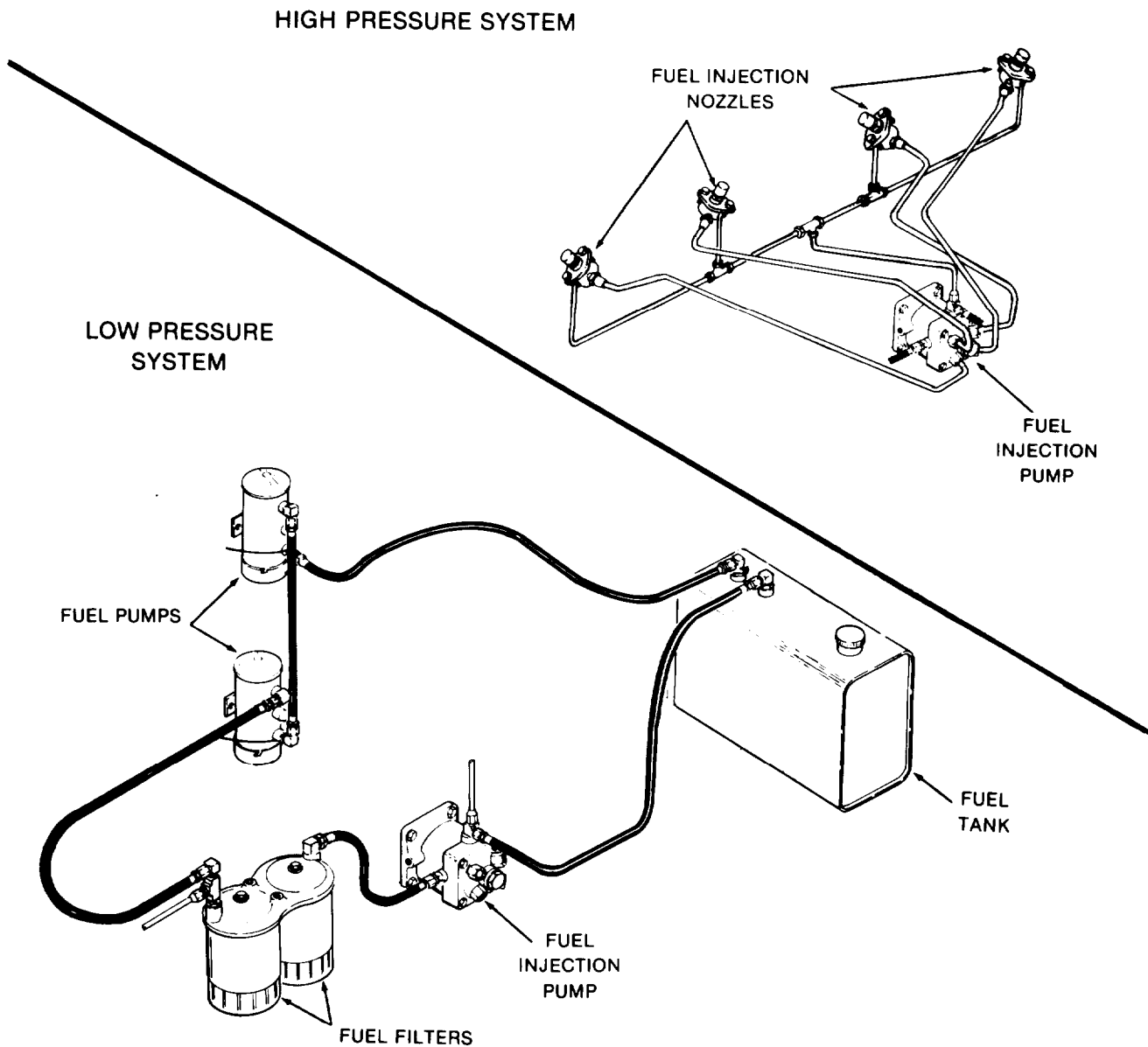

Figure 7-2. Fuel System.

TA100075

e. A cam and gear on the camshaft drive the fuel injection pump. The gear drives the pump face gear, providing fuel distribution to each cylinder in the proper order. The cam operates the pump plunger, pressurizing fuel to the nozzles.

f. A control sleeve meters fuel by controlling the length of time the plunger spill port is closed, maintaining pressure, and therefore, the amount of fuel delivered in each stroke.

g. The pintle-type injection nozzles are conventional inward opening with adjustable opening pressure. They are factory adjusted to open at 1900-1950 psi.

**7-5. Lubrication System (Fig. 7-3)**

a. The diesel engine has pressure lubrication to all working parts.

b. The oil system includes oil intake cup, gear-type oil pump, bypass valve, oil pressure gage, low oil pressure shut-off, full-flow oil filter, oil cooler, and passages to deliver oil throughout the engine.

c. Oil is held in the oil base, and forced through the oil filter and oil cooler by the pump.

d. Lines leading to the recker housing, passages through the block to crankshaft and to front camshaft bearing, crankshaft passages to connecting rod bearings, and connecting rod passages to piston pin bushings complete the oil system network.

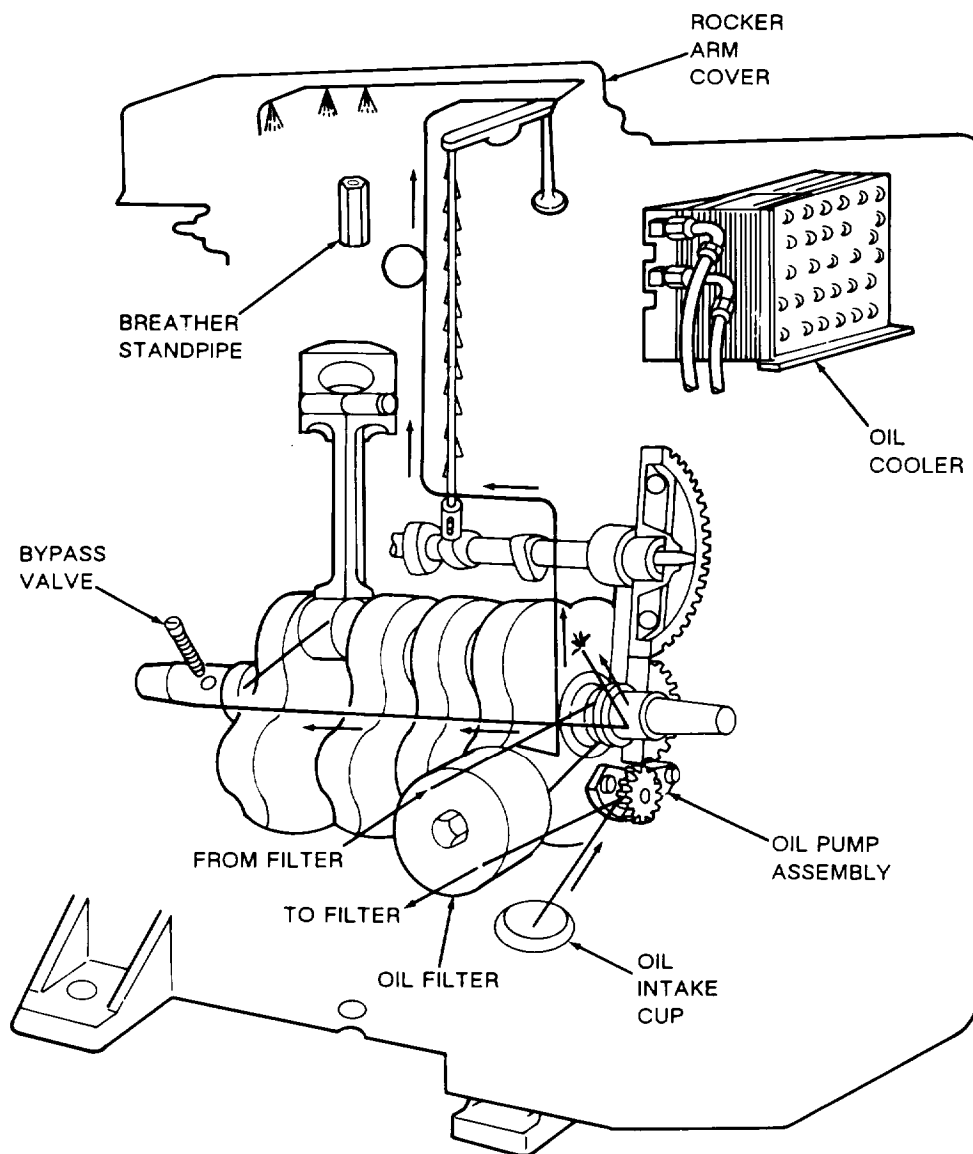

Figure 7-3. Lubrication System.

TA502321

e. The bypass valve controls oil pressure by allowing excess oil to flow directly back to the crankcase.

**7-6. Starting System (Fig. 7-4)**

- a. The engine is cranked by a 12V starting motor.
- b. When the solenoid of the starting motor is energized, the solenoid core pulls inward and shifts the pinion into engagement with the ring gear on the engine flywheel.

c. An overrunning clutch protects the starting motor from overspeeding by the engine.

d. The energized solenoid also closes a set of contacts to provide a circuit for the starting motor.

e. The starting motor remains engaged until the starting switch is released by operator.

f. Refer to paragraph 2-10 for starting and operating procedures.

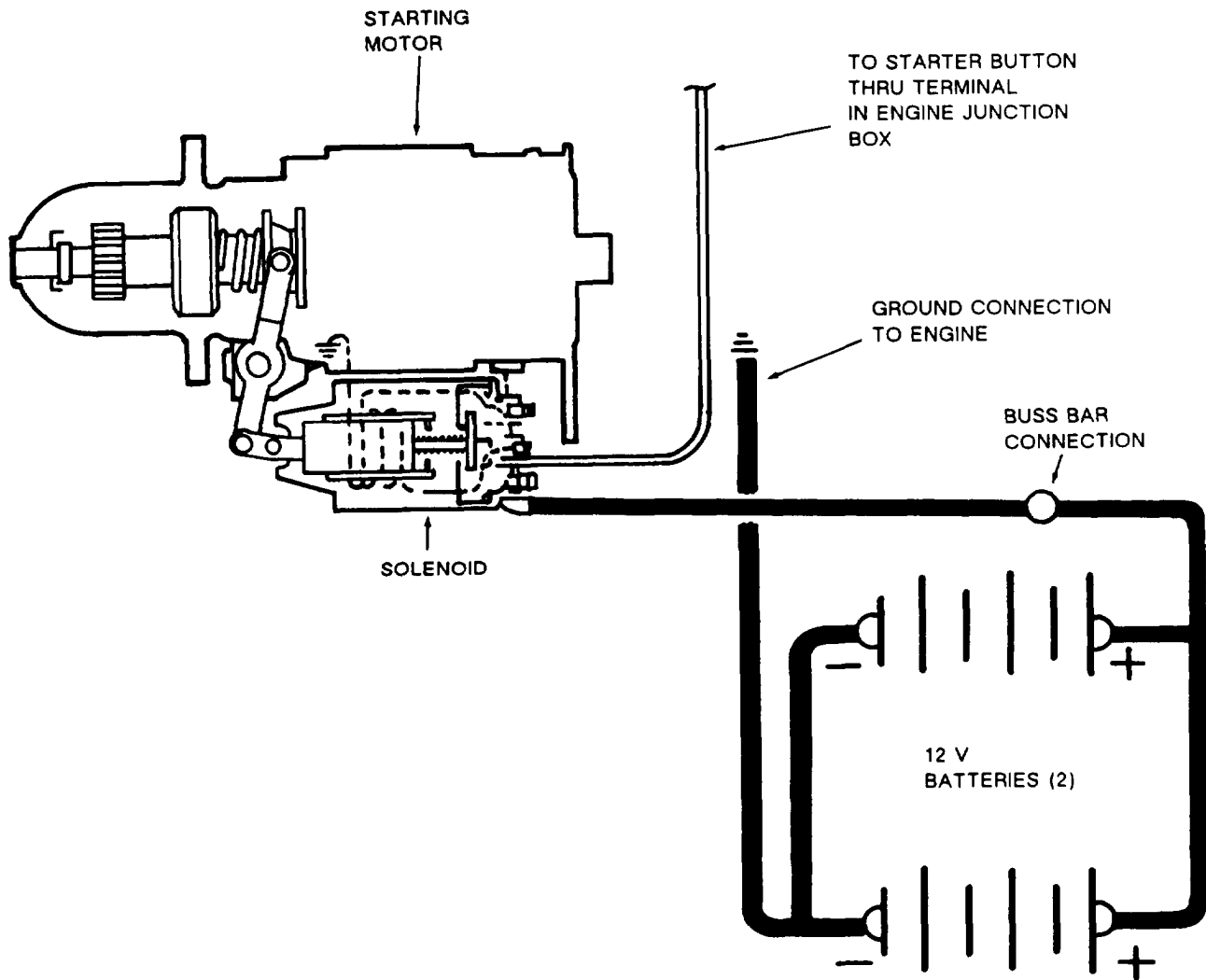

TA100077

*Figure 7-4. Starting System.*

## 7-7. Charging System (Fig. 7-5)

### CAUTION

**Instantaneous damage will be caused to the voltage regulator if system polarity is reversed. Installing a battery backwards, boosting or jump starting with jumper connected backwards, or reversing the positive (+) and negative (-) output leads of the alternator will damage the regulator. Although the polarity reversal may only be momentary, and may not damage the alternator diodes, the voltage regulator will still be damaged.**

#### a. Description.

(1) The charging system supplies approximately 14V of direct current for recharging the batteries and operating the components of the engine electrical system.

(2) The system includes two 12V batteries connected in parallel, an alternator with integral voltage regulator, a voltmeter, and wiring to connect these components together.

(3) The self-load-limiting alternator has a built-in solid state voltage regulator.

(4) The voltage regulator is a "J"-type regulator equipped with transient voltage protection to withstand instantaneous opening of the charging circuit under full-load conditions.

#### b. Operation.

(1) The alternator is belt driven off the pump drive coupling.

(2) As the rotor (field) of the alternator turns inside the stator, an alternating current is made in the stator windings. The current is rectified or changed into direct current by positive and negative diodes fastened to the stator.

(3) The direct current leaves the alternator at the positive output terminal and is sent to the batteries.

(4) Alternator output is controlled by the voltage regulator.

(5) The voltage regulator senses the difference between battery voltage and output voltage and regulates the amount of current that is sent to the field windings in the alternator according to the demand from the batteries.

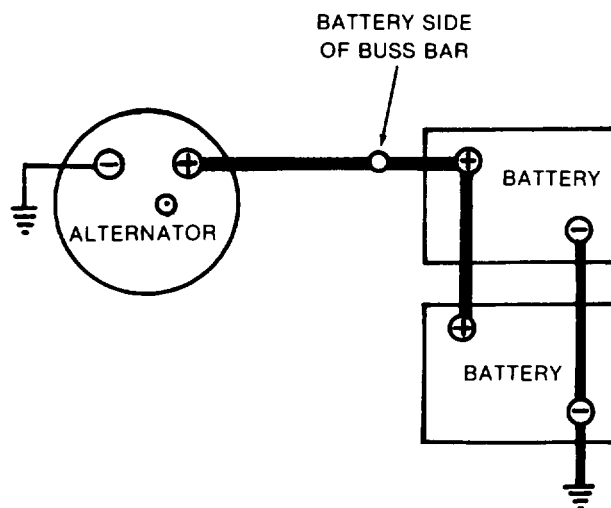

TA100078

Figure 7-5. Charging System.

## 7-8. Governor System (Fig. 7-6)

a. The purpose of the engine governor is to maintain a constant engine speed during changes in power demands. The governor responds to changes in power demands by varying the throttle position.

b. The constant-speed governor maintains engine speed up to 2400 rpm. The speed-sensing device is a ball and cup mechanism on the camshaft gear. A yoke, resting on the cup, is connected to the governor arm which, in turn, is connected to the throttle lever. Any change in engine speed is transmitted from the cup to the yoke, and then to the throttle.

c. Tension on the governor spring determines the speed at which the engine is governed. A stud screwed into the spring is used to vary the number of effective cots for getting the desired sensitivity-the speed drop from no-load to full-load.

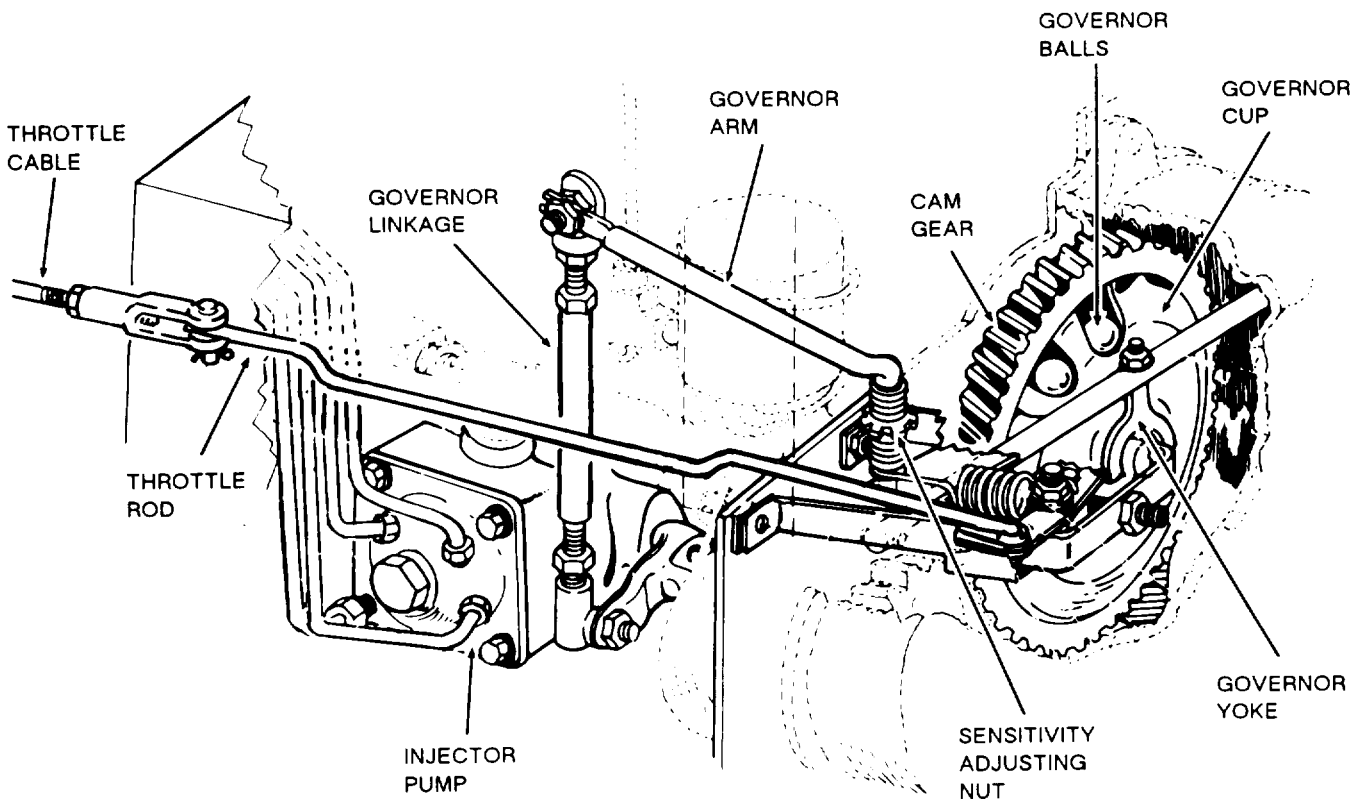

**Figure 7-6. Governor System.**

TA100079

**7-9. Power Train (Fig. 7-7)**

The power train includes the cylinder head and cylinder block assemblies:

*a. Cylinder Head Assembly.*

(1) The cylinder head assembly consists of the intake and exhaust valves, valve springs, rocker arms, shields, push rods, injection nozzles, and glow plugs.

(2) The valve lifters are driven by the camshaft, and transfer motion to the intake and exhaust valves through the push rods and the rocker arms.

(3) When the push rod moves down, the valve spring forces the valve to close against the valve seat and seal off the combustion chamber.

(4) The valve opening and closing is timed by the camshaft gear and crankshaft gear. The sequence is as follows:

(a) Intake open, exhaust closed: Air is drawn into cylinder while piston is moved down.

(b) Intake closed, exhaust closed: Piston moves upon compression stroke. Ignition occurs near top dead center when fuel is injected.

(c) Intake closed, exhaust closed: Piston moves down on power stroke, transferring force to crankshaft.

(d) Intake closed, exhaust open: Piston moves up, forcing burned gases out of open valve to exhaust system.

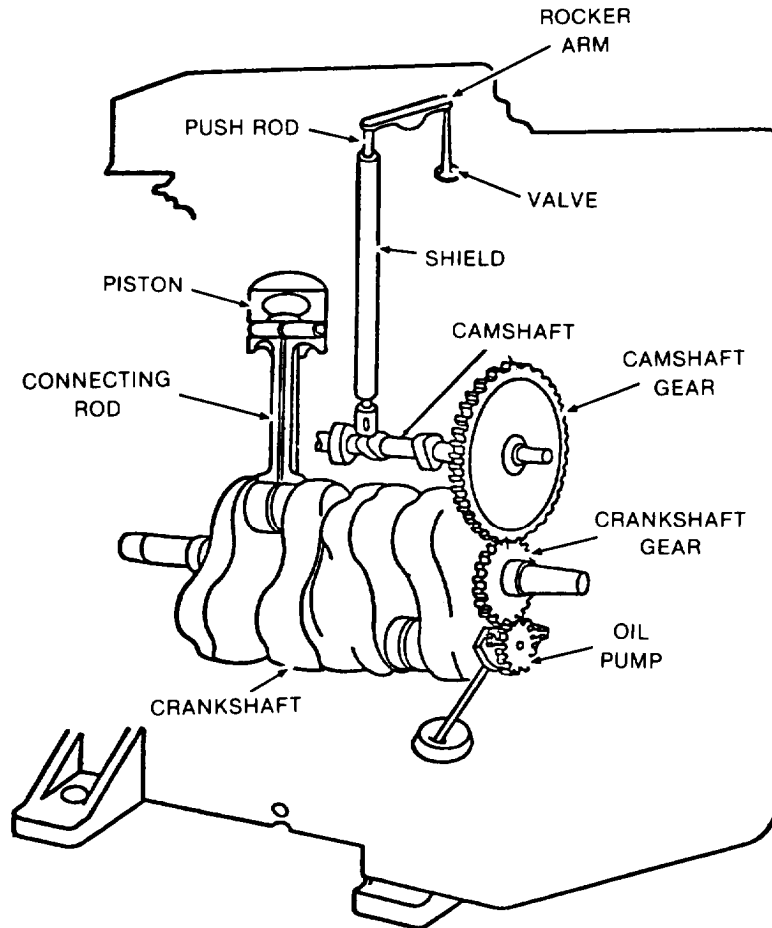

TA100080

Figure 7-7. Power Train.

*b. Cylinder Block Assembly.*

(1) The cylinder block houses the crankshaft, pistons, camshaft, and oil pump.

(2) The crankshaft rotates on front center and rear main bearings, and has a flywheel (fig. 7-1) on one end and the power takeoff shaft on the other.

(3) A gear, located on the crankshaft, drives the camshaft and oil pump.

(4) Power is supplied to the crankshaft by the four pistons and the connecting rods.

(5) A ring gear (fig 7-1), mounted on the flywheel, is engaged by the starter motor pinion gear when the starter solenoid relay is energized.

## 7-10. Specifications and Tolerances

*a. Tabulated Data.*

(1) Table 7-2 itemizes the dimensions and clearances applicable to the DJCMS diesel engine components. The dimensions and clearances shown are for new parts.

(2) Where greater tolerances are allowed, they will be shown in the applicable maintenance paragraph.

*b. Torque Specifications.* The torque values shown in table 7-3 will ensure proper tightness without danger of stripping threads.

**Table 7-1. Physical and Technical Characteristics, Model DJCMS Diesel Engine.**

**Physical Dimensions:**

Height .....26 in.  
 Width .....19.5 in.  
 Length .....34.5 in.  
 Weight .....440 lb. (approx.)

**Physical Characteristics:**

Number of cylinders .....4  
 Displacement .....120 cu. in.  
 Horsepower at 2400 rpm ..... 27.5  
 Governor setting ..... 2400 rpm+/-100  
 Ignition order of cylinders .....1,2,4,3  
 Bore .....3.250 in. dia.  
 Stroke .....3.625 in.  
 Compression ratio ..... 19:1  
 Oil capacity, including 1/2quart  
 for filter ..... 6 1/2 quarts  
 Fuel, diesel ..... Fed. SpecVV-F-800

**Electrical Characteristics:**

Batteries ..... 2, connected in parallel  
 Battery voltage .....12 Vdc

**Miscellaneous Data:**

Cooling air at 2400 rpm ..... 11135 cu. ft./min.  
 Fuel pump lift ..... .6ft./max.  
 Combustion air at 2400 rpm ..... .64 cu. ft./min.

**Power Takeoff**

Shaft length .....4in.  
 Shaft diameter ..... 1.75 in.  
 Keyway length .....3 in.  
 Keyway width .....0.375 in.  
 Keyway depth .....0.188 in.

**Starting Aids:**

Starting motor ..... 12V  
 Glow plug .....4  
 Manifold heater .....2

**Table 7-2. Repair and Replacement Standards.**

*(All values in inches unless otherwise specified.)*

Component	Manufacturer's Dimensions and Tolerances		Maximum Allowable Wear Limit
	Minimum	Maximum	
<b>CAMSHAFT</b>			
Beating journal diameter -front	2.500	2.505	0.002
Bearing journal diameter- rear	1.1875	1.1880	0.002
Bearing clearance limit	0.0012	0.0037	0.0057
Camshaft end play	0.007	0.039	0.045
Cam tappet hole diameter	0.7505	0.7515	N/A
Cam tappet diameter	0.7475	0.7480	N/A
<b>CONNECTING RODS:</b>			
Largebearingbore	2.1871	2.1876	2.1886
Small bushing bore	1.044	1.045	1.0455
Length - center to center	5.998	6.002	6.002
Bearing to crankshaft clearance	0.0010	0.0033	0.0040
<b>CRANKSHAFT</b>			
Main bearing journal diameter	2.2430	2.2435	0.001
Crankshaft main bearing clearance	0.0024	0.0049	N/A
Connecting rod journal diameter	2.0600	2.0605	N/A
End play, crankshaft	0.010	0.015	0.015**
<b>CYLINDER BLOCK:</b>			
Cylinder bore	3.2495	3.2505	0.005
Clearance in cylinder bore	0.0050	0.0070	0.005
Bore, piston pin	0.9900	0.9903	0.9903
Ring groove width - top	0.0970	0.0980	0.005
Ring groove width - 2nd & 3rd - compression	0.0965	0.0975	0.005
Ring groove width - 4th - oil control	0.1880	0.1895	0.005



**Table 7-2. Repair and Replacement Standards (Con't).**

**(All values in inches unless otherwise specified.)**

Component	Manufacturer's Dimensions and Tolerances		Maximum Allowable Wear Limit
	Minimum	Maximum	
PISTON PIN: Length Diameter Piston clearance Connecting rod bushing clearance	2,753 0.9699 Thumb push fit 0.0002	2.756 0.9901 0.007	N/A 0.001 0.0006
PISTON RING: Clearance in groove - top Clearance in groove - 2nd & 3rd - compression Clearance in groove - 4th - oil control Gap	0.0035 0.0030 0.0020 0.0100	0.0075 0.0050 0.0030 0.0200	0.0100 0.0080 0.0050 0.0400
VALVE, INTAKE: Stem diameter Stem guide clearance Stem to rocker arm clearance Seat diameter in head Top of valve recessed below cylinder head deck Seat width Valve seat angle Valve face angle	0.3415 0.0025 Cold 0.008 1.361 0.433 0.0468 45° 42°	0.3410 0.0028 1.362 0.439 0.0625 N/A N/A	N/A N/A 0.0005 N/A 0.500 N/A N/A N/A
VALVE, EXHAUST Stem diameter Stem guide clearance Stem to rocker arm clearance Seat diameter in head Top of valve recessed below cylinder head deck Seat width Valve seat angle Valve face angle	0.3415 0.0045 0.007 1.361 0.433 0.0466 45° 45°	0.3410 0.005 1.362 0.439 0.0625 N/A N/A	N/A N/A 0.0005 N/A 0.500 N/A N/A N/A
VALVE GUIDE: Length Outside diameter Bore diameter - intake - reamed Bore diameter - exhaust - reamed	1.7812 0.4690 0.3425 0.3445	0.4695 0.3435 0.3455	0.4695 0.003 0.003
VALVE LIFTER: Body diameter overall length Lifter bore	0.8725 1.510 0.8755	0.8730 1.550 0.8765	0.003 1.500 0.006
VALVE SPRINGS - INTAKE & EXHAUST Free length Total coils Length, valve closed Length, valve open Load, valve closed Load, valve open	1.875 5.75 1.528 1.214 45 lb. 83 lb.	49 lb. 93 lb.	N/A N/A N/A N/A 40 lb. N/A
CYLINDER HEAD. Warpage (longitudinally) Warpage (laterally)		0.001 0.001	0.0015 0.0015

\* Replacement bearing only

\*\* Shim controlled

**Table 7-3. Torque Values.**

Item	Torque Range (Lb. -Ft.)	
	Minimum	Maximum
Center main bolt	97	102
Connecting rod bolt	27	29
Rocker-box cover	8	10
Cylinder head bolt	44	46
Exhaust manifold nuts	13	*15
Flyweel mounting screw	65	70
Hub to flywheel.screws	17	21
Fuel pump mounting screws	15	20
Gear case cover	15	20
Glow plug	10	15
Injection nozzle mounting screws	20	21
Injection pump mounting screws	15	16
Intake manifold	13	15
Oil base mounting screws	45	50
Oil pump mounting screws	15	20
Rear bearing plate	40	45
Rocker arm nut	4	**10
Rocker arm stud	35	40

\* Exhaust nuts must be tightened evenly.

\*\* This torque is due to friction between the threads only and locks the nuts in place. Use the rocker arm nut to adjust valve lash.

**Section II. REMOVAL AND INSTALLATION OF MAJOR COMPONENTS**

**7-11. General**

a. This section contains step-by-step procedures for removal and installation of the auxiliary engine major components and subassemblies.

b. Do not disassemble the engine beyond the procedures described in this chapter.

c. Any further breakdown of the major components or subassemblies for repair of the engine will be found under the appropriate headings in Section III, Repair Instructions.

**7-12. Preparation**

Prior to disassembly of the engine, the following conditions should be established.

a. Provide a clean work area. Many diesel engine parts are intolerant of even minute particles of dirt. A clean area is required for placement of parts as they are removed.

b. Ensure availability of proper cleaning materials such as solvents, lint-free cloths, soft brushes, pans, waste containers, etc. Do not use volatile solvents for cleaning. Diesel fuel is a suitable cleaning solvent, but must be handled and stored properly.

c. Refer to table 5-1, Special Tools, Test and Support Equipment, and ensure that the necessary tools are available. Always use the right tool for the job; do not improvise.

**7-13. Removal Procedures**

a. General.

(1) Using clean rags and diesel fuel, remove all grease, oil, and dirt from the engine prior to disassembly.

(2) Remove drain plug and drain crankcase oil completely. Tip engine toward drain plug side while draining.

(3) Drain fuel from fuel lines and empty the fuel sediment bowl.

b. Removal.

(1) The following paragraphs contain the instructions necessary to disassemble the engine to replace damaged or worn components. If each procedure is followed in order, the engine will be disassembled for complete overhaul.

(2) Prior to assembly of the engine, certain inspections and repairs should be accomplished as described in Section IV, Test and Adjustments.

**7-14. Air Cooling Shrouding**

a. *Top Air Housing Covering (2, Fig. 7-9).*

(1) Remove muffler (para 4-77).

(2) Disconnect air cleaner hose at the air intake manifold (para 4-74).

(3) Remove five capscrews (1, fig. 7-10) and nuts (2) to securing muffler stand (3) to panels (4 and 5).

(4) Remove capscrew (7, fig. 7-9) and spacer (8) from the lifting bracket brace (9). Remove two capscrews (13), washers (14), vibration cushions (15), and spacers (16). Remove lifting bracket (17) and lifting bracket brace (9).

(5) Remove four capscrews (18) and washers (19) and remove top air housing cover (2).

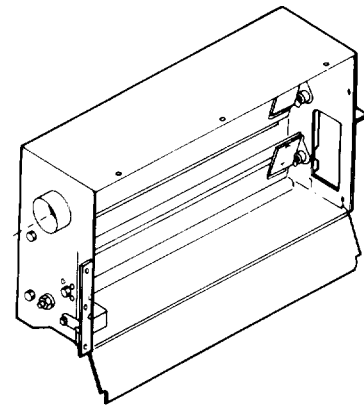

TA502322

**Figure 7-8. Shutter Assembly.**

- |                          |                           |                         |
|--------------------------|---------------------------|-------------------------|
| 1. Rear cylinder housing | 13. Capscrew (2)          | 24. Capscrew (2)        |
| 2. Top air housing cover | 14. Washer (2)            | 25. Washer (2)          |
| 3. Bottom cylinder pan   | 15. Vibration cushion (2) | 26. Capscrew            |
| 4. Cover panel           | 16. Spacer                | 27. Screw (2)           |
| 5. Grille                | 17. Lifting bracket       | 28. Capscrew (3)        |
| 6. Blower housing        | 18. Capscrew (4)          | 29. Washer (3)          |
| 7. Capscrew              | 19. Washer (4)            | 30. Capscrew (2)        |
| 8. Spacer                | 20. Capscrew              | 31. Grille retainer (3) |
| 9. Lifting bracket brace | 21. Capscrew (3)          | 32. Capscrew            |
| 10. Capscrew             | 22. Lockwasher (3)        | 33. Lockwasher          |
| 11. Lockwasher           | 23. Capscrew (8)          | 34. Baffles (2)         |
| 12. Nut                  |                           |                         |

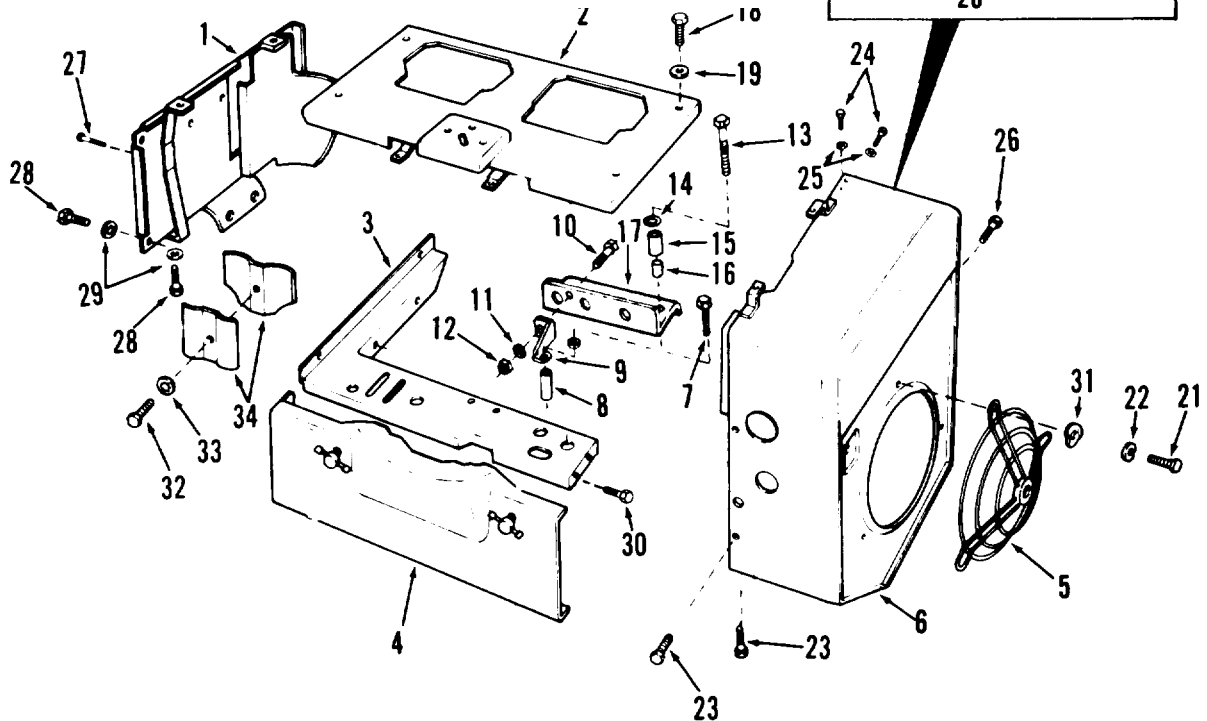

TA100082

**Figure 7-9. Blower Housing and Air Shrouding**

b. Blower Housing (6, Fig. 7-9).

**NOTE**

**To remove blower housing only, the top air housing cover (2, fig. 7-9) need not be removed. The two capscrews (18) and washers (19) securing air housing cover to blower housing must be removed to remove blower housing.**

(1) Disconnect air cleaner hose at the engine air intake manifold, if not previously removed (para 4-74).

(2) Disconnect the fuel hoses from the fuel tank (para 4-73). Pull hoses through holes in engine fan shroud (8, fig. 7-10).

(3) Remove four screws (6, fig. 7-10) and nuts(7) securing engine fan shroud (8) to frame (9) and panel (5). Remove engine fan shroud.

(4) Loosen capscrew (20, fig. 7-9), but do not remove.

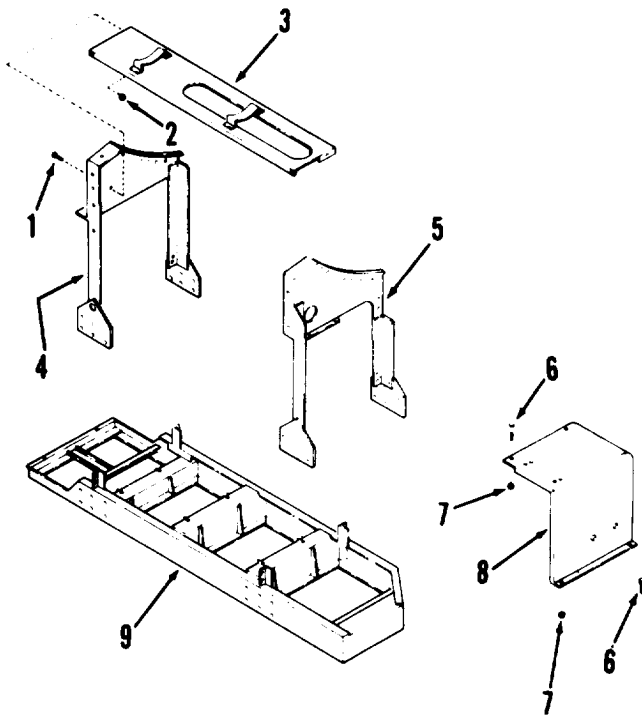

- 1. Capscrew (5)
- 2. Nut (5)
- 3. Muffler stand
- 4. Panel
- 5. Panel

- 6. Screw (4)
- 7. Nut (4)
- 8. Fan shroud
- 9. Frame

TA100C83

**Figure 7-10. Removal of Muffler Stand and Fan Engine Shroud.**

(5) Remove top capscrew (21), lockwasher (22), and grille retainer (31) from the blower housing grille (5).

(6) Remove eight capscrews (23), two capscrews- (24), two washers (25), and capscrew (26). Remove blower housing (6).

c. Air Shutter (Fig. 7-8).

(1) Remove the high temperature switch (para 7-17).

(2) Pull high temperature switch leads out through hole in air shutter box.

(3) If blower housing was not previously removed, remove two capscrews (29, fig. 7-44).

(4) Remove three capscrews (30) and washers (31), and remove air shutter assembly. Remove forward rocker cover for clearance.

d. Rear Cylinder Housing (1, Fig. 7-9).

(1) Remove throttle cable only at engine (para 4-75).

(2) If air shutter was not previously removed, remove three capscrews (30, fig. 7-44).

(3) Remove two screws (27, fig. 7-9), three capscrews (28), and three washers (29). Remove rear cylinder housing (1).

e. Bottom Cylinder Pan (3, Fig. 7-9).

**NOTE**

To remove bottom cylinder pan (3, fig. 7-9), the top air housing cover (2), rear cylinder housing (1), and blower housing (6) must be removed.

(1) Disconnect the hot lead from the fuel shutoff solenoid, the two leads from the oil pressure switch, and the nylon tube from the oil pressure switch (para 4-22). Disconnect large lead from the manifold heaters (para 4-20).

(2) Disconnect the governor arm (3, fig. 7-14) from the governor linkage (1) by removing nut (21) from the ball joint (22).

(3) Remove all fuel lines (para 7-19).

(4) Remove two screws (30, fig. 7-9), and remove bottom cylinder pan (3).

**7-15. Oil Cooler and Lines (Fig. 7-11)**

- a. Remove blower housing (para 7-14).

**NOTE**

**Oil cooler and lines maybe filled with oil. Use care to prevent spillage.**

- b. Disconnect oil cooler hoses at valve of oil filter adapter (11).
- c. Drain cooler into a suitable container.

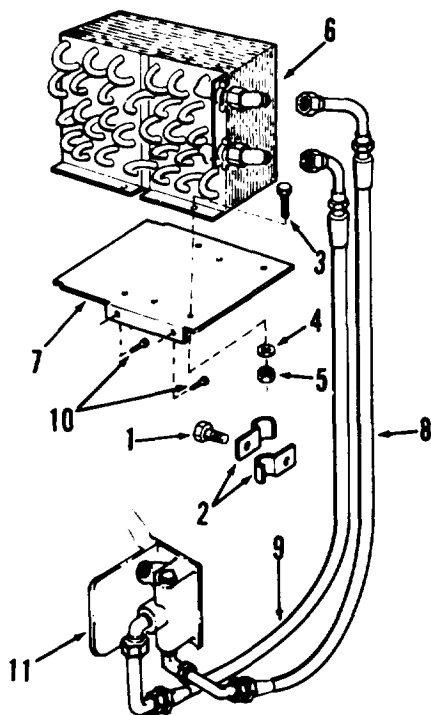

- |                   |                        |
|-------------------|------------------------|
| 1. Capscrew       | 7. Bracket             |
| 2. Clamp (2)      | 8. Hose                |
| 3. Capscrew (4)   | 9. Hose                |
| 4. Lockwasher (4) | 10. Capscrew (2)       |
| 5. Nut (4)        | 11. Oil filter adapter |
| 6. Oil cooler     |                        |

TA100084

**Figure 7-11. Oil Cooler and Lines.**

**CAUTION**

**Do not bend or damage the aluminum cooling fins when removing cooler.**

- d. Remove self-locking screw (1) and two retaining clamps (2).

Remove four capscrews (3), lockwashers (4), and nuts (5) attaching oil cooler (6) to mounting bracket (7), and remove cooler.

**7-16. Tachometer Sensor (M967, M969, and M970) (fig. 7-12)**

- a. Remove blower housing (pars 7-14).
- b. Unscrew bottom jam nut on sensor and remove sensor from mounting bracket. Disconnect two electrical leads from sensor and remove sensor.

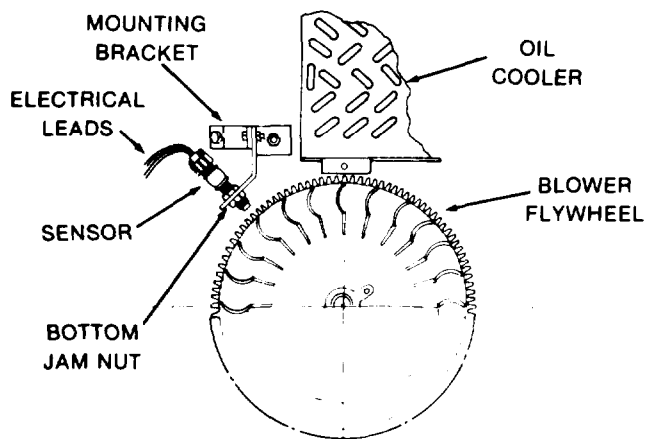

TA100085

**Figure 7-12. Tachometer Sensor**

**7-17. High Temperature Switch (Fig. 7-13)**

- a. Replacement of high temperature switch is done from under the vehicle. The switch is attached to the exhaust manifold behind the air shutter assembly on the left side of engine.
- b. Block open louvers on air shutter.
- c. Tag and disconnect two leads (1 and 2) from high temperature switch (13).
- d. Remove two capscrews (3) and two washers (4) holding switch bracket (10) to the exhaust manifold. Remove bracket with pressure switch attached.
- e. Remove the nut (5), star washers (6), terminal (7), flatwasher (8), insulated washer (9), switch bracket (10), insulated sleeve (11), insulated washer (12), and high temperature switch (13).

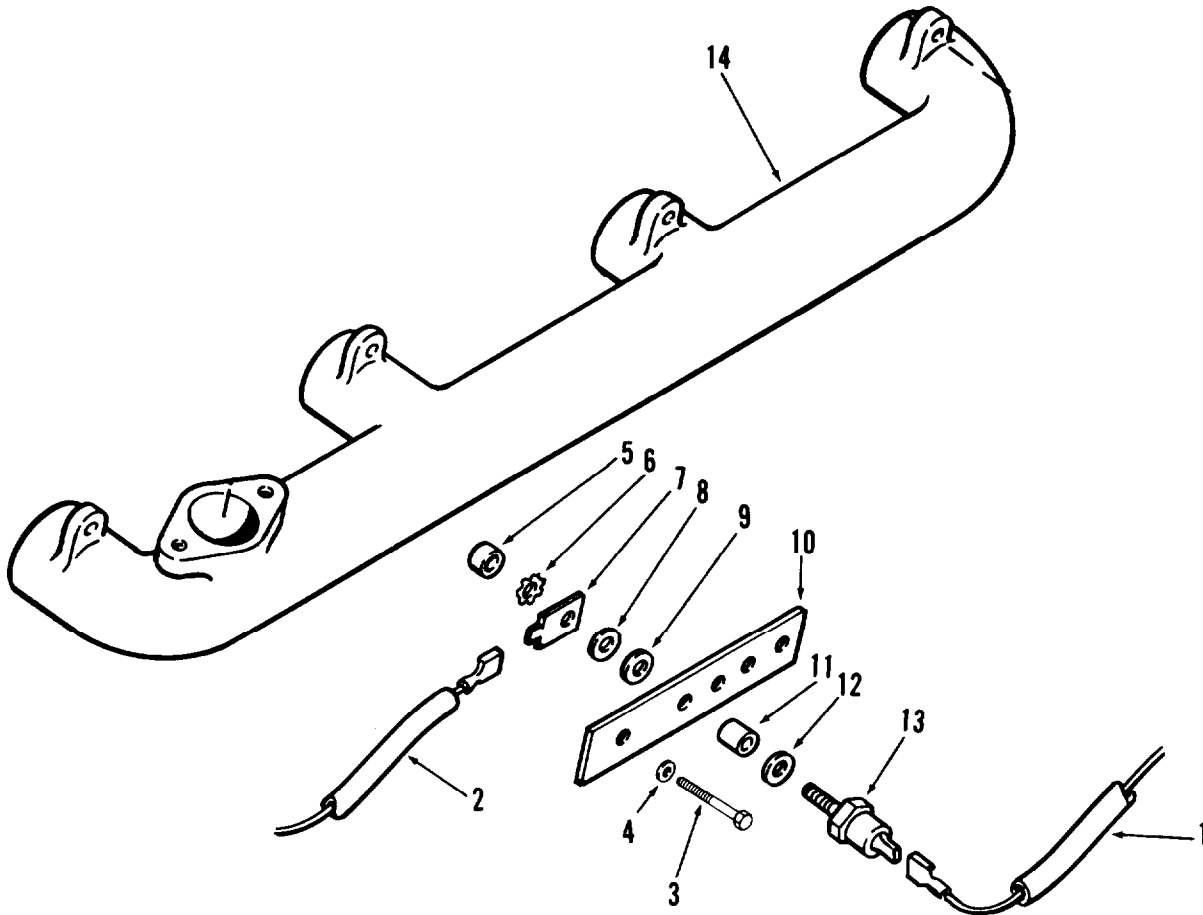

TA099789

Figure 7-13. High Temperature Switch Installation.

**7-18. Governor Linkage (Fig. 7-1 4)**

a. Disconnect governor linkage (1) from injector pump (2) and governor arm (3).

b. Remove spring (17) and disconnect governor arm (3) from governor shaft (4).

c. Remove cotter pin (8) and clevis pin (9), and disconnect yoke (10) from throttle rod (7).

d. Remove cotter pin (5), and remove throttle rod (7) and two washers (20) from control arm (19).

e. Remove bracket (12) from engine back plate by removing two screws (13), lockwashers (14), and nuts (15).

**7-19. Fuel Lines (Fig. 7-15)**

a. Tag and remove injector nozzle return lines (3).

b. Remove manifold (4) and return line (5).

c. Tag and remove injector lines (7).

1. Governor linkage
2. Injector pump
3. Governor arm
4. Governor shaft
5. Cotter pin
6. Pivot
7. Throttle rod
8. Cotter pin
9. Clevis pin
10. Yoke
11. Throttle cable
12. Bracket
13. Screw (2)
14. Lockwasher
15. Nut (2)
16. Ratchet
17. Spring
18. Maximum speed screw
19. Control arm
20. Washer (2)
21. Nut (2)
22. Ball joint

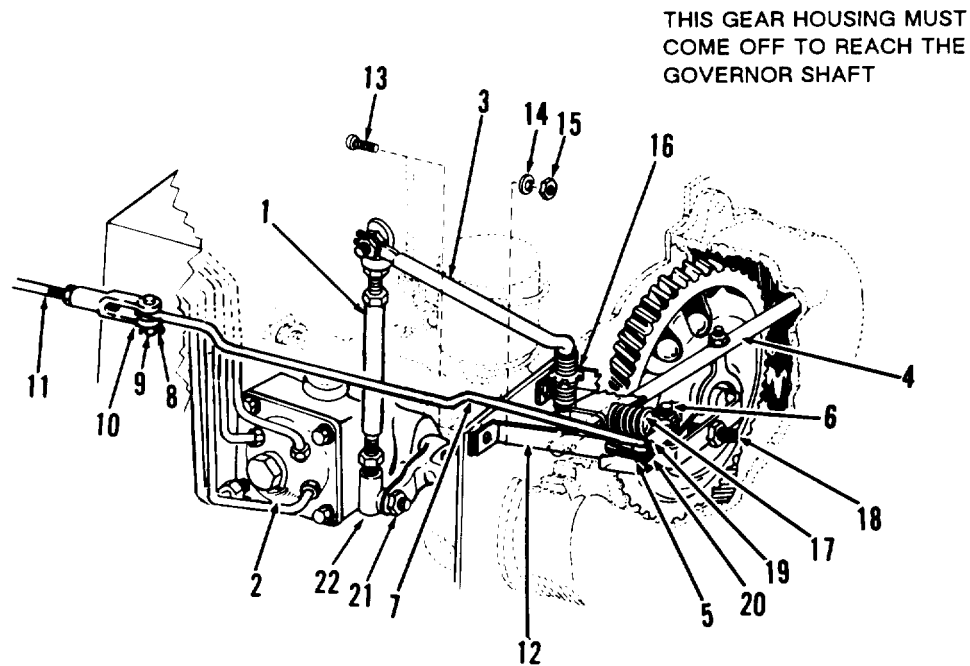

TA100086

Figure 7-14. Speed and Governor Control.

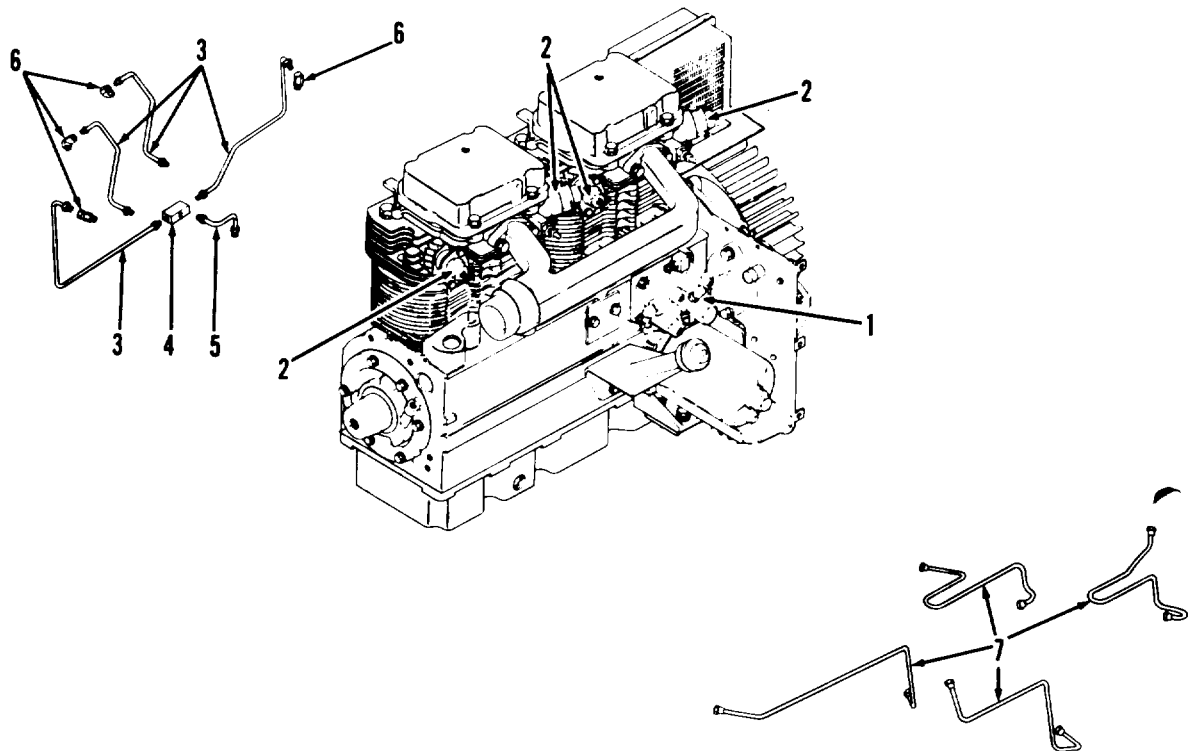

- |   |  |
|---|--|
| 1. Fuel injection pump                    | 5. Fuel line, manifold to fuel pump                  |
| 2. Injector nozzles (4)                   | 6. Fitting (4)                                       |
| 3. Fuel lines, injector nozzle return (4) | 7. Fuel lines, injector pump to injector nozzles (4) |
| 4. Fuel return manifold                   |  |

TA502323

Figure 7-15. Injection Fuel Lines.

**7-20. Fuel Stop Solenoid (Fig. 7-16)**

- a. Remove engine shroud panel.
- b. Remove the two screws fastening the solenoid to the bottom cylinder pan. Remove solenoid.
- c. Remove electrical lead to control.

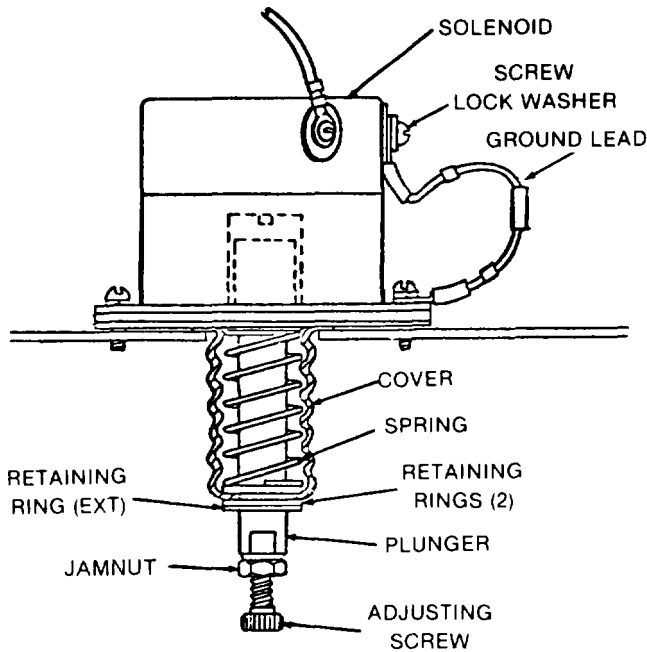

TA502290

**Figure 7-16. Removal of Fuel Stop Solenoid.**

**7-21. Engine Junction Box and Electrical Wiring**

Refer to paragraph 4-19 for removal

**7-22. Exhaust Manifold (Fig. 7-17)**

- a. Remove air shutter assembly (para 7-14).
- b. Remove exhaust pipe (para 4-77).
- c. Remove high temperature switch (para 7-17).
- d. Bend tabs (1, fig. 7-17) down, and remove eight capscrews (2) and washers (3) attaching exhaust manifold (4) to cylinder heads. Remove manifold and four gaskets (5).

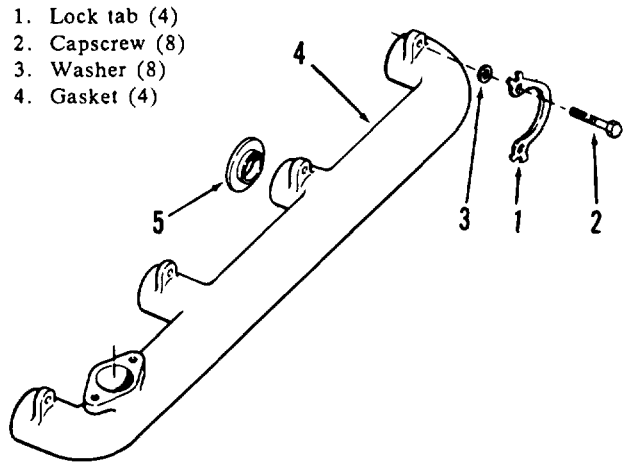

TA100089

**Figure 7-17. Exhaust Manifold.**

**7-23. Oil Filler Tube**

- a. Remove the fuel filter adapter (1, fig. 7-18) and fuel filters (2) as an assembly by removing three capscrews (3) and lockwashers (4). Lower assembly enough to expose the two filler tube mounting capscrews (1, fig. 7-19).
- b. Remove two capscrews (1) and lockwashers (2) that secure filler tube (3) to engine block.
- c. Remove filler tube (3) and gasket (4). Discard gasket.

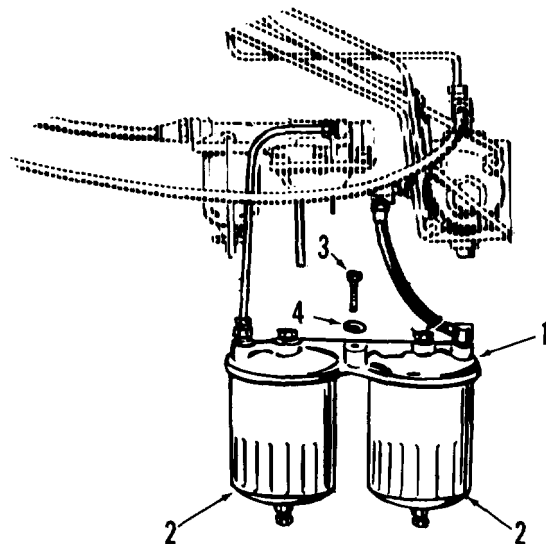

TA100090

**Figure 7-18. Removal of Fuel Filter Adapter**



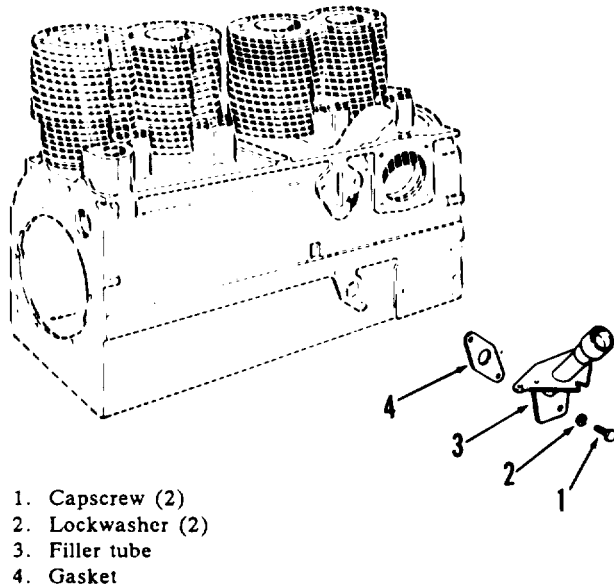

1. Capscrew (2)
2. Lockwasher (2)
3. Filler tube
4. Gasket

TA100091

Figure 7-19. Removal of Filter Tube.

**7-24. Oil Lines (Fig. 7-20)**

Disconnect oil line (9) at elbow (10) and restricted tee (14). Remove oil line (9).

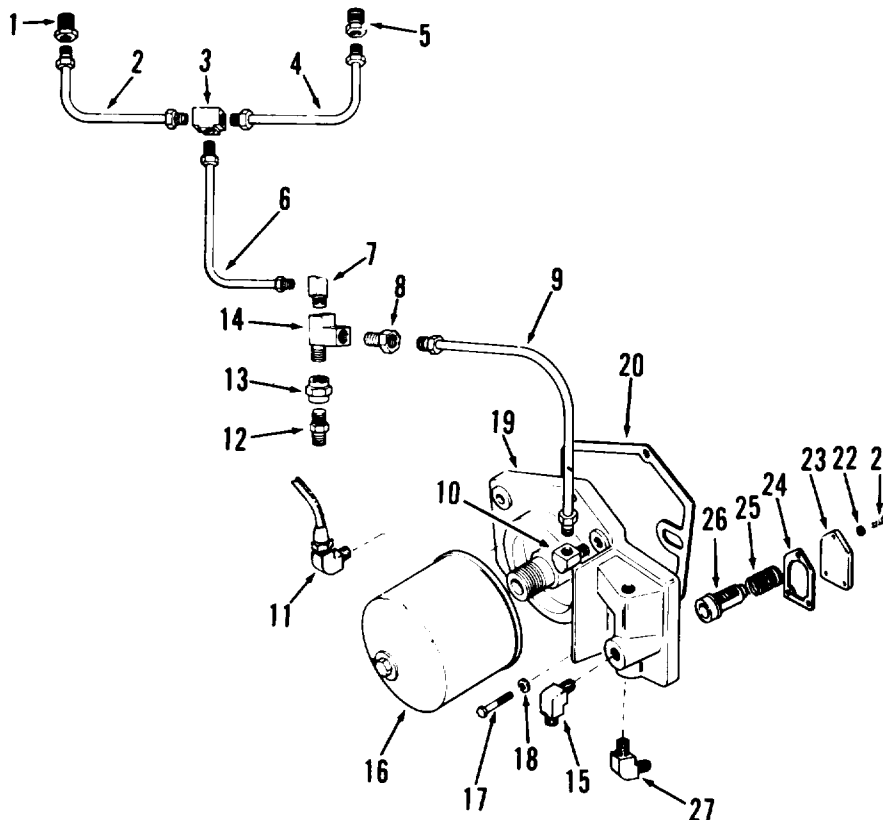

1. Adapter
2. Oil line
3. Restricted tee
4. Oil line
5. Adapter
6. Oil line
7. Elbow
8. Connector
9. Oil line
10. Elbow
11. Elbow (2)
12. Nipple
13. Coupling
14. Restricted tee
15. Elbow
16. Oil filter
17. Capscrew (3)
18. Lockwasher (3)
19. Oil filter adapter
20. Gasket
21. Capscrew(3)
22. Lockwasher (3)
23. Cover plate
24. Gasket
25. Spring
26. Thermostat
27. Elbow

TA100092

Figure 7-20. Oil Lines, Oil Filter Adapter and Oil Cooler Thermostat.

b. Disconnect oil line (2) from adapter (1) and restricted tee (3). Remove oil line (2).

c. Disconnect oil line (4) from adapter (5) and restricted tee (3). Remove oil line (4).

d. Disconnect oil line (6) at elbow (7), and remove oil line (6).

**7-25. Oil Filter Adapter (Fig. 7-20)**

a. Remove blower housing (para 7-14).

Disconnect oil cooler hoses from oil filter adapter (para 7-15).

c. Remove oil filter (para 4-72).

Disconnect oil lines from oil filter adapter (para 7-24).

e. Remove elbow (15, fig. 7-20).

f. Remove three screws (17) and washers (18), and remove oil filter adapter (19) and gasket (20). Discard gasket.

**7-26. Fuel Injection Pump (Fig. 7-21)**

**CAUTION**

**All fuel connections must be plugged or capped to prevent contamination.**

- a. Snap off governor linkage (1, fig. 7-14) from injection pump (2, fig. 7-14) and governor control arm (3, fig. 7-14), and remove linkage.
- b. Tag and disconnect high pressure lines at injector nozzles and at injection pump (fig. 7-15).
- c. Tag and disconnect inlet and fuel return lines from injection pump (para 4-73).
- d. Prior to removing the injection pump, position the number one piston on the compression stroke by placing the PC mark on the flywheel in line with timing mark on gear case cover (fig. 7-78).
- e. Remove the timing hole screw on the left side of pump mounting flange. Insert a 1/8-inch diameter brass wire in the timing index hole. If the piston is on the compression stroke, the wire will enter the index hole in the gear face. (Depth approximate 1 1/8-inch -GO, 7/8-inch—NO GO.) If not, rotate the flywheel one complete revolution and reinsert the wire.

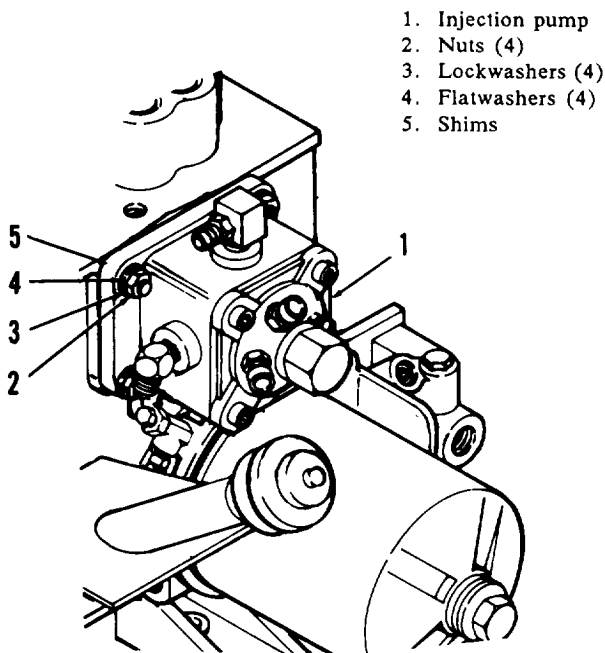

- 1. Injection pump
- 2. Nuts (4)
- 3. Lockwashers (4)
- 4. Flatwashers (4)
- 5. Shims

TA100093

**Figure 7-21. Fuel Injection Pump.**

f. Remove four hexagon nuts (2, fig. 7-21), lockwashers (3), and flatwashers (4), holding injection pump (1) to crankcase, and remove pump. Be careful to retain the shims (5) from between the crankcase and pump. The correct thickness of shims as stamped on the crankcase, above the injection pump, is important to proper pump operation; it provides the proper gear backlash.

g. When removing a pump for replacement, record the button thickness and port closing dimensions as stamped on the side of the pump mounting flange (fig. 7-76). These values are important in timing a new pump to the engine. If there is a standard button in the pump, it may not be stamped or it will have the number 11 stamped on the flange.

**7-27. Flywheel Assembly (Fig. 7-22)**

- a. Remove blower assembly (para 7-14).
- b. Remove screw (1) and washer (2) attaching flywheel to crankshaft.
- c. Install two screws in flywheel hub from puller(8) to remove flywheel (3), ring gear (5), and key (6).

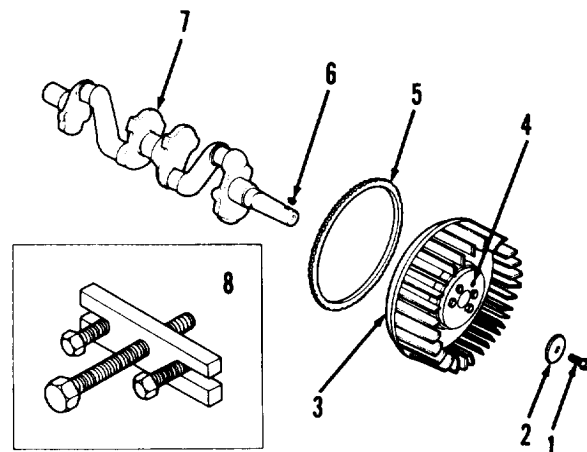

- 1. Screw
- 2. Washer
- 3. Flywheel
- 4. Hub
- 5. Ring gear
- 6. Key
- 7. Crankshaft
- 8. Puller (11671732)

TA100094

**Figure 7-22. Flywheel Assembly.**

**7-28. Fuel Injectors (Fig. 7-23)**

**CAUTION**

**All injector openings and nozzles must be capped when the injector is removed from the engine to prevent contamination.**

**NOTE**

**To remove injectors behind air intake manifold, remove air intake manifold (para 4-82).**

a Remove fuel lines (3 and 7, fig. 7-15) at fuel injectors.

b Remove screws (1, fig. 7-23), washers (2), and retaining flange (3).

c Remove fuel injector (4), gasket (5), adapter (6), gasket (7), and heat shield (8) as an assembly, and remove gasket (9). Separate fuel injector (4) from other parts by pressing it out.

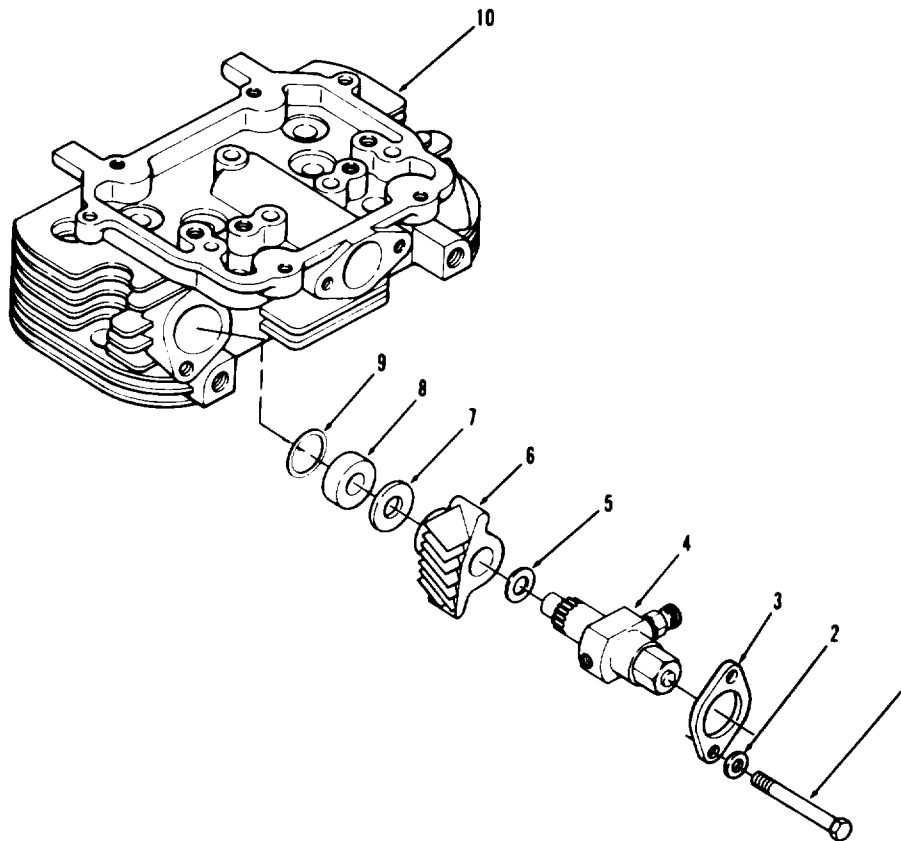

- 1. Screw (2)
- 2. Washer (2)
- 3. Retaining flange
- 4. Fuel injector
- 5. Gasket
- 6. Adapter
- 7. Gasket
- 8. Heat shield
- 9. Gasket
- 10. Cylinder head

**Figure 7-23. Fuel Injector Removal.**

TA100095

**7-29. Rocker Arm Covers (Fig. 7-24)**

a. Remove all necessary shrouding, and remove lifting bracket (para 7-14) to gain access to rocker arm covers.

b. Remove four screws (1, fig. 7-24) and lockwashers (2) attaching each rocker arm cover (3) to cylinder head (5), and remove cover carefully.

c. Remove and discard rocker arm cover gasket (4).

**7-30. Cylinder Head and Rocker Arms (Fig. 7-25)**

a. Remove all engine shrouding (para 7-14).

b. Remove exhaust manifold (para 7-22). Remove intake manifold (para 4-82).

Remove fuel injectors (para 7-28) and connecting oil lines (para 7-24) to head.

d. Remove glow plugs (para 4-21).

- 1. Screw (8)
- 2. Lockwasher (8)
- 3. Rocker arm cover (2)
- 4. Gasket (2)
- 5. Cylinder Head (2)

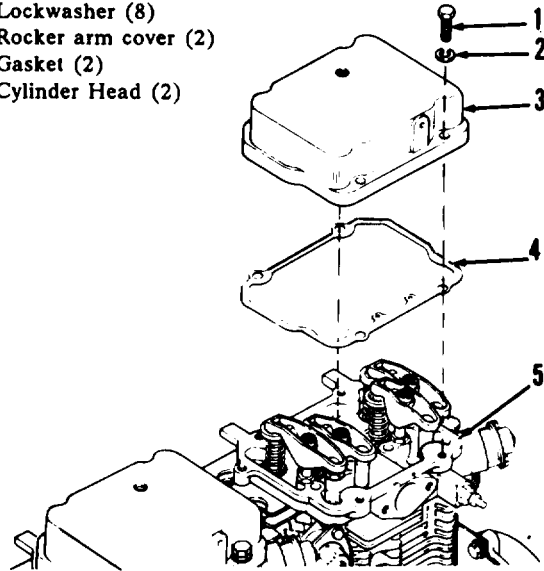
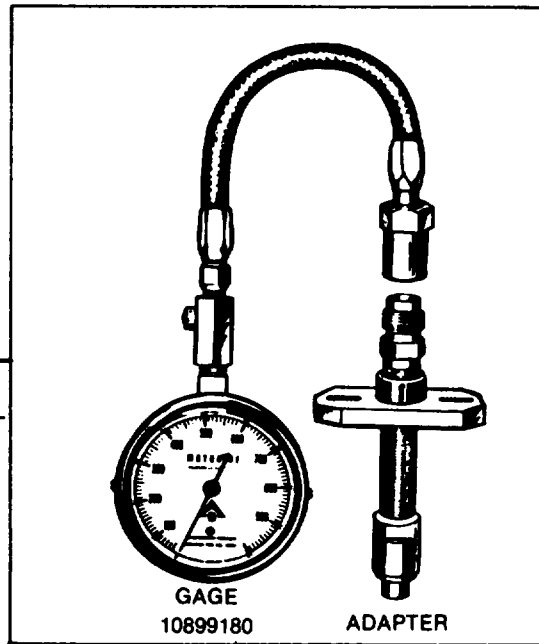
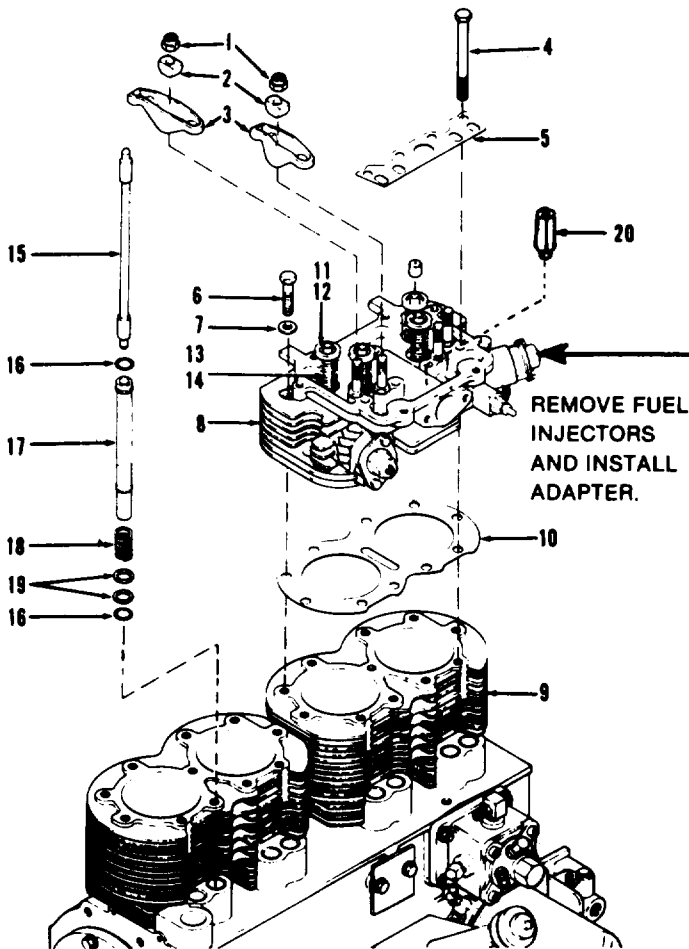

Figure 7-24. Rocker Arm Covers.



- 1. Nut (8)
- 2. Ball (8)
- 3. Rocker arm (8)
- 4. Screw (10)
- 5. Push rod guide (2)
- 6. Screw (12)
- 7. Washer (12)
- 8. Cylinder head (2)
- 9. Block
- 10. Gasket (2)
- 11. Spring retainer (16)
- 12. Valve spring retainer (8)
- 13. Spring (8)
- 14. Exhaust valve (4)
- 15. Push rod (8)
- 16. Push rod shield seal (16)
- 17. Shield (8)
- 18. Spring (8)
- 19. Washer (16)
- 20. Stand pipe vent (2)

Figure 7-25. Cylinder Head Removal,

TA100097

- e. Remove rocker arm cover and gasket (para 7-29).
- f. Remove the two baffles (34, fig. 7-9) by removing capscrew (32) and washer (33).
- g. Remove stand pipe vent (20, fig. 7-25).
- h. Remove recker arms by removing self-locking arm nuts (1, fig. 7-25) and recker arm balls (2) on each rocker arm (3). Lift recker arm (3) off.
- i. Remove five capscrews (4), push rod guide plate (5), six screws (6), and washers (7) holding each cylinder head (8) to cylinder block (9).
- j. Remove push rod (15) and remove cylinder heads. If heads stick, rap sharply with a soft hammer. Do not use a pry. Do not strike cooling fins.
- k. Remove push rod shields (17) and seals (16), spring (18), washers (19), and tappets (20).
- l. Remove cylinder head gaskets (10).

### 7-31. Piston and Connecting Rod

#### a. *General (Fig. 7-26).*

(1) Each piston (7) is fitted with three compression rings and an oil control ring (4).

(2) Full floating piston pins (6) connect the piston to the connecting rod (12). The pins are held in place with a retaining ring (5) at each end.

(3) The lower end of each connecting rod contains half-shell, precision bearings (11), and the upper end contains reamed bushings (13).

#### b. *Removal (Fig. 7-27).*

#### NOTE

- **The connecting rod and cap are stamped for installation in the proper cylinder. When removing piston assemblies, check the marking so each piston can be installed in the proper cylinder.**
- **When using some maintenance stands, the engine starter and air shutter assembly**

#### **may have to be removed before attaching engine.**

(1) Remove engine from engine mounting frame (para 5-20) and attach to an engine maintenance stand, if not done previously.

(2) Drain crankcase oil (para 4-71).

(3) Remove cylinder heads (para 7-30).

#### NOTE

**Do not set the cylinder assembly upright until after removal of the oil pump pick-up cup assembly, camshaft, and valve tappets described in the following paragraphs.**

(4) Turn cylinder block and oil base on its side.

#### CAUTION

**Do not attempt to pry the oil base free of the cylinder block assembly. If necessary, use a soft mallet to separate the oil base.**

(5) Remove ten capscrews (3, fig. 7-27) and lockwashers (4) and remove the oil base (1) from cylinder block (38).

(6) Remove screws (4, fig. 7-32), lockwasher (3), and bracket (2), and remove oil cup assembly (1).

(7) Remove ridge from cylinder bore with a ridge reamer before removing piston.

(8) Remove bolts (5, fig. 7-27), cap (7), and two bearings (6) from each connecting rod (8). Push piston assembly (9) upward through top of cylinder bore with a soft wooden tool to prevent rod bearing damage. If piston assembly cannot be removed, turn crankshaft to align connecting rod with the crankshaft.

(9) Loosely install cap (7) and bearings (6) on the corresponding removed piston assembly to maintain proper grouping.

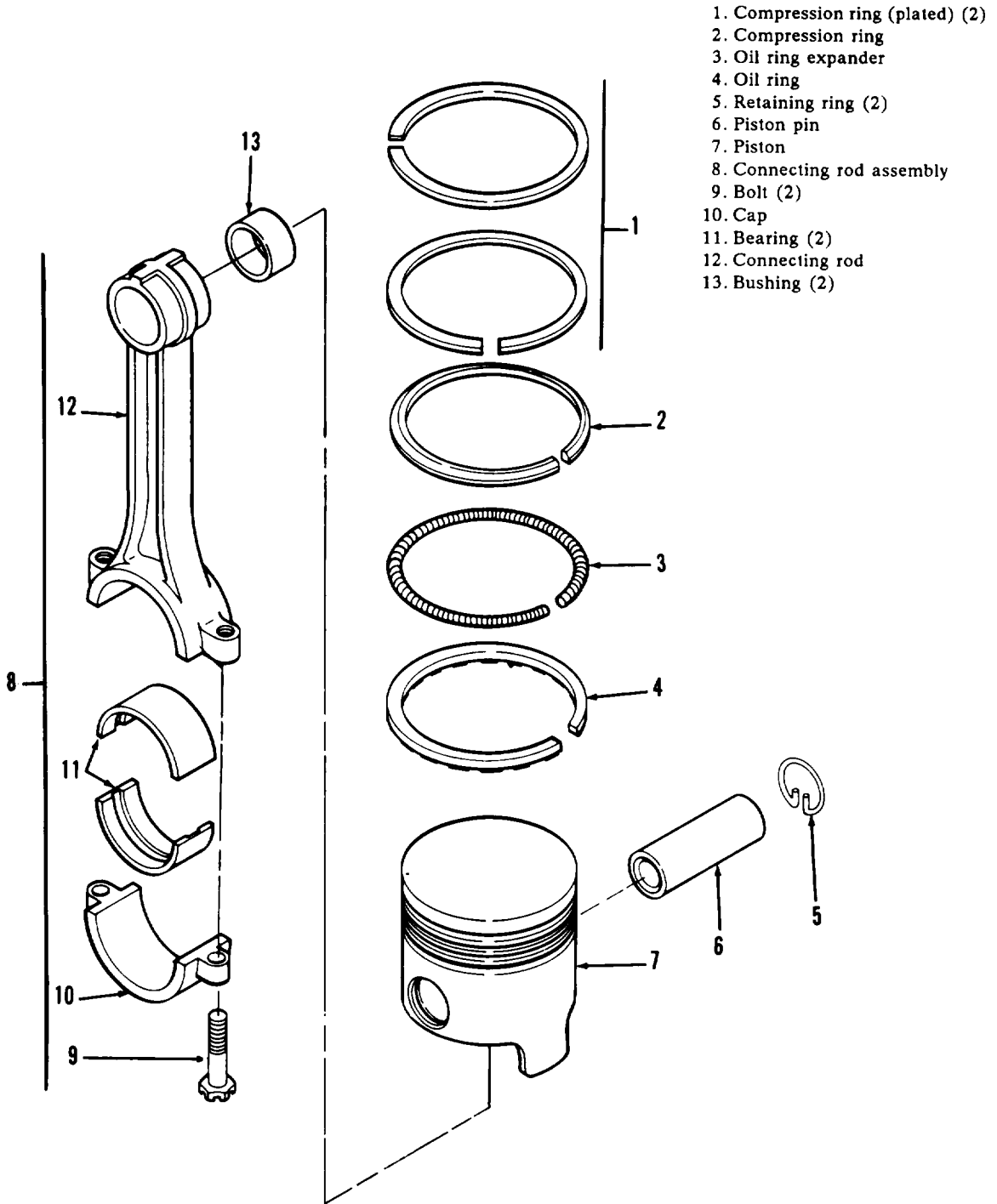
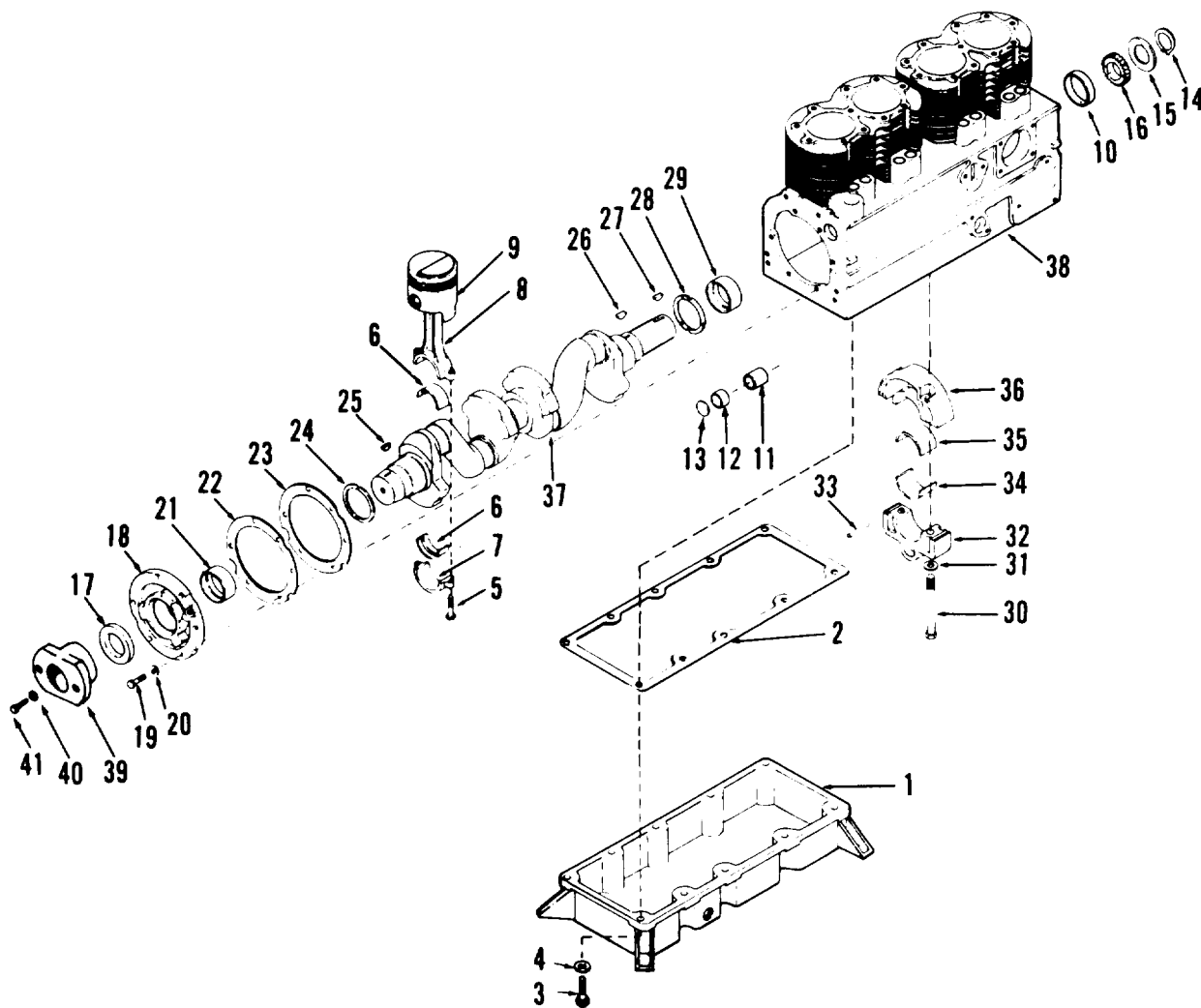

Figure 7-26. Piston Connecting Rod.

TA100098



- |                             |                            |                                   |
|-----------------------------|----------------------------|-----------------------------------|
| 1. Oil base                 | 15. Crankshaft washer      | 29. Crankshaft end bearing        |
| 2. Gasket                   | 16. Crankshaft gear        | 30. Bolt (2)                      |
| 3. Screw (10)               | 17. Rear crankcase seal    | 31. Washer (2)                    |
| 4. Lockwasher (10)          | 18. Rear bearing plate     | 32. Bottom center bearing housing |
| 5. Bolt (8)                 | 19. Screw (6)              | 33. Dowel                         |
| 6. Bearing (8)              | 20. Flatwasher (6)         | 34. Lower bearing                 |
| 7. Cap (4)                  | 21. Crankshaft end bearing | 35. Upper bearing                 |
| 8. Connecting rod (4)       | 22. Gasket                 | 36. Center bearing housing        |
| 9. Piston assembly (4)      | 23. Shim                   | 37. Crankshaft                    |
| 10. Front camshaft bearing  | 24. Thrust washer          | 38. Cylinder block                |
| 11. Center camshaft bearing | 25. Key                    | 39. Pump coupling flange          |
| 12. Rear camshaft bearing   | 26. Key                    | 40. Washer                        |
| 13. Plug                    | 27. Key                    | 41. Screw                         |
| 14. Retaining ring          | 28. Thrust washer          |                                   |

Figure 7-27. Crankshaft, Pistons, and Connecting Rod.

TA100099

**7-32. Gear Cover Assembly**

- a. Remove blower housing (para 7-14) if removal is done with engine attached to vehicle.
- b. Remove governor arm (3, fig. 7-14) by loosening screw (3, fig. 7-28).
- c. Remove flywheel assembly (para 7-27).
- d. Remove four screws (1, fig. 7-31), lockwashers (2), screw (3), and lockwasher (4) holding gear cover(5) to crankcase. Remove two screws (31), lockwashers (30), cover (29), and gasket (28). Tape crankshaft keyway to prevent damage to seal (11, fig. 7-28). To loosen gear

cover, tap it with a soft hammer. Remove gasket (6, fig. 7-31).

**7-33. Governor Cup (Figs. 7-29 and 7-30)**

- a. Remove retaining ring (fig. 7-30) from camshaft center pin.

**NOTE**

**Be sure to catch the ten flyballs that will fall out when cup is removed.**

- b. Slide governor cup off camshaft center pin.

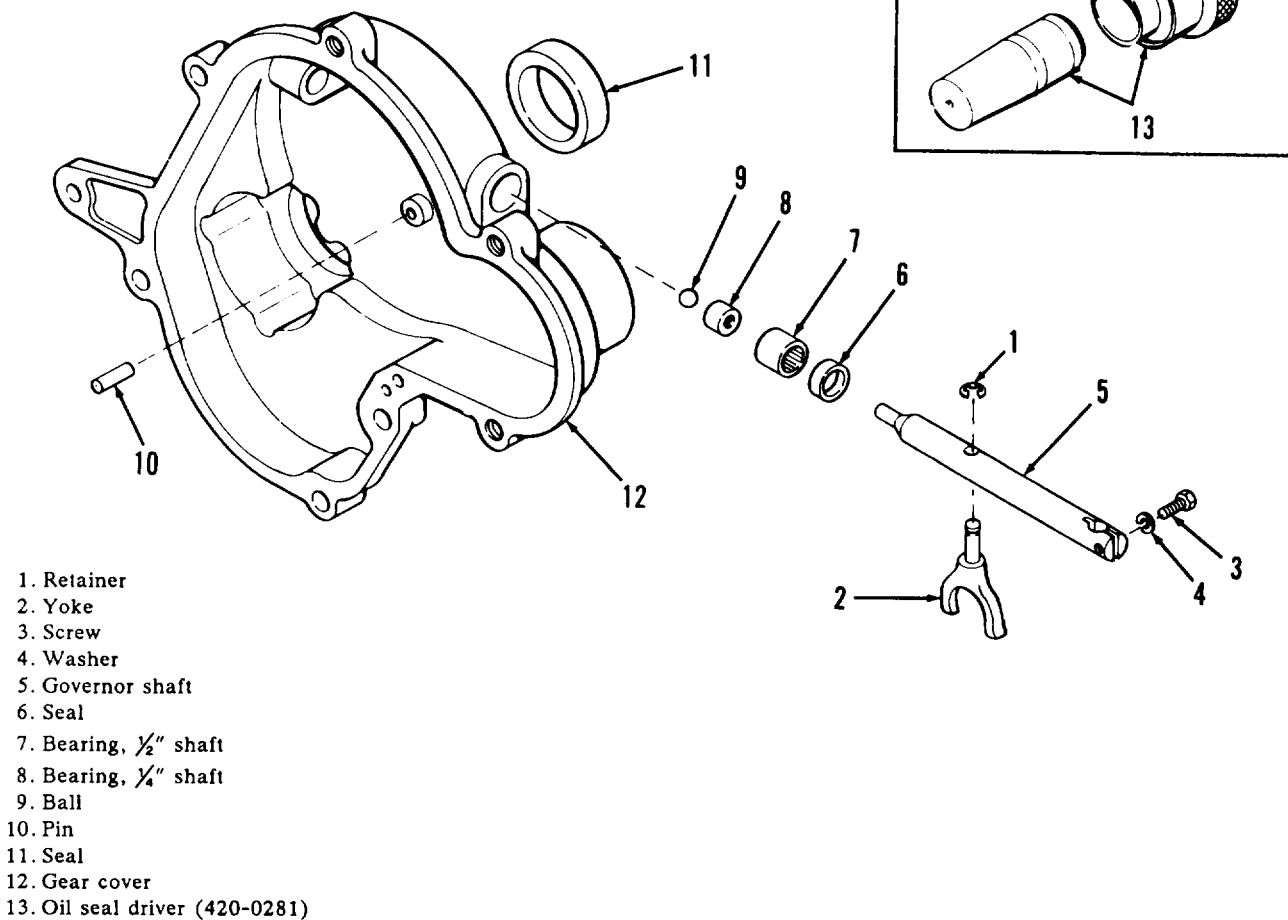

*Figure 7-28. Gear Cover Components.*

TA100100



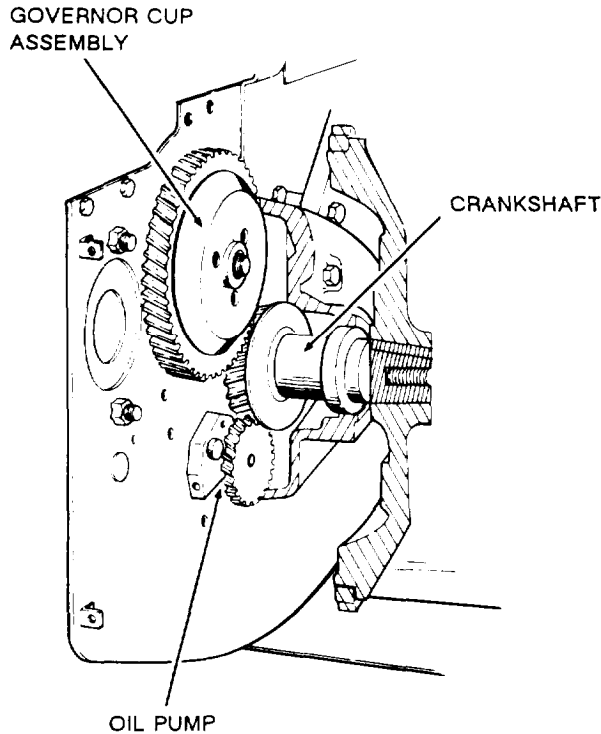

TA100101

Figure 7-29. Location of Governor Cup.

WHEN GOVERNOR IS PROPERLY ASSEMBLED, DISTANCE FROM CENTER PIN TO GEAR FACE WILL BE 25/32"

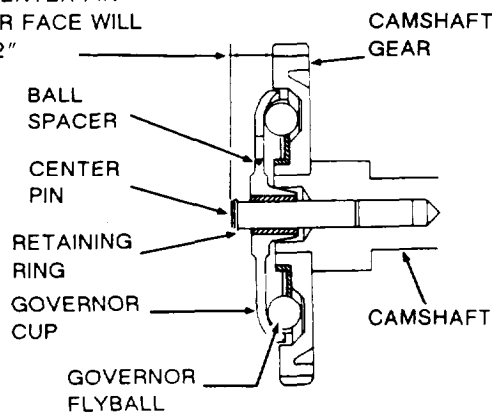

TA100102

Figure 7-30. Governor Cup Assembly.

### 7-34. Camshaft and Tappets

- a. Remove engine (para 5-20). Install engine in an engine maintenance stand.
- b. Remove blower housing (para 7-14).
- c. Remove rocker arm covers (para 7-29).
- d. Remove gear cover assembly (para 7-32).
- e. Remove fuel injection pump (para 7-26).
- f. Remove crankshaft gear retaining washer (8, fig. 7-31) by removing retaining ring(7) on the crankshaft.
- g. Remove rocker arms and push rods (para 7-30).
- h. Remove oil base (para 7-31).

#### CAUTION

**When removing camshaft be careful not to damage bearings (24, 25, and 26, fig. 7-31).**

- i. Lay engine on side to avoid dropping tappets (27) and remove camshaft assembly (14) as a group. If necessary, pry it out with a screwdriver between camshaft gear and crankcase. Remove retaining ring (15) and press gear (16) off camshaft.
- j. Remove the valve tappets (27). These can be removed only from bottom of crankcase.
- k. Refer to paragraph 7-36j and 7-36k, and remove crankshaft gear.
- l. Camshaft Bearings. The camshaft bearings (24, 25, and 26, fig 7-31) should be replaced if clearance to camshaft is greater than specified in table 7-2, or if bearings show cracks, breaks, burrs, excessive wear, or other defects. The camshaft-to-bearing clearance should be 0.0012- to 0.0037-inch. To check rear bearing (24), remove expansion plug (23) at rear of crankcase.

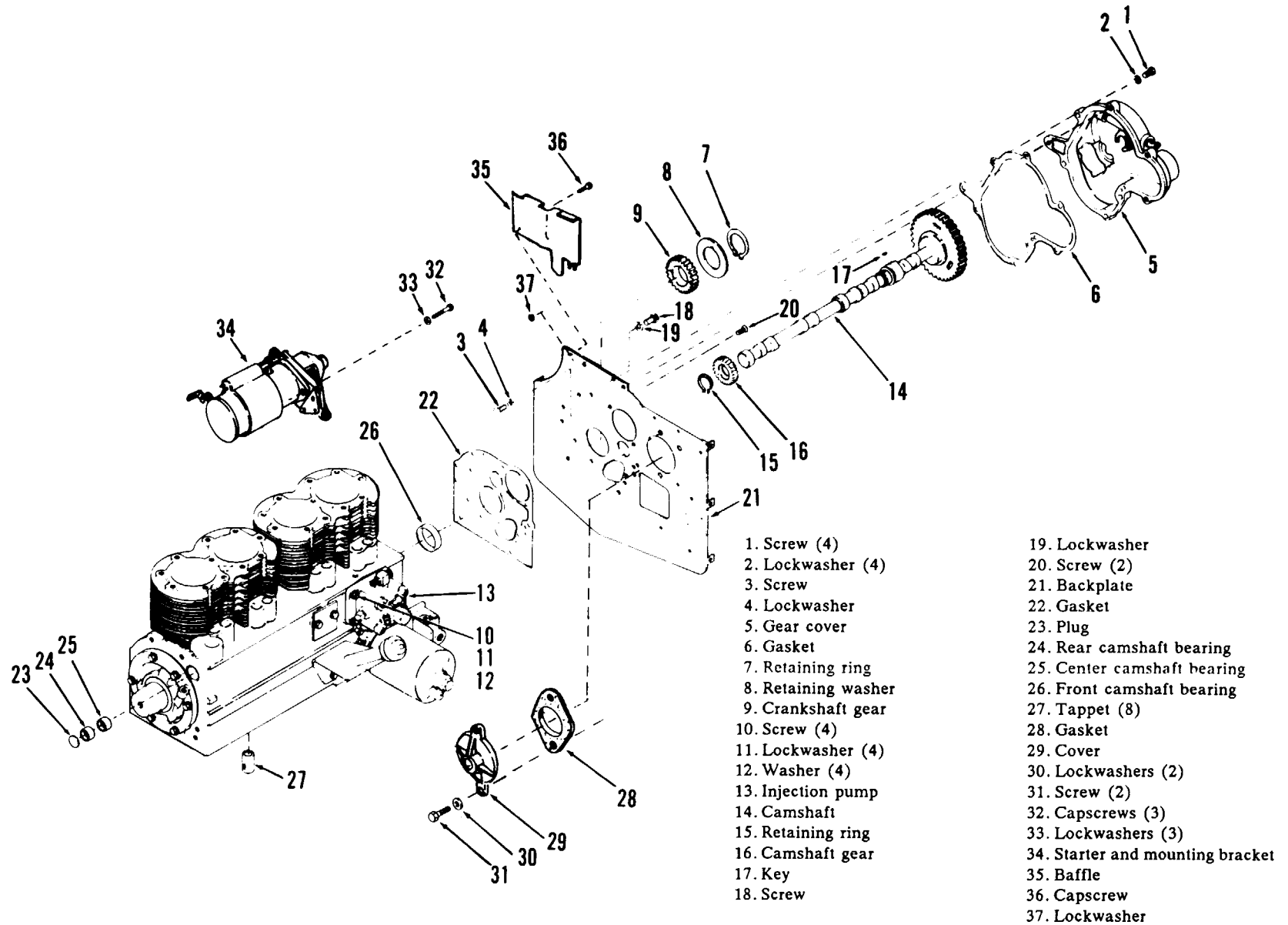

Figure 7-31. Partial Internal Engine Assembly.

TA100103

**7-35. Oil Pump**

- a. Remove gear cover assembly TM (para 7-32).
- b. Remove oil base assembly and oil cup assembly (para 7-31).
- c. Remove crankshaft gear lock ring (5, fig. 7-32) and retaining washer (6). At this time crankshaft gear (7) should be inspected for signs of wear.
- d. Hold the oil pump (10) while removing attaching screws (8) and lockwashers (9). Remove oil pump (10).

**7-36. Crankshaft and Main Bearings (Fig. 7-27)**

- a. Remove engine (para 5-20). Install engine in an engine maintenance stand.
- b. Remove blower housing (para 7-14),
- c. Remove oil cooler and lines (para 7-15).
- d. Remove oil filter adapter (para 7-25).
- e. Remove flywheel (para 7-27).

- f. Remove gear cover assembly (para 7-32).
- g. Remove cylinder heads (para 7-30),
- h. Remove oil base (para 7-31).
- i. Remove oil pump cup assembly (para 7-35).
- j. Remove retaining ring (14, fig. 7-27) and retaining washer (15) in front of crankshaft gear (16).
- k. Pull off crankshaft gear. It has two ¼-20 NC tapped holes for attaching a gear pulling ring (fig. 7-33). Use care not to damage teeth if gear is to be re-used. Remove woodruff keys (26 and 27, fig. 7-27).
- l. Remove three capscrews (32, fig. 7-31), lockwashers (37), and starter and mounting bracket (34).
- m. Remove capscrew (18), lockwasher (19), and baffle (35).
- n. Remove capscrew (36), lockwasher (37), two flat head screws (20), and backplate (21). Remove connecting rod and piston assemblies (para 7-31).

- |                     |                   |
|---------------------|-------------------|
| 1. Oil cup assembly | 6. Washer         |
| 2. Bracket          | 7. Gear           |
| 3. Lockwasher       | 8. Screw (2)      |
| 4. Screw            | 9. Lockwasher (2) |
| 5. Lock ring        | 10. Oil pump      |

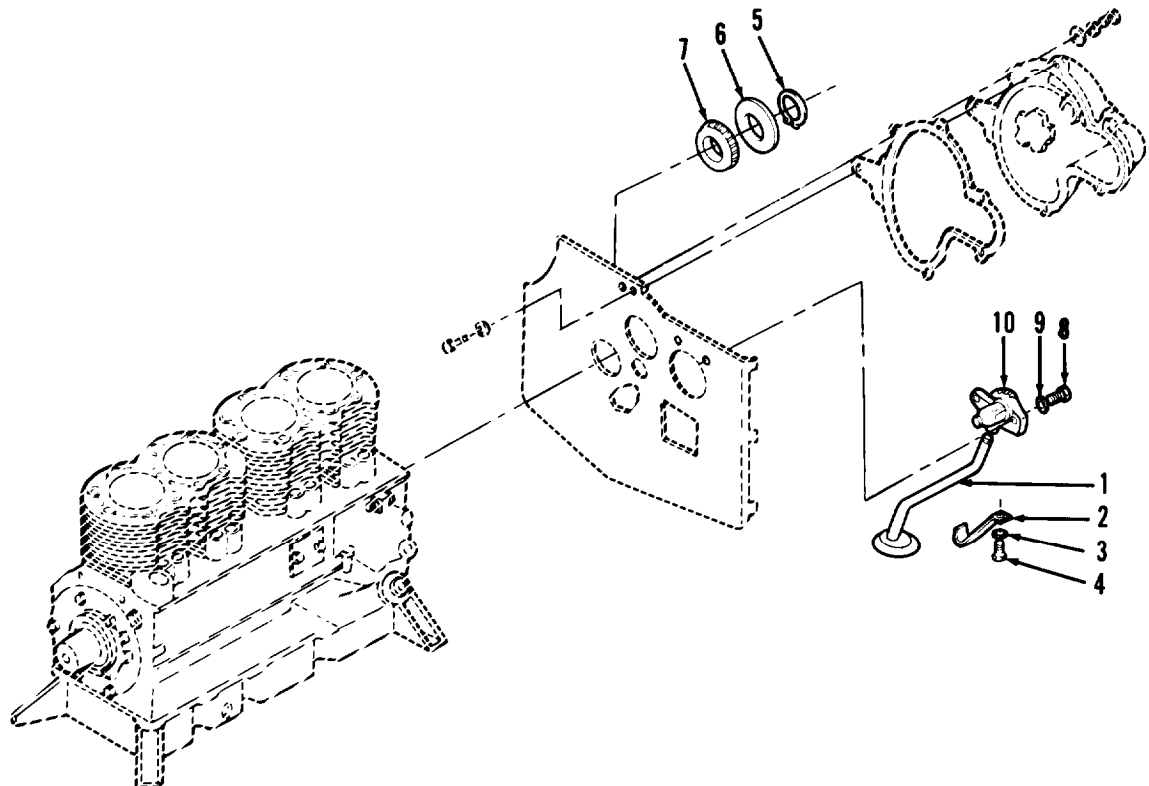

**Figure 7-32. Oil Pump Removal.**

TA502324

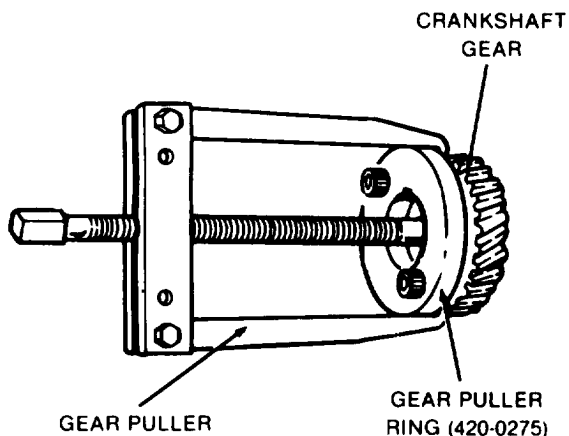

TA100105

Figure 7-33. Crankshaft Gear Removal.

*o.* Remove bolt (41, fig. 7-27) and washer (40) from end of crankshaft. Using a puller, remove pump coupling (39). Remove woodruff key (25).

*p.* Remove rear bearing plate (18) from crankcase. Remove gasket (22) and shims (23).

*q.* Remove two bolts (30), washers (31), bottom center main bearing housing (32), and center bearing (34). Rotate crankshaft and remove upper center bearing housing (36) and center bearing (35). Remove crankshaft (37) through rear opening in crankcase.

### 7-37. Instruction Procedures

*a.* The following paragraphs contain step-by-step instructions necessary to reassemble the engine following maintenance procedures.

*b.* Prior to undertaking engine reassembly, certain major components such as the crankshaft, camshaft and governor, fuel pumps, and cylinder head should be inspected and repaired as described in Section III, Repair Instructions.

*c.* During reassembly of the engine, the work area should be as clean as possible to reduce engine contamination which can cause engine failure.

*d.* Use only clean, lint free cloth (item 24, Appendix E) for wiping engine parts. Oil and diesel fuel used during the reassembly process must be clean. Handle all parts carefully, especially bearings and machined surfaces.

### CAUTION

**Ensure that all components are coated with the proper grade of oil as they are assembled.**

**Failure to follow this caution may result in damage to engine components.**

*e.* During reassembly of internal engine components, coat all components heavily with oil of the same grade to be used in the crankcase. During the first few moments of operation, the engine will depend upon this lubrication. Refer to Section I Chapter 3 for proper lubricants.

### 7-38. Crankshaft and Main Bearing Blocks (fig. 7-27)

#### NOTE

**After each installation step, check crankshaft to be sure it is not frozen in place.**

*a.* Heat cylinder block (38, fig. 7-27) and bearing plate (18) at 325°F in oven for 30 minutes, then press front and rear main bearings (21) into place, aligning bearing housing oil holes (fig. 7-34).

*b.* Install thrust washers (24, fig. 7-27) over end of crankshaft.

*c.* Oil the bearings surfaces and install crankshaft (37, fig. 7-27) from rear of crankcase through rear bearing plate hole. Align slots in front thrust washer (24) with locating pins (fig. 7-34).

*d.* Install bearing (34, fig. 7-27) into lower center main bearing housing (32). Install bearing (35) into upper center bearing housing (36). Set the upper half of the center main housing (36) on the crankshaft (37) and rotate it into place. Be sure it is installed with the side marked front toward the crankshaft gear. Set the two positioning dowels (33) on the upper bearing mount. Install the center main bearing housing (32) and tighten the center main bolts (30) per specifications in table 7-3.

*e.* Place gasket (22) on each side of shim (23) and place on rear bearing plate (18).

#### NOTE

**Before tightening capscrews(19) ensure that thrust washers (24) are in position over locating pins.**

*f.* Before installing bearing plate, tape keyway and sharp edges on crankshaft to protect the oil seal during installation. Place rear thrust washer (24) over locating pins on rear bearing plate (18). Mount and secure rear bearing plate (18) with six capscrews (19) and flatwashers (20).

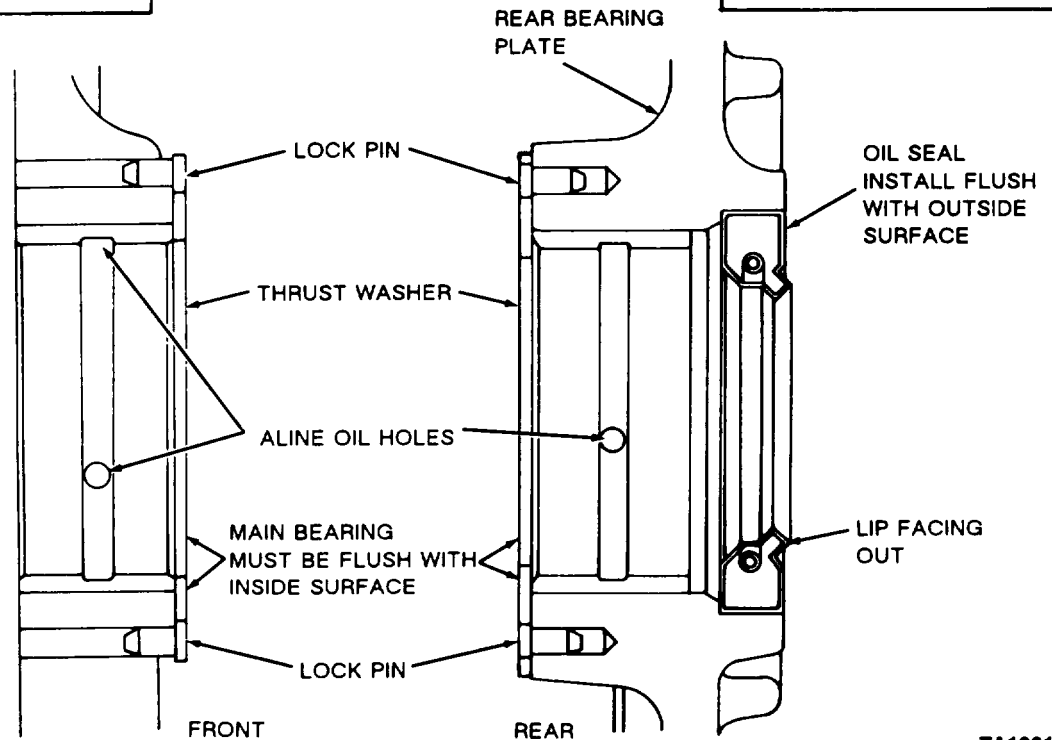
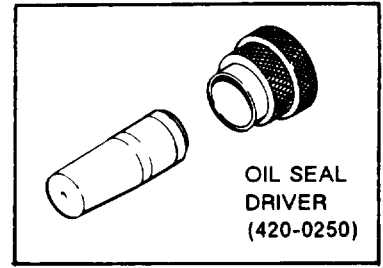
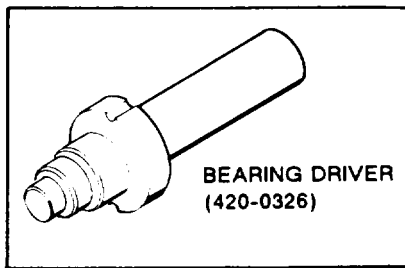

TA100106

Figure 7-34. Crankshaft Bearing Installation.

*g.* Check crankshaft end play (fig. 7-35). Use enough rear bearing plate shims (23, fig. 7-27) to provide 0.010- to 0.015-inch end play. If more than 0.010-inch total thickness is required, use a steel shim of proper thickness and a 0.005-inch thick gasket on each side of shim. This avoids excessive gasket compression and maintains bolt torque.

*h.* Install new gasket (22, fig. 7-31) and backplate (21). Secure with cap screw (36), lockwasher (37), and two flat head screws (20).

*i.* Install baffle (35) onto backplate (21). Secure with cap screw (18) and lockwasher (19).

*j.* Install starter and mounting bracket (34) onto backplate (21) with three cap screws (32) and lockwashers (33).

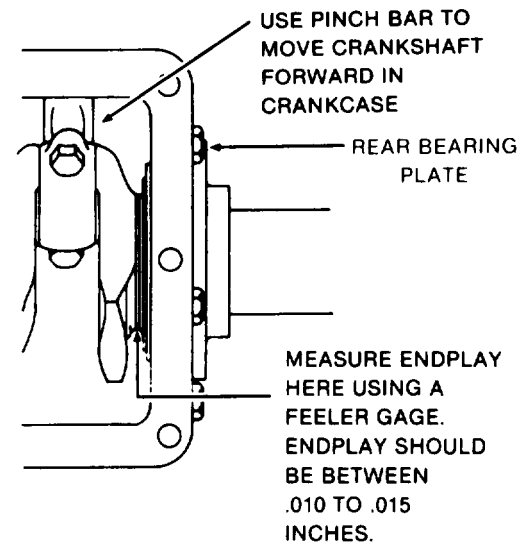

TA100107

Figure 7-35. Crankshaft End Play Measurement.

**NOTE**

DO NOT install crankshaft washer (15) or retaining ring (14) if camshaft has to be installed in crankcase. Camshaft gear will not clear the retaining washer.

Install keys (26 and 27, fig. 7-27) on crankshaft (37). Use fabricated tool (table 5-2) to drive gear (16) into place, with beveled side facing engine crankcase. Fully seat gear. Install crankshaft washer (15) and retaining ring (14) only if camshaft has not been removed.

l. Install key (25) on crankshaft. Drive pump coupling flange (39) onto end of crankshaft. Install washer (40) and capscrew (41).

m. Install rod and piston assemblies (para 7-43).

n. Install oil pump cup assembly (para 7-39).

o. Install oil base (para 7-43).

p. Install gear cover assembly (para 7-42).

q. Install flywheel (para 7-47).

r. Install cylinder heads (para 7-44).

s. Install blower housing (para 7-60).

7-39. Oil Pump (Fig. 7-32)

a. Install gear (7, fig. 7-32), retaining washer (6), and lock ring (5).

b. Fill pump intake and outlet with oil to ensure that it is primed.

**CAUTION**

**Failure to allow clearance can damage oil pump.**

c. Mount oil pump (10) on engine using screws (8) and lockwashers (9). Allow pump drive gear to crankshaft gear clearance. Clearance must be 0.005-inch backlash.

d. Install oil cup assembly (1) into oil pump (10).

Install bracket (2) on center main bearing housing and secure with lockwasher (3) and screw (4).

f. Install oil base (para 7-43).

g. Install gear cover (para 7-42).

**7-40. Camshaft Assembly and Tappets (Fig. 7-31)**

**NOTE**

**Expansion plug must not protrude from rear face of crankcase.**

a. Press new camshaft bearings into place using bearing driver 420-0326 (table 5-1). See figure 7-36 for proper placement. Press bearing flush with bottom of expansion plug recess. Press front bearing flush with crankcase front surface with oil passages aligned. Do not attempt to ream bearings; they are a precision type. After rear bearing is installed, insert a new expansion plug in recess, using sealing compound, and expand it into place with sharp blows at its center.

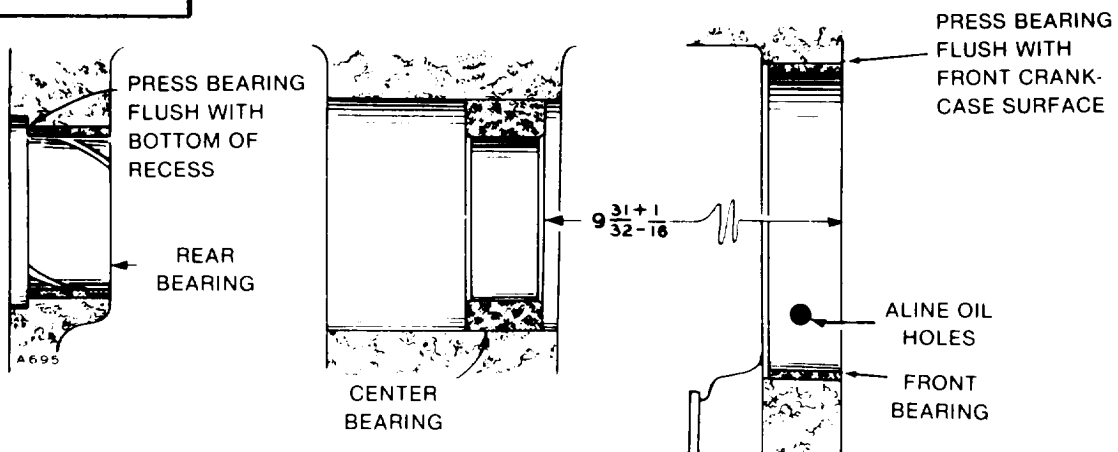
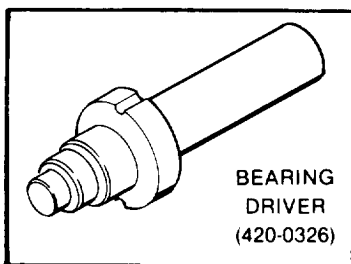

Figure 7-36. Camshaft Bearing Installation.

TA100108

b. With engine laid on its side, install tappets (27, fig. 7-31).

c. Install key (17, fig. 7-31) on camshaft (14). Press on gear (16) and install retaining ring (15).

d. Install camshaft assembly (14) in engine, and ensure that tappets (27) are in place. Aline timing marks on camshaft gear and crankshaft gear (fig. 7-37). Install retaining washer (8) and retaining ring (7). Use a pinch bar and pry up on crankcase gear (fig. 7-28). Using a feeler gage, measure the gap between the camshaft gear and crankshaft retainer washer. Gap should be .007- to .039-inches.

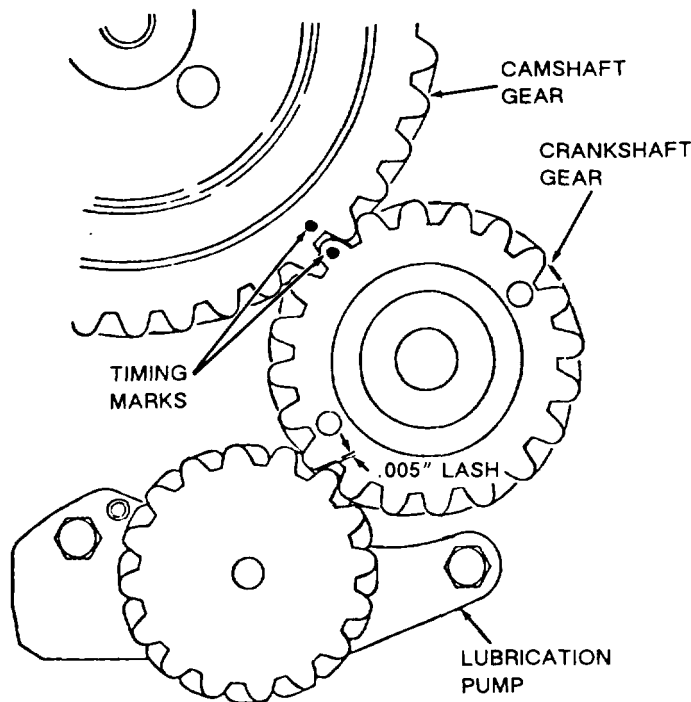

TA502325

**Figure 7-37. Crankshaft and Camshaft Gear Timing Marks.**

e. Turn engine with oil base down and install push rods (para 7-43).

f. Install oil base (para 7-43).

g. Install crankshaft gear retaining washer (8, fig. 7-31) and retaining ring (7) on the crankshaft.

h. Install rocker arms (para 7-44).

i. Install fuel injection pump (para 7-48).

j. Install gear cover assembly (para 7-42).

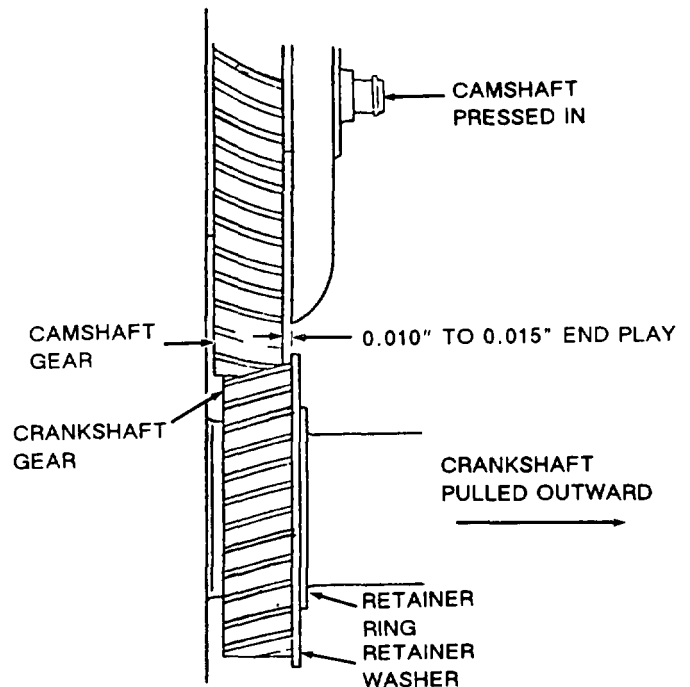

TA502326

**Figure 7-38. Timing Gear End Play.**

k. Install recker arm covers (para 7-45).

l. Install blower housing (para 7-60).

m. Install engine (para 5-20).

#### 7-41. Governor Cup (Fig. 7-30)

a. Fill flyball recesses with grease (item 16, Appendix E) and install flyballs.

b. Position governor cup on shaft and install retaining ring.

#### 7-42. Gear Cover Assembly (fig. 7-28)

a. Pack the cavity between the two oil seal lips (6, fig. 7-28) with grease (item 16, Appendix E).

b. Tape keyway and sharp edges on crankshaft to protect the oil seal during installation.

c. Mount gear cover (5, fig. 7-31) on engine using new gasket(6), screws (1 and 3), and lockwashers (2 and 4). Tighten mounting screws to specified torque (table 7-3). Before tightening screws, ensure that stop pin is in governor cup hole.

d. Install cover (29, fig. 7-31) and gasket (28) with two capscrews (31) and lockwashers (30).

e. Install flywheel assembly (para 7-47).

f. Replace governor arm (3, fig. 7-14) by tightening screw (3, fig. 7-28).

g. Install blower housing (para 7-60).

### 7-43. Pistons and Connecting Rods (Fig. 7-27)

a. Hone cylinder walls. Clean and oil the cylinder walls. Install each piston in proper cylinder using a suitable piston ring compressor. Each piston assembly should be installed with notch on piston toward front of engine.

b. Position each connecting rod on crankshaft, oil the journal, and install rod cap with bearing half. When installing rod cap, position so raised witness mark on the forging matches the mark on connecting rod (figs. 7-27 and 7-39). Piston witness mark should face front, and rod witness marks toward camshaft side of engine.

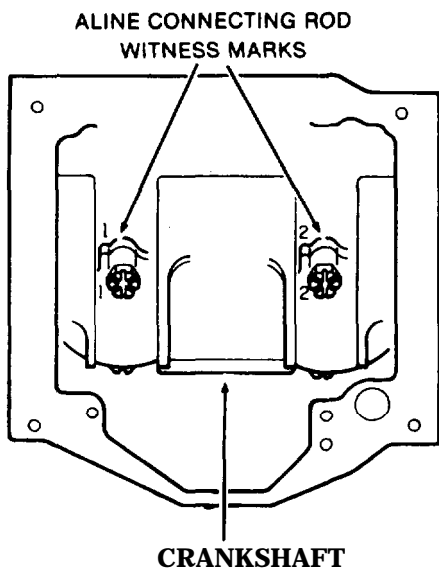

TA100111

Figure 7-39. Connecting Rod Installation.

c. Tighten capscrews to specified torque (table 7-3).

#### NOTE

**After installation of new connecting rod or main bearings, clearances should be checked using plastic gage.**

d. turn engine over by hand to see that all bearings are free.

e. Install oil base (1, fig. 7-27) with a new gasket (2) using ten screws (3) and lockwashers (4). Tighten to specified torque (table 7-3).

f. Install cylinder heads (para 7-44).

### 7-44. Cylinder Head and Rocker Arms (Fig. 7-25)

a. Place head assemblies (8, fig. 7-25) and gaskets (10) on cylinder block (9). Install springs (18), washers (19), and seals (16) on push rod shields (17), and install assembled push rod shields in cylinder block. Lift backside of cylinder head in place. Use an anti-seize compound (item 5, Appendix E) on head bolt threads, and thread bolts (4 and 6) and washers (7) into cylinder block (9). Do not tighten head bolts at this time.

#### NOTE

**Installing exhaust manifold now aligns all four exhaust ports with exhaust manifold before the heads are torqued down.**

b. Install exhaust manifold (para 7-52). Tighten mounting screws to 13–15 lb.-ft. (table 7-3). Now tighten head bolts to 44-46 lb.-ft. (table 7-3) following sequence in figure 7-40.

c. Install the intake manifold (para 4-82).

d. Install eight push rods (15, fig. 7-25), rocker arms (3), rocker arm balls (2), and rocker arm nuts (1).

e. Set valve clearance (para 7-89).

f. Replace rocker arm cover and gasket (para 7-45).

g. Install fuel injectors (para 7-46).

h. Install the two baffles (34, fig. 7-9), and secure with capscrew (32) and washer (33).

i. Install engine shrouding (para 7-60).

### 7-45. Rocker Arm Covers (Fig. 7-24)

a. Place gasket (4, fig. 7-24) in position on each cylinder head.

b. Install each rocker arm cover (3) to cylinder head and secure with four screws (1) and lockwashers (2). Tighten screws to 8-10 lb.-ft.

c. Replace shrouding previously removed (para 7-60).

### 7-46. Fuel Injectors (Fig. 7-23)

a. Ensure that old gasket material has been removed from injector (4, fig. 7-23).

b. Assemble new nozzle gasket (5) adapter (6), gasket (7), and heat shield (8) on injector (4) and press together.

c. Install gasket (9) and injector and assembled parts into cylinder head (10).



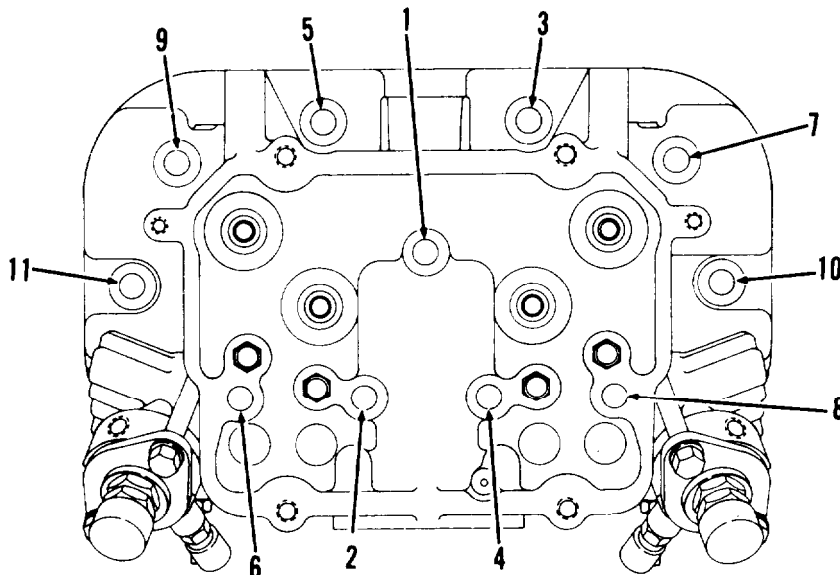

TA100112

Figure 7-40. Cylinder Head Bolt Tightening Sequence.

d. Install retaining flange (3), and tighten down with screws (1) and washers (2).

e. Reconnect fuel lines (para 7-55).

**7-47. Flywheel Assembly (Fig. 7-22)**

a. Mount ring gear (5), flywheel (3), and hub (4) to crankshaft using screw (1) and washer (2).

b. Install blower housing (para 7-60).

**7-48. Fuel Injection Pump (Fig. 7-21 )**

a. Tune engine flywheel to the port closing mark (PC) on the front cylinder (closest to blower wheel) compression stroke (fig. 7-78).

b. If new injection pump is being installed, remove timing hole screw located on pump mounting flange (fig. 7-41). Insert a 1/8-inch diameter wire into the hole.

c. Rotate pump face gear until wire slips into place, locking the gear in position.

d. Mount pump on crankcase (fig. 7-21), ensuring that shims (5) are in place, and secure in position using four hexagon nuts (2), flatwashers (4), and lockwashers (3). If O-ring seal between pump and crankcase is worn, cracked, or otherwise defective, replace it.

e. Remove wire. Install timing hole screw and copper gasket.

f. Time injection pump (para 7-86).

g. Connect flexible fuel inlet line to pump inlet. Connect fuel return line.

h. Connect each fuel outlet line to the proper pump outlet (para 4-73 and 7-55)

i. Connect governor linkage to governor arm.

j. Start and run engine. Adjust governor linkage if required (para 4-76).

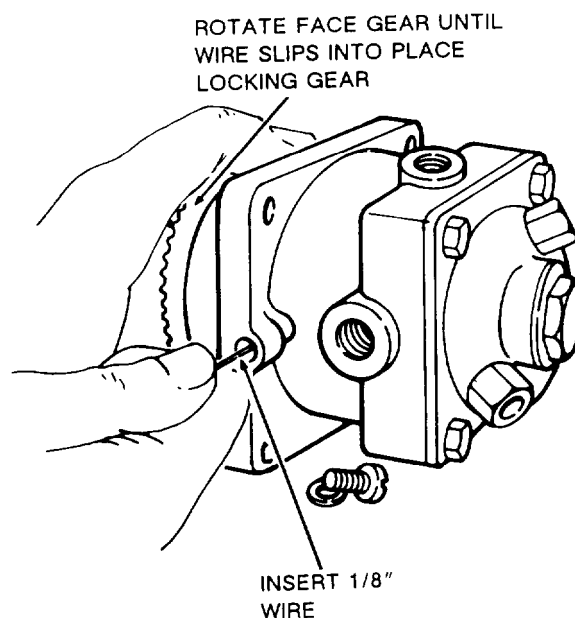

TA100113

Figure 7-41. Injection Pump Installation.

**7-49. Oil Filter Adapter (Fig. 7-20)**

a. Clean all gasket material from oil filter adapter (19, fig. 7-20) and cylinderblock. Attach oil filter adapter (19) and new gasket (20) to cylinder block with three capscrews (17) and lockwashers (18). Tighten capscrews to 45-50 lb.-ft.

b. Attach all oil lines to oil filter adapter (para 7-50).

c. Install oil filter (para 4-72).

d. Install elbow (15). Tighten elbow securely to position 90° right of top center.

e. Attach oil cooler hoses 10 oil filter adapter (para 7-59).

f. Replace blower housing (para 7-60).

**7-50. Oil Lines (Fig. 7-20)**

a. Connect oil line (6, fig. 7-20) to elbow (7).

b. Connect oil line (4) to adapter (5) and restricted tee (3).

c. Connect oil line (2) to adapter (1) and restricted tee(3).

d. Connect oil line (9) to elbow (10) on oil filter adapter (19) and restricted tee (14).

**7-51. Oil Filler Tube (Figs. 7-18 and 7-19)**

a. Apply adhesive (item 2, Appendix E) to both sides of new gasket (4, fig 7-19).

b. Position gasket (4) on filler tube (3).

c. Position both gasket and filler tube on engine crankcase. Install two capscrews (1) and lockwashers (2), and tighten.

d. Position fuel filter adapter (1, fig. 7-18) and fuel filters (2) onto engine crankcase. Install three capscrews (3) and lockwashers (4), and tighten.

**7-52. Exhaust Manifold (Fig. 7-17)**

a. Install exhaust manifold (4) and four new gaskets (5) to cylinder heads. Secure with four lock tabs (1), eight capscrews (2), and eight washers (3). Tighten capscrews evenly to 13–15 lb.-ft. Bend lock tabs (1) up to prevent capscrews (2) from loosening.

b. Replace high temperature switch (para 7-57). Replace exhaust pipe (para 4-77).

c. Replace air shutter assembly (para 7-60),

**7-53. Engine Junction Box and Electrical Wiring**

Refer to paragraph 4-19 for installation.

**7-54. Fuel Stop Solenoid (Fig. 7-16)**

a. Connect lead from control switch terminal on solenoid.

b. Position solenoid on bottom cylinder pan and install two screws. Be sure ground lead is installed by one of the screws.

c. Adjust solenoid plunger (para 7-85).

**7-55. Fuel Lines (Fig. 7-15)**

a. Install injector lines (7).

b. Install manifold (4) and return lines (5).

c. Install injector nozzle return lines (3).

**7-56. Governor Linkage (Fig. 7-1 4)**

a. Using screws (13), lockwashers (14), and nuts (15), attach governor control bracket (12) to engine backplate.

b. Insert end of throttle rod (7) through two washers (20) and into hole in control arm (19). Secure with cotter pin (5).

c. Attach throttle cable (11) to throttle arm (10)with clevis pin (9) and cotter pin (8).

**NOTE**

**If new ball joints are used on linkage, position the new joints to obtain the same length or 1/32 inch more than the old linkage (one turn equals 1/32 inch). If old linkage length is not available, position new ball joints about midway on each end of linkage, then lengthen 1/8-inch.**

d. Attach governor arm (3) to governor shaft (4) and install spring (17). Attach opposite end of governor arm to governor linkage (1). Connect governor linkage (1) to injector pump (2).

**7-57. High Temperature Switch (Fig. 7-1 3)**

a. Assemble items 5-13 in order shown in figure 7-13.

b. Install assembled pressure switch by securing switch bracket (10) with two capscrews (3) and washers(4).

c. Connect two leads (1 and 2) to high temperature switch.

d. Remove block from louvers on air shutter.

### 7-58. Tachometer Sensor (M967, M969, and M970) (Fig. 7-12)

- a. Position sensor in mounting bracket and install bottom jam nut.
- b. Connect two electrical leads to terminals on sensor.
- c. Loosen top jam nut. Using a feeler gage between sensor head and flywheel, adjust sensor to obtain a gap of .030- to .035-inch (fig. 7-42). Tighten both jam nuts securely. Recheck gap setting.
- d. Install blower housing (para 7-60).
- e. Recalibrate the tachometer para 7-82).

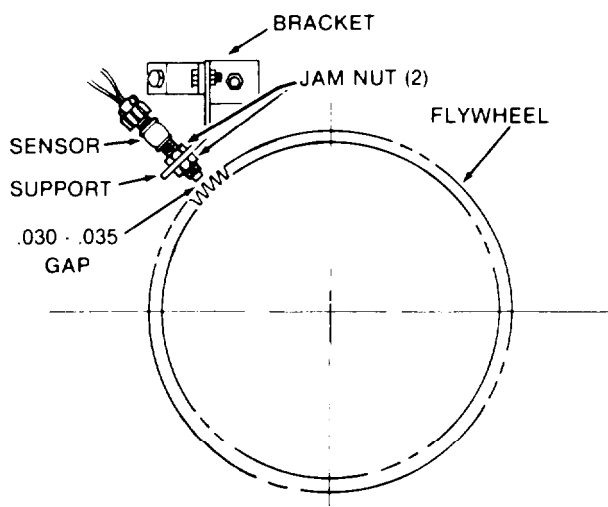

TA100114

Figure 7-42. Tachometer Sensor Gap.

### 7-59. Oil Cooler and Lines (Fig. 7-1 1)

- a. Attach hoses (8 and 9, fig. 7-11) to oil cooler if previously removed.
- b. Install oil cooler (6) on mounting bracket (7) and secure with capscrews (3), lockwashers (4), and nuts (5).
- c. Mount mounting bracket (7) to engine using two capscrews (10).
- d. Insert hoses (8 and 9) through governor control mounting bracket (12, fig. 7-14).

e. Attach hoses (8 and 9) to valve of oil filter adapter (11).

f. Replace self-locking screw (1) and retaining clamps (2).

### 7-60. Air Cooling Shrouding (Figs. 7-9 and 7-1 0)

#### a. Bottom Cylinder Pan (3, Fig. 7-9)

(1) Position bottom cylinder pan (3, fig. 7-9) on engine. Install two screws (30).

(2) Replace all fuel lines (para 7-55).

(3) Connect governor arm (3, fig. 7-14) to governor linkage ball joint (22).

(4) Connect the large lead to the manifold heater (para 4-20). Connect the fuel shutoff linkage at the injector pump lever, nylon tube to the oil pressure switch, the two leads to the oil pressure switch, and the hot lead to the fuel stop solenoid (para 4-22).

(5) Attach rear cylinder housing, blower housing, and top air housing cover. Refer to steps b, d, and e.

#### b. Rear Cylinder Housing (1, Fig. 7-9).

(1) Position rear cylinder housing (1, fig. 7-9) on engine. Install three capscrews (28) and three washers (29). Install two screws (27).

(2) If air shutter (fig. 7-8) is installed on engine, install three capscrews (30, fig. 7-44). If air shroud is not installed, do not install capscrews (30).

(3) Attach throttle cable to engine throttle linkage (para 4-75).

#### c. Air Shutter (Fig. 7-8).

(1) Position air shutter on engine and install three capscrews (30, fig. 7-44).

(2) If blower housing is installed, install two screws (29) and washers (31). If blower housing is not installed, do not install the capscrews and washers.

(3) Thread high temperature switch leads through hole in bottom of shutter box and attach to high temperature switch (para 7-57).

(4) Replace high temperature switch (para 7-57).

d. **Blower Housing (6, Fig. 7-9).**

**NOTE**

**Be sure to attach the starter shroud to blower housing.**

(1) Position blower housing (6, fig. 7-9) on engine. Attach to engine using eight capscrews (23), two capscrews (24), two washers (25), capscrews (26), capscrew (21), and lockwasher (22).

(2) Tighten capscrew (20).

(3) Attach engine fan shroud (8, fig. 7-10) to frame (9) and panel (5) with four capscrews (6) and nuts (7).

(4) Attach fuel hoses to fuel tank (para 4-73) and air cleaner hose to air intake manifold (para 4-74).

e. **Top Air Housing (2, Fig. 7-9).**

(1) Position top air housing cover (2, fig. 7-9), and secure to engine with four capscrews (18) and washers (19).

(2) Position lifting bracket (17) and lifting bracket-brace (9) on engine head covers. Secure to engine using spacer (8), capscrew (7), two spacers (16), two vibration cushions (15), two washers (14), and two capscrews (13).

(3) Replace muffler stand (3, fig. 7-10). Attach with five capscrews (1) and nuts (2).

(4) Install muffler (para 4-77). Attach air cleaner hose to air intake manifold para 4-74).

**Section III. REPAIR INSTRUCTIONS**

**7-61. General**

a. This section contains the procedures and specifications for overhaul, reassembly, and checkout of the auxiliary diesel engine components. The procedures require use of precision instruments and machinery, and should only be undertaken by qualified technicians. Special tools are referenced by National Stock Number and Part Number in table 2-1, and should be used where specified. The overhaul procedures are based on the premise that the engine will be restored to a completely serviceable condition as prescribed by maintenance serviceability standards.

b. The diesel engine is a precision-built engine and, therefore, the repair and overhaul standards for component parts have been fixed at extremely close tolerances. The following should apply to all inspection procedures:

(1) The latest inspection equipment, methods, and procedures should be used during component repair and overhaul.

(2) Extreme care must be exercised during all phases of inspection. Repair and overhaul standards must be followed exactly.

**7-62. Cleaning - General**

a. Disassemble engine to major components in accordance with instructions in Section II of Chapter 7.

b. Clean all parts thoroughly and identify location in engine.

c. Maintain cleanliness throughout the overhaul procedures. Diesel engines are intolerant to even minute particles of dirt. Tools and equipment should also be clean.

d. Cover all cleaned components to protect them from dust or dirt.

**CAUTION**

**Ensure that all components are coated with the proper grade of oil as they are assembled. Failure to follow this caution may result in damage to engine.**

e. During assembly of internal engine components, coat all components heavily with oil of the same grade to be used in the crankcase. During the first few moments of operation, the engine will depend upon this lubrication. Refer to Section I of Chapter 3 for proper lubricants.

**7-63. Inspection - General**

a. Clean all parts before inspection.

**NOTE**

**If the cylinder block is cracked, the engine cannot be overhauled. Be certain to save all salvageable components.**

b. Use Magnaflux or die penetrating technique to detect cracks.

c. Inspect all milled surfaces for pitting, burrs, and carbon or dirt buildup. Remove all burrs from bolt holes on machined or milled surfaces.

d. Inspect all mating surfaces. Be certain that they are clean and smooth to ensure proper gasket sealing.

#### 7-64. Air Cooling Shrouding

##### a. Inspect On Equipment.

(1) *Shutter Assembly.* Inspect shutter assembly (fig. 7-43) for physical damage. Check for debris within assembly. Check for smooth operation of shutters when moved manually. Check for chipped paint or rust.

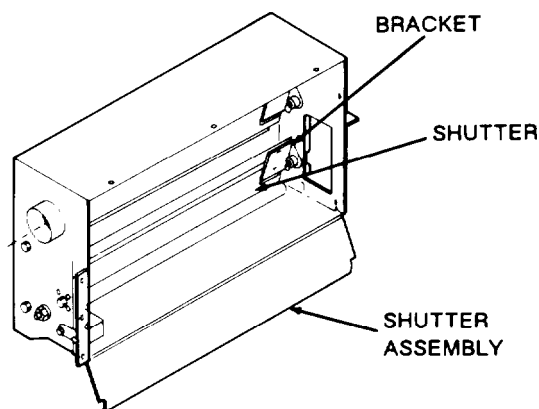

TA502327

Figure 7-43. Shutter Assembly.

(2) *Bracket Assembly.* Inspect that brackets (fig. 7-43) are securely mounted to shutters. Check that bracket bearings are not excessively worn.

(3) *Shutters.* Inspect shutters (fig. 7-43) for physical damage and secure mounting to brackets.

(4) *Air Shrouding Door.* Inspect rear cylinder housing (1, fig. 7-9), top air housing cover (2), air housing bottom pan (3), and panel door (4) for physical damage.

(5) *Grille.* Inspect grille (5, fig. 7-9) for secure mounting to blower housing (6).

(6) *Blower Housing.* Inspect blower housing (6, fig. 7-9) for physical damage. Check for secure mounting of blower housing to engine.

##### b. Repair.

### **WARNING**

**Dry cleaning solvent P-D-680 is toxic and flammable. Always wear protective goggles and gloves, and use only in a well-ventilated area. Avoid contact with skin, eyes, and clothes, and DO NOT breathe vapors. DO**

**NOT use near open flame or excessive heat. The solvent's flash point is 100°F-138°F (38°C-59°C). If you become dizzy while using cleaning solvent, immediately get fresh air and medical help. If solvent contacts eyes, immediately wash your eyes with water and get medical aid.**

(1) *Shutter Assembly.* Refer to paragraph c(1) to replace defective components. Repair physical damage by removing dents and welding breaks in shutter assembly box. Clean repaired area with dry cleaning solvent (item 11, Appendix E). Paint as required.

(2) *Bracket Assemblies.* Replace bracket (4, 5, and 6, fig. 7-44) or bearings (7) if required.

(3) *Shutters.* Bump out dents and straighten shutters (3, fig. 7-44) if required. Clean with dry cleaning solvent (item 11, Appendix E) and repaint if necessary.

(4) *Air Shrouding and Door.* Clean shrouding and door with dry cleaning solvent (item 11, Appendix E) and paint if necessary.

(5) *Grille.* Inspect grille (5, fig. 7-9) or secure mounting to blower housing (6).

(6) *Blower Housing.* Bump out dents in blower housing (6, fig. 7-9), repair cracks with welds if necessary, and clean with dry cleaning solvent (item 11, Appendix E). Paint as required.

##### c. Disassembly of Shutter Assembly (Fig. 7-44).

(1) *Shutters.* Remove eight screws (1, fig. 7-44) and nuts (2) attaching shutters (3) to bracket assemblies (4, 5, and 6). Remove shutters.

##### (2) Brackets.

(a) Remove brackets (4). Remove bearings (7) by removing screw (9) and washers (8).

(b) Remove clips (10) that retain lower rod (11) in bracket (6) and pivot arm (12). Remove lower rod and bracket (6). Remove bearing (7) by removing screw (9) and washer (8).

(c) Remove nut (13), clip (14), and ball arm assembly (15). Remove bracket (5) and associated bearing (7), screw (9), and washer (8).

(d) Disconnect springs (16 and 17) from pivot arm (12). Remove pivot arm (12) by removing nut (18), lockwasher (19), flatwasher (20), washer (21), bearing (22), and bolt (23).

(3) *Shutter Thermo Power Unit.* Compress spring (24) and remove washers (25) and thermo power unit (26).

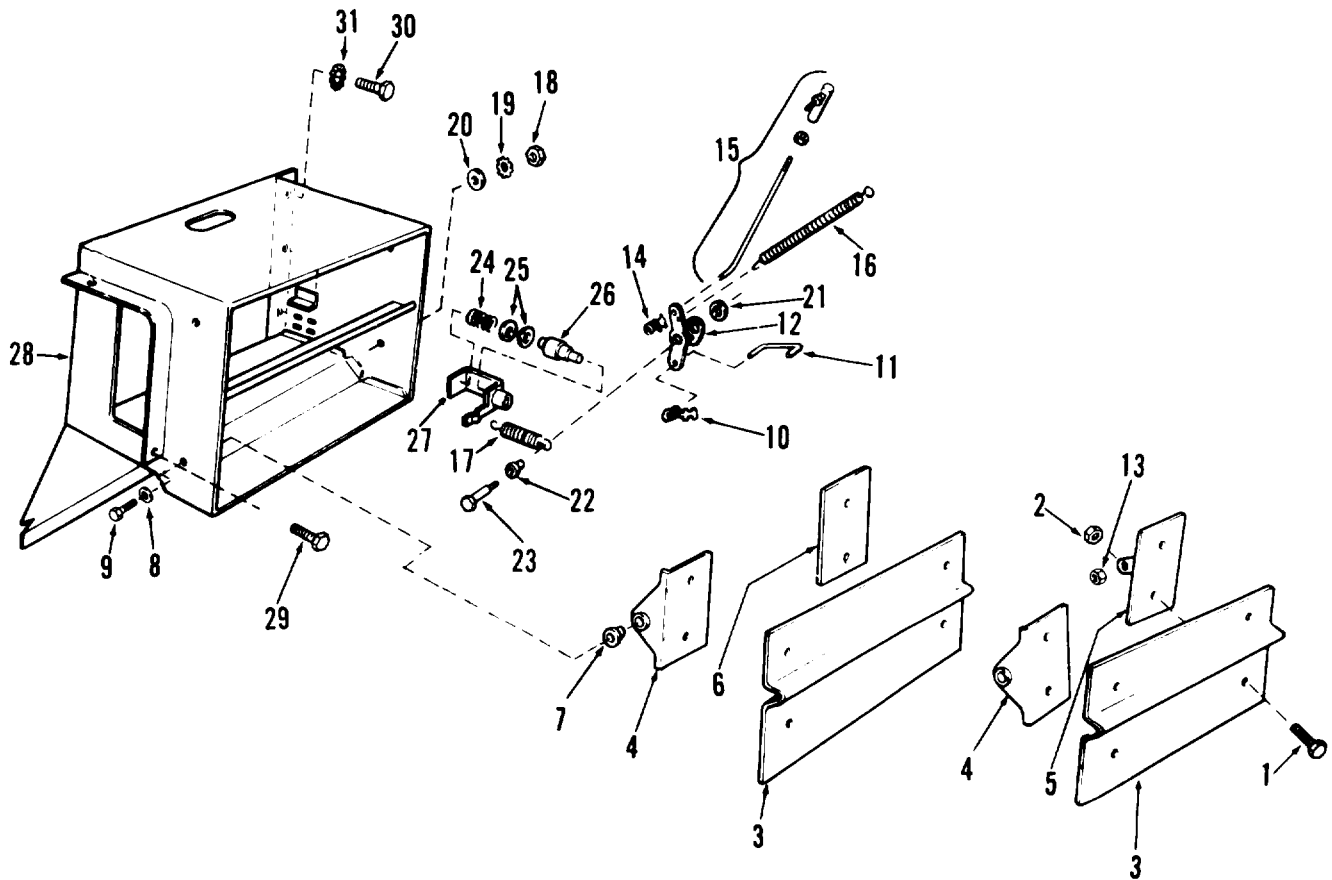

- |                |                       |                |                      |
|----------------|-----------------------|----------------|----------------------|
| 1. Screw (8)   | 9. Screw (4)          | 17. Spring     | 25. Washer (2)       |
| 2. Nut (8)     | 10. Clip (2)          | 18. Nut        | 26. Thermopower unit |
| 3. Shutter (2) | 11. Lower rod         | 19. Lockwasher | 27. Bracket          |
| 4. Bracket (2) | 12. Pivot arm         | 20. Flatwasher | 28. Box              |
| 5. Bracket     | 13. Nut               | 21. Washer     | 29. Capscrew (2)     |
| 6. Bracket     | 14. Clip              | 22. Bearing    | 30. Capscrew (3)     |
| 7. Bearing (4) | 15. Ball arm assembly | 23. Bolt       | 31. Washer (3)       |
| 8. Washer (4)  | 16. Spring            | 24. Spring     |                      |

TA100115

**Figure 7-44. Disassembled Air Shutter.**

*d. Reassembly of Shutter Assembly.*

(1) *Shutter Thermo Power Unit.* Insert thermo power unit in bracket (27, fig. 7-44). Place two washers (25) over end of power unit. Compress spring (24) and install between bracket (27) and washers (25).

(2) *Brackets.*

(a) Reassemble pivot arm (12) using bolt (23), bearing (22), washer (21), flatwasher (20), lockwasher (19), and nut (18). Connect springs (16 and 17) to pivot arm.

(b) Mount bracket (5) to box (28) using bearing (7), screw (9), and washer (8). Be careful not to confuse bracket (5) with bracket (6). Connect ball arm assembly (15) to bracket (5) and pivot arm (12), using clip (14) and nut (13).

(c) Mount bracket (6), along with bearing (7), screw (9), and washer (8). Mount lower rod (11) to bracket (6) and pivot arm (12) using clips (10).

(d) Install brackets (4), bearings (7), screws (9), and washers (8).

(3) *Shutters.* Mount shutters using eight screws (1) and nuts (2). Ensure that adequate clearance between

shutters and shutter box sides is maintained and that brackets (4) are seated against shoulder of bearings (7) prior to tightening screws (1) and nuts (2). Check shutters to ensure that they fully open and close without bending.

### 7-65. Oil Cooler and Lines

#### **WARNING**

**Dry cleaning solvent P-D-680 is toxic and flammable. Always wear protective goggles and gloves, and use only in a well-ventilated area. Avoid contact with skin, eyes, and clothes, and DO NOT breathe vapors. DO NOT use near open flame or excessive heat. The solvent's flash point is 100°F-138°F (38°C-59°C). If you become dizzy while using cleaning solvent, immediately get fresh air and medical help. If solvent contacts eyes, immediately wash your eyes with water and get medical aid.**

a. *Cleaning.* Clean oil cooler (fig. 7-45) inside and out using dry cleaning solvent (item 11, Appendix E). Flush piping by forcing diesel fuel through oil cooler inlet. Drain thoroughly and flush again with clean oil (para 7-62).

b. *Inspection and Repair.*

(1) Inspect on cooler (fig. 7-45) for bent or damaged cooling fins, and cracked or defective welds which may result in loss of oil. If defective, replace oil cooler.

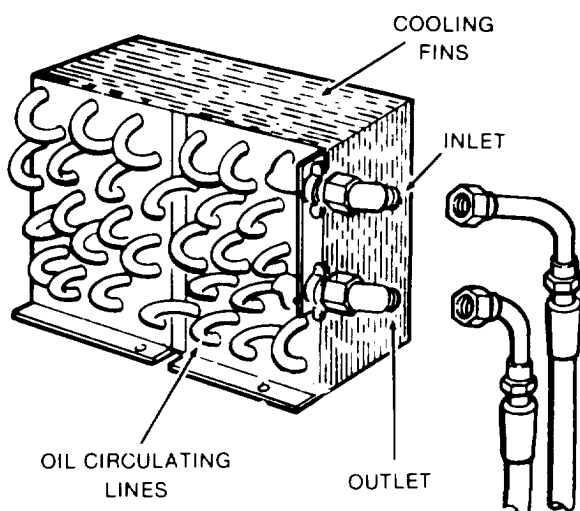

TA100116

Figure 7-45. Oil Cooler.

#### **WARNING**

**Particles blown by compressed air can be dangerous. Be certain to direct air stream away from the user and other personnel in the area.**

(2) Using compressed air at 15 psi, test oil cooler under water for leaks. Dry outside of oil cooler using compressed air under moderate pressure, and flush inside of oil cooler using diesel fuel. Drain thoroughly and flush again with clean oil (para 7-62).

(3) Straighten all bent cooling fins.

### 7-66. Governor Linkage

a. Inspect governor linkage components (fig. 7-14) for damaged threads, bent linkage rod, defective spring, and excessive wear. Replace damaged components.

b. Inspect snap-in ball joints for tightness. If ball joints are worn and come apart easily, replace ball joints.

### 7-67. Fuel Stop Solenoid

a. *Disassembly (Fig. 7-16).*

(1) Remove screw and lockwasher securing ground lead to solenoid, and remove lead (fig. 7-16).

(2) Remove adjusting screw and jam nut.

(3) Remove retaining rings and plunger cover.

(4) Remove spring.

(5) Remove plunger, retainer, and gasket.

b. *Cleaning and Inspection.*

(1) Wipe all components clean, and inspect for damaged threads, excessive wear, and defective spring.

(2) Inspect waterproof solenoid plunger cover for deterioration, cracks, and small holes. Replace all defective components.

(3) Inspect ground lead for damage due to sharp bends, kinks, or excessive wear.

c. *Assembly (Fig. 7-16).*

(1) Position upper retaining ring in waterproof solenoid plunger cover, and insert plunger spring into cover over the retaining ring.

(2) Insert grooved end of solenoid plunger into retainer.

**CAUTION**

**The bottom of the plunger cover must be sandwiched between the two retainers to ensure a watertight installation.**

(3) Slide the spring, retaining ring, and solenoid plunger cover over the plunger. Position bottom retaining ring over the plunger and against bottom of cover.

(4) Secure assembled components with external retaining ring.

**NOTE**

**During final installation of the fuel stop solenoid, the gasket must be installed between the solenoid retainer and the solenoid.**

(5) Connect ground lead to solenoid with screw and lockwasher.

**7-68. Oil Filter Adapter**

*a. Disassembly (Fig. 7-20).*

(1) Remove the two 90° tube elbows (11, fig. 7-20).

(2) Remove inverted elbow (10), elbow (15), and elbow (27).

(3) Remove three screws (21) and lockwashers (22) securing oil bypass cover (23) to the adapter (19). Remove the cover.

(4) Remove the spring (25) and thermostat (26). Discard the thermostat.

(5) Remove and discard the bypass cover gasket (24).

*b. Cleaning.*

**WARNING**

**Dry cleaning solvent P-D-680 is toxic and flammable. Always wear protective goggles and gloves, and use only in a well-ventilated area. Avoid contact with skin, eyes, and clothes, and DO NOT breathe vapors. DO NOT use near open flame or excessive heat. The solvent's flash point is 100°F-138°F (38°C-590°C). if you become dizzy while using cleaning solvent, Immediately get fresh air and medical help. If solvent contacts eyes,**

**immediately wash your eyes with water and get medical aid.**

(1) Clean gasket mating surfaces using dry cleaning solvent (item 11, Appendix E). Wipe dry using a clean, lint-free cloth (item 24, Appendix E).

**WARNING**

**Particles blown by compressed air can be dangerous. Be certain to direct air stream away from the user and other personnel in the area.**

(2) Flush oil ports and thread holes clean with diesel fuel (item 14, Appendix E). Air dry ports using clean, filtered, compressed air under moderate pressure of approximately 15 psi.

(3) Soak all metal parts in a clean receptacle containing hydraulic fluid (item 18, Appendix E). Wipe dry using a clean, lint-free cloth (item 24, Appendix E). Clean parts with compressed air as in step (2).

(4) Coat all components with oil before assembly. Refer to Section I, Chapter 3 for the proper lubricant.

*c. Inspection and Repair.*

(1) Visually inspect adapter assembly for nicks or dents on the gasket mating surfaces. Inspect for cracks.

(2) Inspect threaded holes for damaged or excessively worn threads. Replace adapter if defective.

*d. Assermbly (Fig. 7-20).*

(1) Install spring (25, fig. 7-20) and new thermostat (26) in the adapter assembly.

(2) Position the cover (23) and new cover gasket (24) over the thermostat and spring. Secure gasket and cover to adapter assembly with three screws (21) and lockwashers (22). Tighten screws securely.

(3) Install inverted elbow (10). Tighten elbow securely.

(4) Install two elbows (11). Tighten elbows securely to a position approximately 20° left of top center.

(5) Install elbow (15). Tighten elbow securely to a position 90° right of top center.

(6) Install elbow (27). Tighten elbow securely to the position shown in figure 7-20.



**7-69. Fuel Injection Pump (Fig. 7-46)**

a. *Disassembly (Fig. 7-46).* All work on injection equipment MUST be performed in the cleanest location possible. No filing, scraping, or sawing should be done on the bench where repairs are made.

**WARNING**

**Dry cleaning solvent P-D-680 is toxic and flammable. Always wear protective goggles and gloves, and use only in a well-ventilated area. Avoid contact with skin, eyes, and clothes, and DO NOT breathe vapors. DO NOT use near open flame or excessive heat. The solvent's flash point is 100°F-138°F (38°C-590°C). if you become dizzy while using cleaning solvent, immediately get fresh air and medical help. if solvent contacts eyes, immediately wash your eyes with water and get medical aid.**

(1) Clean all external dirt and grease from the pump.

**CAUTION**

**The pump housing must NEVER be clamped in a vise.**

**NOTE**

**A special mounting fixture (table 5-2) must be made to adequately secure the pump housing.**

(2) Clamp the mounting fixture in a suitable vise.

(3) Install the pump housing into the mounting hydraulic head fixture with two two - 18 UNC hex head screws.

(4) Release lock tabs (2) and remove the two control unit retaining plate screws (1), tab washers (2, fig. 7-46), and the control unit retaining plate and stop assembly (3). Carefully pull the control unit assembly (4) with plunger sleeve pin (5) out of the pump housing (6). Plunger sleeve pin occasionally may have to be removed separately. Use needle nose pliers or magnetic pencil.

(5) Remove the delivery valve cap nut (7) and gasket (8).

(6) Remove the delivery valve holder(9), then lift out the delivery valve spring (10), delivery valve (11), delivery valve body (42), and delivery valve spacer (12).

(7) Remove the hydraulic head locating screw (13) and copper gasket (14).

(8) Remove four head retaining screws (15) and four head retaining clamps (16). Carefully rest tappet on clean surface and using shaft head, hammer pump body assembly until hydraulic head assembly separates from body assembly.

(9) Remove the O-rings (18 and 19) from the hydraulic head and the pump housing.

(10) Remove the tappet (20) and related O-ring (21) from the face gear bore.

(11) Remove the spring ring (22) and the plunger button (23) from the end of the plunger (the plunger is part of hydraulic head assembly).

(12) Invert the hydraulic head assembly and place it in a suitable arbor press (fig. 7-47).

(13) Position tool TSE 76215 (table 5-1) over the lower spring seat washer (24, fig. 7-46) and depress the plunger spring, then remove the lower seat (25).

(14) Remove lower spring seat washer (24, fig. 4-46) and plunger spring (26).

(15) Place the hydraulic head assembly on a bench. Use two screwdrivers to pry off the face gear (28), then remove the thrust washer (29).

**NOTE**

**The plunger, plunger sleeve and hydraulic head are mated parts and must always be kept together.**

(16) Do not remove the plunger (35) from the hydraulic head fixture with two two - 18 UNC hex head screws.

b. *Inspection (Fig. 7-46).*

(1) Place the delivery valve assembly in test fixture TSE 76226 (table 5-1), and secure in a suitable vise (fig. 7-48).

(a) Insert the delivery valve spring (1) and the delivery valve holder (2). Tighten the delivery valve holder to 70-75 Ib.-ft. Figure 7-77 illustrates the components that are to be assembled to test fixture TSE 76226 (3).

1. Retaining plate screw (2)
2. Tab washer (2)
3. Control unit retaining plate and stop assembly
4. Control unit assembly
5. Plunger sleeve pin
6. Pump housing
7. Cap nut
8. Gasket
9. Delivery valve holder
10. Valve spring
11. Delivery valve
12. Valve spacer
13. Locating screw
14. Copper gasket
15. Head retaining screws (4)
16. Head retaining clamps (4)
17. Head assembly
18. Head O-ring
19. Head O-ring
20. Tappet
21. O-ring
22. Button spring ring
23. Plunger button
24. Lower spring seat washer
25. Seat
26. Plunger spring
27. Spring ring
28. Face gear
29. Thrust washer
30. Plunger drive pin
31. Timing screw
32. Gasket
33. O-ring
34. Plunger sleeve
35. Plunger
36. Control unit bore
37. Pin
38. Flatwasher
39. Lockwasher
40. Nut
41. Control unit lever
42. Delivery valve body
43. Fitting (4)
44. Elbow

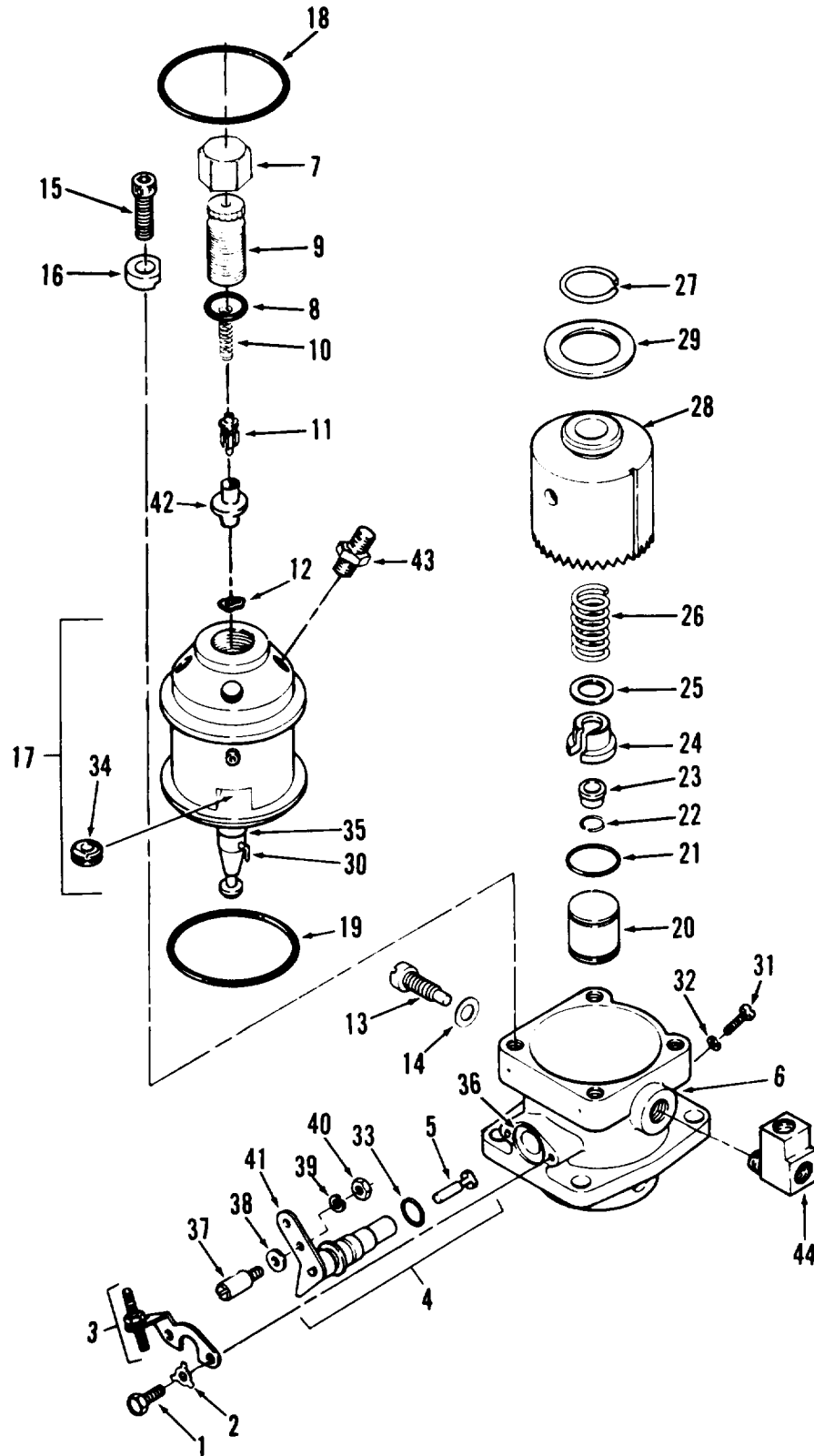
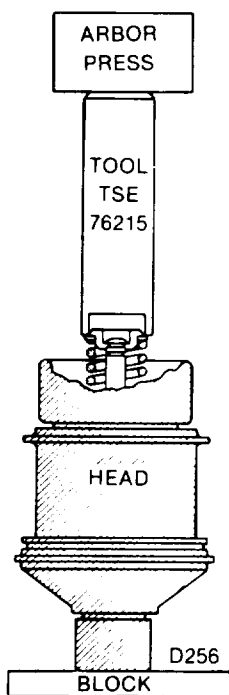

Figure 7-46. Disassembly of Fuel Injection Pump.

TA502328



TA100118

Figure 7-47. Removing Lower Spring Seat.

1. Spring
2. Delivery valve holder
3. TSE 76226 fixture
4. Delivery valve
5. Delivery valve body
6. Delivery valve spacer

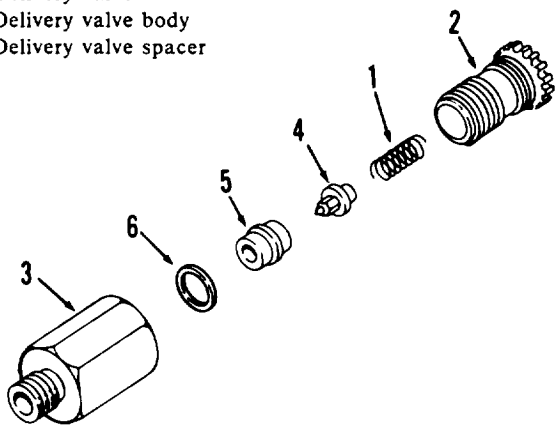

TA100119

Figure 7-48. Delivery Valve Test Assembly.

**NOTE**

Always check to ensure that all external connections are tight and that the nozzle test stand is in good order.

(b) Attach test fixture TSE 76226 (3) to a manually operated Nozzle Test Stand.

(c) Delivery valve opening pressure is 300-600 psi. Delivery valve must hold 275 psi for 30 seconds. Remove delivery valve assembly from test fixture. The delivery valve spring (1) must be free of nicks or wear (flat spots). Replace fuel injection pump if springs are nicked or worn.

**CAUTION**

Lapping compound must not come in contact with the relief piston during the lapping operation, and all lapping compound must be removed before installing the delivery valve assembly into the hydraulic head.

(d) If the delivery valve assembly is leaky, the delivery valve seat may be lapped to its corresponding seat in the delivery valve body with a small quantity of suitable lapping compound.

(2) If the plunger bottom (23, fig. 7-46) is grooved, ridged, scored, or exhibits an uneven wear pattern, it must be replaced.

(3) Inspect the tappet (20) for possible wear at the contact areas. The primary contact areas are the tappet contact area and the cam contact area (fig. 7-49). Replace the tappet if wear indentations exceed 0.002-inch. The tappet thickness measured between the plunger button contact surface and the cam contact area must be 0.207-inch or larger.

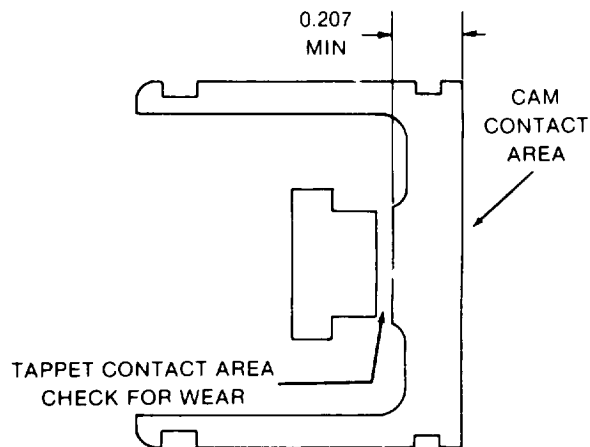

TA100120

Figure 7-49. Inspecting Tappet

(4) The pump housing (6, fig. 7-46) should be washed in a cleaning solvent. Check all the screw threads in the housing; damaged threads can be repaired using thread inserts:

(5) Examine the pump housing for cracks or other damage which will cause oil leakage. Replace complete pump if pump housing is damaged.

(6) Rotate lever (41) while holding sleeve of control unit assembly (4). Shaft must turn freely. If a binding condition exists, wash assembly in a cleaning agent, and repeat procedure. If binding condition is still present, injection pump must be replaced. Also ensure that weld holding lever to shaft is intact.

(7) The flat end of plunger sleeve pin (5) must be checked for clearance in the mating slot of the plunger sleeve. If the clearance is greater than 0.0015-inch, the injection pump must be replaced.

c. **Reassembly (Fig. 7-46).**

**CAUTION**

**Be careful not to damage O-ring gaskets.**

(1) After all parts have been thoroughly cleaned and inspected, dip the individual parts in clean diesel fuel (item 14, Appendix E).

(2) Invert the hydraulic head (17, fig. 7-46) and place it on a clean bench so that the head locating slot is forward.

(3) Align the plunger drive pin (1, fig. 7-50) into the plunger (2) so that the head of the plunger drive pin is in line with the distributor slot. Turn the plunger drive pin until its long side is parallel to the length of the plunger with long end up.

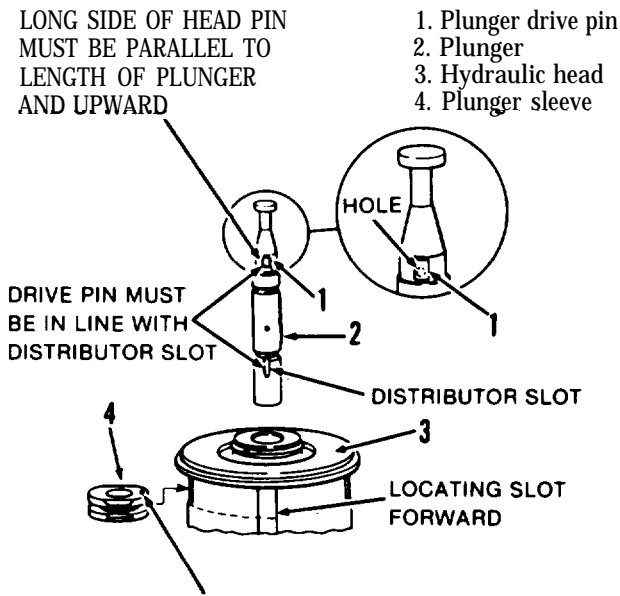

TA100121

Figure 7-50. Assembling Hydraulic Head.

(4) Apply a thin coat of petrolatum (item 23, Appendix E) to the thrust washer (29, fig. 7-46) and assemble it to the hub on the face gear (28).

(5) Carefully center spring ring (27) on hydraulic head assembly.

(6) Position the face gear (28) and thrust washer (29) over the end of the plunger (35), and aline the head of the plunger sleeve pin (5) with its mating slot located on the inside of the face gear (28).

**CAUTION**

**Do not use extreme pressure. If gear will not snap Into place easily, remove gear and check to see that spring ring (27) Is centered, and that plunger drive pin (1, fig. 7-50) is properly alined.**

(7) Press the face gear (28, fig. 7-46) onto the hydraulic head (17). Ensure that the spring ring (27) snaps into its mating groove in the face gear (28). Manually operate the plunger up and down. Free movement of the plunger indicates that the face gear has been correctly assembled to the hydraulic head.

(8) With head still in an inverted position, raise plunger (35) to its highest position.

(9) Apply grease (item 17, Appendix E) to exposed portion of plunger to keep it in its highest position.

(10) Install spring (26) and spring retaining washer (24). Snap spring seat (25) into place on the head of plunger (35).

(11) Install the plunger button (23) onto the end of the plunger and secure it by snapping the spring ring (22) into its mating groove in the lower spring seat (25).

(12) Ensure that the button spring ring (22) fits tightly into its groove in the lower spring seat (25). Loose spring rings (22) must be replaced.

(13) Apply thin coat of petrolatum (item 23, Appendix E) to inside of tappet (20). Insert the tappet (20) into the face gear (28).

(14) Apply a thin coat of petrolatum (item 23, Appendix E) to the hydraulic head O-rings (18 and 19). Insert O-ring into the head bore of the pump housing (6). Install the O-ring into its groove on the upper portion of the hydraulic head. Ensure that O-rings seat properly.

(15) Clamp pump mounting fixture in a vise, install pump housing fixture, then carefully insert the

hydraulic head into the pump housing so that the locating slot in the hydraulic head is in line with the locating screw hole in the pump housing (not seating).

(16) Install the head locating screw gasket (14) and the head locating screw (13) into the locating screw hole in the pump housing (6). Slight repositioning of the hydraulic head may be necessary to properly install the head locating screw. Do not use force. Tighten screw (13) to 90-100 lb.-in. Install head retaining clamps (16) and screws (15). Alternately tighten screws (15) at opposite corners of housing (6) to properly seat the head assembly (17) in the housing. Tighten screws (15) to 13-15 lb.-ft. Insert the timing screw (31) and its gasket (32) into the timing screw hole in the pump housing. Tighten the timing screw to 20-25 lb.-in.

(17) Install the delivery valve spacer (12), delivery valve assembly (11), delivery valve spring (10), and delivery valve holder (9). Tighten delivery valve holder to 70-75 lb.-ft. Install delivery valve cap nut (7) and gasket (8). Tighten nut to 55-60 lb.-ft.

(18) Insert pin (37, fig. 7-46) and flatwasher (38) into lower hole of lever on control unit assembly (4), and secure with lockwasher (39) and nut (40). Tighten nut to 20-25 lb.-in.

(19) Ensure that O-ring (33) is seated in control unit. Apply oil to plunger sleeve pin (5) and insert the plunger sleeve pin (5) into the control unit assembly (4).

(20) Place pump in horizontal position with control unit bore (36) facing up.

(21) Center the plunger sleeve (34) in the control unit bore (36). Position plunger sleeve pin (5) so that the flats align with the groove in the control sleeve (34), and the electric pencil mark (dot) faces the top of the pump.

**CAUTION**

**Do not use force. If flange is not seated on pump housing, rotate arm both ways with finger pressure pushing control unit in.**

**NOTE**

- **Rotate the control unit lever (41, fig. 7-46) through a 360° arc to ensure that the control unit assembly is correctly installed. Failure to rotate 360° indicates that the**

**plunger sleeve pin (5) is not engaging the plunger sleeve slot.**

- **If control unit will not seat, pull it out and repeat steps (20) through (22).**

(22) Insert control unit assembly (4) into housing (6), pressing gently until control unit seats.

(23) Install control unit assembly retaining plate, as shown in figure 7-51, using two tab washers and two screws. Tighten screws to 20-25 lb.-in., and bend locking tabs over screws.

**"BENT OVER" TAB MUST BE HELD AGAINST PLATE, AS SHOWN, DURING TORQUING AT ASSEMBLY.**

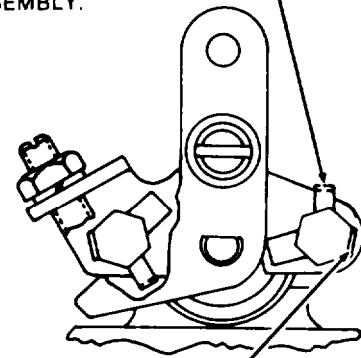

**BEND OVER ONE TAB AGAINST SIDE OF SCREW HEAD**

**TA100122**

**Figure 7-51. Control Unit Assembly.**

**7-70. Fuel Injectors**

- a. *Disassembly (Fig. 7-52).*

**CAUTION**

**Never clamp injector in a vise which has hardened jaws. Damage to Injector would result.**

**NOTE**

- **When removing and disassembling fuel injectors, separate and label components of each injector. Never interchange components of injectors.**
- **DO not remove nozzle unless replacement is required.**

(1) Secure fuel injector in a soft-jawed holding fixture, and remove nozzle cap (1), valve (2), and nozzle (3).

(2) Should nozzle be removed, replace nozzle cap (1) onto nozzle holder (4) loosely to protect lapped surfaces of nozzle holder.

(3) Remove plug (5) from protective cap (6).

(4) Unscrew protective cap (6) from adjusting screw (8). Remove copper gasket (7).

(5) Unscrew adjusting screw (8) from nozzle holder (4). Be careful-adjusting screw is under spring pressure.

(6) Remove spring (9) and nozzle spindle (10).

*b. Cleaning.*

(1) Clean fuel injector parts in a clean room on a clean bench. Provide a pan of clean diesel fuel (item 14, Appendix E) and a supply of lint-free cloths (item 24, Appendix E).

(2) Never use hard or sharp tools, emery paper, grinding powder, or abrasives of any kind.

(3) If necessary, clean outer surfaces of nozzle cap with a brass brush, but do not attempt to scrape carbon from nozzle surfaces because severe damage to spring hole can result.

(4) Use a soft, oil-soaked cloth to clean nozzle valve. Clean interior of nozzle cap nut.

*c. Inspection.* Inspect tappet surfaces of nozzle holder for nicks or roughening. If damaged, replace nozzle holder.

*d. Repair.* If cleaning will not eliminate an injector defect, replace injector.

*e. Assembly (Fig. 7-52).*

(1) Secure nozzle holder in a suitable holding fixture.

(2) Install nozzle spindle (10) into nozzle holder (4).

(3) Install spring (9) into nozzle holder and then screw adjusting screw (8) into nozzle holder. Do not tighten.

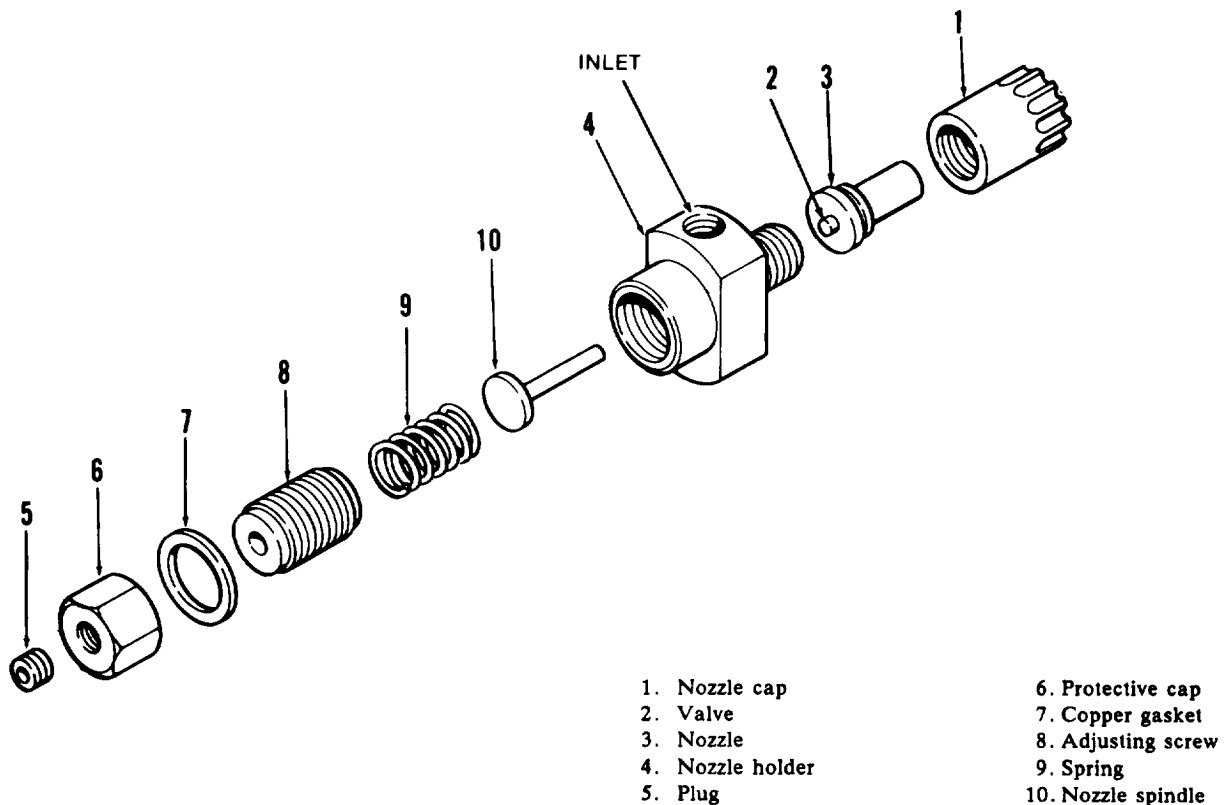

TA100123

Figure 7-52. Disassembled Fuel Injector

(4) Install copper gasket (7) over the adjusting 7-71. Rocker Arm Covers screw (8).

(5) Screw protective cap (6) onto adjusting screw (8), but do not tighten.

(6) Rinse valve (2) and nozzle (3) thoroughly in clean diesel fuel (item 14, Appendix E) before assembly. Valve should slide back to seat without aid when nozzle is held at 45° angle.

(7) Remove all pressure on nozzle spring (9) by loosening adjusting screw (8).

(8) Install valve (2) and nozzle (3) into nozzle cap (1).

(9) Install nozzle cap (1) onto nozzle holder loosely.

**CAUTION**

**When tightening nozzle cop nut, do not contact valve in nozzle.**

(10) Place centering sleeve TSE 773 (table 5-1 and fig. 7-53) over nozzle for initial tightening. Remove centering sleeve after initial tightening to prevent it from binding between nozzle and cap nut, and tighten nozzle cap nut to 50-55 lb.-ft.

(11) Adjust opening pressure of nozzle (para 7-87).

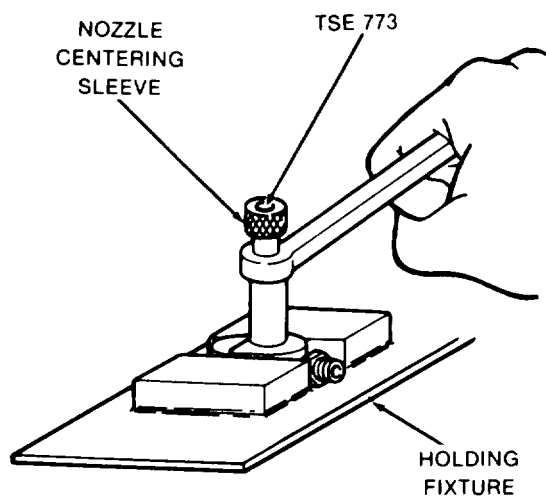

TA100124

Figure 7-53. Centering Sleeve Installation.

**WARNING**

**Dry cleaning solvent P-D-680 is toxic and flammable. Always wear protective goggles and gloves, and use only in a well-ventilated area. Avoid contact with skin, eyes, and clothes, and DO NOT breathe vapors. DO NOT use near open flame or excessive heat. The solvent's flash point is 100°F-138°F (38°C-59°C). If you become dizzy while using cleaning solvent, immediately get fresh air and medical help. If solvent contacts eyes, immediately wash your eyes with water and get medical aid.**

a. *Cleaning.*

(1) Clean rocker arm cover gasket mating surface (fig. 7-54) using dry cleaning solvent (item 11, Appendix E). Ensure that mating surface is cleaned free of all excess gasket material. Wipe dry using a lint-free cloth (item 24, Appendix E).

(2) Flush rocker arm cover oil line with diesel fuel (item 14, Appendix E) and clean out four drain holes using a fine cleaning wire (fig. 7-54).

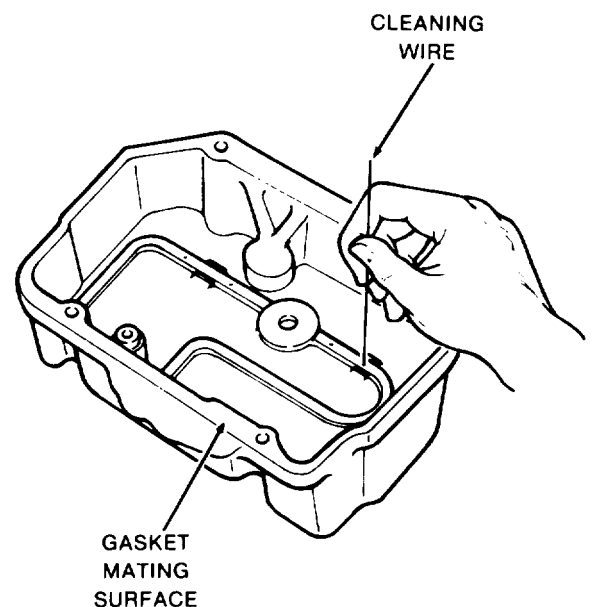

TA100125

Figure 7-54. Cleaning Rocker Arm Cover.

**WARNING**

**Particles blown by compressed air can be dangerous. Be certain to direct air stream away from the user and other personnel in the area.**

(3) Dry oil inlet using clean, filtered, compressed air under moderate pressure of approximately 15 psi.

*b. Inspection and Repair.*

(1) Visually inspect rocker arm cover for nicks or dents on the gasket mating surface. Inspect cover for cracks, particularly around the area of the lifting bracket bolt hole. Inspect bolt holes for damaged or excessively worn threads. Replace rocker arm cover assembly if damaged.

(2) Inspect oil line for deep nicks or dents that may obstruct oil flow. Inspect line for cracks or punctures. Replace oil line if defective.

**7-72. Cylinder Head**

*a. Disassembly (Fig. 7-55).*

(1) Remove valve stem cap (1).

(2) Using a valve spring compressor (fig. 7-55), depress the valve spring (5, fig. 7-55) and remove both halves of the valve stem lock (2).

(3) Release valve spring compressor and remove spring retainer (3), valve spring (5), and valve (8 or 10)

**NOTE**

**The seal assemblies with retainers are installed on the intake valve guides only.**

(4) Remove seal assemblies (4).

(5) Repeat steps (1) through (4) to disassemble studs (1) Cylinder Head Casting and Rocker Arm remaining intake and exhaust valve components.

(6) Remove the rocker arm studs (11) only if defective.

**NOTE**

**Removal procedures for the valve guides (6 and 9) and the valve seats (7) will be found in paragraph 7-72c, Inspection and Repair. Do not remove the valve guides or valve seats**

unless inspection shows that they are defective,

*b. Cleaning.*

**WARNING**

**Dry cleaning solvent P-D-680 is toxic and flammable. Always wear protective goggles and gloves, and use only in a well-ventilated area. Avoid contact with skin, eyes, and clothes, and DO NOT breathe vapors. DO NOT use near open flame or excessive heat. The solvent's flash point is 100°F-138°F (38°C-59°C). If you become dizzy while using cleaning solvent, immediately get fresh air and medical help. If solvent contacts eyes, immediately wash your eyes with water and get medical aid.**

(1) Thoroughly clean all components of the cylinder head assembly (fig. 7-55) using dry cleaning solvent (item 11, Appendix E) and a stiff brush.

(2) Check out oil inlet port (15) using a cleaning wire, and flush clean with cleaning solvent.

**WARNING**

**Particles blown by compressed air can be dangerous. Be certain to direct air stream away from the user and other personnel in the area.**

(3) Dry all tapped holes and oil ports using clean, dry, compressed air under moderate pressure of 15 psi.

*c. Inspection and Repair—Cylinder Head Components.*

(a) Inspect cylinder head casting (16, fig. 7-55) using Magnaflux or die penetrating technique to detect cracks.

(b) Inspect all finished surfaces for nicks, scratches, pitting, or excessive wear.

(c) Inspect all tapped holes for worn or damaged threads.



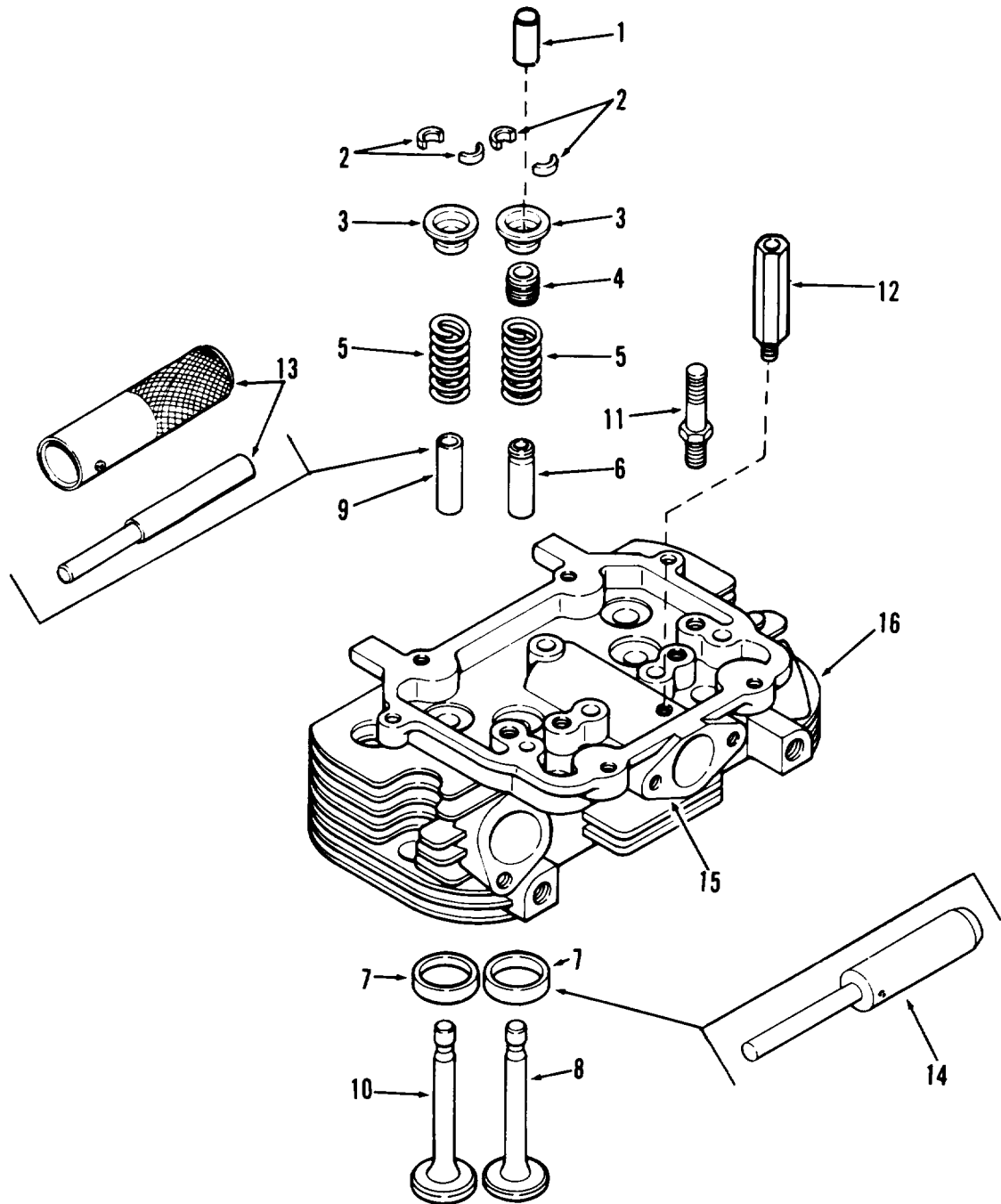

- |                           |                                   |
|---------------------------|-----------------------------------|
| 1. Valve stem cap         | 9. Exhaust valve guide (2)        |
| 2. Valve stem lock (8)    | 10. Exhaust valve (2)             |
| 3. Spring retainer (4)    | 11. Rocker arm stud (4)           |
| 4. Intake valve seal (2)  | 12. Standpipe vent                |
| 5. Valve spring (4)       | 13. Valve guide driver (420-0300) |
| 6. Intake valve guide (2) | 14. Valve seat driver (420-0270)  |
| 7. Valve seat (4)         | 15. Oil inlet port                |
| 8. Intake valve (2)       | 16. Cylinder head casting         |

Figure 7-55. Cylinder Head Assembly.

TA502329

(d) Repair minor damage to the cylinder head castings using a fine file, emery cloth, or crocus cloth (item 4, Appendix E) dipped in dry cleaning solvent (item 11, Appendix E). Repair minor damage to threads using a proper size tap. Do not enlarge the threaded hole. If minor damage cannot be repaired, replace cylinder head casting (16) and valve seats (7). Salvage all other usable components.

(e) Inspect studs (11) for stripped or worn threads, or a bent or loose connection. Replace studs if damaged, using anti-seize compound (item 5, Appendix E). Tighten rocker arm studs to 35-40 lb.-ft.

(2) *Valve Guide and Valve.*

(a) Check for valve stem-to-valve guide allowable clearance by measuring inside diameter of valve guide (6 and 9, fig. 7-55) and outside diameter of the valve stem. Refer to table 7-2 for correct dimensions.

**NOTE**

**If valve stem is worn below minimum tolerances, replace the valve. If new valve fails to correct stem-to-valve guide clearance, replace valve guide.**

(b) Using Correct size valve guide driver tool (table 5-1 and 13, fig. 7-55), remove the valve guide.

(c) Install new replacement valve guide through top of cylinder head using the valve guide driver

tool. Allow valve guide to remain 0.3437-inch from top of cylinder head.

(d) Ream the replacement valve guide, if necessary, to obtain proper valve stem-to-valve guide clearances shown in table 7-2.

(e) Inspect valve (8 and 10, fig. 7-55) for warped stem, pitting, evidence of burning and excessive wear. Replace valves if badly damaged or if valve stem is worn beyond tolerances shown in table 7-2.

**CAUTION**

**If grinding on valve face produces a valve with a thin edge, replace with a new valve.**

(f) Repair valves that can be refaced grinding to the requirements shown in figure 7-56.

(3) *Valve Seat.*

(a) Inspect valve seats. Reface valve seats if seat face is slightly pitted, burned, or worn and can be refaced to requirements in figure 7-56. If valve seats are loose, they must be replaced as follows:

(b) Secure valve seat remover cutter tool (fig. 7-57) in a drill press chuck and adjust tool to cut 1/64-inch from outside edge of valve seat.

(c) Apply oil to pilot end of cutting tool to prevent seizing in the valve guide (fig. 7-55).

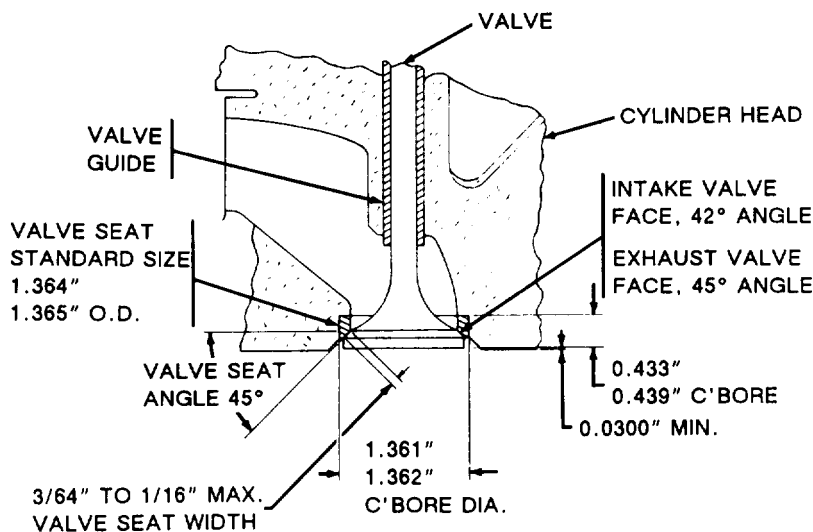

Figure 7-56. Valve Face and Valve Seat Grinding Requirements.

TA502330

**NOTE**

**If the counterbore is damaged, it must be machined for an oversized valve seat. Valve seats are available in 0.005- and 0.010-inch oversize diameters.**

(d) Cut valve seat to a narrow, 1/64-inch rind (fig. 7-57) and remove rind using a sharp tool. Do not damage valve seat counterbore.

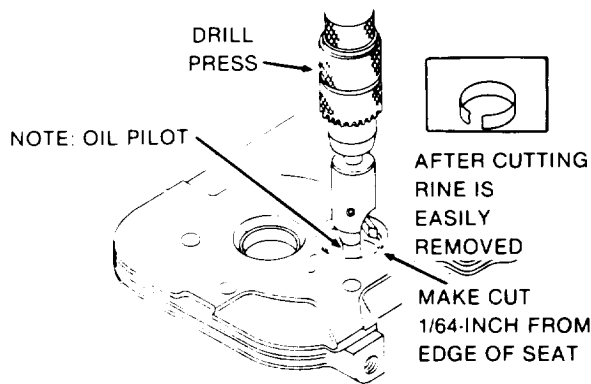

TA100128

**Figure 7-57, Removing Exhaust Valve Seat.**

(e) Clean out valve seat counterbore, remove burrs from edges, and check counterbore diameter (fig. 7-56).

**NOTE**

**To facilitate valve seat installation, heat the cylinder head in an oven at 325°F for approximately thirty minutes and cool the replacement valve seat in dry ice.**

(f) Install new replacement valve seat. Use the valve seat driver tool (table 5-1 and 14, fig. 7-55) to ensure that valve seat sets evenly in the counterbore.

(g) After installation, face each new valve seat to a 45° angle for exhaust valve and a 42° angle for intake valve, and a width of approximately 3/64- to 1/16-inch (fig. 7-56). The finished seat face should contact approximate center of valve face. Use Prussian Blue dye (item 12, Appendix E) on the valve face to check contact points with refaced valve seats. Make any corrections to the valve seat, not the valve face.

(h) Check for 0.0300-inch minimum clearance between valve head and cylinder head surface (fig. 7-56). If necessary, regrind valve seat.

(4) *Valve Spring.*

(a) Inspect valve spring (5, fig. 7-55) for evidence of damage. Replace spring if cracked, pitted, or if ends are out-of-square.

(b) Check valve spring for 1.875-inch free length.

(c) Inspect valve spring under load conditions using a compression scale as follows:

1. Compress spring to 1.528-inch (valve closed), and check scale for 45-49 lb. compression.

2. Compress spring to 1.182-inch (valve open), and check scale for 87-97 lb. compression.

(d) Discard springs that fail to meet above requirements.

d. *Assembly (Fig. 7-55).*

**NOTE**

**The valve stem seal assemblies (4) are installed on the Intake valve guides only.**

(1) Position a new replacement valve stem seal assembly (4, fig. 7-55) on the intake valve guides only. Apply a film of oil to inside surface of the valve stem seal.

(2) Apply a film of oil to the valve stem and insert valve stem up into the valve guide. Check valve for tight seal by making pencil marks at intervals on the valve face and observe if pencil marks rub off uniformly when valve is rotated 1/4 turn. If not a tight seal, regrind the valves.

(3) Using a valve spring compressor, compress the valve spring (5) and spring retainer (3) sufficiently to permit installation of the valve stem locks (2). Be certain the valve spring locks are properly seated before releasing the spring compressor.

(4) Repeat steps (1) through (3) to install remaining intake and exhaust valve components.

**7-73. Piston and Connecting Rod**

a. *Disassembly (Fig. 7-26).*

(1) Using ring expander, remove piston rings (1, 2, and 4, fig. 7-26) and oil ring expander (3) from each piston.

(2) Remove two retaining rings (5) and push piston pin (6) from each piston.

b. *Inspection and Repair.*

(1) **Pistons.** Thoroughly clean and inspect each piston. Clean carbon from ring grooves and ensure that all oil holes are open. If any piston is badly scored or buffed, loose in cylinders, has badly worn ring grooves, or otherwise is not in good condition, replace it. Check the piston clearance in cylinder 90° from axis of piston pin and below oil control fig (4, fig. 7-26). Clearance should be 0.0055- to 0.0075-inch. If not, replace piston and check cylinder wall for possible reconditioning.

**NOTE**

**Piston and pins are matched sets and are not procured separately.**

(2) *Piston Pins.* Each piston pin should be a thumb push fit into its piston at room temperatures. If pin is excessively loose, install a new piston and pin assembly.

(3) *Rings.* Place each piston ring into its cylinder bore and using a feeler gage, measure gap where indicated in figure 7-59. Gap is shown in table 7-2. If gap is under 0.010-inch, file as follows:

(a) Place file in vise.

(b) Grasp piston ring in both hands.

(c) Insert file into ring gap and move ring down the entire length of file. Be sure to apply equal pressure on the ring.

(4) *Connecting Rods (Fig. 7-58).* Clean connecting rods and check each for defects. Check connecting rod bushings for proper clearance with piston pin. Clearance is given in table 7-2. If bushings (13, fig. 7-26) are excessively worn, press them out and install one new bushing from each side of bushing bore. Press new bushings only until flush with sides of rod to leave 1/16-7/64-inch oil groove in center. Ream bushing I.D. to obtain the proper clearance. Check bore in connecting rod. Bore must be open. Check connecting rod alignment on a standard alignment fixture.

(5) *Connecting Rod Bearings (Fig. 7-26).* Inspect connecting rod bearings for burrs, breaks, pits, and wear. Measure clearance between bearings and crankshaft journal (table 7-2). If necessary, replace with new standard or under size precision bearings.

c. *Assembly (Fig. 7-26).*

**NOTE**

**The piston witness mark (notch) must face front of engine and rod witness marks (numbers) must face toward camshaft side of engine.**

(1) Install connecting rods (12, fig. 7-26) on each piston (7) with pins (6) and retaining rings (5). If new bushings (13) were installed, check to see that ends are flush with the connecting rod (12) to provide for oil passage in center (fig. 7-58).

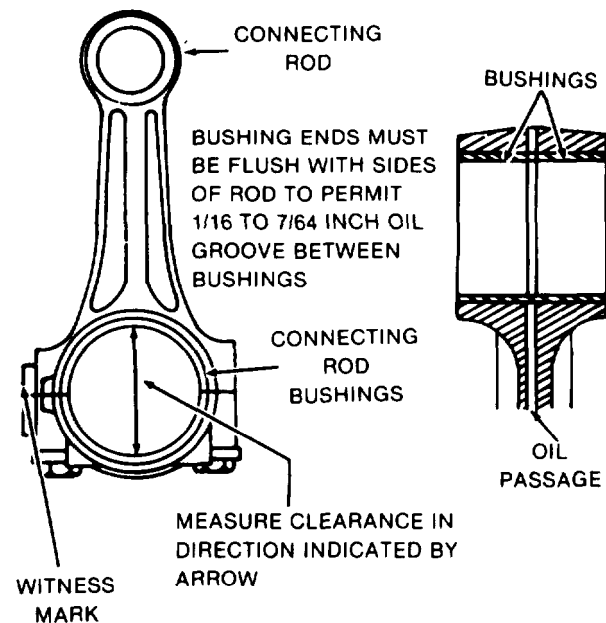

TA100129

**Figure 7-58. Connecting Rod and Bushings.**

(2) Refer to figure 7-59 and install rings and oil ring expander (1,2,3, and 4, fig. 7-26) on each piston (7). Compression rings will be marked TOP or identified in some other manner. Place this mark toward the closed end of piston. Space ring gaps 1/4 of the way around piston from one another. No gap should be in line with piston pin. Oil the rings (1,2, and 4) and pistons (7).

**NOTE**

**Ensure that rod bearings are installed in the same position they were in before they were removed.**

(3) Position a bearing half (11) in connecting rod (12) and cap (10). Be sure there is no dirt under bearing. This could cause high spots and early bearing failure.

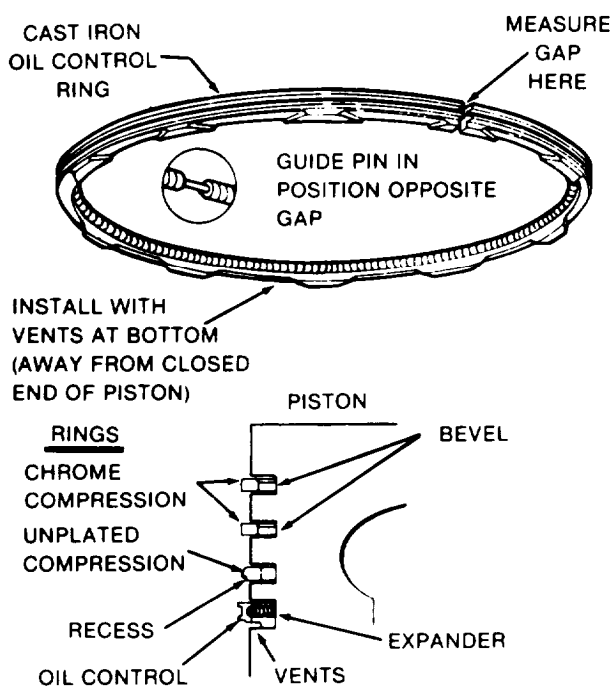

TA100130

Figure 7-59. Piston Ring Installation.

7-74. Oil Bypass Valve (Fig. 7-60)

a. Disassembly.

**CAUTION**

Use care when unscrewing recessed plug in rear bearing plate. Tension on the bypass spring may cause it to fly out.

(1) Unscrew recessed plug (1) in rear bearing plate (4).

(2) Lift out bypass spring (2) and valve plunger (3).

b. Cleaning.

**WARNING**

Dry cleaning solvent P-D-680 is toxic and flammable. Always wear protective goggles and gloves, and use Only in a well-ventilated area. Avoid contact with skin, eyes, and clothes, and DO NOT breathe vapors. DO NOT use near open flame or excessive heat. The solvent's flash point is 100°F-138°F (38°C-59°C). If you become dizzy while

using cleaning solvent, immediately get fresh air and medical help. If solvent contacts eyes, immediately wash your eyes with water and get medical aid.

(1) Clean oil bypass valve (3), spring (2), and plug (1), using dry cleaning solvent (item 11, Appendix E). Wipe dry using a clean, lint-free cloth (item 24, Appendix E).

(2) Flush oil port clean using clean diesel fuel (item 14, Appendix E). Wipe external surfaces dry using a clean, lint-free cloth (item 24, Appendix E).

**WARNING**

Particles blown by compressed air can be dangerous. Be certain to direct air stream away from the user and other personnel in the area.

(3) Air dry oil bypass valve port, using clean, filtered, compressed air under moderate pressure of approximately 15 psi.

- 1. Recessed plug
- 2. Bypass spring
- 3. Valve plunger
- 4. Rear bearing plate

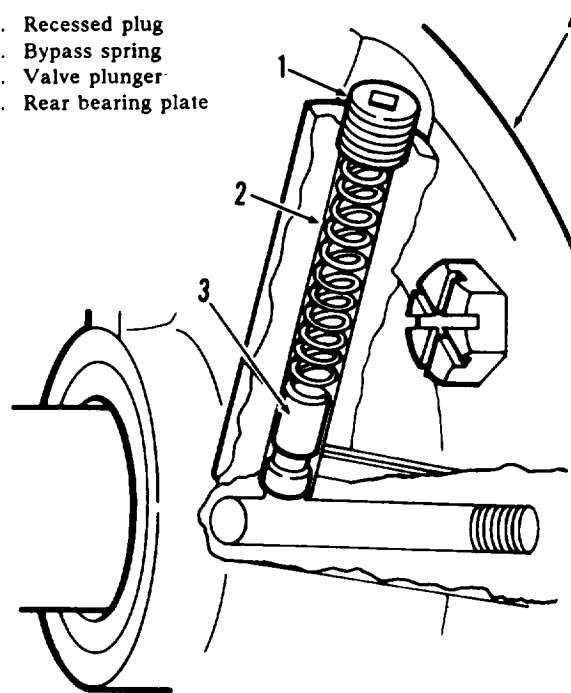

TA100131

Figure 7-60. Oil Bypass Valve-Disassembled.

(4) Soak all metal parts in a clean container containing hydraulic fluid (item 18, Appendix E). Wipe dry using a clean, lint-free cloth (item 24, Appendix E) and clean filtered air as in step (3) above.

(5) Coat all components with oil prior to assembly (para 7-62).

c. *Inspection and Repair.*

(1) Measure diameter of bypass valve (3). If measurement shows less than 0.3365-inch minimum diameter, replace valve. Maximum diameter should not exceed 0.3380-inch.

(2) Measure free length of valve spring (3). If free length is less than 2.3125-inch (+/- 0.0625-inch), replace valve spring.

(3) Inspect valve spring tension under load conditions. Using a compression scale, compress valve spring to 1.1875-inch, and check the scale for 2.225 lb. (+/- 0.110 lb.) compression.

(4) Inspect plug (1) for evidence of worn or damaged threads. Replace plug if defective.

d. *Assembly.*

(1) Assemble bypass spring (2, fig. 7-60) and valve plunger (3), and install in bearing plate (4).

(2) Install recessed plug (1). Tighten plug securely.

**7-75. Gear Cover Assembly**

a. *Disassembly (Fig. 7-28).*

(1) Remove external retaining ring (1, fig. 7-28) securing governor yoke (2) to the governor shaft (5), and remove the yoke (2).

(2) Slide governor shaft free of the gearcase.

**NOTE**

**Do not remove pressed-in components such as bearings, seals, and plugs unless there is evidence of damage, excessive wear or looseness.**

(3) Set the gearcase on wood supports.

(4) Using the combination main and cam bearing driver tool (table 5-1 and fig. 7-36) and the oil seal driver tool (table 5-1 and 13, fig. 7-28), drive out the oil seal (11).

(5) Using the valve guide driver tool (table 5-1), drive out the needle bearing (7) and oil seal (6).

(6) Remove thrust bearing (8) and ball (9) if defective.

b. *Cleaning.*

**WARNING**

**Dry cleaning solvent P-D-680 is toxic and flammable. Always wear protective goggles and gloves, and use only in a well-ventilated area. Avoid contact with skin, eyes, and clothes, and DO NOT breathe vapors. DO NOT use near open flame or excessive heat. The solvent's flash point is 100°F-138°F (38°C-59°C). If you become dizzy while using cleaning solvent, immediately get fresh air and medical help. If solvent contacts eyes, immediately wash your eyes with water and get medical aid.**

(1) Clean gearcase gasket mating surface using dry cleaning solvent (item 11, Appendix E). Ensure that mating surface is cleaned free of all excess gasket material. Wipe dry using a clean, lint-free cloth (item 24, Appendix E).

(2) Flush gearcase clean with diesel fuel (item 14, Appendix E) and clean out the oil passages using a fine cleaning wire.

**WARNING**

**Particles blown by compressed air can be dangerous. Ensure that air stream is directed away from the user and other personnel in the area.**

(3) Dry oil passages using clean, filtered compressed air under moderate pressure of approximately 15 psi.

c. *Inspection and Repair.*

(1) Visually inspect gearcase for nicks or dents on the gasket mating surface. Inspect for cracks. Inspect bolt holes for damaged or excessively worn threads. Replace gearcase if damaged.

(2) Inspect all components for evidence of excessive wear, scratches, and nicks. Replace defective components.

(3) Measure distance from end of roll pin to mounting face of gearcase. The distance should be 0.781-inch. If necessary to replace pin, the pin should be positioned with open end facing crankshaft seal.

d. *Assembly (Fig. 7-28).*

(1) Install thrust bearing (8, fig. 7-28) and ball (9), and press bearing into position.

(2) Install needle bearing (7) and oil seal (6) from outside of gearcase. Ensure that oil seal is flush with outside surface of gearcase.

(3) Join the oil seal loader and driver tool (13) together, and slide the oil seal (11) into position with lip toward the driver tool. Remove oil seal loader.

(4) Place the gearcase on a firm flat surface and install the oil seal flush with the gearcase outer surface.

(5) Install the governor shaft (5) and check shaft for binding.

(6) Install the governor yoke (2) on the shaft with smooth side toward the governor cup, and secure with external retaining ring (1).

e. *Test and Adjustment.*

(1) Work the governor shaft to check for binding.

(2) Coat all components with oil (para 7-62).

**7-76. Governor Cup (Fig. 7-30)**

a. Replace any flyballs that have flat spots or graves.

b. Replace cup if race surface is grooved or rough. The governor cup must be a free spinning fit on camshaft center pin, but should be replaced if excessively loose or wobbly.

c. Check distance the center pin extends from the camshaft gear. This distance must be 0.781-inch to give proper travel distance for the cup. If it is less, the engine may race; if more, the cup will not hold the balls properly.

d. If distance is too great, drive or press center pin in. If it is too small, replace pin; it cannot be removed without damaging the surface.

e. If aluminum ball spacer openings are badly worn, replace ball spacer (camshaft gear must be removed for this).

**7-77. Crankshaft**

a. *Cleaning and Inspection.*

(1) *Crankshaft.* Clean crankshaft and clear out all oil passages. Check journals for out-of-round, taper, grooving, or ridges. Pay particular attention to ridges or grooves on either side of oil hole areas. Unusual conditions here often point to previous neglect of oil changes. If journal dimensions are not within limits or journals are scored, metallize and regrind crankshaft to standards (table 7-2).

(2) *Bearings.* Replace bearings if clearances are greater than limits (table 7-2), or if bearings are worn, grooved, or broken.

(3) *Rear Oil Seal.* Inspect seal (17, fig. 7-27) for wear or damage which might cause it to leak. Use oil seal driver 420-0250 (table 5-1 and fig. 7-34) to install new seal.

b. *Rebuild Crankshaft.* If crankshaft requires regrinding, metallize and regrind to standards. Special procedures must be observed when reworking diesel crankshafts. In addition to regrinding, the crankshaft must be shot-peened and super-finished. Failure to shot-peen the crankpin fillets is likely to cause early failure. When the crankshaft is reground, follow this data and figure 7-61 to shot-peen each crankpin fillet.

(1) Peen with 0.019-inch diameter cast steel shot.

(2) Peen for 30 seconds on each crankpin fillet.

(3) Mask off connecting rod bearing arms.

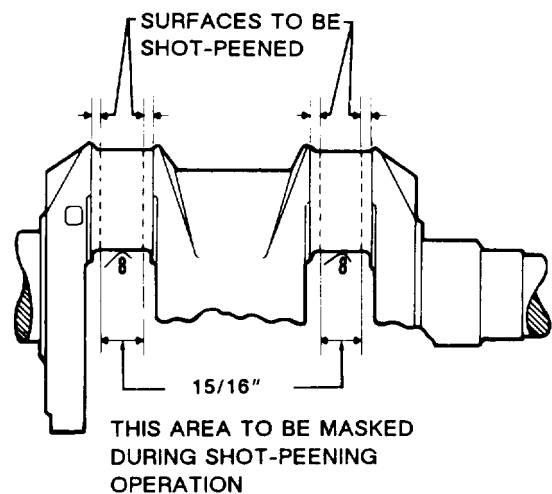

TA100132

**Figure 7-61. Crankshaft Peening.**

**7-78. Starter Assembly (Fig. 7-62)**

a. *Disassembly.*

(1) Remove nut (1) and lockwasher (2) from solenoid (9). Tag and remove lead (3). Disconnect connector and grommet (4).

(2) Remove cotter pin (5) and pin (6) from yoke (26). Remove screws (7), lockwashers (8), and remove solenoid switch (9).

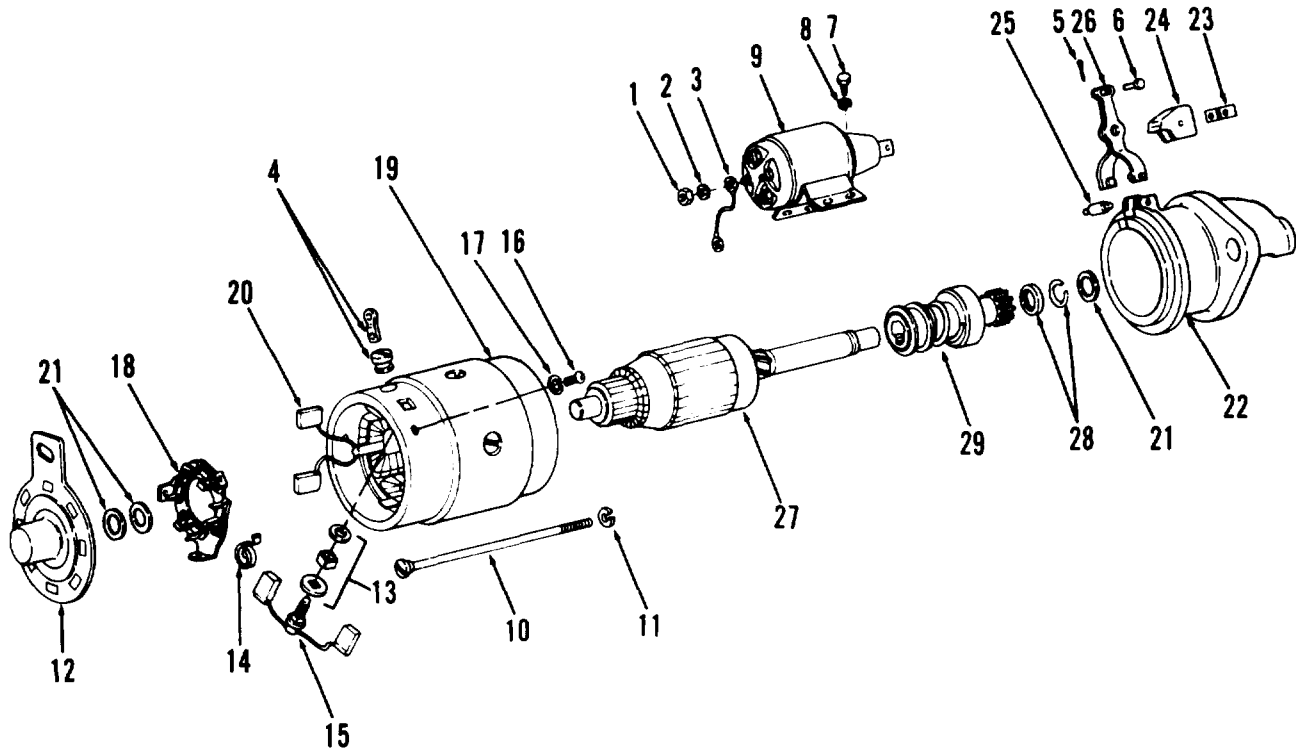

- |                          |                        |                        |
|--------------------------|------------------------|------------------------|
| 1. Nut                   | 11. Lockwasher (2)     | 21. Thrust washer (3)  |
| 2. Lockwasher            | 12. Backplate assembly | 22. Pinion housing     |
| 3. Lead                  | 13. Brush washer       | 23. Retainer           |
| 4. Connector and grommet | 14. Brush spring (4)   | 24. Boot               |
| 5. Cotter pin            | 15. Brush assembly     | 25. Pin                |
| 6. Pin                   | 16. Screw (3)          | 26. Yoke               |
| 7. Screw (4)             | 17. Lockwasher (3)     | 27. Armature           |
| 8. Lockwasher (4)        | 18. Brush holder       | 28. Lock ring and stop |
| 9. Solenoid switch       | 19. Frame assembly     | 29. Drive assembly     |
| 10. Thru bolt (2)        | 20. Brush assembly     |                        |

TA502331

**Figure 7-62. Electric Starter Assembly.**

(3) Remove through bolts (10) and lockwashers (11), and remove backplate assembly (12) and thrust washers (21). Remove nuts and washers (13) from brush assembly (15). Raise brush spring (14), and lift brushes (15) from brush holder. Remove screws (16) and lockwashers (17), and remove brush holder (18). Raise springs (14) and lift other brushes from brush holder. Remove springs (14) from brush holder.

(4) Remove retainer (23), boot (24), and pin (25). Separate pinion housing (22) and frame assembly (19). Do not lose thrust washer (21). Remove other set of brushes (20) by cutting leads 1-inch on each side of welded connection (fig. 7-63).

(5) Remove yoke (26), and remove armature (27) and drive assembly (29). Remove lock ring and stop (28) by pressing stop toward armature until lock ring becomes

accessible. Remove lock ring (28) and drive assembly (29) from armature (27). Do not disassemble drive assembly.

b. *Cleaning and Inspection.*

**WARNING**

- **Dry cleaning solvent P-D-680 is toxic and flammable. Always wear protective goggles and gloves, and use only in a well-ventilated area. Avoid contact with skin, eyes, and clothes, and DO NOT breathe vapors. DO NOT use near open flame or excessive heat. The solvent's flash point is 100°F-138°F (38°C-59°C). If you become dizzy while using cleaning solvent, immediately get fresh air and medical help. If solvent contacts eyes,**



**Immediately wash your eyes with water and get medical aid.**

- **Particles blown by compressed air can be dangerous. Be sure to direct air stream away from the user and other personnel in the area.**

**CAUTION**

- **Do not saturate armature or field coils with solvent as wire insulation may be damaged. Do not dip drive assembly in solvent as it is packed in grease and cannot be replaced.**
- **Never use emery cloth to clean commutator.**

(1) *Cleaning.* Clean dust off parts with compressed air or soft brush. Remove grease and oil with dry cleaning solvent (item 11, Appendix E). Remove discoloration or oxidation from commutator with fine sandpaper grade 00. Clean off sand with compressed air. Use only sandpaper.

(2) *Bearings.* Inspect bearing in pinion housing for wear. Replace pinion housing (22) if bearing is excessively worn. Inspect bearing in backplate assembly (12). If excessively worn, replace backplate assembly.

(3) *Drive Assembly.* Inspect starter drive (29) for cracks or chipped teeth. Ensure that shaft and spring under drive moves freely and returns to rear position when released.

(4) *Brushes.* Lift brush tension springs (14) and lift each brush (20) from holder for inspection. Check

brush face for deep surface pits, cracks, or chipping. Measure brush length. When brush is worn to less than X-inch, replace. Clean the area around brushes and commutator with dry, low pressure compressed air.

(5) *Solenoid Switch.* Inspect solenoid switch (9) for cracks, dents, or other damage. Ensure that electrical terminals are clean and free of corrosion. Check that the rubber boot on the plunger and yoke is in good condition. After installation, ensure that plunger and yoke move freely.

(6) *Armature.* Inspect armature (27) for wear. Inspect commutator for wear. If worn, replace starter.

(7) *Yoke.* Inspect yoke (26) for damage or wear.

(8) *Frame Assembly.* Inspect frame assembly (19) for damage. If frame assembly is bad, replace starter.

c. Assembly.

(1) Slide drive assembly (29) onto shaft of armature (27). Install stop and lock ring (28) on end of the armature shaft (27).

(2) Install thrust washer (21) on the end of the armature shaft (27). Slip yoke (26) onto drive assembly (29), and install both in pinion housing (22). Install pin (25) in pinion housing (22) to hold yoke (26) in place.

(3) If brushes (20) are excessively worn, cut brush leads 1-inch from the welded connection (fig. 7-63). Install new brushes as follows:

(a) Using rosin core solder and soldering iron, or heavy duty soldering gun, tin the remaining sections of the original brush lead.

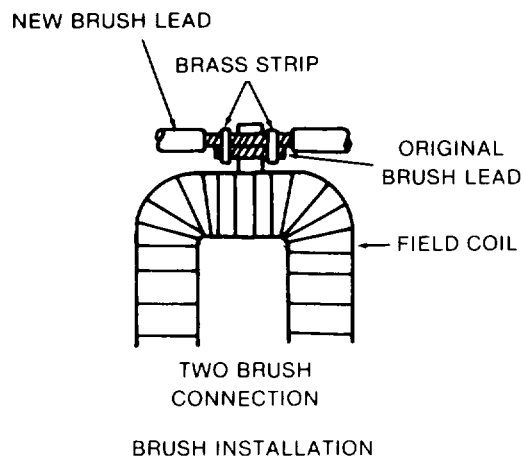
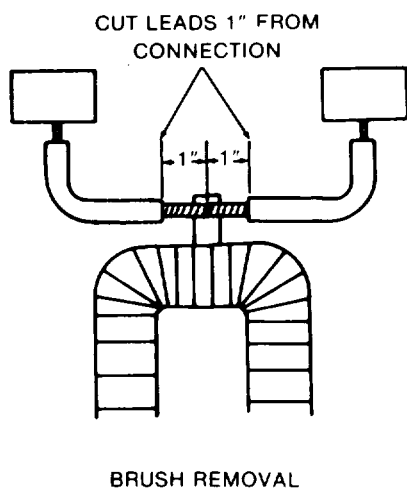

Figure 7-63. Brush Replacement,

TA100134

(b) Position the new brush lead next to the tinned sections of the original brush lead. Install and crimp the brass strip connectors (included) around both leads to hold the new brushes in place (fig. 7-63).

(c) Solder the new brushes in place. Position the brush leads so they do not contact the frame or interfere with through bolt installation.

(4) Install brush assembly (15, fig. 7-62) and brush washers (13) in frame assembly (19), and install previously removed lockwasher and nut on stud of brush assembly (15).

(5) Install brushes (15 and 20) in brush holder (18). Attach brush holder (18) to frame assembly (19) with screws (16) and lockwashers (17).

(6) Assemble armature (27), drive assembly (29), and pinion housing (22) with frame assembly (19).

(7) Install brush springs (14).

(8) Install thrust washers (21) on the end of the armature shaft (27) and install backplate assembly (12) on the frame assembly (19) with through bolts (10) and lockwashers (11).

(9) Install solenoid switch (9) on frame assembly (19) with screws (7) and lockwashers (8) so that bottom terminal of solenoid (9) goes through connector (4). Attach terminal to connector with hardware on the solenoid switch (9). Connect plunger of solenoid (9) and yoke (26) with pin (6). Retain pin (6) with cotter pin (5). Install boot (24) and retainer (23) over yoke (26). Check that plunger and yoke move freely when solenoid switch is securely fastened to starting motor.

(10) Connect tagged lead (3) between solenoid switch (9) and brush assembly (15). Install nut (1) and lockwasher (2). Remove tags.

### 7-79. Alternator (Fig. 7-64)

#### a. *Disassembly.*

(1) Hold the pulley of the alternator in a vise with soft jaws and remove pulley nut (1, fig. 7-64). Use a suitable puller and remove pulley (2) and fan (3).

(2) Using a brass drift and hammer, remove woodruff key (11) from keyway in rotor shaft. Remove spacer (4).

(3) Remove four screws which fasten regulator (43) in housing (37). Lift regulator from housing and disconnect red and black leads from regulator. Tag the position of the leads for correct assembly.

(4) Remove lead from diode trio (42) to terminal on regulator housing (37). Loosen the inner nut (34) and pull blue wire (35) from under head of terminal screw. Remove the regulator (43).

(5) Lift the brush and spring assemblies (44) from the regulator housing (37).

(6) Remove three nuts and lift diode trio (42) from AC terminal studs (fig. 7-65).

(7) Remove three self-locking nuts (32, fig. 7-64), through bolts (5), and washers (6). Carefully separate the rotor (12) and drive end housing (7) from the stator (14) and slip ring end housing (31). See figure 7-66 for typical disassembly. If drive end housing binds on stator, loosen by tapping with a soft hammer. Ensure that drive end housing separates from stator and that stator remains attached to slip ring end housing to avoid damage to stator leads.

(8) Remove three nuts (fig. 7-67) which secure stator leads to terminals and remove stator from slip ring end housing.

(9) Remove two nuts (40), washers (39), and nuts (38) from positive and negative output terminal bolts (19 and 20). Remove terminal bolts (19 and 20). Tag the location of the red and black regulator leads on the heat sinks.

(10) Remove regulator housing (37). Note the location of gasket (36) which seals the brush compartment.

(11) Remove three screws (23, fig. 7-64), clamp (24), and capacitor (25) connected between the heat sinks (21 and 22).

(12) Remove two capscrews (15), lockwashers (16), and guard washers (17) which retain lower end of heat sinks (21 and 22). Remove heat sinks, and remove insulating bushings (26) from heat sinks.

(13) Remove terminal stud insulating bushings (27, 28, 29, and 30) from slip ring end housing (31). There are two bushings in each terminal hole.

(14) Remove slip ring end bearing (13) only if replacement is necessary. Pry flanged dust cap (33) out of slip ring end housing (31). Press bearing from the inside of the housing outward.

(15) If bearing (8) must be replaced, use a puller to remove the drive end housing (7) and bearing assembly (8, 9, and 10) from the rotor shaft.

(16) Remove four screws (10) and bearing retainer (9), and press bearing (8) out of drive end housing.

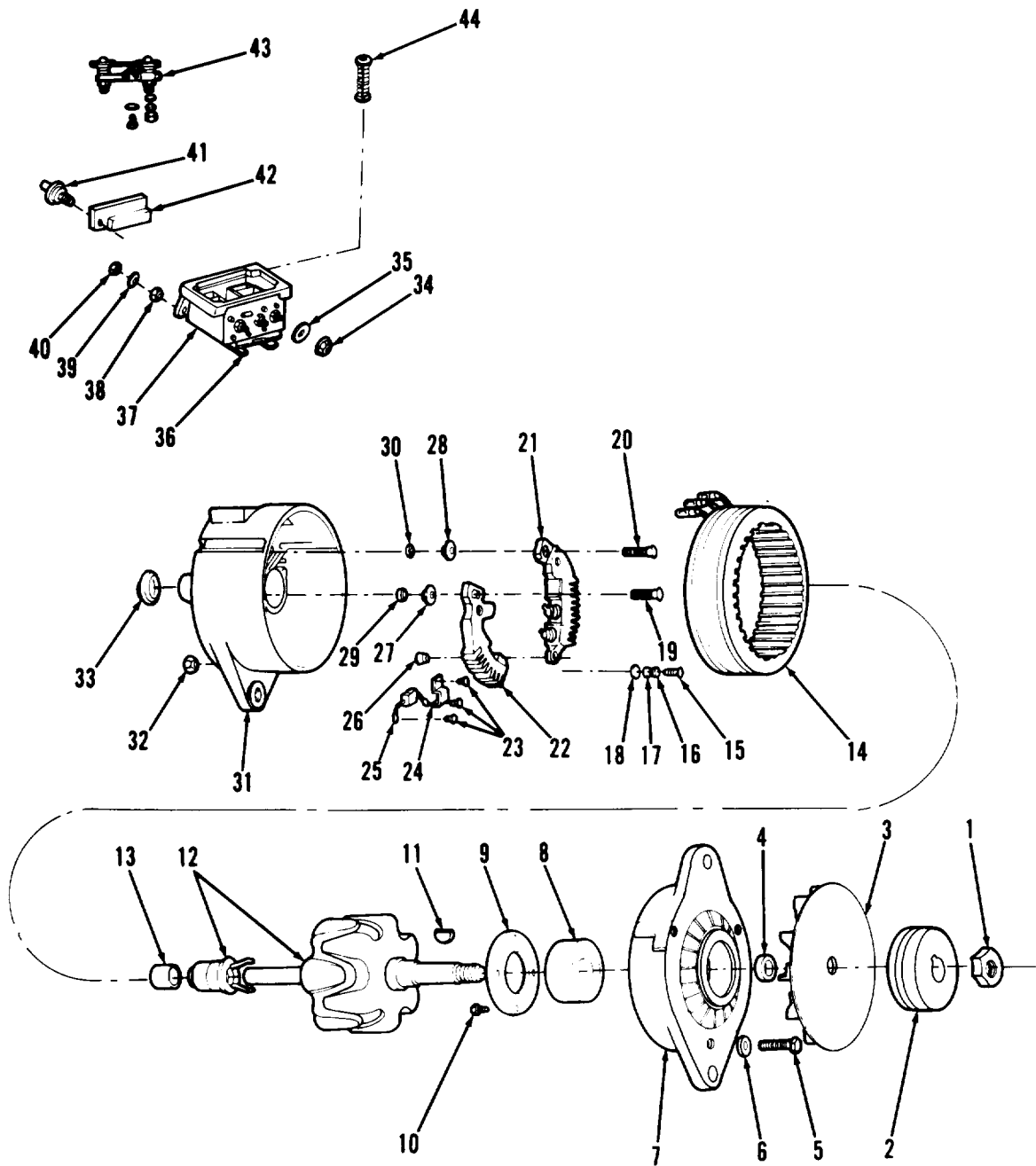

- |                      |                                  |                            |                        |
|----------------------|----------------------------------|----------------------------|------------------------|
| 1. Nut               | 12. Rotor and slip ring assembly | 23. Screw (2)              | 34. Nut                |
| 2. Pulley            | 13. Bearing                      | 24. Clamp                  | 35. Blue wire          |
| 3. Fan               | 14. Stator                       | 25. Capacitor              | 36. Gasket             |
| 4. Spacer            | 15. Screw (2)                    | 26. Insulation bushing (2) | 37. Regulator housing  |
| 5. Bolt (3)          | 16. Lockwasher (2)               | 27. Insulation bushing     | 38. Nut (2)            |
| 6. Washer (3)        | 17. Guard washer (2)             | 28. Insulation bushing     | 39. Washer (2)         |
| 7. Housing drive end | 18. Insulated washer (2)         | 29. Insulation bushing     | 40. Nut (2)            |
| 8. Bearing           | 19. Terminal screw (+)           | 30. Insulation bushing     | 41. Terminal screw (5) |
| 9. Bearing retainer  | 20. Terminal screw (-)           | 31. Housing, slip ring end | 42. Diode trio         |
| 10. Screw (4)        | 21. Heat sink (+)                | 32. Nut (3)                | 43. Regulator assembly |
| 11. Woodruff key     | 22. Heat sink (-)                | 33. Dust cap               | 44. Brush and spring   |

TA502332

Figure 7-64. Alternator Assembly.

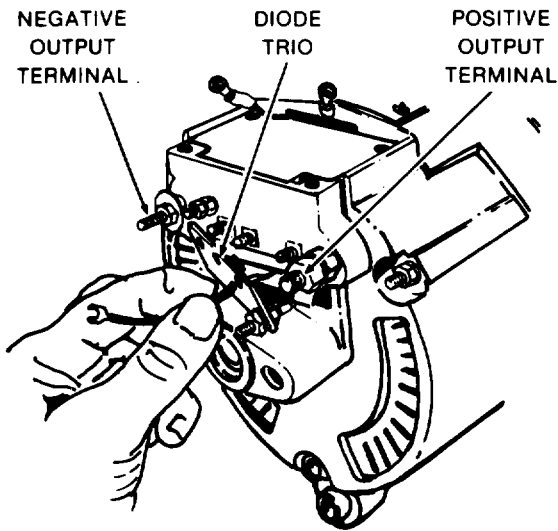

TA100136

Figure 7-65. Removing Diode Trio.

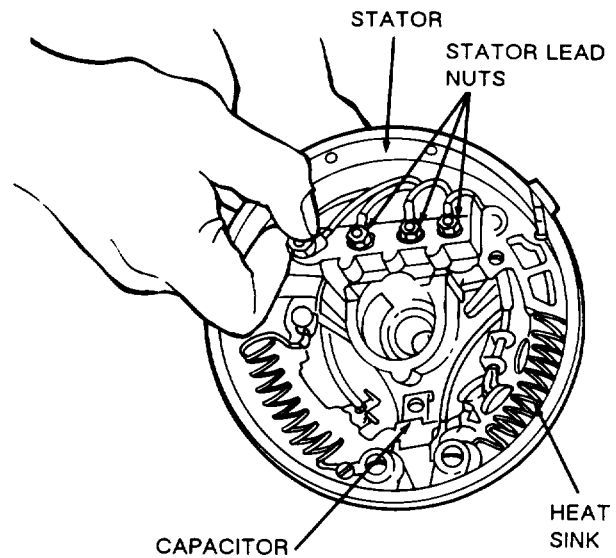

TA502333

Figure 7-67. Removing Stator

b. *Cleaning and Inspection.*

**WARNING**

**Particles blown by compressed air can be dangerous. Be sure to direct air stream away from the user and other personnel in the area.**

- (1) Use low pressure, moisture-free compressed air to remove dust and residue.
- (2) Carefully inspect all parts for wear, cracks, breakage, or other defects.
- (3) Rotate bearings by hand and check for binding or wear.

c. *Assembly.*

(1) If slip ring end bearing (13, fig. 7-64) has been removed, press a new bearing in place from the outside of the slip ring end housing (31). Bearing should be installed with seal facing in toward the slip rings. When properly installed, the manufacturer's part number stamped on the end of the bearing will be facing toward the outside of the housing. Bearing should seat against lip on inside end of bearing bore. After bearing is installed, apply a small amount of SRI 2 grease to rollers.

(2) Install insulating bushings (27, 28, 29, and 30, fig. 7-64) into slip ring end housing (fig. 7-68).

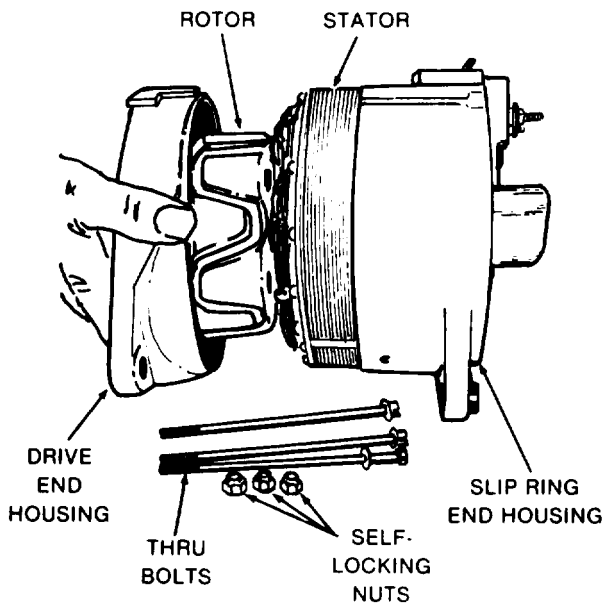

TA100137

Figure 7-66. Dismantling Alternator.

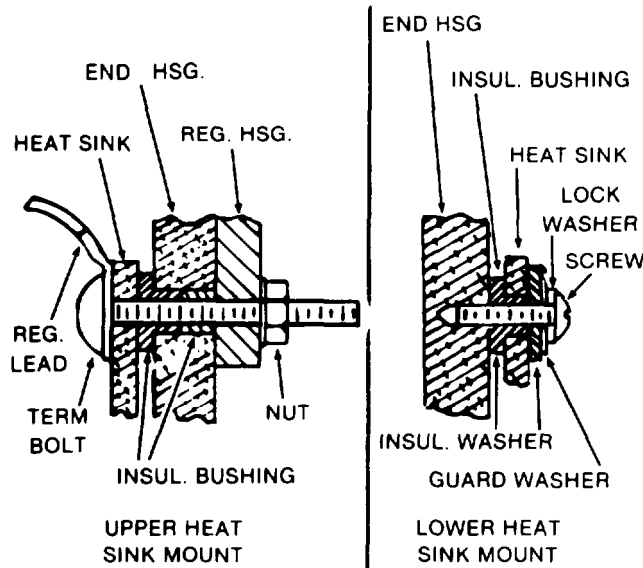

TA100139

Figure 7-68. Heat Sink Mounting.

(3) Install insulating bushings (26) into heat sinks (21 and 22). Position heat sinks in the slip ring end housing (31) and fasten with two capscrews (15), lockwashers (16), guard washers (17), and insulating washers (18). Do not tighten (fig. 7-68).

(4) Install capacitor (25), clamp (24), and three screws (23).

(5) Replace the gasket (36) and regulator housing (37).

**NOTE**

**Be sure mating surfaces of heat sinks, terminals, and terminal screws are clean and free of paint to ensure a good electrical connection.**

(6) Install the regulator lead wires to the terminal bolts. Red wire goes on the positive terminal screw (19), and black wire goes on negative terminal screw (20).

(7) Install terminal bolts through heat sinks, slip ring end housing (31), and regulator housing (37). Ensure that red and black regulator leads (fig. 7-69) are properly routed through cutaway section of end housing (31).

(8) Install two nuts (38) on terminal screws (19 and 20). Tighten nuts. Loosely install two washers (39) and nuts (40).

(9) Tighten lower heat sink screws (15) and check all leads for proper routing. Ensure that no lead is pinched under heat sink.

(10) Reinstall stator and terminal nuts. It is advisable to align stator (14) and housing (31) by temporarily installing the through bolts (5).

(11) Press drive end bearing (8) into housing (7), and reinstall bearing retainer (9) and four screws (10).

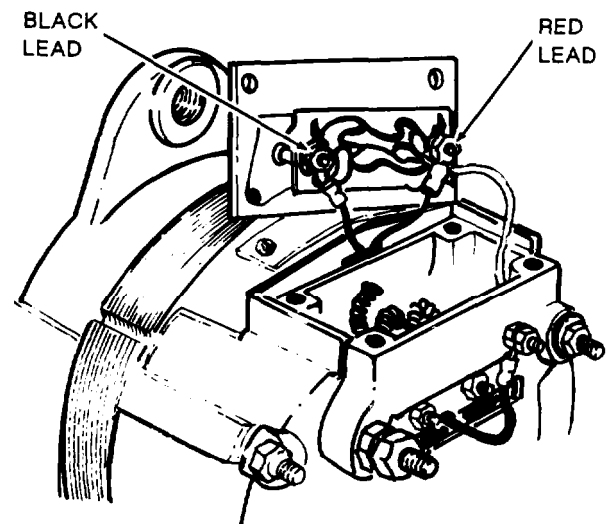

TA100140

Figure 7-69. Installing Regulator Leads.

(12) Press drive end housing (7) and bearing (8) onto rotor shaft.

(13) Install rotor (12) and housing (7) assembly into stator (14) and slip ring end housing (31) assembly, being sure to align mounting ears.

(14) Install three through bolts (5), washers (6), and self-locking nuts (32). Tighten nuts to 50-60 lb.-in. Place a small amount of SRI 2 grease in housing and reinstall the metal dust cap (33) by carefully pressing it into place.

(15) Install diode trio and three nuts (fig. 7-65).

(16) Insert outer brush and spring assembly (44) into the housing (37), and compress the brush spring. Use a small screwdriver or similar tool. While holding the spring compressed, insert a pin through the hole in the rear of the housing so the spring will be held in a compressed position. (A suitable pin can be made from a piece of 1/16-inch drill rod.) Install and compress the remaining brush and spring assembly (44) in a similar manner. Hold the spring in a compressed position by pushing the pin farther into the housing (fig. 7-70).

(17) Attach red and black leads (fig. 7-69) to regulator (43, fig. 7-64). Attach blue regulator lead to diode terminal screw by placing the spade terminal under the head of the screw. Tighten nut on terminal screw (fig. 7-64). Install regulator, and ensure that the red and black leads are properly routed through their slots in the regulator housing (37, fig. 7-64). Install the four screws to fasten regulator in housing. Remove brush retaining pin before tightening the screws.

(18) Install diode trio lead and nut.

**NOTE**

**Due to the design of the alternator, a certain amount of shaft end play will be present in new or rebuilt units. This end play is designed into the unit and will vary between .004- and .012-inch.**

(19) Install spacer (4), key (11), fan (3), pulley (2), and nut (1). Tighten nut to 70-80 lb.-ft.

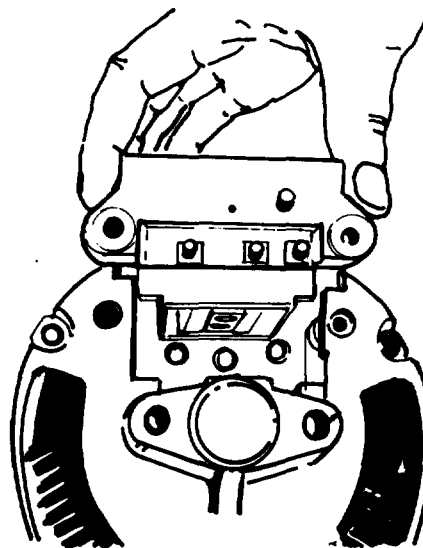

TA100141

Figure 7-70. Installing Brush Assemblies.

**Section IV. TEST AND ADJUSTMENTS**

**7-80. General**

a. This section contains the test and adjustment procedures that are required to be performed on a rebuilt or repaired engine. These tests must be performed with engine installed on semitrailer, and with batteries, control boxes, fuel supply filters, and electrical supply hooked up to the engine.

**WARNING**

**Carbon monoxide is a colorless, odorless, and deadly poisonous gas which occurs in the exhaust fumes of the auxillary power engine. Exposure to air contaminated with carbon monoxide produces symptoms of headache, dizziness, loss of muscular control, apparent drowsiness, and coma. Permanent brain damage or death can result from severe exposure to carbon monoxide gas.**

b. Engine must be properly vented to exhaust the engine to outside air. If possible, avoid sharp bends in

exhaust pipe or use sweeping, large radius elbows. Use a section of seamless, flexible tubing between the engine and any rigid pipe to restrict vibration. Increase exhaust pipe one size larger for each additional 10 feet of length.

c. For engine operating instructions, refer to paragraph 2-10.

**7-81. Air Shutter Test and Adjustment**

a. *Thermo Power Unit Assembly Test.* Immerse the thermo unit (26, fig. 7-44) into a container of oil while monitoring the oil temperature. Plunger of thermo unit should start to extend when temperature reaches 120°F. Total extension at 140°F should be at least 13/64-inch. Replace thermo unit if it does not operate properly.

b. *Adjustments.*

(1) *Shutters (Fig. 7-71).* Disconnect ball joint from upper shutter. Adjust ball joint until upper shutter closes tightly on lower shutter when lower shutter is held closed. Reattach ball joint to upper shutter.

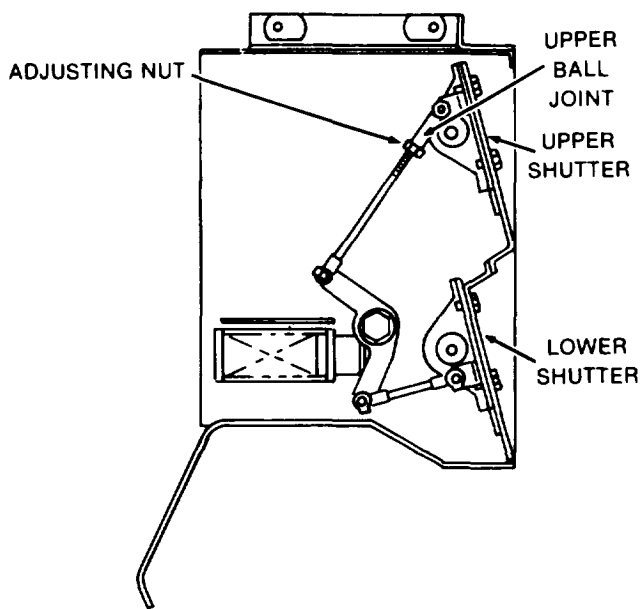

TA100142

Figure 7-71. Adjusting Shutters.

(2) Thermo Unit (Fig. 7-72). With engine at room temperature, loosen thermo unit guide mounting screws. The mounting holes in the shutter box are slotted. Slide the assembly to a position where the thermo unit plunger rests on roll pins with shutters closed. Tighten mounting screws.

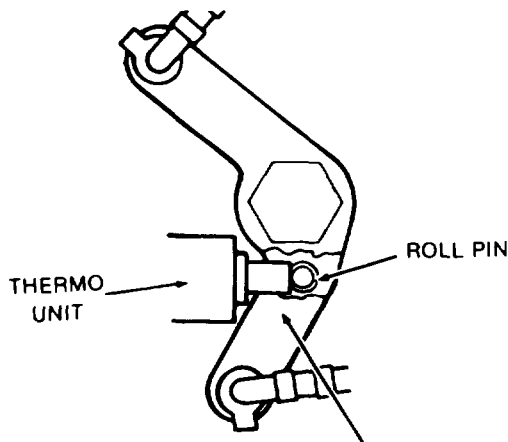

ADJUST THERMO UNIT TO REST ON ROLL PIN WITH SHUTTER CLOSED AT AMBIENT TEMPERATURE (APPROX 70° F [21° C] COLD ENGINE)

TA100143

Figure 7-72. Adjusting Thermo Unit.

**7-82. Tachometer Recalibration**

- a. Remove six screws which secure the instrument panel and tilt the panel outward for access to the back of the tachometer (fig. 4-39).
- b. Start engine. Use a stroboscope and flash on engine-pump coupling. Increase engine speed until stroboscope reads 2000 rpm.
- c. Using a small screwdriver, turn adjusting screw on tachometer (fig. 7-73) until the tachometer reads 2000 rpm.
- d. Release throttle and stop engine.
- e. Close the instrument panel and fasten with six screws.

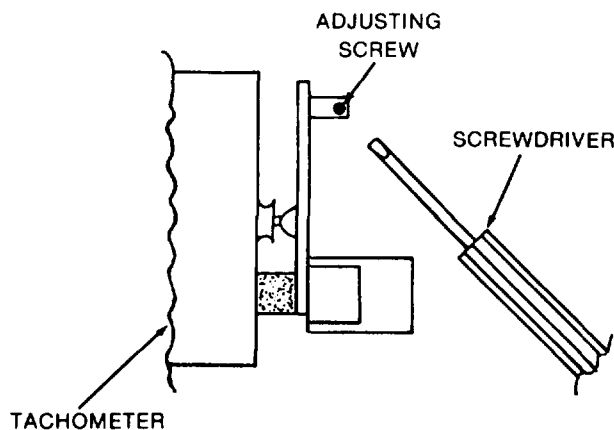

TA100144

Figure 7-73. Tachometer Calibration.

**7-83. High Temperature Switch Test**

Refer to paragraph 4-23 for proper test procedures.

**7-84. Governor Speed and Sensitivity Adjustment**

Refer to paragraph 4-76 for proper adjustment procedures.

**7-85. Fuel Stop Solenoid Adjustment (Fig. 7-16)**

- a. The solenoid plunger should be adjusted so it fully stops injection when in the de-energized position.
- b. To adjust the plunger length, turn the adjusting screw and jamnut on the plunger bottom in or out.
- c. If the plunger sticks, remove the fuel stop solenoid from its mounting plate (para 7-20). Clean the plunger and recess in the solenoid.

## 7-86. Fuel Injection Pump

### a. Test, After Rebuilding.

(1) Turn pump upside down and depress tappet with thumb. Tappet should recede 1/16-inch into face gear (fig. 7-74). If tappet cannot be depressed 1/16-inch into face gear, plunger sleeve pin (5, fig. 7-46) is improperly aligned. Disassemble pump and re-align pin (para 7-69).

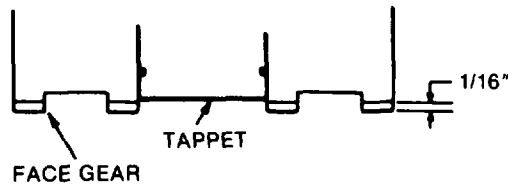

TA100145

Figure 7-74. Checking Plunger Sleeve Alinement.

(2) Remove the overflow valve assembly from the fuel outlet hole in the pump housing. Install a 1/4-inch pipe plug (fig. 7-75) into the fuel outlet hole.

(3) Secure the pump close to a nozzle test stand.

(4) Cap outlet ports (fig. 7-75).

(5) Install C-clamp on injection pumps to retain face gear (fig. 7-75).

(6) Aline holes in face gear and housing (fig. 7-75).

### NOTE

**A fuel inlet stud can be fabricated with a 1/4-18 NPT pipe die. High pressure tubing must be used between test stand and the pump assembly. Always ensure that all external connections are tight and that the nozzle test stand is in good order.**

(7) Connect the nozzle test stand to the fuel inlet hole in the pump housing.

### CAUTION

**Do not exceed a pressure of 400 psi.**

(8) Slowly operate the nozzle test stand until a pressure of 400 psi is achieved. A rapid drop in pressure

indicates that a leak is present. The pressure must remain above 250 psi for at least 30 seconds.

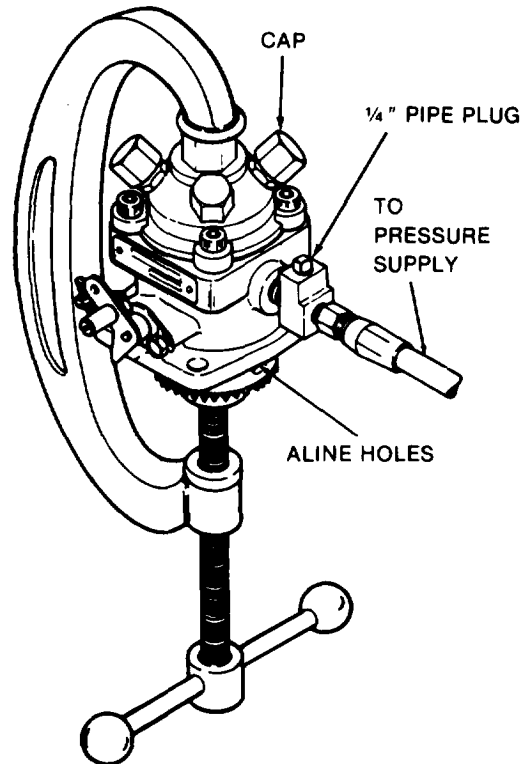

TA100146

Figure 7-75. Pressure Testing Injection Pump.

(9) Visual inspection should be as follows:

(a) Check for leakage by the head locating screw (13, 7-46).

(b) Fuel leakage at the control unit (4) indicates that either the O-ring (33) is damaged or the control unit is defective. Replace entire injection pump.

(c) Check for leakage of fuel around the face gear (28). If leakage is evident, disassemble pump and inspect O-ring (19). If O-ring is damaged, replace injection pump.

(d) Check for fuel leakage between top of housing and head flange. Disassemble and check O-ring. If O-ring is damaged, replace injection pump.

### b. On Equipment Adjustment and Timing.

(1) *Timing.* Time the injection pump to the engine by using the proper thickness timing button between the pump plunger and tappet (fig. 7-76). Use method 1 when replacing an old pump if the port closing dimensions and button number of the old pump were recorded. Use method 2 if the dimensions are lost; an old pump is being timed, or when replacing either camshaft or crankshaft.



(2) *Timing Method 1.* This is a means for calculating the correct button thickness before the pump is installed. It requires the port closing dimensions and button thickness from the pump being replaced. Substitute the dimensions for those in the formula below and calculate the new button thickness. Determine the button code letter from table 7-4.

**Example Formula:**

Port closing dimension of old pump  
 (removed from engine) . . . . . 1.109  
 Button thickness of old pump . . . . . + 0.107  
 . . . . . 1.216  
 Port closing dimension of new pump . . . . . - 1.103  
 Button thickness of new pump . . . . . 0.113  
 Use button C

**NOTE**

**Always use button thickness closest to this dimension.**

**Table 7-4. Button Code Letter and Size.**

No.	Code Or Letter	Part No	Size
16	S	147-0186	0.134
15	R	147-0187	0.131
14	P	147-0188	0.128
13	N	147-0189	0.125
12	M	147-0190	0.122
1	A	147-0147	0.119
2	B	147-0148	0.116
3	c	147-0149	0.113
4	D	147-0150	0.110
5	E	147-0151	0.107
11	None	147-0161	0.104
6	F	147-0152	0.101
7	H	147-0153	0.098
8	J	147-0154	0.095
9	K	147-0155	0.092
10	L	147-0158	0.089

Install the correct button in pump (fig. 7-76). Install pump (para 7-48).

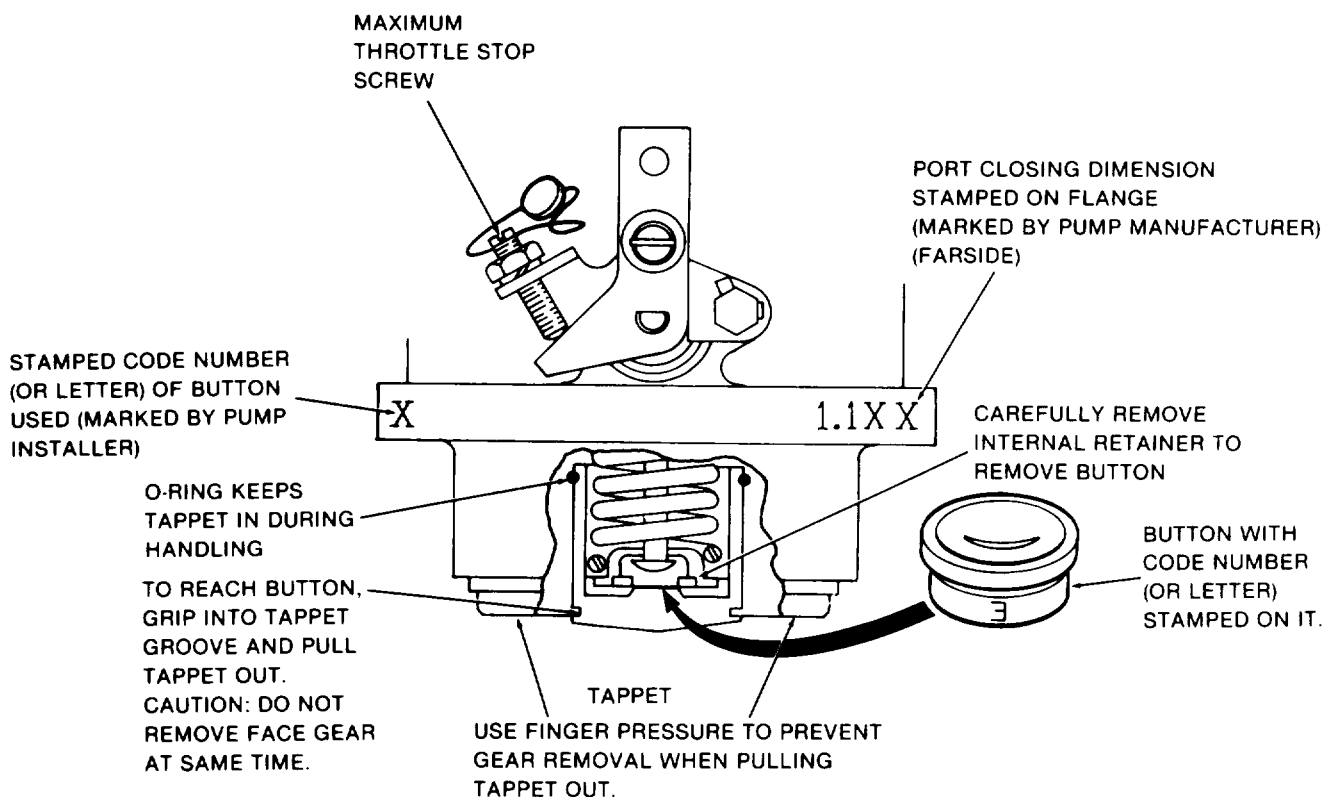

**Figure 7-76. Injection Pump Adjustment and Button Removal.**

TA100147

(3) Timing *Method 2*. Flow Timing the Pump.

**CAUTION**

**When removing tappets which contain timing buttons, do not allow the portion of the injection pump which has the face gear to be lifted from its position.**

(a) Install a Number 11 or standard timing button in injection pump. Install pump on engine (para 7-48).

(b) Remove delivery valve cap nut and delivery valve holder (fig. 7-77). A 12-point socket or box wrench must be used on delivery valve holder to keep from damaging this part. Lift out delivery valve spring only, and leave it out, replacing delivery valve holder and delivery valve cap nut and gasket.

(c) Turn flywheel (fig. 7-78) clockwise until Number 1 cylinder (closest to blower wheel) is on compression stroke, which follows closing of intake valve.

(d) Set control unit lever on injection pump to wide open or up position (compress stop solenoid plunger spring or remove stop solenoid assembly). Connect Number 1 cylinder fuel line to Number 1 pump outlet so that fuel line projects from the engine, hanging down (fig. 7-15). Position receptacle for fuel under the line. Connect lines from fuel supply to transfer pumps, transfer pumps to filter, and filter to injection pump. Operate fuel transfer pumps to obtain fuel pressure at

injection pump. This can be done on the unit by turning engine switch to RUN. Rotate flywheel about 1-inch counterclockwise so that P.C. mark (fig. 7-78) is below timing pointer hole.

(e) Rotate blower flywheel clockwise until fuel flows from Number 1 cylinder fuel line. Continue rotating slowly clockwise until fuel stops flowing. The point at which fuel stops flowing from Number 1 cylinder fuel delivery line is the injection pump port closing point. Stop rotation of engine at exactly the port closing point (1 to 2 drops in 5-10 seconds).

(f) Check timing pointer in the timing port on the side of the generator adapter (fig. 7-78). If timing pointer coincides with the P.C. mark stamped on flywheel, the injection pump button thickness is correct. If the P.C. mark on the flywheel is below the pointer, injection pump is closing early, and will require a thinner button. If the P.C. mark on flywheel is above the pointer, injection pump is closing late and will require a thicker button. Each mark on flywheel indicates a difference of 0.006-inch button thickness or two steps in button code number. (Example: The P.C. mark on flywheel is above pointer. The pointer indicates 1½ marks difference. A button 0.009-inch thicker or three steps difference in button number code is indicated. Since Number 11 button is installed, a letter C button is needed.)

(g) Remove injection pump and insert proper timing button, taking the same precautions not to lift the assembly containing face gear when removing timing button.

(h) Repeat injection pump installation.

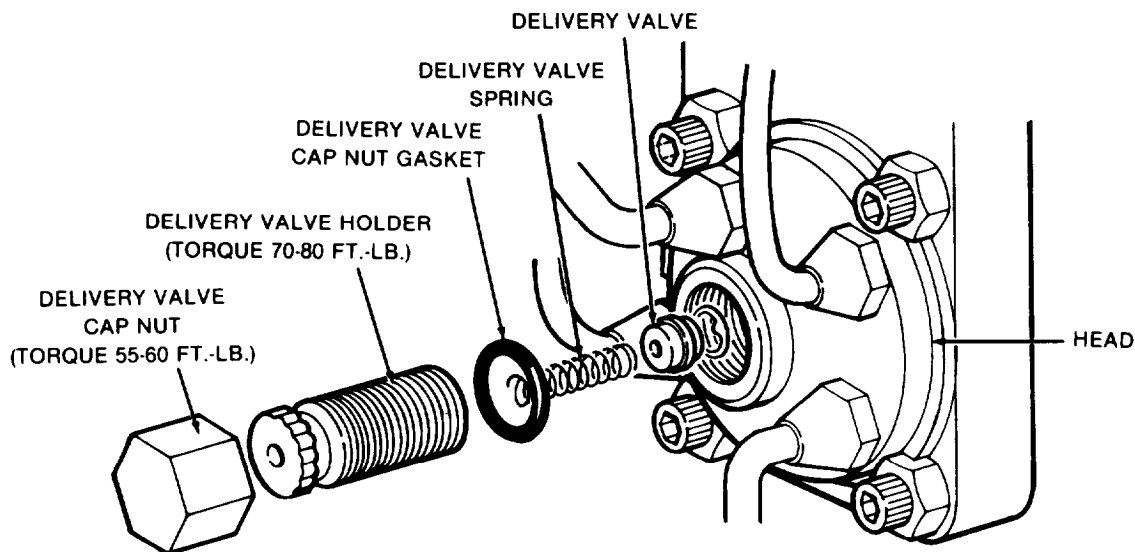

Figure 7-77. Delivery Valve.

TA100148

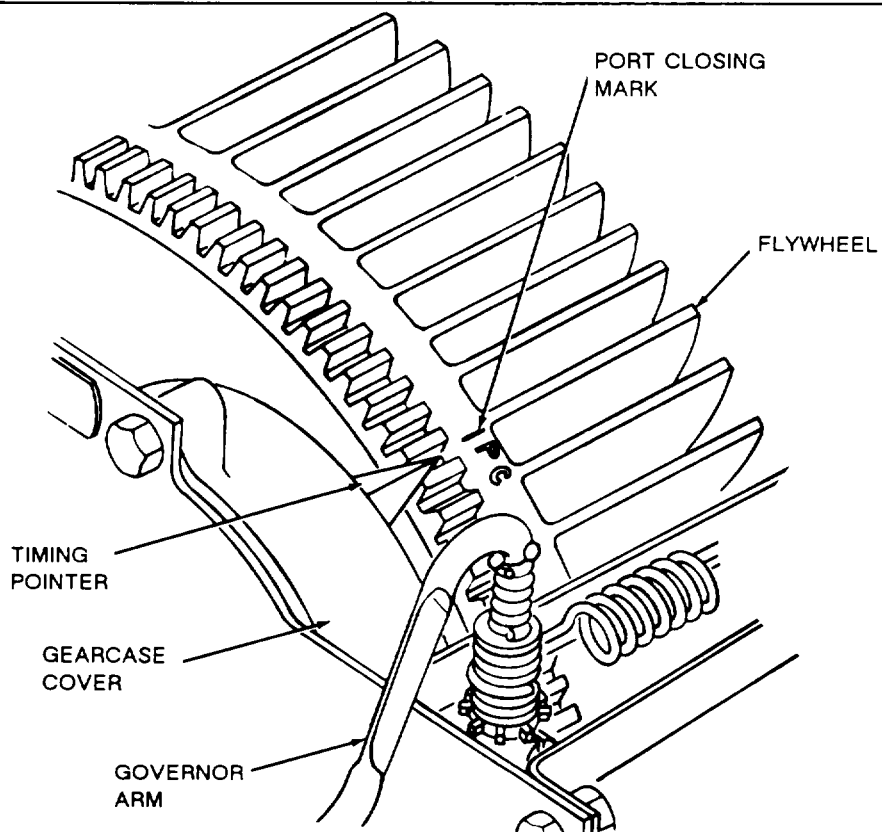
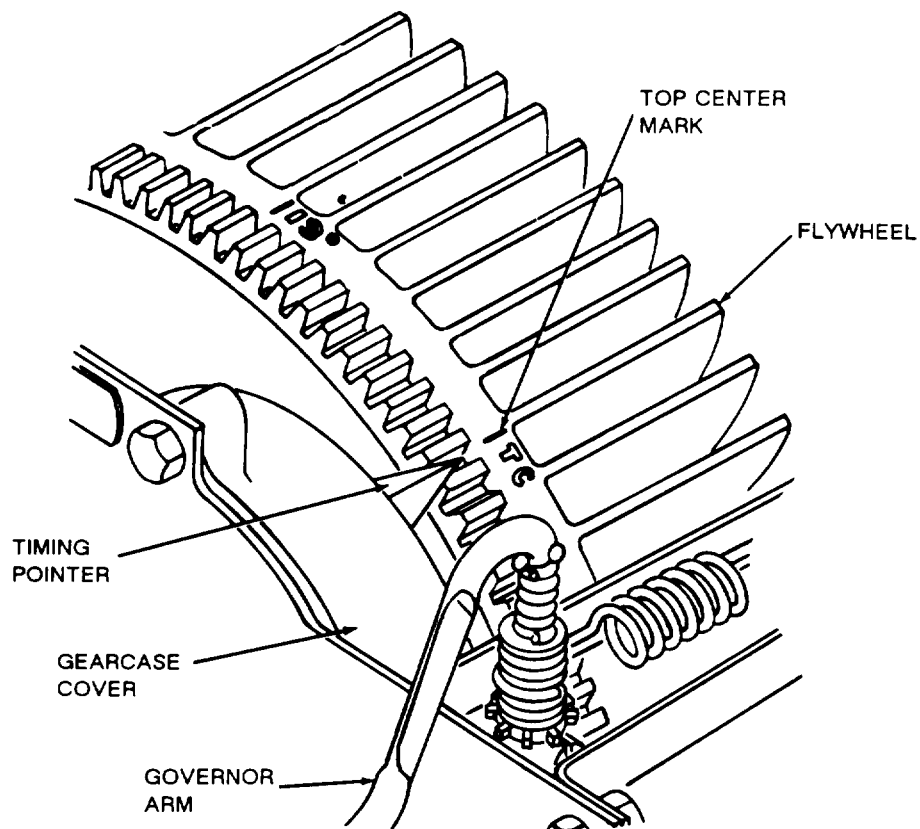

Figure 7-78. Top Center and Port Closing Marks

TA100149

(i) Check injection port closing point by repeating steps (c) through (f). The timing pointer should indicate the PC mark on flywheel. In no case should pointer be more than 1/2 mark away from the P.C. mark.

(j) Install delivery valve components. Be sure all parts are clean, and assembled carefully and properly. The delivery valve holder must be assembled with a twelve-point wrench, and retightened to 70-80 lb.-ft. The cap nut must be retightened to 55-60 lb.-ft.

**7-87. Nozzle Assembly Test and Adjustment**

The nozzle and holder assemblies are designed to open at 1900-1950 psi. However, after several hundred hours of operation, the nozzle pressure will decrease to an acceptable 1750 psi. To test and adjust the nozzle assemblies, it will be necessary to use a nozzle pressure tester or pressure gage that reads at least 2000 psi. The following steps describe test procedures using a pressure gage.

- a. Remove Number 1 cylinder nozzle and holder assembly from the engine.
- b. Disconnect fuel inlet line at nozzle and holder assembly. Attach nozzle inlet line from fuel injection pump to inlet end of pressure gage.
- c. Attach a flexible line to outlet end of pressure gage and to inlet end of nozzle. Be certain nozzle-to-fuel injection return line is attached.

**CAUTION**

**During nozzle test procedures, all nozzles must be removed from the engine. Failure to do so may result in damage to the engine.**

d. Remove Number 2, Number 3, and Number 4 cylinder injection nozzles and holder assemblies from engine, and reconnect fuel inlet and return lines. Use additional lines and fittings of same gage and material as required to direct nozzle away from engine.

**WARNING**

**Do not allow nozzle spray to contact skin. Diesel fuel under pressure can penetrate flesh and cause serious injury and infection.**

e. Crank engine and observe pressure gage at moment fuel is ejected from nozzle. The pressure gage should read at least 1750 psi opening pressure.

f. To adjust opening pressure, remove set-screw and back off adjusting nut cover several turns. Insert allen wrench through adjusting nut cover and into adjusting nut. Turn adjusting nut clockwise to increase pressure and counterclockwise to decrease pressure. Some chattering of the nozzle is normal during pressure test.

**NOTE**

**If streamers of fuel are visible or the nozzle drips before it reaches opening pressure of 1750 psi minimum, the nozzle is either dirty or defective. If dirty, clean nozzle and valve. If defective, replace nozzle and valve together.**

g. After adjusting nozzle opening pressure, continue to crank the engine and observe the nozzle spray pattern. A good spray pattern (fig. 7-79) will be cone shaped with a solid appearing center surrounded by cloud-like fog, with the spray evenly atomized.

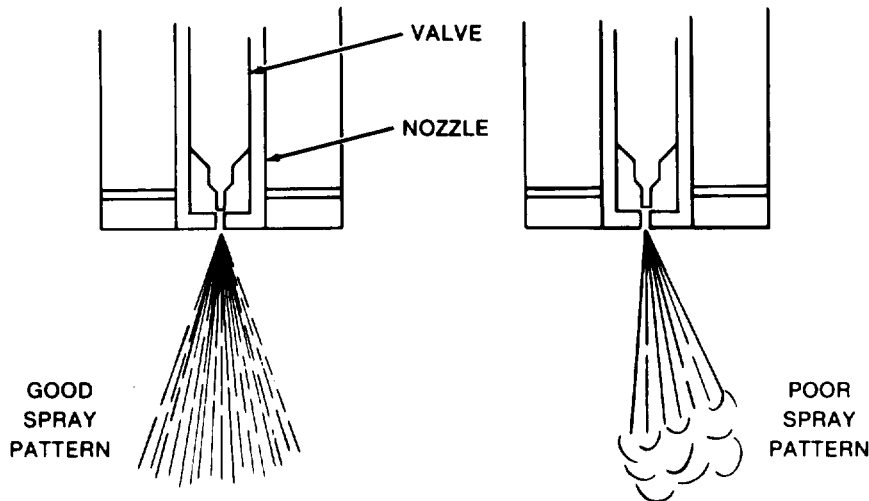

Figure 7-79. Nozzle Spray Pattern.

TA100150

*h.* Disconnect pressure gage from Number 1 cylinder nozzle and holder assembly. Attach fuel inlet and return lines, and then repeat above procedures to test and adjust Number 2 cylinder nozzle and holder assembly.

*i.* Repeat step *h* for Number 3 and Number 4 cylinder nozzle and holder assemblies.

**7-88. Valve Rocker Arm Adjustment**

**NOTE**

**Readjust rocker arm-to-valve clearance after the first 50 hours of operation on a new or rebuilt engine.**

*a.* Check and adjust the rocker arm to proper valve clearance every 500 operating hours.

*b.* Always check and adjust the valve tappet clearance when the engine is at an ambient temperature of approximately 70°F. Remove rocker cover and proceed as follows:

**CAUTION**

**Turn blower wheel clockwise only.**

(1) Using a 5/8-inch socket wrench and extension, turn the blower wheel clockwise until Number 1 cylinder

is on its compression stroke, which follows the closing of its intake valve. See figure 7-80 for identification of intake valve assembly.

(2) Continue clockwise rotation until TC (top center) mark on flywheel lines up with timing pointer on gear cover (fig. 7-78). Then turn flywheel in a clockwise direction for an additional 10°-450. The timing mark for this position must be established. In this position, the piston will be in its power stroke with both valves completely closed.

(3) Using a feeler gage, check the clearance between the rocker arm and the valve stem cap (fig. 7-80). Increase or reduce the clearance until the proper gap is established, adjusting the lock nut which secures the rocker arm to the cylinder head. Correct valve clearance is 0.009-inch for intake valves and 0.007-inch for exhaust valves.

(4) To adjust the valve clearance for Number 2 cylinder, turn the blower wheel clockwise 180° until the flywheel is 10°-450 past the BC (bottom center) mark and adjust valves as given in step (3).

**7-89. Cylinder Head Compression Test, On Equipment**

*a.* Remove shroud door panel on engine to gain access to the air intake manifold.

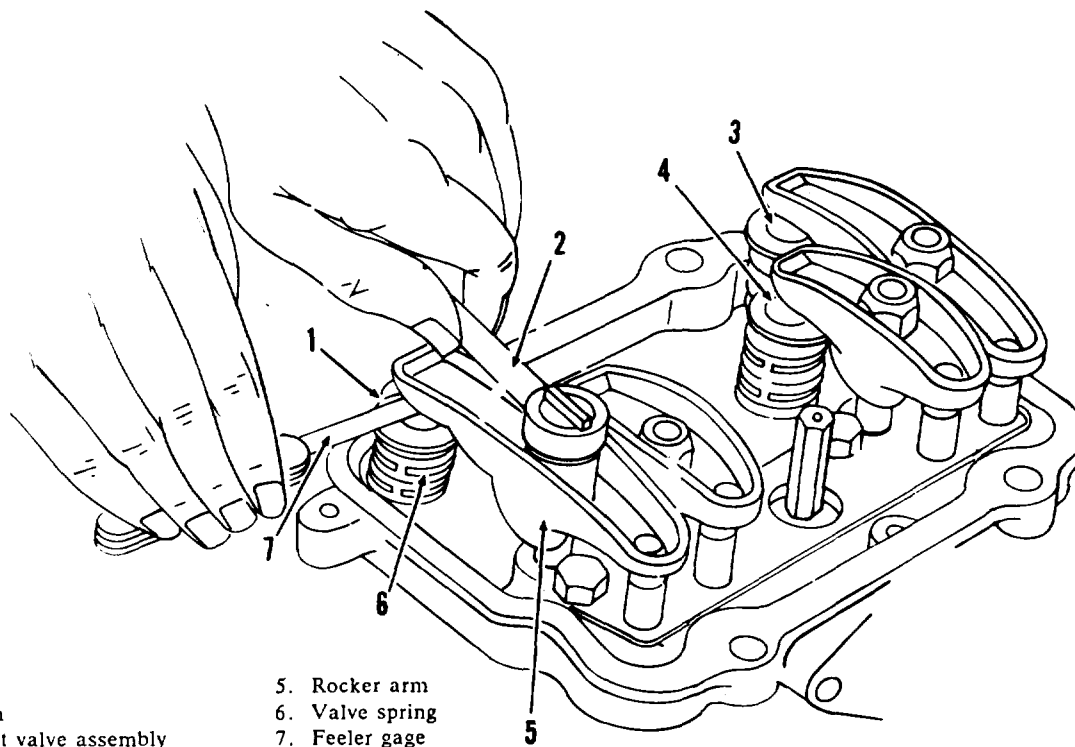

- 1. Valve
- 2. Wrench
- 3. Exhaust valve assembly
- 4. Intake valve assembly

- 5. Rocker arm
- 6. Valve spring
- 7. Feeler gage

TA100151

**Figure 7-80. Checking and Adjusting Rocker Arm-to-Valve Clearance.**

- b. Remove air intake manifold (para 4-82).
- c. Remove four fuel injectors (para 7-28).
- d. Insert a compression gage and adapter (table 5-1 and fig. 7-25) into the Number 1 cylinder fuel injector opening in the cylinder head. Secure the adapter to the cylinder head with two 5/16-18 NC x 3/4 capscrews.

**NOTE**

**The best indication of compression leakage is the pressure difference between cylinders. Compression of a standard new engine cranking at about 300 rpm is approximately 350-400 psi. Maintenance should be considered if pressure is below 325 psi or if there is a 15% or more difference between cylinders.**

- e. Turn the engine START switch to the start position to crank the engine. Record the compression reading on the gage as the engine is being cranked.
- f. Remove the compression gage and adapter. Insert adapter in Number 2 cylinder fuel injector opening. Secure with two capscrews.
- g. Turn the engine START switch to the start position and crank engine. Record the compression reading on the gage as the engine is being cranked.
- h. Repeat steps f and g for Number 3 and Number 4 cylinders.
- i. Install fuel injectors (para 7-46).
- j. Install air intake manifold (para 4-82).
- k. Replace shroud door panel.

**7-90. Starter Tests**

a. *On Equipment Test.* Refer to paragraph 4-79 for on equipment test.

b. *Bench Tests.*

(1) *Testing Starter.*

(a) If starting motor tests are required, remove the motor from the engine and test it on a bench. Test the free-running voltage and current.

(b) Using a spring scale and torque arm, test the stall torque (Fig. 7-81). Multiply the spring scale reading by the arm length for the torque value.

(c) If free running speed is low, and starter has a high current draw with low stall torque, check for tight, dirty or worn bushings, bent armature shaft, or loose field pole screws, allowing armature to drag. Check also for shorted or grounded armature and field.

(d) A low free speed with low torque and low current draw indicates an open field winding, high internal resistance due to poor connections defective leads, broken or worn brushes, or scored, worn, or dirty commutator.

(e) High free speed with low developed torque and high current draw indicates shorted fields. Since there is no easy way to detect shorted field coils, replace and check for improved performance.

(f) The voltage drop across the solenoid on the starting motor should be less than 1.5 volts. If not, remove it for repair.

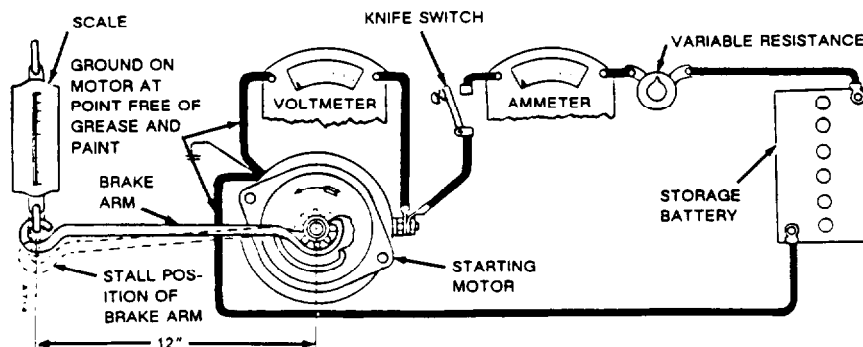
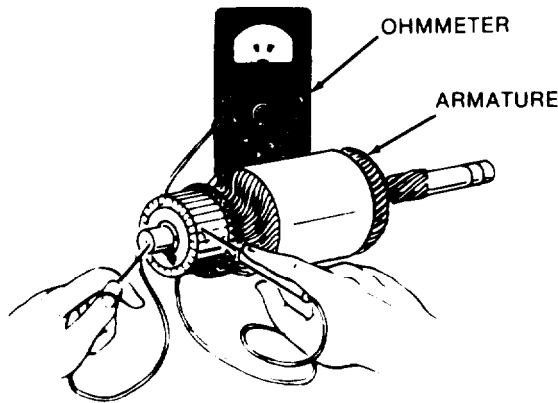

*Figure 7-81. Testing Stall Torque.*

TA504710

(2) Testing Armature.

(a) *Testing Armature for Grounds (Fig. 7-82).* Touch armature shaft and the end of each commutator bar with a pair of ohmmeter leads. There should be no continuity. If continuity is indicated between any commutator bar and shaft, it indicates a grounded armature. Replace starter.



TA100152

Figure 7-82. Testing Armature for Grounds.

(b) *Testing Armature for Shorted Coils (Fig. 7-83).* A growler is necessary to test for shorted coils. With the armature in the growler, turn the growler on and run a steel strip (such as a hacksaw blade) over the armature surfaces. If a coil is shorted, the steel strip will become magnetized and vibrate. Rotate the armature slightly and repeat the test. Do this for one complete revolution of the armature. If the armature has a short, replace starter.

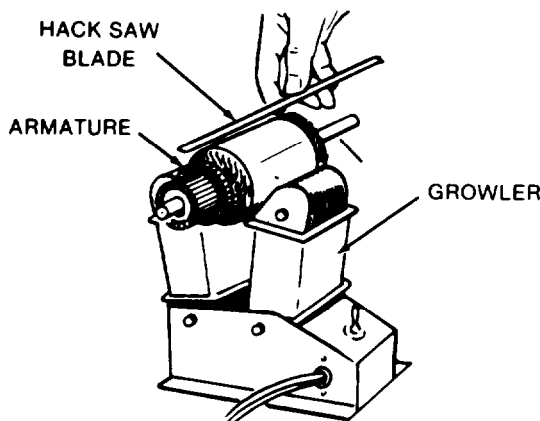

TA100153

Figure 7-83. Testing Armature for Shorted Coils.

(c) *Testing Amature for Open Coils.* Test coils for continuity with ohmmeter. A resistance reading indicates open coil.

(d) *Testing Commutator Runout (Fig. 7-84).* Place armature in a test bench and test runout with a dial indicator. When commutator runout exceeds 0.004-inch, replace starter.

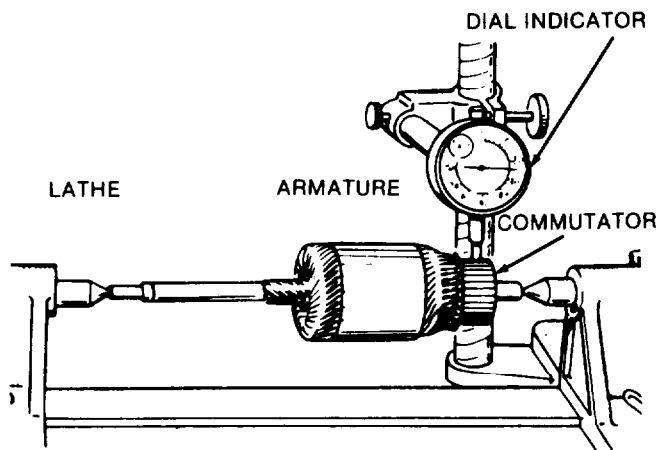

TA100154

Figure 7-84. Checking Commutator Runout.

(e) *Testing Armature Shaft Runout (Fig. 7-85).* Place armature in a test bench and check shaft runout with a dial indicator. If the shaft is bent or worn, starter must be replaced. Runout should not exceed 0.006-inch.

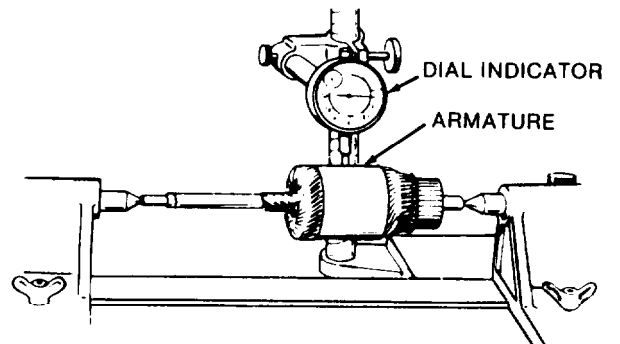

TA100155

Figure 7-85. Checking Armature Shaft Runout.

(3) Testing Field Coils.

(a) Using a test lamp and probes, check the field coils for grounding to the motor frame or open circuit.

(b) Inspect all connections to be sure that they are properly clinched and soldered. Inspect the insulation for evidences of damage.

(c) The only way to check for field coil shorts is to use the starting motor bench test.

(4) *Testing Brush Springs (Fig. 7-86).* Measure brush spring tension with a tension meter. Push the brush and take a reading just as the brush projects a little from the brush holder. On a new brush the spring tension should be 32-40 ounces. If brush spring tension is below 20 ounces, replace. Spring tension can be changed by twisting the spring at the holder with long nose pliers.

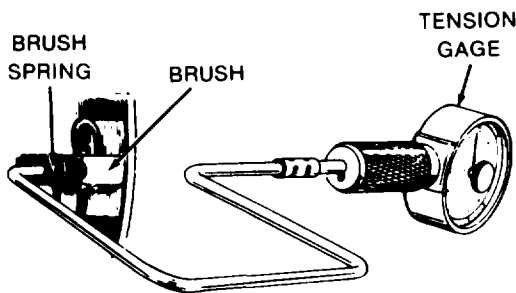

TA100156

Figure 7-86. Testing Brush Spring Tension.

(5) *Testing Solenoid Switch (Fig. 7-87).*

(a) Ensure that plunger moves freely in coil. Measure the pull-in coil current draw by using Test A. Current should not exceed 16 amps.

(b) Measure the hold-in draw using Test B. Current should not exceed 6 amps.

(c) Total hold and pull current draw using Test C is 22 amps. Total current draw should not exceed 25 amps.

(d) Replace a solenoid that does not meet these test specifications.

c. *Test After Reassembly.*

(1) After the motor is assembled, check the armature end play by inserting thickness gage between thrust washer (21, fig. 7-62) and pinion housing (22). End play should be between 0.005-inch and 0.030-inch. Adjust end play by adding or removing thrust washers (21, fig. 7-62) on the commutator end of the armature.

(2) Before installing, check the pinion clearance. Proper clearance is important to ensure starter engage-

ment. Press on solenoid core to shift the pinion into full mesh. Measure the clearance between pinion and pinion stop (fig. 7-87). Clearance should be 0.07 to 0.12-inch. Adjust the link screw on the end of the solenoid plunger for proper clearance.

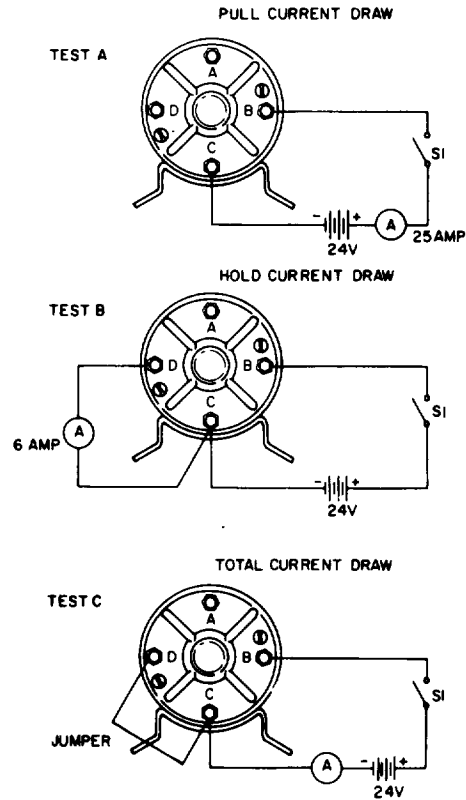

TA100157

Figure 7-87. Testing Solenoid Switch.

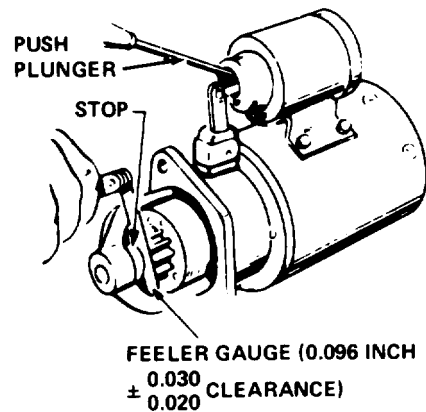

TA100158

Figure 7-88. Checking Pinion Clearance.



### 7-91. Alternator Test and Adjustments

a. *Test, On Equipment.* Before doing the following test, check battery condition (para 3-6 and 4-23), alternator drive belt (para 4-78), and wiring and connections (para 4-16).

(1) Connect an accurate voltmeter across the batteries and check battery voltage with engine not running. Record the voltage.

(2) Now start the engine and run it at approximately 1000 rpm. The voltmeter should show an increase from the reading obtained in step (1). If the voltage rises excessively (over 14.2V), the charging system may be defective or the voltage regulator needs adjustment.

#### NOTE

**Do not attempt to adjust regulator voltage if batteries are in low state of charge. System voltage will increase as the batteries receive a charge.**

b. *Voltage Adjustment.* If batteries are constantly undercharging or overcharging, and all other causes, such as bad connections, damaged wiring, or slipping drive belt have been checked, make the following adjustment:

(1) Connect an accurate voltmeter across the batteries and run engine at approximately 1000 rpm.

#### CAUTION

**Do not attempt to turn the adjustment screw past its internal stops or damage will result.**

(2) Remove nylon screw (fig. 7-89) from voltage regulator. Turn adjustment screw with a small screwdriver and attempt to bring voltage to proper setting (13.6-14.2V). The ideal setting will be a value which maintains the batteries in a fully charged condition without excessive water usage.

(3) Install nylon screw after adjusting to prevent entrance of dirt and water.

(4) If output voltage is excessively high and cannot be lowered by turning the adjustment screw, replace voltage regulator.

(5) If output voltage is low and cannot be increased by turning the adjustment screw, remove the alternator for further testing and repair.

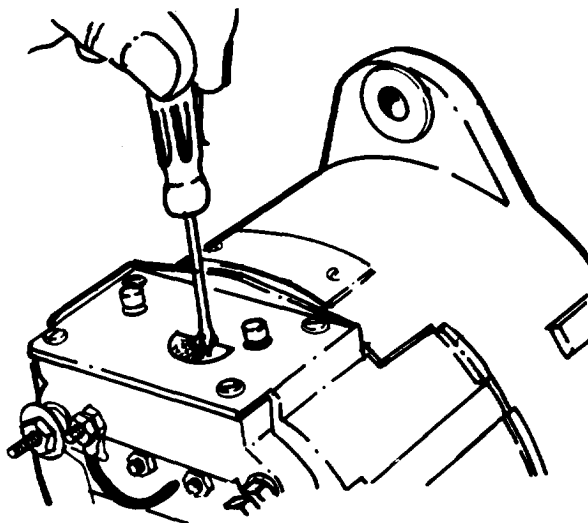

TA100159

Figure 7-89. Voltage Adjustment.

c. *Bench Test.* This test can be performed to determine if the fault is in the alternator, voltage regulator, or diode trio. Because the voltage regulator is built into the alternator, the test block arrangement is simple. If a commercial test block is not available, use the arrangement shown in figure 7-90.

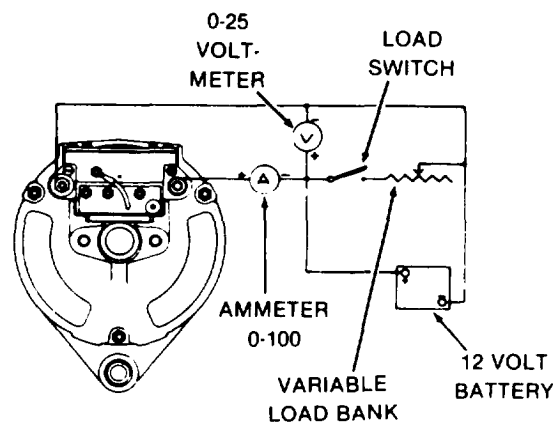

TA100160

Figure 7-90. Test Block Arrangement.

(1) Connect one end of a short jumper lead to negative output terminal. Connect opposite end of jumper lead to a short stiff piece of wire at least 1 1/2-inches long. Insert this wire into the small hole in end of brush holder so that it firmly contacts the outer brush terminal (fig. 7-91). This procedure overrides the voltage regulator and gives a full field condition.

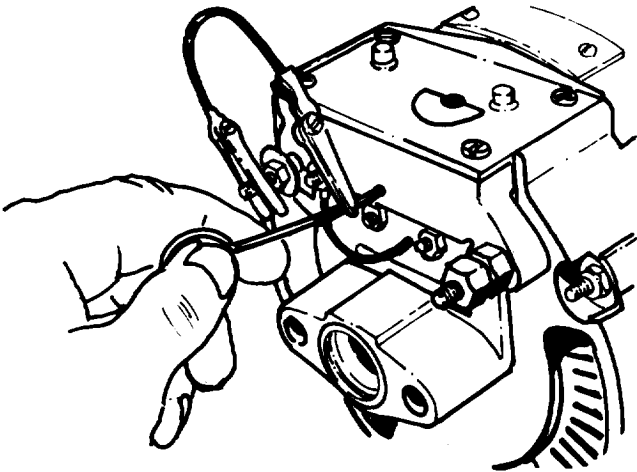

TA100161

Figure 7-91. Full Field Test.

(2) With alternator turning at approximately 1000 rpm, note the voltmeter reading. If the voltmeter rises as contact is made between the short piece of wire and the outer brush terminal, the alternator is good. Remove the diode trio and test. If the diode trio tests okay, the voltage regulator should be replaced.

(3) If the voltage fails to rise during the full field test, remove the voltage regulator and carefully inspect it for a printed circuit path that is burned open. This will generally be the track from the positive regulator terminal to one brush terminal. If this condition is found, replace the voltage regulator. Also check the brush spring caps

and their contact screws for dirt or corrosion, and clean as necessary. Retest alternator. If problem still exists, disassemble the alternator for further tests and inspections.

(4) The alternator may also be checked for output across each phase by using a test light (fig. 7-92). The test light should be a two filament sealed beam unit connected so the filaments are in parallel. Such a light will act as a load as well as an indicator. The test light should illuminate with equal brilliance on each phase (Test A, B, and C). If the light is noticeably dimmer on one or two phases, a defective diode trio, stator, or power diode is indicated.

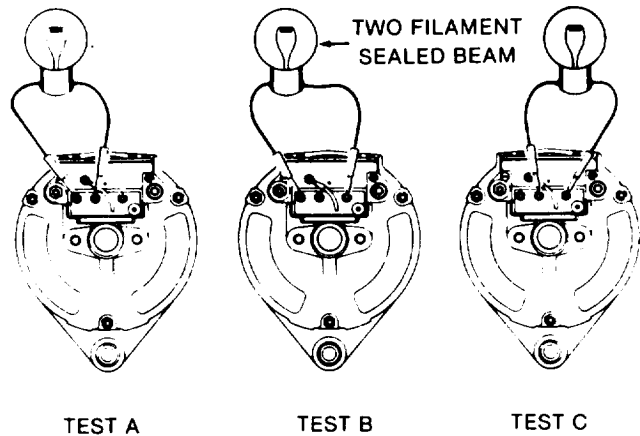

TA100162

Figure 7-92. Three Phase Test.

## CHAPTER 8 REPAIR OF PUMP, VALVES, AND DISPENSING EQUIPMENT

---

### Section 1. GENERAL

#### 8-1. Scope

This section contains procedures for disassembly, cleaning, repair, and assembly of the pump, valves, and dispensing equipment which are beyond the scope of the using organization.

#### 8-2. Precautions

#### WARNING

**Read and observe all safety precautions in Warning Summary before performing maintenance on pump, valves, and dispensing equipment. Ensure that semitrailer is grounded to an approved (earth) ground and it is safe to proceed. Failure to follow this**

warning may result in serious injury or death to personnel.

*a.* Read and observe all safety precautions in the Warning Summary before beginning work.

*b.* Drain all valves and piping in the area before attempting to remove or disassemble valves or system components.

*c.* Ground semitrailer to an approved (earth) ground.

*d.* The area must be rated safe.

*e.* Ensure that work area is kept clean. Cleanup any fuel spills IMMEDIATELY.

### Section II. CENTRIFUGAL PUMPS

#### 8-3. Pump, 4-inch (M967, M967A1, M969, and M969A1) (Fig. 8-1)

*a. Air Leakage Test.* Before removal, the following test can be performed to determine whether pump or a loose connection is the cause of problem. Air leaks at the inlet of pump will cause noisy operation and decreased pump outlet. A vacuum gage is needed for this test.

(1) Remove a pipe plug (31) in the suction side of the pump. Use pipe seal compound on the pipe threads. Install a vacuum gage in the plug.

(2) Make sure the pump is filled with fluid, and start the pump.

(3) At operating speed, the pump should pull a minimum of 20-inches of vacuum. This indicates that the gaskets and seals are good.

(4) Stop the pump. Observe whether vacuum remains at the maximum developed by the pump. If vacuum falls off rapidly, an air leak exists. Be sure that leakage is not coming from pipe plug or vacuum gage connection.

(5) If leakage is indicated, tighten flange connections and repeat test before removing pump for repairs.

*b. Removal.* Remove pump and coupling (para 5-22).

*c. Disassembly (Fig. 8-1).*

(1) Remove pipe plug (30) on bottom of intermediate housing (3) and drain the lubricant.

(2) Remove eight nuts (1) and lockwashers (2). Use a soft hammer to loosen the intermediate housing (3) and seal plate (15). Carefully remove the intermediate housing, seal plate, and impeller (20) as an assembly from volute (23). Discard gasket (19).

(3) The impeller (20) is threaded on the impeller shaft (8). The impeller will unscrew in the same direction as the pump runs. To remove impeller:

*(a)* Put a strap wrench around discharge surface of the impeller as near as possible to the seal plate (15).

*(b)* If pump coupling was removed earlier, temporarily install the pump coupling and wedge a pry bar between coupling and intermediate housing to hold the impeller shaft.

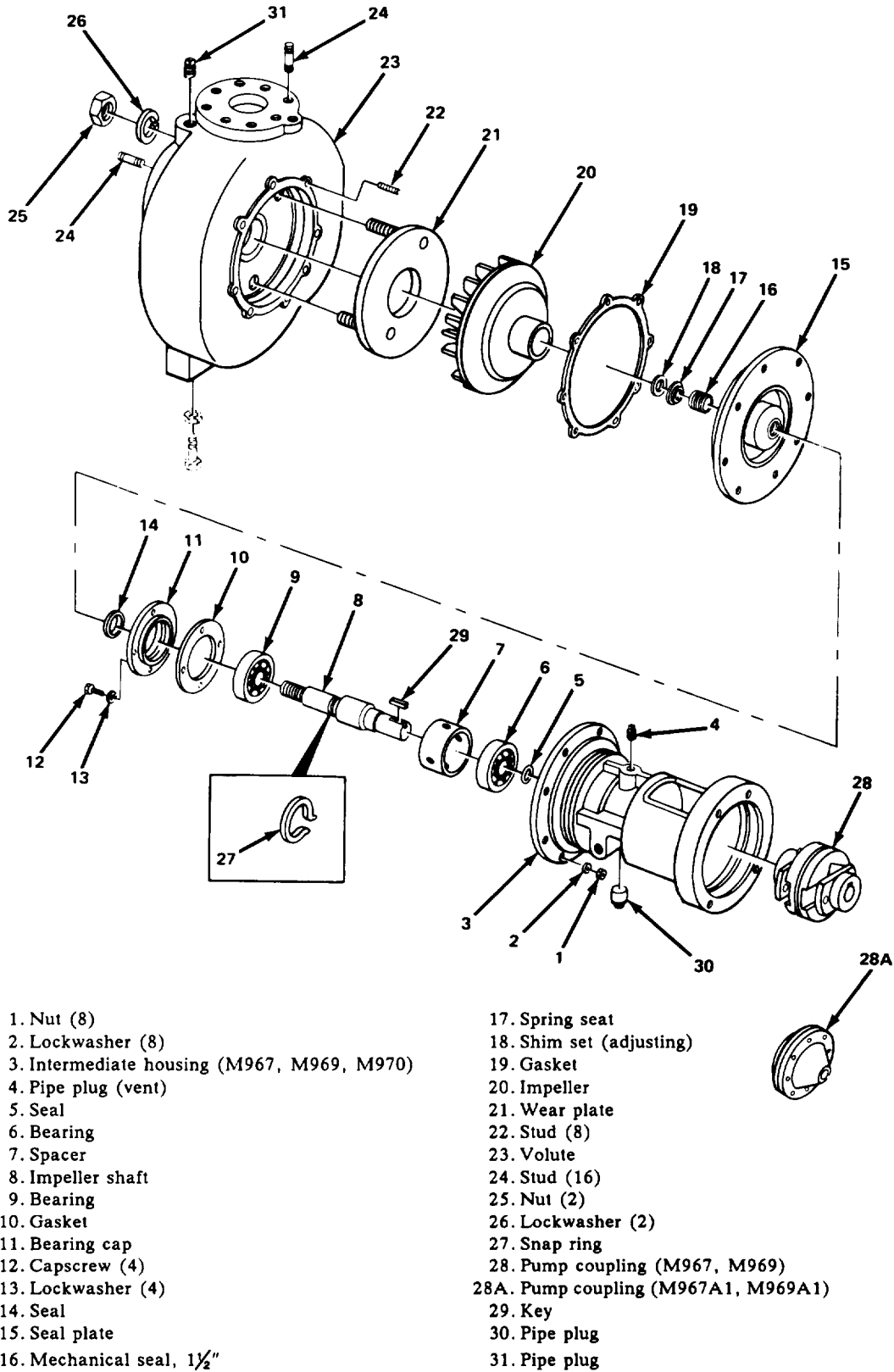

Figure 8-1. Centrifugal Pump, 4-inch (M967, M967A1, M969, and M969A1).

TA504711

**WARNING**

**Be careful when removing the Impeller from the pump. The spring load on the mechanical seal may cause the impeller to fly off the shaft as it is being removed, causing serious injury to personnel.**

(c) Apply force to strap wrench in a counterclockwise direction. Using a block of hard wood and a hammer, hit the hub of impeller to loosen it on the shaft. Remove the impeller by unscrewing it from the impeller shaft.

(4) Pull the seal plate (15) and the mechanical seal (16) from the impeller shaft.

(5) Remove four capscrews (12) and lockwashers (13) from bearing cap (11). Remove the bearing cap and discard gasket (10).

(6) Remove pump coupling (28) and key (29) from opposite end of shaft, if these items were not already removed.

(7) Using a soft hammer, hit the keyed end of the impeller shaft to remove the shaft (8), bearings (9 and 6), and spacer (7) from intermediate housing (3).

(8) Remove seal (5) from intermediate housing. Discard the seal.

(9) Remove the seal (14) from the bearing cap (11). Discard the seal.

(10) Remove snap ring (27), bearing (9), and bearing (6) from impeller shaft (8).

(11) The wear plate (21) is fastened to the volute with two nuts (25) and lockwashers (26). Remove the wear plate only if excessive wear is evident and replacement is necessary (step e).

d. *Cleaning.* Refer to paragraph 5-8.

e. *Inspection and Repair (Fig. 8-1).*

(1) *Impeller and Wear Plate.* The open impeller (20) uses a wear plate (21) in front of the impeller vanes to minimize internal pump leakage. This wear plate normally receives most of the wear. Pump efficiency will decrease considerably when the clearance between the wear plate and impeller exceeds 0.035-inch. Normally, shims (18) can be added to bring clearance within limits.

(a) Add shims until rubbing just starts to occur when the impeller and wear plate are secured in place.

(b) Then remove enough shims to move the impeller away from the wear plate a distance of 0.015-inch.

(c) Rotate the pump by hand to make sure the impeller is not binding or scraping.

(d) Minor nicks on edges of impeller vanes can be removed by finishing with a fine stone.

(e) If the impeller and wear plates are worn excessively, they must be replaced.

(f) After replacement of the impeller, wear plate, or impeller shaft, check for clearance between the BACK of the impeller and the seal plate. If the impeller scrapes when the seal plate (15) is installed, add another gasket (19) of sufficient thickness between the seal plate and the pump casing.

(2) *Mechanical Seal (16).* Inspect the mating surfaces of the seal for wear, scoring, grooves or other damage which can cause leakage. If any of the seal parts are worn, replace the entire seal. Never mix old and new parts of a seal.

(3) *Impeller Shaft (8).* Inspect the impeller shaft for nicks, scratches, scoring or other damage. Replace the shaft if damaged.

(4) *Bearings (6 and 9).* Rotate bearings by hand and check for binding or wear. Replace bearings if wear is found. The bearings are a light press fit on the impeller shaft and a snug push fit in the housing. If the shaft is worn so the bearing slips on and off easily, the shaft must be replaced. Replace the housing if the bearings do not fit snugly into the bearing bore.

(5) *Gaskets and Seals.* Whenever a pump is overhauled, oil gaskets should be replaced. However, if old gaskets must be reused, soak the gaskets in water to prevent them from drying out and shrinking. Inspect all seals carefully and replace any that are damaged.

*Assembly (Fig 8-1).*

(1) Install new seal (5) in bore of intermediate housing. Lip of seal must be toward the impeller.

**NOTE**

**Loading groove in bearings must be installed toward the shoulder or center (largest diameter) of the impeller shaft.**

(2) Press bearing (9) over threaded end of impeller shaft (8) and install snap ring (27).

(3) Put spacer (7) onto impeller shaft against bearing just installed. Press bearing (6) with loading groove towards spacer onto keyed end of impeller shaft (fig. 8-2).

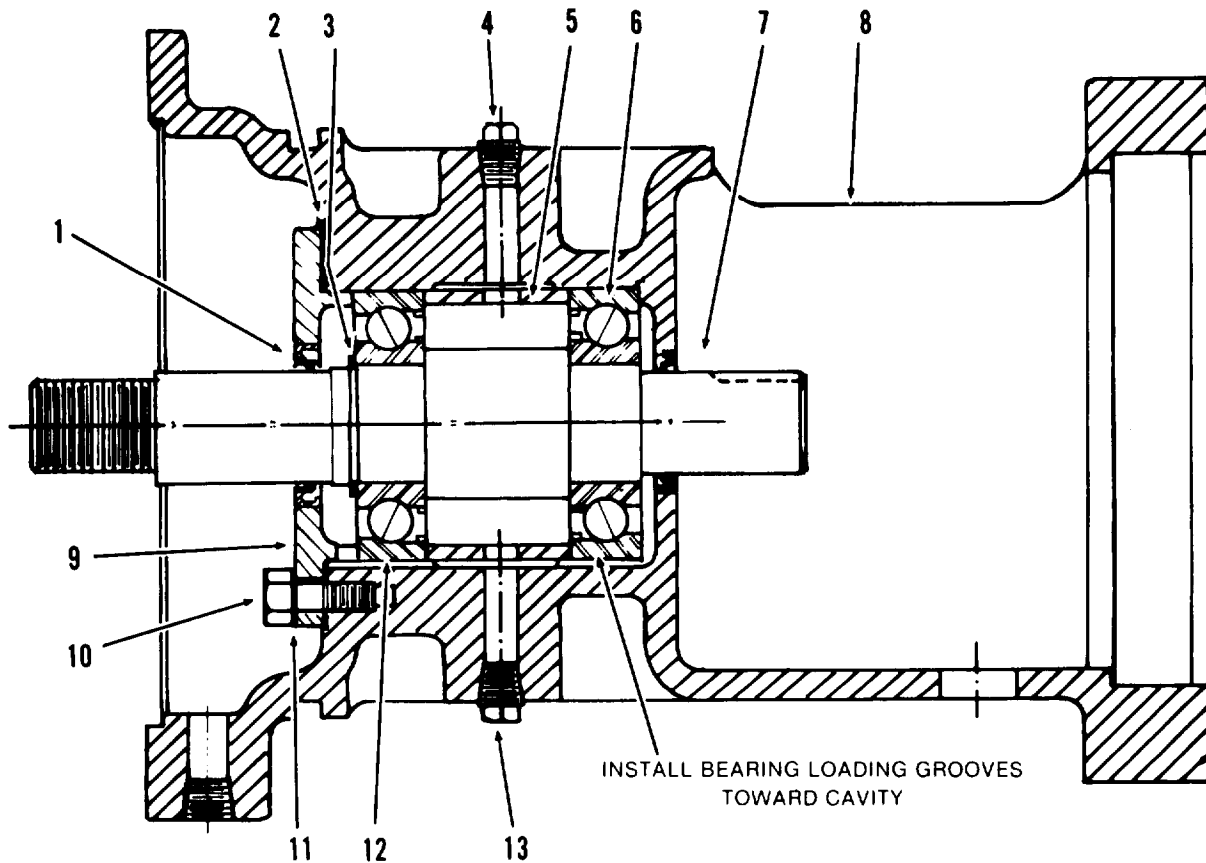

- |   |  |
|---|--|
| <ul style="list-style-type: none"> <li>1. Seal</li> <li>2. Gasket</li> <li>3. Snap ring</li> <li>4. Pipe plug (vent)</li> <li>5. Spacer</li> <li>6. Bearing</li> <li>7. Impeller shaft</li> </ul> | <ul style="list-style-type: none"> <li>8. Intermediate housing (M967, M969, M970)</li> <li>9. Bearing cap</li> <li>10. Capscrew (4)</li> <li>11. Lockwasher (4)</li> <li>12. Bearing</li> <li>13. Pipe plug (drain)</li> </ul> |
|---|--|

TA504713

**Figure 8-2. Pump Intermediate Housing Assembly.**

(4) Install impeller shaft and bearing assembly into intermediate housing (fig. 8-2). Use a soft hammer to tap the shaft and bearings into position.

(5) Install new seal (14, fig. 8-1) in bearing cap (11). Lip of seal must be towards the inside of cap.

(6) Put anew gasket (10) on flange of bearing cap (11) and carefully slide the bearing cap over threaded end of the impeller shaft. Use care not to damage the seal (14). Fasten bearing cap to intermediate housing with four capscrews (12) and lockwashers (13).

(7) Install mechanical seal and seal plate (fig. 8-3). Use care to keep the seal parts free from dirt and other foreign material.

(a) Apply coating of lightweight oil to the O-ring of the stationary seal, then install the seal assembly

into the seal plate (4, fig. 8-3). Push the seal assembly squarely and firmly into the bore of the seal plate.

(b) Make sure the impeller shaft is clean and smooth. Apply light oil to the surface of the shaft where the seal will contact it.

(c) Slide the seal plate onto end of impeller shaft, using care not to damage the stationary seal.

(d) Slide the rotating seal parts on the impeller shaft as far as they will go.

(e) Install the spring of the rotating seal, making sure that it is seated properly.

(f) Install spring seat (2, fig. 8-3) and impeller, using shims (1, fig. 8-3) as required to obtain proper running clearance on the impeller (step e).

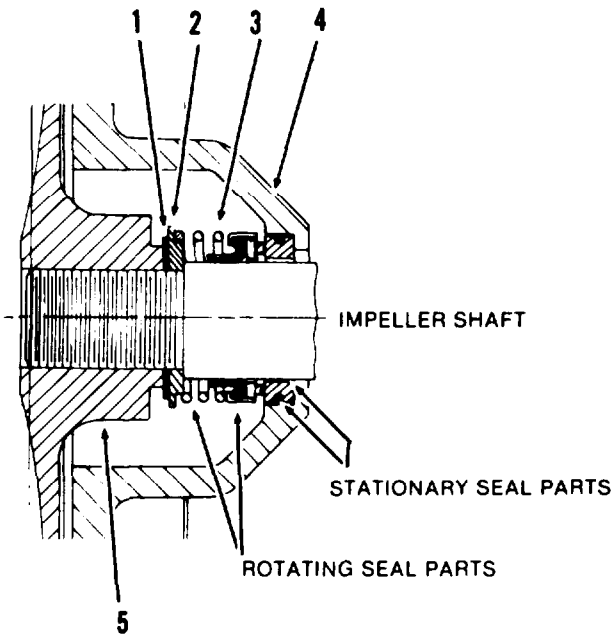

- |                    |               |
|--------------------|---------------|
| 1. Shim(s)         | 4. Seal plate |
| 2. Spring seat     | 5. Impeller   |
| 3. Mechanical seal |               |

TA100165

Figure 8-3. Installation of Mechanical Seal.

(8) After adjustment for proper running clearance is made, tighten impeller securely.

(9) If wear plate (21, fig. 8-1) was removed, install new wear plate in pump casing and fasten with two nuts (25) and lockwashers (26).

(10) Put anew gasket (19) over studs (22) of volute. Install seal plate assembly and intermediate housing assembly (3). Check and adjust the clearance between the impeller vanes and the wear plate (step e). Install lockwashers (2) and nuts (1) and tighten securely.

(11) Install pipe plug (13, fig. 8-2). Refer to Section I, Chapter 3, and fill the intermediate housing with the proper lubricant.

g. *Installation.* Install pump and coupling (para 5-22).

**8-4. Pump, 3-inch (M970 and M970A1)**

a. *Air Leakage Test.* Perform preliminary test before removing pump (para 8-3a).

b. *Removal.* Remove pump and coupling (para 5-22).

c. *Disassembly (Fig. 8-5).*

(1) *Impeller (10) and Wear Ring (9).* For access to the impeller, remove nuts (17) and lockwashers (16).

Carefully separate the intermediate housing and seal plate as an assembly from the volute (7). Discard gasket (11).

(a) To remove impeller (10), use instructions in paragraph 8-3c.

(b) The enclosed impeller uses a wear ring (9) to keep internal pump leakage at a minimum. When the clearance exceeds the limits shown in figure 8-4, the impeller and/or wear ring must be replaced.

(c) To remove wear ring (9), use a suitable puller.

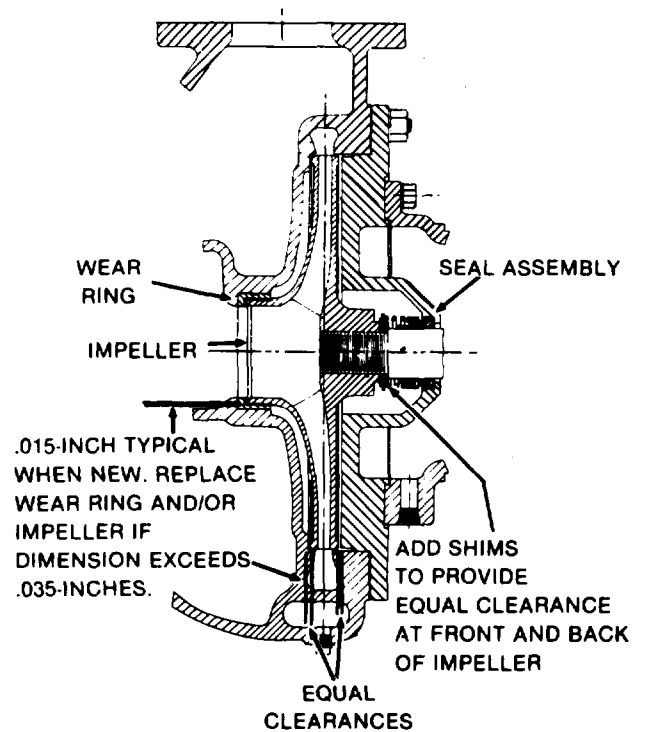

TA100166

Figure 8-4. Wear Limits of Impeller and Wear Ring.

(2) *Seal Plate and Mechanical Seal.* The arrangement for the mechanical seal is the same as the 4-inch pump. Use the following procedure to remove the seal:

(a) Remove pipe plug (34) on bottom of intermediate housing and drain lubricant.

(b) Remove impeller (10) using instructions in paragraph 8-3c.

(c) Remove eight capscrews (28) and lockwashers (27) and pull the seal plate (15) and mechanical seal (14) from the impeller shaft as an assembly.

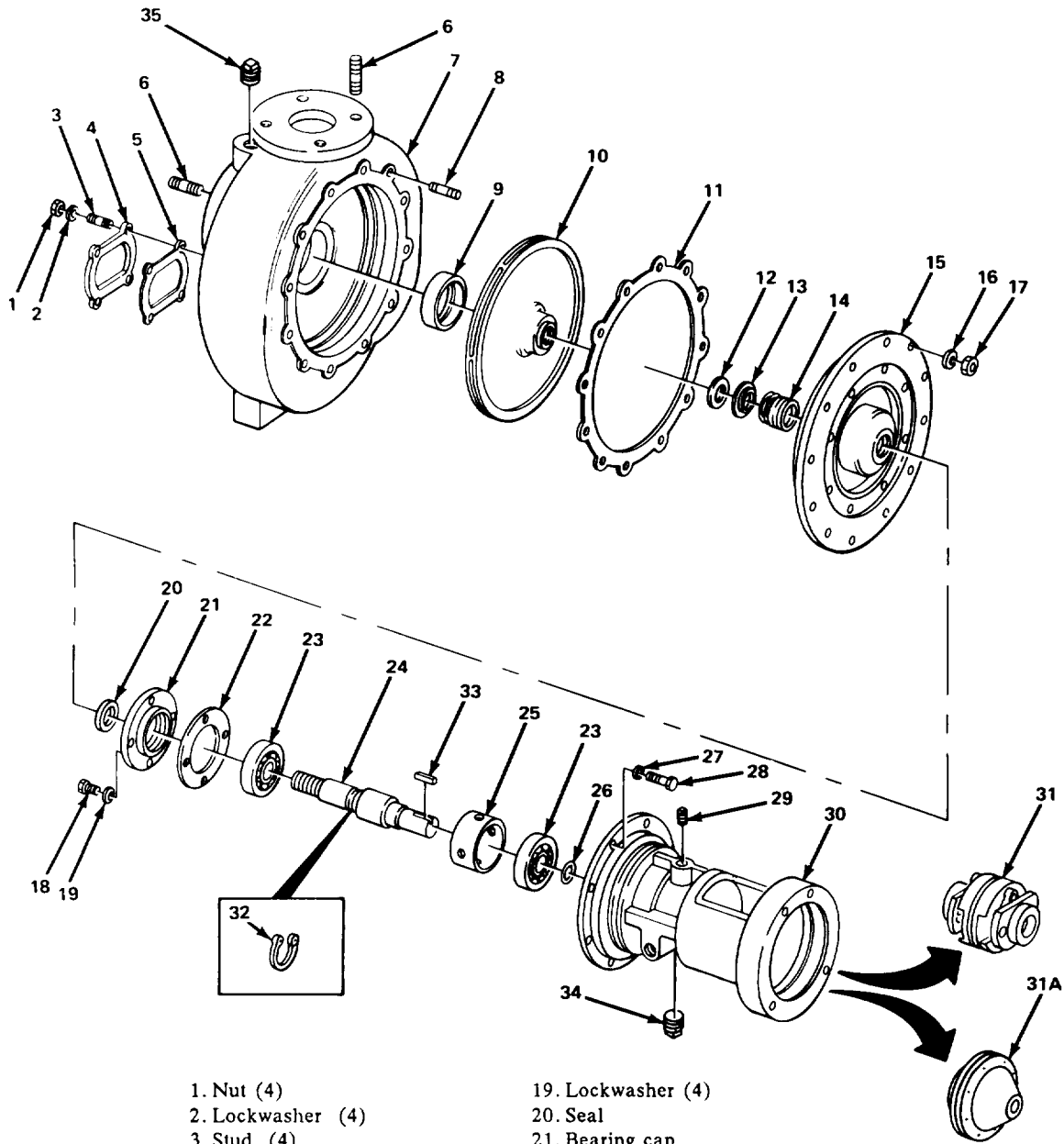

- |                          |   |
|--------------------------|---|
| 1. Nut (4)               | 19. Lockwasher (4)                          |
| 2. Lockwasher (4)        | 20. Seal                                    |
| 3. Stud (4)              | 21. Bearing cap                             |
| 4. Cover plate           | 22. Gasket                                  |
| 5. Gasket                | 23. Bearing (2)                             |
| 6. Stud (8)              | 24. Impeller shaft                          |
| 7. Volute                | 25. Spacer                                  |
| 8. Stud (12)             | 26. Seal                                    |
| 9. Wear ring             | 27. Lockwasher (8)                          |
| 10. Impeller             | 28. Capscrew (8)                            |
| 11. Gasket               | 29. Pipe plug (vent)                        |
| 12. Shim set (adjusting) | 30. Intermediate housing (M967, M969, M970) |
| 13. Spring seat          | 31. Pump coupling (M970)                    |
| 14. Mechanical seal, 1½" | 31A. Pump coupling (M970A1)                 |
| 15. Seal plate           | 32. Snap ring                               |
| 16. Lockwasher (12)      | 33. Key                                     |
| 17. Nut (12)             | 34. Pipe plug (drain)                       |
| 18. Capscrew (4)         | 35. Pipe plug                               |

Figure 8-5. Centrifugal Pump, 3-inch (M970 and M970A1).

TA504712



(3) *Intermediate Housing Assembly.* The arrangement of the bearings, spacer, seals, and impeller shaft in the intermediate housing are the same as the 4-inch pump. To disassemble the intermediate housing, use instructions in paragraph 8-3c.

d. *Cleaning.* See paragraph 5-8.

e. *Inspection and Repair.* Refer to figure 8-4 for wear limits on impeller wear ring. Refer to paragraph 8-3e for inspection and repair of remainder of parts.

f. *Assembly* (Fig. 8-5).

(1) Assemble seals, bearings, spacer, and impeller shaft in intermediate housing (para 8-3f).

(2) Install mechanical seal and seal plate using instructions in paragraph 8-3f, step 7. Fasten seal plate (15, fig. 5-5) to intermediate housing with eight capscrews (28) and lockwashers (27).

(3) If wear ring (9) is being replaced, install new wear ring in bore of volute (7). Make sure the ring is squarely and firmly seated in the bore.

(4) Install impeller (10) on impeller shaft and tighten securely.

(5) Install new gasket (11) over studs (8) on volute (7). Carefully install the seal plate and intermediate housing assembly over studs (8) on volute, and fasten with twelve nuts (17) and lockwashers (16).

(6) Rotate the pump by hand to make sure the impeller is not binding or scraping. Shims (12) can be added behind the impeller to center the impeller in the volute. The clearance between the front of the impeller and the seal plate should be equal to the clearance between the back of the impeller and the pump casing (fig. 8-4).

*g. Installation.* Install pump and pump coupling (para 5-22).

### Section III. HOSE REELS

#### 8-5. Hose Reels - 2½-inch (Fig. 8-6)

a. *Removal.* Remove hose reel (para 5-23).

b. *Disassembly* (Fig. 8-6).

(1) *Drum Disassembly.*

(a) Remove two capscrews (1), lockwashers (2), and flat washers (3) securing the pinion bearing assembly (hose reel lock) (5) to the front frame (6). Remove the pinion bearing assembly (5), spacer (4), and guard (75).

(b) Attach a suitable hoist to drum (48), and remove two capscrews (7), flat washers (8), lockwashers (9), and nuts (10). Then remove two capscrews (11), flat washers (12), lockwashers (13), and nuts (14). Lift drum assembly from front and rear frame (6 and 15), and place on a suitable workbench. Be sure to keep the two spacers (16 and 17) with the drum assembly.

(c) Remove six capscrews (18) and lockwashers (19) securing the swivel joint (20) to the adapter elbow (34). Remove the swivel joint (20) and O-ring (21). Discard the O-ring.

(d) Remove six nuts (76), lockwashers (77), and studs (23) securing the disc (22) to the six spacers (24). Remove the disc.

(e) Remove the six screws (25) and lockwashers (26). Remove the ring gear (27) and six spacers (28).

(f) Remove six capscrews (29) securing the bevel gear (30) to the disc (22). Remove the bevel gear.

(g) Remove capscrew (31), lockwasher (32), and nut (33) securing the adapter elbow (34) to the axle shaft (35). Remove the adapter elbow (34). Remove four capscrews (36) and lockwashers (37), and remove the outlet elbow (38) and O-ring (39). Discard the O-ring. Remove four capscrews (40) and lockwashers (41), and remove outlet adapter (42) and O-ring (43). Discard the O-ring.

(h) Remove drum (48).

(i) Loosen set screw (44), and pull axle shaft (35) and bearing and collar (45) from the disc (46) and collar (47). Put axle shaft in a bench vise and loosen set screw on bearing collar. Use a punch to rotate collar clockwise to release bearing and collar from axle shaft.

#### NOTE

**Take note of how many thrust washers, if any, are used between spacers and disc.**

(j) Remove six nuts (78), lockwashers (77), studs (49), and thrust washers (50). Remove six spacers (24).

(k) Remove six capscrews (51), lockwashers (52), and nuts (53) securing the collar (47) to the disc (46). Remove the collar.

(2) *Removal of Motor.*

**NOTE**

**Hose reel need not be removed from cabinet to remove motor.**

(a) Remove four machine screws (54). Remove cover (55). Tag and disconnect electrical leads from motor (56) at the motor junction box (57), and remove all conduit connections (para 4-27). Disconnect the motor junction box from bushing (58) and bushing from motor.

**WARNING**

**DO NOT remove nipple from motor. Nipple is packed in place with plaster. If nipple is removed, motor will no longer be explosion proof. Failure to follow this warning may result in serious injury or death to personnel.**

(b) Remove four screws (59), lockwashers (60), and nuts (61) securing motor (56) to mounting bracket (62) and to frame (6). Remove motor (56).

(c) Remove two screws (59), lockwashers (60), and nuts (61). Remove mounting bracket (62).

(d) Loosen set screw (63) and remove pinion gear (64).

(3) *Removal of Terminal Board in Motor Junction Box.*

(a) If motor was not previously removed under paragraph (2) above, remove the four machine screws (54) and cover (55). Remove two leads with terminals (11, fig. 8-7) that come from motor at the terminal board. Tag and disconnect all electrical leads from the terminal board (65) (para 4-27). Remove the two capacitors (66).

(b) Remove the two machine screws (67) securing the terminal board (65) to the junction box and remove the terminal board.

(4) *Disassembly of Frame.*

**NOTE**

**Drum and motor must be removed before complete disassembly of frame can be accomplished.**

(a) Remove four capscrews (68), washers (69), lockwashers (70), and nuts (71). Remove two tie rods (72).

(b) Remove eight capscrews (73), lockwashers (70), and nuts (71). Remove two side angles (74).

Legend for figure 8-6:

- |                            |                              |
|----------------------------|------------------------------|
| 1. Capscrew (2)            | 40. Capscrew (4)             |
| 2. Lockwasher (2)          | 41. Lockwasher (4)           |
| 3. Flatwasher (2)          | 42. Outlet adapter           |
| 4. Spacer                  | 43. O-ring                   |
| 5. Pinion bearing assembly | 44. Set screw                |
| 6. Front frame             | 45. Bearing and collar       |
| 7. Capscrew (2)            | 46. Disc                     |
| 8. Flatwasher (2)          | 47. Collar                   |
| 9. Lockwasher (2)          | 48. Drum                     |
| 10. Nut (2)                | 49. Stud (6)                 |
| 11. Capscrew (2)           | 50. Thrust washer (as req'd) |
| 12. Flatwasher (2)         | 51. Capscrew (6)             |
| 13. Lockwasher (2)         | 52. Lockwasher (6)           |
| 14. Nut (2)                | 53. Nut (6)                  |
| 15. Rear frame             | 54. Machine screw (4)        |
| 16. Spacer                 | 55. Cover                    |
| 17. Spacer                 | 56. Motor                    |
| 18. Capscrew (6)           | 57. Motor junction box       |
| 19. Lockwasher (6)         | 58. Bushing                  |
| 20. Swivel joint           | 59. Screw (6)                |
| 21. O-ring                 | 60. Lockwasher (6)           |
| 22. Disc                   | 61. Nut (6)                  |
| 23. Stud (6)               | 62. Mounting bracket         |
| 24. Spacer (6)             | 63. Set screw                |
| 25. Screw (6)              | 64. Pinion gear              |
| 26. Lockwasher (6)         | 65. Terminal board           |
| 27. Ring gear              | 66. Capacitor (2)            |
| 28. Spacer (6)             | 67. Machine screw (2)        |
| 29. Capscrew (6)           | 68. Capscrew (4)             |
| 30. Bevel gear             | 69. Washer (4)               |
| 31. Capscrew               | 70. Lockwasher (12)          |
| 32. Lockwasher             | 71. Nut (12)                 |
| 33. Nut                    | 72. Tie rod (2)              |
| 34. Adapter elbow          | 73. Capscrew (8)             |
| 35. Axle shaft             | 74. Side angle (2)           |
| 36. Capscrew (4)           | 75. Pinion guard             |
| 37. Lockwasher (4)         | 76. Nut (6)                  |
| 38. Outlet elbow           | 77. Lockwasher (6)           |
| 39. O-ring                 | 78. Nut (6)                  |

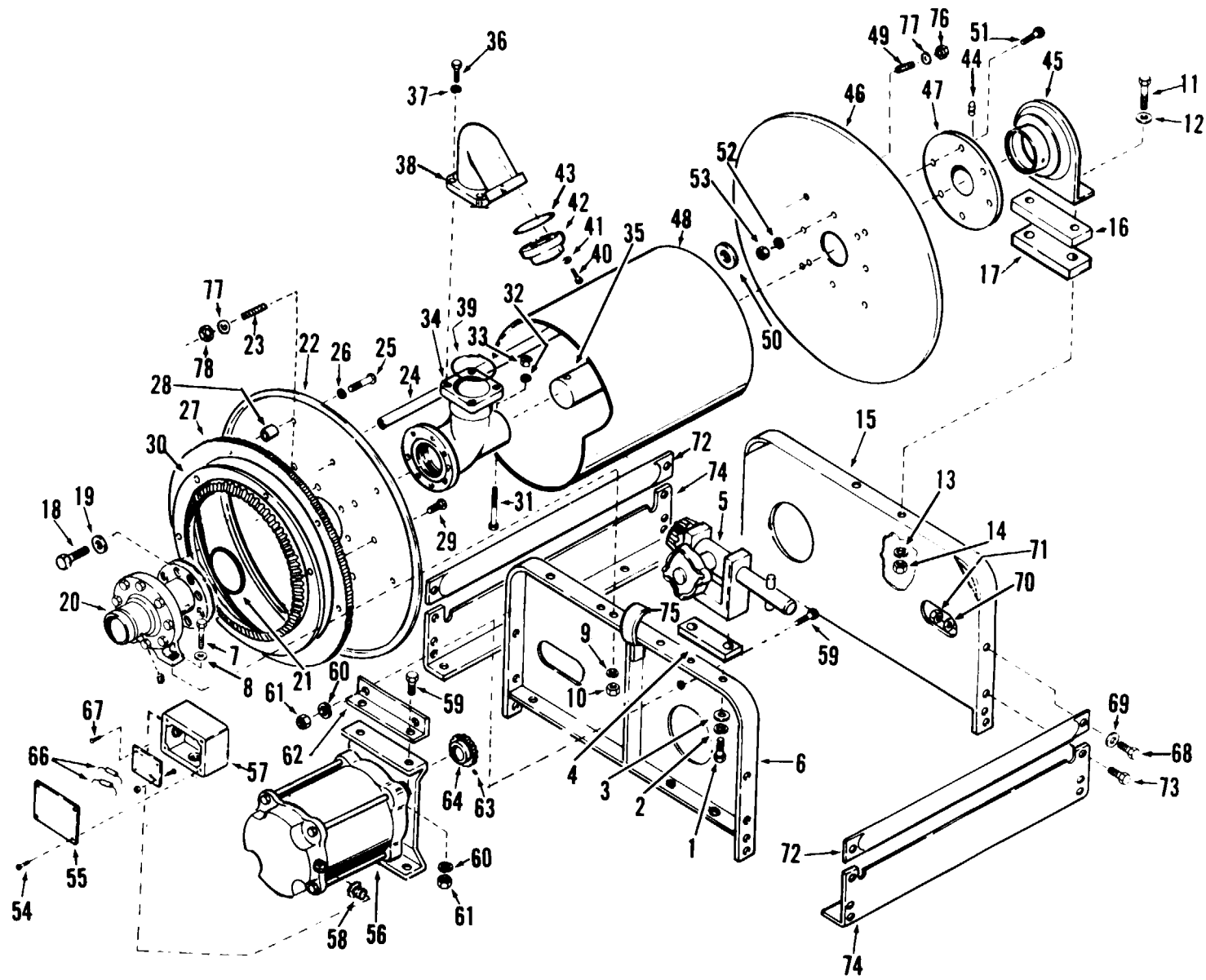

Figure 8-6. 2 1/2-inch Hose Reel.

TA100168

TM 9-2330-356-14

c. *Cleaning, Inspection, and Repair.*

**WARNING**

**Dry cleaning solvent P-D-680 is toxic and flammable. Always wear protective goggles and gloves, and use only in a well-ventilated area. Avoid contact with skin, eyes, and clothes, and DO NOT breathe vapors. DO NOT use near open flame or excessive heat. The solvent's flash point is 100°F-138°F (38°C-59°C). If you become dizzy while using cleaning solvent, immediately get fresh air and medical help. If solvent contacts eyes, immediately wash your eyes with water and get medical aid.**

(1) Clean metal parts with dry cleaning solvent (item 11, Appendix E) and dry thoroughly.

(2) Inspect gears for worn, damaged, or missing teeth. Replace gears if damaged.

d. *Assembly (Fig. 8-6).*

(1) *Assembly of Frame.*

(a) Position one side angle (74) onto the two frames (6 and 15). Secure in place with four capscrews (73), lockwashers (70), and nuts (71),

(b) Install other side angle (74) onto the two frames (6 and 15). Secure in place with four capscrews (73), lockwashers (70), and nuts (71).

(c) Install both tie rods (72) onto the frames (6 and 15). Secure with four capscrews (68), washers (69), lockwashers (70), and nuts (71).

(2) *Installation of Terminal Board in Motor Junction Box (Fig. 8-7).*

(a) Install the two nuts (2, fig. 8-7) on studs (1) on the terminal board (3). Install the middle capscrew (4) and one nut (5) onto the terminal board.

(b) Position the terminal in the motor junction box (6). Install screw (7) but do not tighten. Install capacitors (8 and 9) onto screw (7). Be sure capacitors are installed with marking in position shown in figure 8-7. Tighten screw (7).

(c) Install lead with terminal (11) from motor, along with capacitor lead, to terminal board. Secure with screw (10). Install motor lead with terminal (11) and capacitor lead to screw (4). Install second nut (5) and tighten.

(d) Reconnect hose reel wiring in motor junction box (para 4-27).

(e) Replace motor junction box cover (55, fig. 8-6) and secure in place with four machine screws (54).

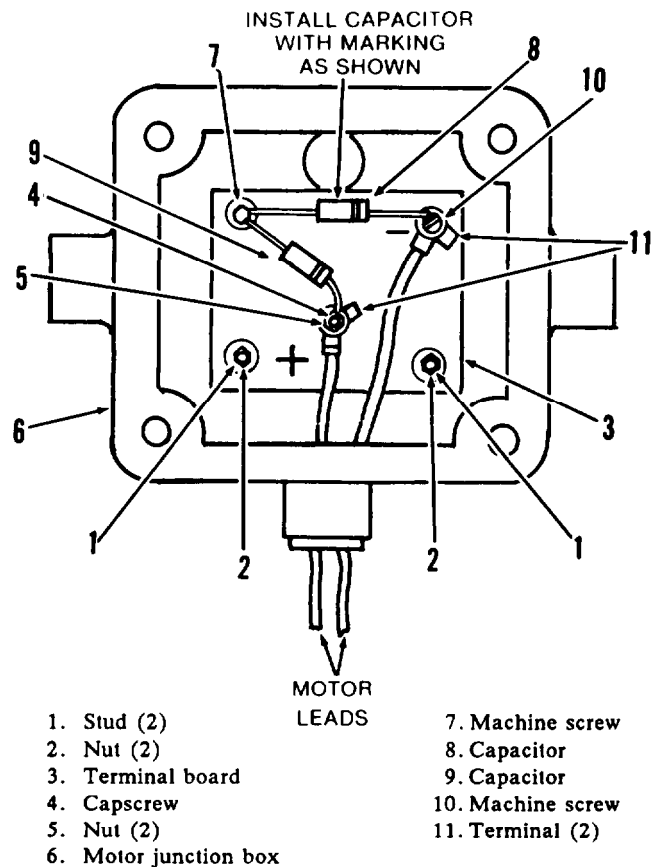

**TA100171**  
**Figure 8-7. Terminal Board Installation.**

(3) *Installation of Motor (Fig. 8-6).*

**NOTE**

**Be sure pinion gear teeth mesh properly with the ring gear teeth.**

(a) Install pinion gear (64) on motor shaft. Tighten set screw (63).

(b) Position motor between mounting bracket (62) and frame (6). Install four capscrews (59), lockwashers (60), and nuts (61).

(c) Install bushing (58) into junction box (57). Install assembly onto motor.

(d) Connect the two motor leads to the terminal board (65) in the junction box. Connect leads to terminal board and install conduit (para 4-27). Replace cover (55) and secure with four machine screws (54).

*(4) Drum Assembly.*

*(a)* Using six capscrews (51), lockwashers (52), and nuts (53), fasten the collar (47) to the disc (46).

**NOTE**

**Install original number of thrust washers that were removed at disassembly.**

*(b)* Install six spacers (24) and thrust washers (50) to disc (46). Secure with six nuts (78), lockwashers (77), and studs (49).

*(c)* Install bearing and collar (45) onto rudd shaft (35). Rotate collar counterclockwise to lock bearing and collar on axle shaft. Install axle shaft through collar (47) until bearing and collar (45) is against collar (47). Tighten set screw (44).

*(d)* Assemble the outlet elbow (38) by installing a new O-ring (43) between the outlet elbow (38) and the outlet adapter (42). Use four capscrews (40) and lockwashers (41) to secure the outlet elbow (38) and outlet adapter together. Assemble the outlet elbow (38) to the adapter elbow (34) by installing a new O-ring (39) between the outlet elbow (38) and the adapter elbow (34). Use four capscrews (36) and lockwashers (37) to secure the two elbows (34 and 38) together.

*(e)* Install the drum (48) over the six spacers (24). Install the adapter elbow (34) onto axle shaft (35). Install the capscrew (31), lockwasher (32), and nut (33).

*(f)* Position the bevel gear (30) on disc (22) and secure with six capscrews (29).

*(g)* Position the ring gear (27) and six spacers (28) on the disc (22), and secure with six screws (25) and lockwashers (26).

*(h)* Install the disc (22) onto the six spacers (24) by securing with six studs (23), lockwashers (77), and nuts (78).

*(i)* Put a new O-ring (21) between the adapter elbow (34) and the swivel joint (20), and fasten the elbow and swivel joint together with six capscrews (18) and lockwashers (19).

*(j)* Attach a suitable hoist to the drum (48) and raise drum to position over frame. Install spacers (16 and 17) between bearing and collar (45) and frame (15). Install two capscrews (7), flat washers (8), lockwashers (9), and nuts (10). Next, install two capscrews (11), flat washers (12), lockwashers (13), and nuts (14).

*(k)* Position spacer (4) and pinion and bearing assembly (5) onto frame (6), and secure with two

capscrews (1), lockwashers (2), and flatwashers (3). Ensure that pinion-on-pinion bearing assembly (5) mates properly with bevel gear (30).

*e.* *Installation.* Install hose reel (para 5-23).

**8-6. Hose Reel - 1¼ and 1½-inch (Fig. 8-8)**

*a.* *Removal.* Remove hose reel (para 5-24).

*b.* *Disassembly* (Fig. 8-8).

*(1) Drum Assembly.*

*(a)* Remove two capscrews (1), lockwashers (2), and flatwashers (3) securing the pinion bearing assembly (hose reel lock) (5) to the frame (6). Remove the pinion bearing assembly (5) and the guard (4).

*(b)* Attach a suitable hoist to drum (26), and remove the two capscrews (7), flatwashers (8), lockwashers (9), and nuts (10). Then remove two capscrews (11), flatwashers (12), lockwashers (13), and nuts (14). Lift drum assembly from front and rear frame (6 and 15) and place on a suitable work bench. Be sure to keep the two spacers (16) with the drum assembly.

*(c)* Loosen set screw on bearing collar. Use punch to rotate collar clockwise to release bearing and collar from shaft.

*(d)* Remove four nuts (73), lockwashers (74), and studs (18) from disc (20). Remove six capscrews (21), lockwashers (22), and nuts (23). Remove collar (24).

*(e)* Remove drum (26).

**NOTE**

**Take note of how many thrust washers (25) are used between spacers and disc.**

*(f)* Remove four nuts (75), lockwashers (76), studs (27), thrust washers (25), and spacers (28).

*(g)* Unscrew adapter elbow (29) from the swing joint (30).

*(h)* Remove capscrew (31), lockwasher (32), and nut (33). Remove axle shaft (34). Remove four capscrews (35) and lockwashers (36) securing outlet elbow (37) to adapter elbow (29). Remove outlet elbow (37) and O-ring (38). Discard O-ring.

*(i)* Loosen set screw (39) and remove swing joint (30) from the support collar (40).

*(j)* Remove six capscrews (41), lockwashers (43), and nuts (42). Remove support collar (40).

(k) Remove six screws (44) and lockwashers (45) securing the ring gear (46) to the disc (47). Remove six spacers (48) and ring gear (46). Remove six capscrews (49) and shakeproof washers (50), and remove bevel gear (51),

(2) *Removal of Motor.*

**NOTE**

**Hose reel need not be removed from cabinet to remove motor.**

(a) Remove four machine screws (52) and then remove cover (53). Tag and disconnect electrical leads from motor (54) at the motor junction box (55) and remove all conduit connections (para 4-27). Disconnect the motor junction box from bushing (56) and bushing from motor.

**WARNING**

**Do not remove nipple from motor. Nipple is packed in place with plaster. If nipple is removed, motor will no longer be explosion proof. Failure to follow this warning may result in serious injury or death to personnel.**

(b) Remove four screws (57), lockwashers (58), and nuts (59) securing motor (54) to mounting bracket (60) and to frame (6). Remove motor (54).

(c) Loosen set screw (61) and remove pinion gear (62).

(3) *Removal of Terminal Board in Motor Junction Box.*

(a) If motor was not previously removed under paragraph (2) above, remove the four machine screws (52) and cover (53). Remove two leads with terminals (11, fig. 8-7) that come from motor at the terminal board. Tag and disconnect all electrical leads from the terminal board (63) (para 4-27). Remove the two capacitors (64).

(b) Remove the two machine screws (65) securing the terminal board (63) to the junction box and remove the terminal board.

(4) *Disassembly of Frame.*

**NOTE**

**Drum and motor must be removed before complete disassembly of frame can be accomplished.**

(a) Remove four capscrews (66), washers (67), lockwashers (68), and nuts (69). Remove two tie rods (70).

(b) Remove eight capscrews (71), lockwashers (68), and nuts (69). Remove two side angles (72).

Legend for figure 8-8:

- |                              |                            |
|------------------------------|----------------------------|
| 1. Capscrew (2)              | 39. Set screw              |
| 2. Lockwasher (2)            | 40. Support collar         |
| 3. Flatwasher (2)            | 41. Capscrew (6)           |
| 4. Pinion guard              | 42. Nut (6)                |
| 5. Pinion bearing assembly   | 43. Lockwashers (6)        |
| 6. Front frame               | 44. Screw (6)              |
| 7. Capscrew (2)              | 45. Lockwasher (6)         |
| 8. Flatwasher (2)            | 46. Ring gear              |
| 9. Lockwasher (2)            | 47. Disc                   |
| 10. Nut (2)                  | 48. Spacer (6)             |
| 11. Capscrew (2)             | 49. Screw (6)              |
| 12. Flatwasher (2)           | 50. Shakeproof washers (6) |
| 13. Lockwasher (2)           | 51. Bevel gear             |
| 14. Nut (2)                  | 52. Machine screw (4)      |
| 15. Rear frame               | 53. Cover                  |
| 16. Spacer                   | 54. Motor                  |
| 17. Bearing and collar       | 55. Motor junction box     |
| 18. Stud (4)                 | 56. Bushing                |
| 19. Set screw                | 57. Screw (4)              |
| 20. Disc                     | 58. Lockwasher (4)         |
| 21. Capscrew (6)             | 59. Nut (4)                |
| 22. Lockwasher (6)           | 60. Mounting bracket       |
| 23. Nut (6)                  | 61. Set screw              |
| 24. Collar                   | 62. Pinion gear            |
| 25. Thrust washer (as req'd) | 63. Terminal board         |
| 26. Drum                     | 64. Capacitor (2)          |
| 27. Stud (4)                 | 65. Machine screw (2)      |
| 28. Spacer (4)               | 66. Capscrew (4)           |
| 29. Adapter elbow            | 67. Washer (4)             |
| 30. Swing joint              | 68. Lockwasher (12)        |
| 31. Capscrew                 | 69. Nut (4)                |
| 32. Lockwasher               | 70. Tie rod (2)            |
| 33. Nut                      | 71. Capscrew (8)           |
| 34. Axle shaft               | 72. Side angle (2)         |
| 35. Capscrew (4)             | 73. Nut (6)                |
| 36. Lockwasher (4)           | 74. Lockwasher (6)         |
| 37. Outlet elbow             | 75. Nut (6)                |
| 38. O-ring                   | 76. Lockwasher (6)         |

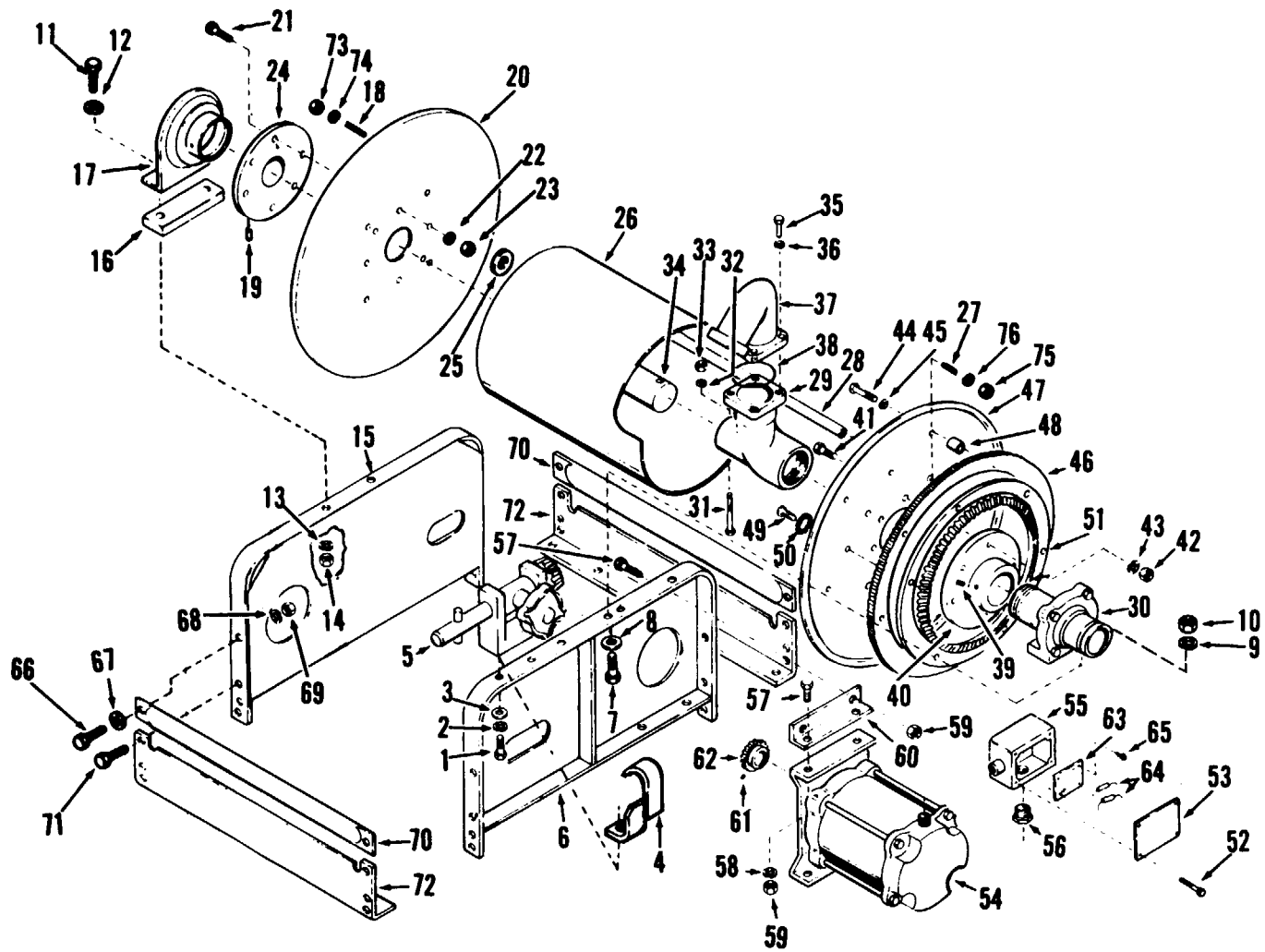

Figure 8-8. 1/4 and 1/2-inch Hose Reel.

c. *Cleaning, Inspection, and Repair.*

**WARNING**

**Dry cleaning solvent P-D-680 is toxic and flammable. Always wear protective goggles and gloves, and use only in a well-ventilated area. Avoid contact with skin, eyes, and clothes, and DO NOT breathe vapors. DO NOT use near open flame or excessive heat. The solvent's flash point is 100°F-138°F (38°C-59°C). if you become dizzy while using cleaning solvent, immediately get fresh air and medical help. If solvent contacts eyes, immediately wash your eyes with water and get medical aid.**

(1) Clean all metal parts with dry cleaning solvent (item 11, Appendix E) and dry thoroughly.

(2) Inspect gears for worn, damaged, or missing teeth. Replace gears if damaged.

d. *Assembly (Fig. 8-8).*

(1) *Assembly of Frame.*

(a) Position one side angle (72) onto the two frames (6 and 15). Secure in place with four capscrews (71), lockwashers (68), and nuts (69).

(b) Install other side angle (72) onto the two frames (6 and 15). Secure in place with four capscrews (71), lockwashers (68), and nuts (69).

(c) Install both tie rods (70) onto the frames (6 and 15). Secure with four capscrews (66), washers (67), lockwashers (68), and nuts (69).

(2) *Installation of Terminal Board in Motor Junction Box.*

(a) Install the two nuts (2, fig. 8-7) on studs (1) on the terminal board (3). Install the middle capscrew (4) and one nut (5) onto the terminal board.

(b) Position the terminal board in the motor junction box (6). Install screw (7), but do not tighten. Install capacitors (8 and 9) onto screw (7). Be sure capacitors are installed with marking in position shown in figure 8-7. Tighten screw (7).

(c) Install lead with terminal (11, fig. 8-7) from motor along with capacitor lead to terminal board. Secure with screw (10). Install motor lead and capacitor lead to screw (4). Install second nut (5) and tighten.

(d) Reconnect hose reel wiring in motor junction box (para 4-27).

(e) Replace motor junction box cover (53, fig. 8-8) and secure in place with four machine screws (52).

(3) *Installation of Motor (Fig. 8-8).*

**NOTE**

**Be sure pinion gear teeth mesh properly with the ring gear teeth.**

(a) Install pinion gear (62) on motor shaft. Tighten set screw (61).

(b) Position motor between mounting bracket (60, fig. 8-8) and frame (6). Install four capscrews (57), lockwashers (58), and nuts (59).

(c) Install bushing (56) into junction box (55). Install assembly onto motor.

(d) Connect the two motor leads to the terminal board (63) in the junction box. Connect leads to terminal board and install conduit (para 4-27). Replace cover (53) and secure with four machine screws (52).

(4) *Drum Assembly.*

(a) Attach bevel gear (51, fig. 8-8) to disc (47) with six screws (49) and shakeproof washers (50). Attach ring gear (46) to disc (47). Use six spacers (48) between the ring gear and disc, and secure with six screws (44) and lockwashers (45).

(b) Position the support collar (40) on disc (47), and secure with six capscrews (41), lockwashers (43), and nuts (42).

(c) Install swing joint (30) through support collar (40) and tighten set screw (39).

(d) Install a new O-ring (38) between adapter elbow (29) and outlet elbow (37). Secure the outlet elbow to the adapter elbow with four capscrews (35) and lockwashers (36).

(e) Screw adapter elbow (29) onto swing joint (30).

(f) Install axle shaft (34) to adapter elbow (29) with capscrew (31), lockwasher (32), and nut (33).

(g) Install four spacers (28) onto disc (47) using four studs, lockwashers (76), and nuts (75).

(h) Install drum (26) over the four spacers (28), lockwashers (76), and nuts (75).



(i) Install original number of thrust washers (25) over spacer (28).

(j) Install collar (24) onto disc (20) using six cap screws (21), lockwashers (22), and nuts (23).

(k) Install disc (24) over axle shaft (34), and attach disc to four spacers (28) with four studs (18), lockwashers (74), and nuts (73). Tighten set screw (19).

(l) Install bearing and collar (17) onto axle shaft (34). Lock onto shaft by rotating collar counterclockwise. Tighten set screw.

(m) Attach a suitable hoist to the drum (26) and raise drum into position over frame. install spacer (16) between bearing and collar (17), and frame (15). Install two cap screws (11), flatwashers (12), lockwashers (13), and nuts (14). Next, install two cap screws (7), flatwashers (8), lockwashers (9), and nuts (10).

(n) Position pinion guard (4) and pinion bearing assembly (5) onto frame (6), and secure to frame with two cap screws (1), lockwashers (2), and flatwashers (3). Be sure pinion-on-pinion bearing assembly (5) mates properly with bevel gear (51).

e. *Installation.* Install hose reel (para 5-24).

### Section IV. METERS

#### 8-7. Meter (M970 and M970A1)

a. *General.* The meters on the M969, M969A1, M970, and M970A1 *semitrailers* are not to be repaired except for replacement of the meter head seal on the M970 and M970A1 meter.

#### b. Meter Head Seal Replacement.

(1) Cut security wire (fig. 8-9) and remove four cap screws holding register head to meter body. Remove register.

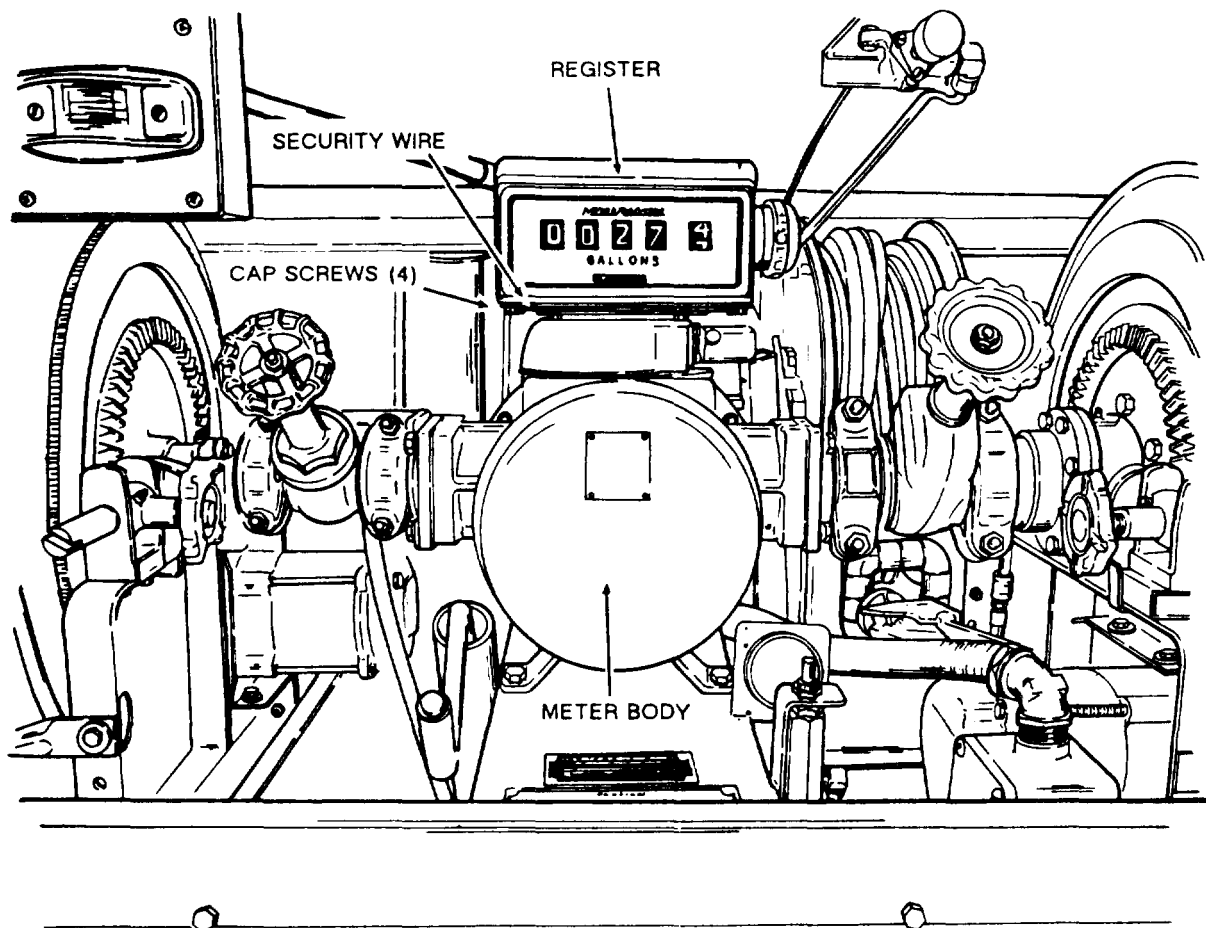
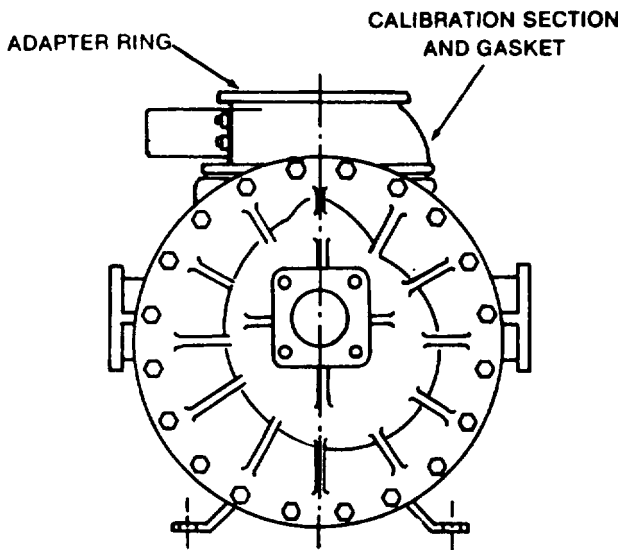

Figure 8-9. Meter (A1970 and M970A1).

TA100173

(2) Remove four flat head screws securing adapter ring (fig. 8-10) 10 calibration section. Remove adapter ring.

(3) Remove four filister head screws and lift off calibration section along with the bottom rubber gasket.



TA100174

Figure 8-10. Meter With Register Removed.

(4) Remove small snap ring (8, fig. 8-11) from drive shaft. Remove two screws (9) and insert them into the two tapped holes in the retainer plate (5). The two screws will lift the retainer plate from the counter base plate (1), exposing O-ring (3).

(5) Remove O-ring (3) and replace.

(6) If shims (6) and washers (7) were dislodged from retainer plate (5), install them into the retainer plate.

(7) Remove the two screws (9) from the retainer plate. Position gasket (4) and retainer plate (5) onto counter baseplate (1), and attach with two screws (9).

(8) Install snap ring (8) onto the shaft.

(9) Position the calibration section (fig. 8-10) and gasket over the counter base plate (1, fig. 8-11). Fasten the calibration section with four filister head screws.

(10) Attach adapter ring (fig. 8-10) to the calibration section with four flat head screws.

(11) Position register (fig. 8-9) onto adapter plate and secure with four capscrews. Install new security wire.

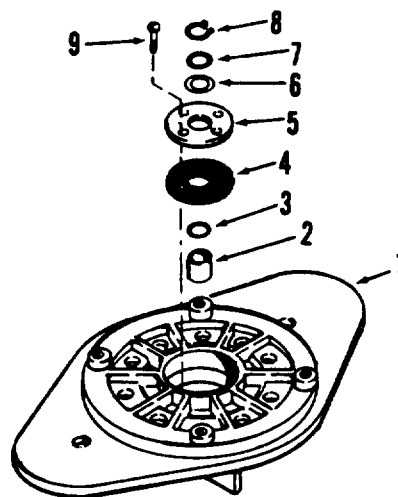

- |                       |               |
|-----------------------|---------------|
| 1. Counter base plate | 6. Shims (AR) |
| 2. Gland spacer       | 7. Washer     |
| 3. O-ring             | 8. Snap ring  |
| 4. Gasket             | 9. Screw (2)  |
| 5. Retainer plate     |               |

TA113214

Figure 8-11. Replacing O-ring in Metez.

## Section V. EMERGENCY VALVE VENT AND FLOAT ASSEMBLY

### 8-8. Emergency Valve Vent

a. *General.* The emergency valve vent is attached to the top of the tank near the manhole cover. It is connected to the emergency valve by an actuating rod (fig. 8-12). Before the vent can be removed or adjusted, the fuel must be completely drained from the semitrailer tank and the interior of the tank must be purged. For draining and purging instructions, refer to Section XX, Chapter 4.

b. *Removal (Fig. 8-12).*

(1) Make sure emergency valve is closed.

(2) Remove manhole cover to aid in removal of the emergency valve vent (para 4-59).

#### WARNING

**Ladder has narrow tread. Use care when climbing.**

#### NOTE

**When vent is being removed the connector and tube will separate from the vent. Hold the tube while the vent is being removed to keep it from falling into tank, then remove the tube.**

(3) Remove eight capscrews that fasten the vent to the top of the tank. Remove the vent and gasket.

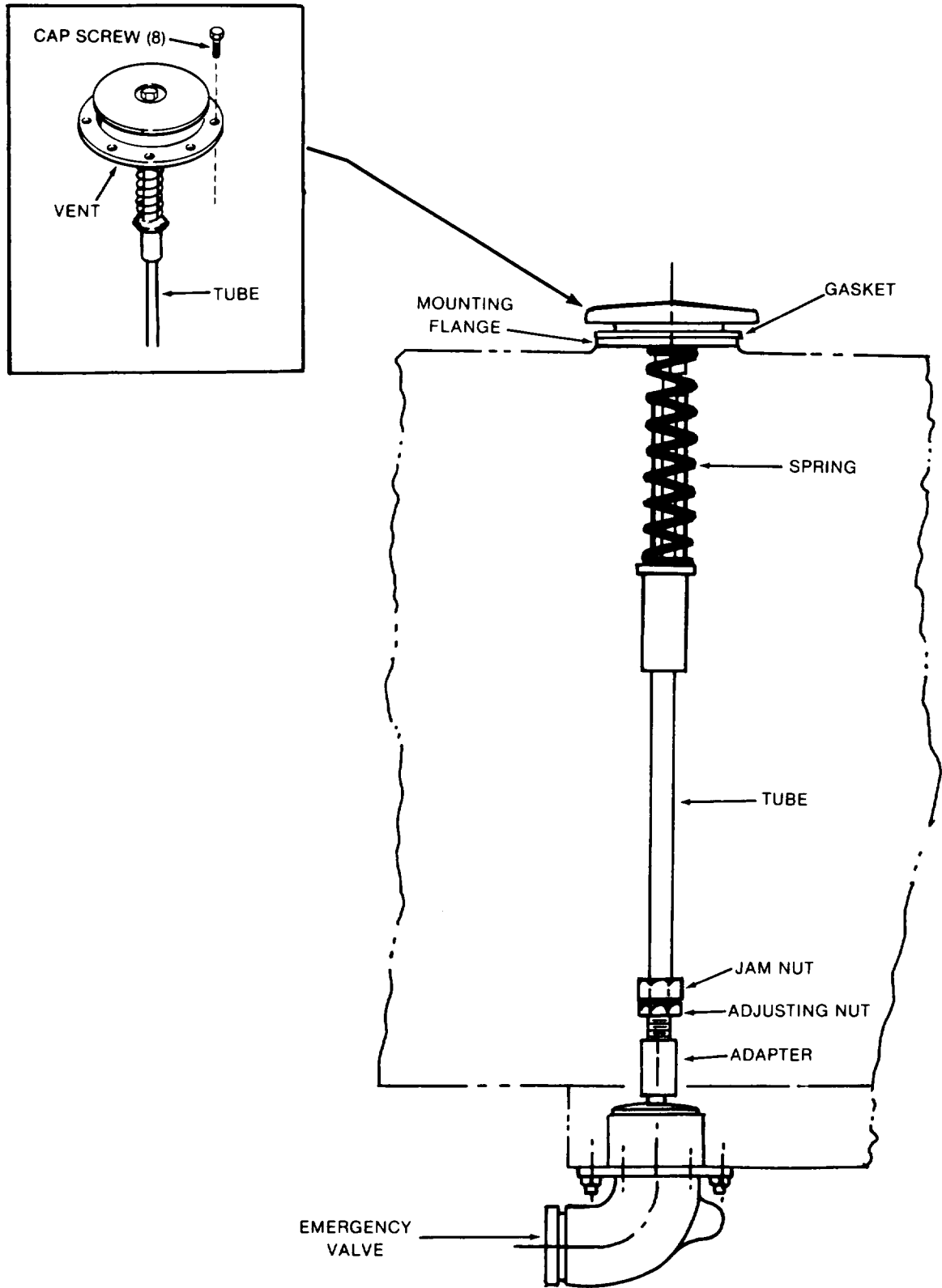

Figure 8-12. Emergency Valve Vent Installation.

TA113215

**WARNING**

**Dry cleaning solvent P-D-680 is toxic and flammable. Always wear protective goggles and gloves, and use only in a well-ventilated area. Avoid contact with skin, eyes, and clothes, and DO NOT breathe vapors. DO NOT use near open flame or excessive heat. The solvent's flash point is 100°F-136°F (38°C-59°C). If you become dizzy while using cleaning solvent, immediately get fresh air and medical help. If solvent contacts eyes, immediately wash your eyes with water and get medical aid.**

c. *Cleaning and Inspection.* Clean vent assembly with dry cleaning solvent (item 11, Appendix E). Inspect O-ring under vent cap for physical damage. Inspect for broken or damaged spring. Inspect gasket for physical damage. Discard if damaged.

d. *Installation.*

(1) Install tube and connector into adapter. Hold in place by hand.

(2) Position gasket on top of vent mounting flange on top of tank. Lower vent into place on top of tank, aligning the connector with the vent. Hold complete assembly in place and install eight capscrews.

e. *Adjustment.*

(1) Emergency valve vent must be open whenever the emergency valve is opened.

(2) If vent does not open, adjust vent as follows:

**WARNING**

**Do not climb into tank unless interior of tank has been drained and purged and an explosive meter check indicates it is safe to do so. Adequate forced air ventilation or self-contained breathing apparatus must be used. Person entering tank must have an attached lifeline. An observer must be stationed at the manhole opening so that assistance may be summoned in the event of an emergency. Failure to follow this warning may result in serious injury or death to personnel.**

(a) Adjustment must be done from inside tank.

(b) Close the emergency valve.

(c) Loosen jam nut and turn adjusting nut (fig. 8-12) until tube has 1/8-inch vertical travel.

(d) Tighten jam nut.

(e) Open emergency valve and ensure that emergency valve vent also opens.

**8-9. Float Assembly**

**WARNING**

**Do not climb into tank unless Interior of tank has been drained and purged and an explosive meter check indicates it is safe to do so. Adequate forced air ventilation or self-contained breathing apparatus must be used. Person entering tank must have an attached lifeline. An observer must be stationed at the manhole opening so that assistance may be summoned in the event of an emergency. Failure to follow this warning may result in serious injury or death to personnel.**

a. *General.*

(1) The float assembly is located inside the semitrailer tank. It can only be removed by a person from inside the tank.

(2) Before the float assembly can be removed, the fuel must be drained from the semitrailer tank and the interior must be purged. For draining and purging instructions refer to Section XX, Chapter 4.

b. *Float Replacement (Fig. 8-13).*

(1) Disconnect the two tubes (1 and 2) from the elbows (3 and 4). Be sure not to lose the two inserts (5 and 6).

(2) Remove capscrew (7), flatwasher (8), and float valve (9).

(3) Remove bushing (10), elbow (3), bushing (11), elbow (4), and bushing (12).

(4) Replace bushing (10), elbow (3), bushing (11), elbow (4), and bushing (12) on the float valve (9).

(5) Install float valve (9) onto the mounting bracket with capscrew (7) and washer (8).

(6) Reconnect the two tubes (1 and 2) to elbows (3 and 4). Be sure inserts (5 and 6) are in place in tubes.

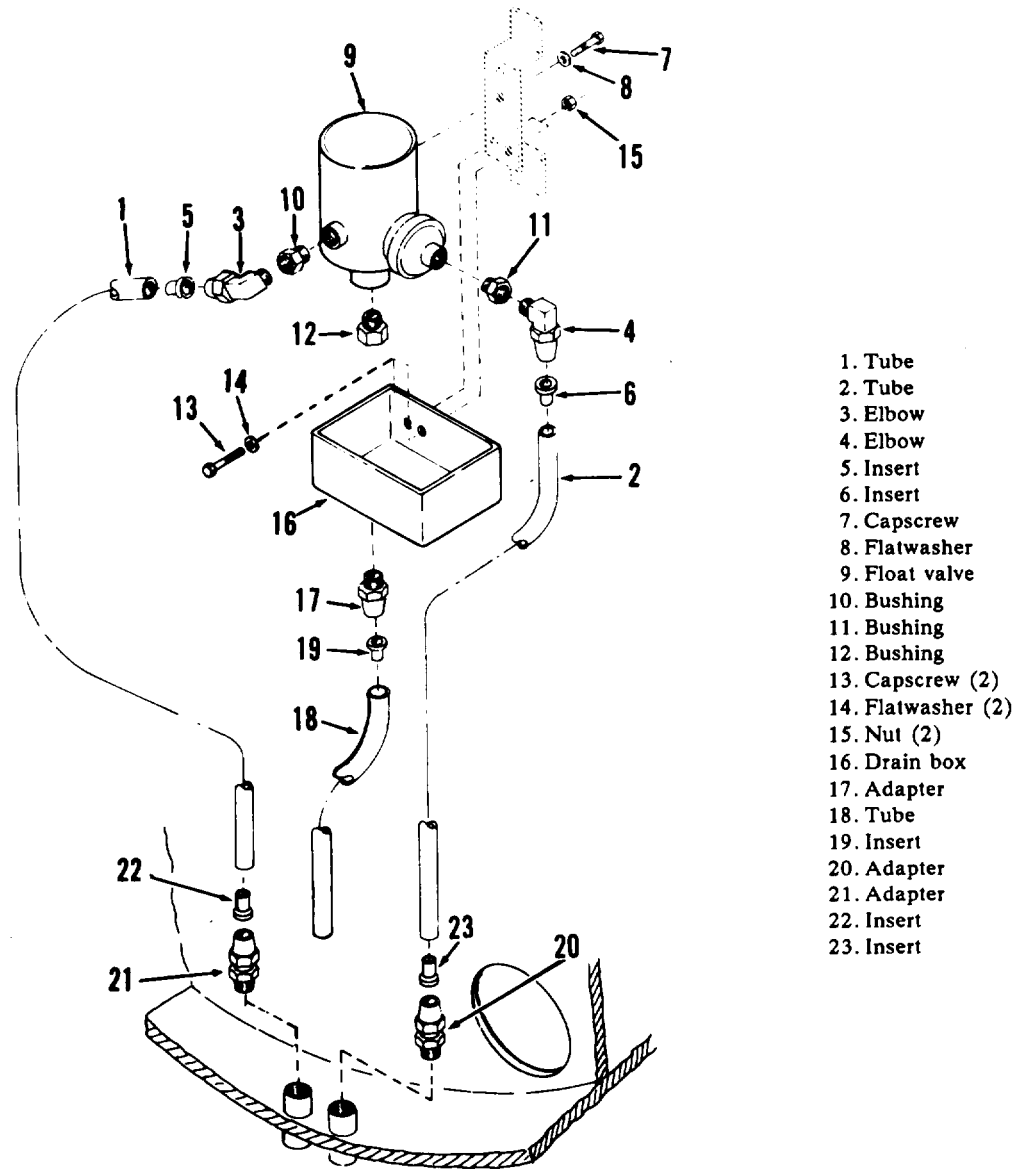

- 1. Tube
- 2. Tube
- 3. Elbow
- 4. Elbow
- 5. Insert
- 6. Insert
- 7. Capscrew
- 8. Flatwasher
- 9. Float valve
- 10. Bushing
- 11. Bushing
- 12. Bushing
- 13. Capscrew (2)
- 14. Flatwasher (2)
- 15. Nut (2)
- 16. Drain box
- 17. Adapter
- 18. Tube
- 19. Insert
- 20. Adapter
- 21. Adapter
- 22. Insert
- 23. Insert

TA113217

**Figure 8-13. Float Installation.**

*c. Replacement of Drain Box.*

(1) Remove two capserews (13), flatwashers (14), and nuts (15). Remove drain box (16).

(2) Disconnect tube (18) from adapter (17). Be sure not to lose insert (19).

(3) Remove adapter (17) from the drain box.

*d. Replacement of Tubing.* Remove tubing from fittings (para 4-91).

Section VI. VALVES

8-10. Gate Valve (Fig. 8-14)

NOTE

It is not necessary to remove valve to repair.

- a. *Removal.* Remove valve (para 4-85).
- b. *Disassembly.*

(1) Secure valve.

(2) Remove eight capscrews (1), lockwashers (2), and nuts (3). Lift upper hand wheel assembly from valve body. Remove gasket (4), and clean mating edges of valve body and hand wheel assembly.

(3) Loosen packing nut (5) and turn hand wheel counterclockwise. This will force the spring (6), gland (7), and packing (8) free of the bonnet (9).

(4) Secure stem (10), and remove nut (11) and hand wheel (12).

- c. *Cleaning and Inspection.*

**WARNING**

**Dry cleaning solvent P-D-680 is toxic and flammable. Always wear protective goggles and gloves, and use only in a well-ventilated area. Avoid contact with skin, eyes, and clothes, and DO NOT breathe vapors. DO NOT use near open flame or excessive heat. The solvent's flash point is 100°F-138°F (38°C-59°C). If you become dizzy while using cleaning solvent, immediately get fresh air and medical help. If solvent contacts eyes, immediately wash your eyes with water and get medical aid.**

(1) Clean metal parts with dry cleaning solvent (item 11, Appendix E) and dry thoroughly.

(2) Inspect for cracks and pitting.

(3) If disc assembly (13) or its mating surfaces in valve body are pitted or scored, replace entire valve.

- d. *Assembly.*

(1) Place packing (8), gland (7), spring (6), and packing nut (5) on stem (10). Tighten packing nut two full turns only.

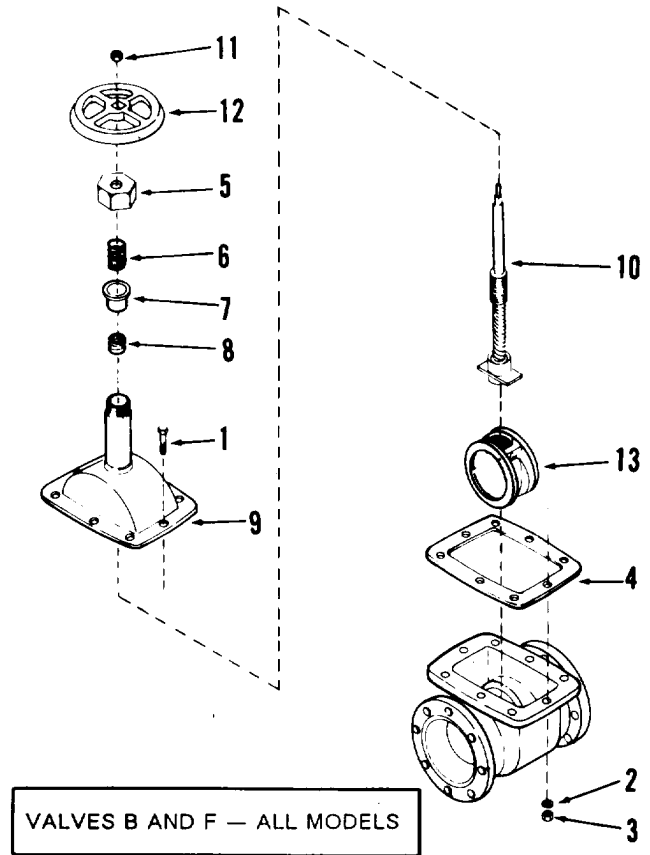

- |                   |                   |
|-------------------|-------------------|
| 1. Capscrew (8)   | 8. Packing        |
| 2. Lockwasher (8) | 9. Bonnet         |
| 3. Nut (8)        | 10. Stem          |
| 4. Gasket         | 11. Nut           |
| 5. Packing nut    | 12. Hand wheel    |
| 6. Spring         | 13. Disc assembly |
| 7. Gland          |                   |

TA502307

Figure 8-14. Gate Valve,

(2) Place gasket (4) in position, and install bonnet assembly on body. Ensure that disc assembly (13) is at a right angle to pipe opening. Install eight capscrews (1), lockwashers (2), and nuts (3).

(3) Place hand wheel (12) and nut (11) on stem. Turn hand wheel clockwise to seat valve.

- e. *Installation.* Install gate valve (para 4-85).

**8-11. Gate Valve, M970 and M970A1 (Fig. 8-15)**

**NOTE**

**It is not necessary to remove valve to replace packings.**

- a. *Removal.* Remove valve (para 4-85).
- b. *Disassembly.*
  - (1) Secure valve.
  - (2) Loosen packing nut (1). Turn hand wheel (2) counterclockwise to force packing (3) and packing gland (4) free from the valve body (5). Remove nut (6) and hand wheel (2).

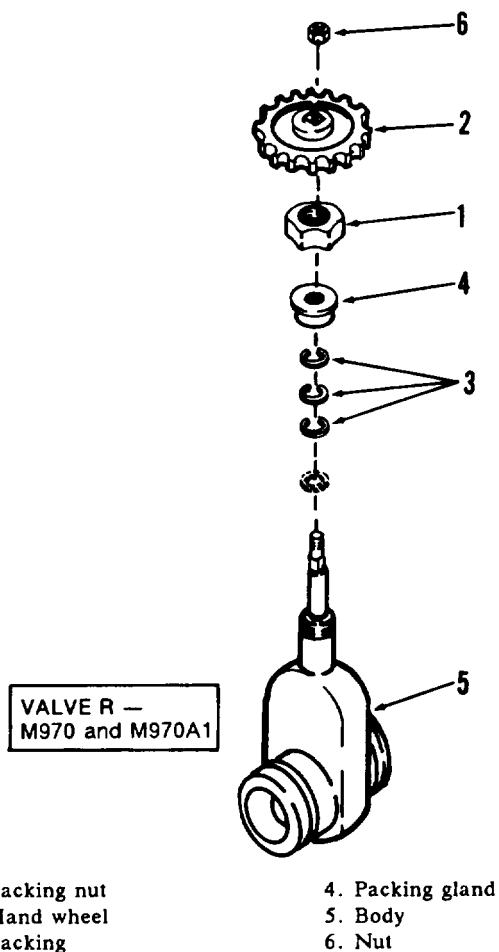

**Figure 8-15. Gate Valve.**

TA502308

- c. *Cleaning and Inspection.*

**WARNING**

**Dry cleaning solvent P-D-680 is toxic and flammable. Always wear protective goggles and gloves, and use only in a well-ventilated area. Avoid contact with skin, eyes, and clothes, and DO NOT breathe vapors. DO NOT use near open flame or excessive heat. The solvent's flash point is 100°F-138°F (38°C-59°C). If you become dizzy while using cleaning solvent, immediately get fresh air and medical help. If solvent contacts eyes, immediately wash your eyes with water and get medical aid.**

- (1) Clean all metal parts with dry cleaning solvent (item 11, Appendix E).
- (2) Inspect for cracks. If valve is removed from the semitrailer, check sealing surfaces for pitting or scoring. If any damage is noticed, replace valve.

- d. *Assembly.*

- (1) Install new packing (3). Install packing gland (4) and packing nut (1). Tighten nut two full turns.
- (2) Install hand wheel (2) and nut (6). Tighten nut.

- e. *Installation.* Install valve (para 4-85).

**8-12. Gate Valve, M970 and M970A1 (Fig. 8-16)**

**NOTE**

**It is not necessary to remove valve to replace packings.**

- a. *Removal.* Remove valve (para 4-85).
- b. *Disassembly.*
  - (1) Secure valve.
  - (2) Loosen packing nut (1). Turn hand wheel (2) counterclockwise to force packing (3) and packing gland (4) free from the bonnet (5). Remove nut (6) and hand wheel (2).

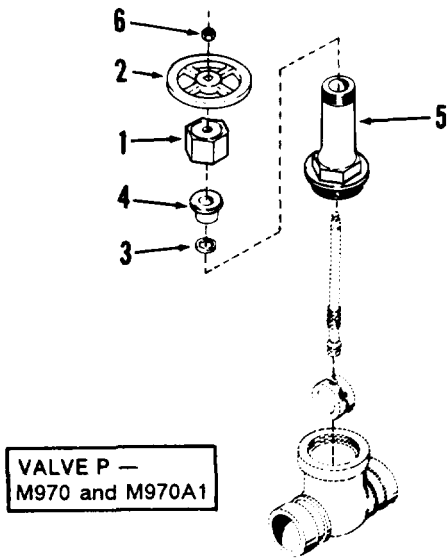

- |                |                  |
|----------------|------------------|
| 1. Packing nut | 4. Packing gland |
| 2. Hand wheel  | 5. Body          |
| 3. Packing     | 6. Nut           |

TA502309

**Figure 8-16. Gate Valve.**

*c. Cleaning and Inspection.*

**WARNING**

**Dry cleaning solvent P-D-680 is toxic and flammable. Always wear protective goggles and gloves, and use only in a well-ventilated area. Avoid contact with skin, eyes, and clothes, and DO NOT breathe vapors. DO NOT use near open flame or excessive heat. The solvent's flash point is 100°F-138°F (38°C-59°C). If you become dizzy while using cleaning solvent, immediately get fresh air and medical help. If solvent contacts eyes, immediately wash your eyes with water and get medical aid.**

(1) Clean all metal parts with dry cleaning solvent (item 11, Appendix E).

(2) Inspect for cracks. If valve is removed from the semitrailer, check sealing surfaces for pitting or scoring. If any damage is noticed, replace valve.

*d. Assembly.*

(1) Install new packing (3). Install packing gland (4) and packing nut (1). Tighten nut two full turns.

(2) Install hand wheel (2) and nut (6). Tighten nut.

*e. Installation.* Install valve (para 4-85).

**8-13. Butterfly Valve (Fig. 8-17)**

*a. Removal.* Remove valve (para 4-85).

*b. Disassembly.*

(1) Secure valve.

(2) Remove cotter pin (1) from top pin (2). Remove top pin and handle (3). Clip (4) may remain in handle.

(3) Remove two socket head screws (5) and stop plate (6).

(4) Remove top stem (7), split bearing (8), two packings (9), and seal (10).

(5) Remove spring pin (11). Remove bottom stem (12) and O-ring (13).

(6) Remove bearing (16) from bottom stem (12).

(7) Remove disc (14) and sleeve (15).

*c. Cleaning and Inspection.*

**WARNING**

**Dry cleaning solvent P-D-680 is toxic and flammable. Always wear protective goggles and gloves, and use only in a well-ventilated area. Avoid contact with skin, eyes, and clothes, and DO NOT breathe vapors. DO NOT use near open flame or excessive heat. The solvent's flash point is 100°F-138°F (38°C-59°C). If you become dizzy while using cleaning solvent, immediately get fresh air and medical help. If solvent contacts eyes, immediately wash your eyes with water and get medical aid.**

(1) Clean all metal parts in dry cleaning solvent (item 11, Appendix E).

(2) Inspect for cracks, scoring, and pitting.

(3) Replace any damaged part.

*d. Assembly.*

(1) Install bearing (16) on bottom stem (12).

(2) Replace sleeve (15) and disc (14).



VALVE G — M967 and M967A1  
 VALVES G, M, P, and R — M969 and M969A1  
 VALVES G and M — M970 and M970A1

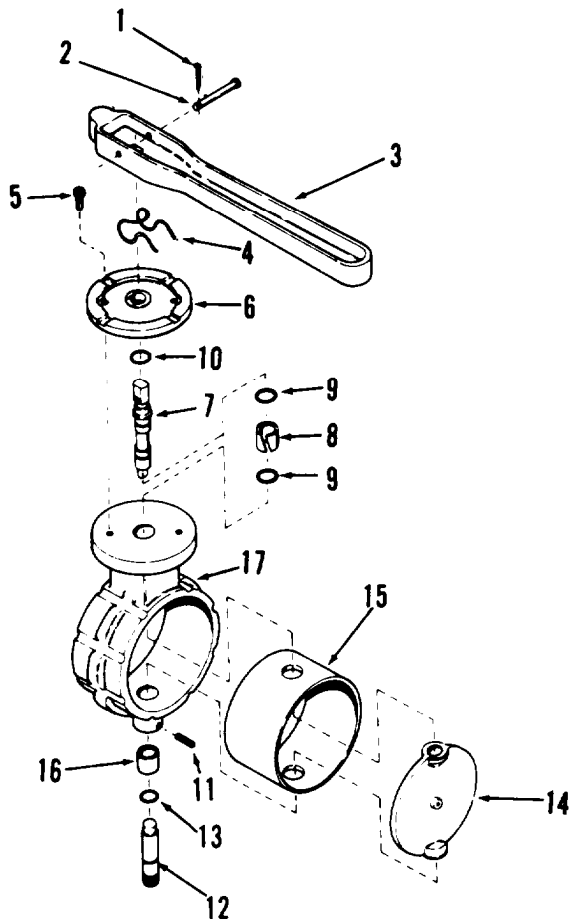

- |                           |                 |
|---------------------------|-----------------|
| 1. Cotter pin             | 10. Seal        |
| 2. Top pin                | 11. Spring pin  |
| 3. Handle                 | 12. Bottom stem |
| 4. Clip                   | 13. O-ring      |
| 5. Socket head screws (2) | 14. Disc        |
| 6. Stop plate             | 15. Sleeve      |
| 7. Top stem               | 16. Bearing     |
| 8. Split bearing          | 17. Body        |
| 9. Packing (2)            |                 |

TA502310

Figure 8-17. Butterfly Valve.

(3) Replace bottom stem (12) and O-ring (13).

**NOTE**

Ensure that bottom stem (12) mates up with disc (14).

(4) Replace spring pin (11).

**NOTE**

Ensure that top stem (7) mates up with disc (14).

(5) Replace top stem (7), split bearing (8), and packings (9).

(6) Install seal (10) and stop plate (6) with two socket head screws (5).

(7) Position handle (3) on top stem (7), aligning holes for installation of top pin (2) and cotter pin (1). Ensure that clip (4) is in position.

e. *Installation.* Install valve (para 4-85).

**8-14. Check Valve (M967, M967A1, M969, and M969A1) (Fig. 8-18)**

a. *Removal.* Remove valve (para 4-85).

b. *Disassembly.*

(1) Secure valve.

(2) Remove retaining ring (1), cap (2), and O-ring (3).

(3) Remove the two plugs (4) and pin (5) from body (6).

(4) Lift disc assembly (7) out of valve body.

(5) Secure lever (8) and remove retaining ring (10), washer (9), disc (11), packing (12), and bushing (13).

c. *Cleaning and Inspection.*

**WARNING**

**Dry cleaning solvent P-D-680 is toxic and flammable. Always wear protective goggles and gloves, and use only in a well-ventilated area. Avoid contact with skin, eyes, and clothes, and DO NOT breathe vapors. DO NOT use near open flame or excessive heat. The solvent's flash point is 100°F-138°F (38°C-59°C). If you become dizzy while using cleaning solvent, immediately get fresh air and medical help. If solvent contacts eyes, immediately wash your eyes with water and get medical aid.**

(1) Clean all metal parts with a dry cleaning solvent (item 11, Appendix E).

(2) Inspect for cracks, pitting, and scoring.

(3) Replace any damaged part.

*d. Assembly.*

(1) Place packing (12) on disc (11) and assemble with lever (8). Lock disc in place with washer (9) and retaining ring (10).

(2) Push bushing (13) into lever and position disc assembly (7) into valve body (6). Install pin (5) into body, aligning it with disc assembly (7). Install the two plugs (4).

(3) Position O-ring (3) on cover (2) and place into valve body (6). Secure with retaining ring (1).

*e. Installation.* Install valve (para 4-85):

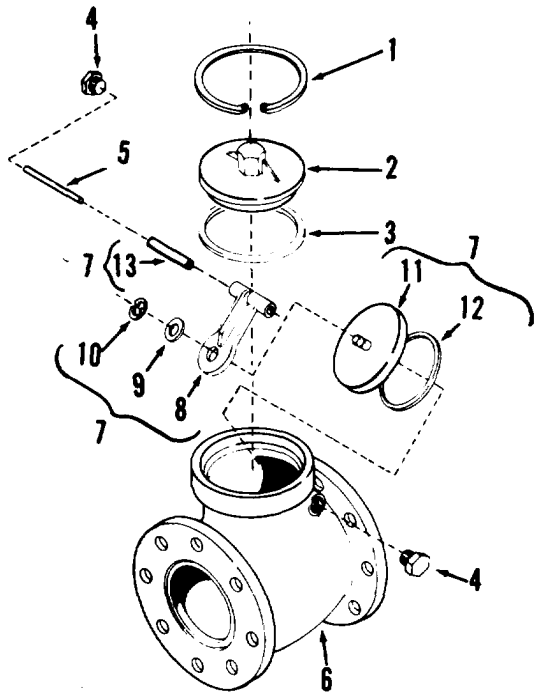

- |                   |                    |
|-------------------|--------------------|
| 1. Retaining ring | 8. Lever           |
| 2. Cap            | 9. Washer          |
| 3. O-ring         | 10. Retaining ring |
| 4. Plug (2)       | 11. Disc           |
| 5. Pin            | 12. Packing        |
| 6. Body           | 13. Bushing        |
| 7. Disc assembly  |                    |

TA502311

**Figure 8-18. Check Valve (M967, M967A1, M969, and M969A1).**

**8-15. Angle Valve (M969, M969A1, M970 and M970A1) (Fig. 8-19)**

**NOTE**

**It is not necessary to remove valve to repair.**

*a. Removal.* Remove valve (para 4-85).

*b. Disassembly.*

(1) Secure valve.

(2) Loosen packing nut (1), and turn hand wheel (2) counterclockwise to force packing (3) and packing gland (4) free of bonnet (5).

(3) Remove nut (6) and hand wheel (2).

(4) Remove packing nut (1), spring (13), packing gland (4), and packing (3).

(5) Unscrew bonnet (5) from body (7).

(6) Unscrew disc nut (8) from the stem (9). Remove disc seat (10) from disc holder (11).

*c. Cleaning and Inspection,*

**WARNING**

**Dry cleaning solvent P-D-680 is toxic and flammable. Always wear protective goggles and gloves, and use only in a well-ventilated area. Avoid contact with skin, eyes, and clothes, and DO NOT breathe vapors. DO NOT use near open flame or excessive heat. The solvent's flash point is 100°F-138°F (38°C-59°C). If you become dizzy while using cleaning solvent, immediately get fresh air and medical help. If solvent contacts eyes, immediately wash your eyes with water and get medical aid.**

(1) Wash all metal parts in dry cleaning solvent (item 11, Appendix E) and dry thoroughly.

(2) Inspect for cracks and pitting.

*d. Assembly.*

(1) Install disc ring (12), disc holder (11), disc seat (10), and disc nut (8) to stem (9). Tighten disc nut.

(2) Place the assembled stem and disc assembly inside body (7). Install bonnet (5) and tighten.

(3) Install packing (3), packing gland (4), spring (13), and packing nut (1). Tighten packing nut two full turns.

- (4) Replace hand wheel (2) and nut (6) onto stem (9).
- (9).
- e. *Installation.* Install valve (para 4-85).

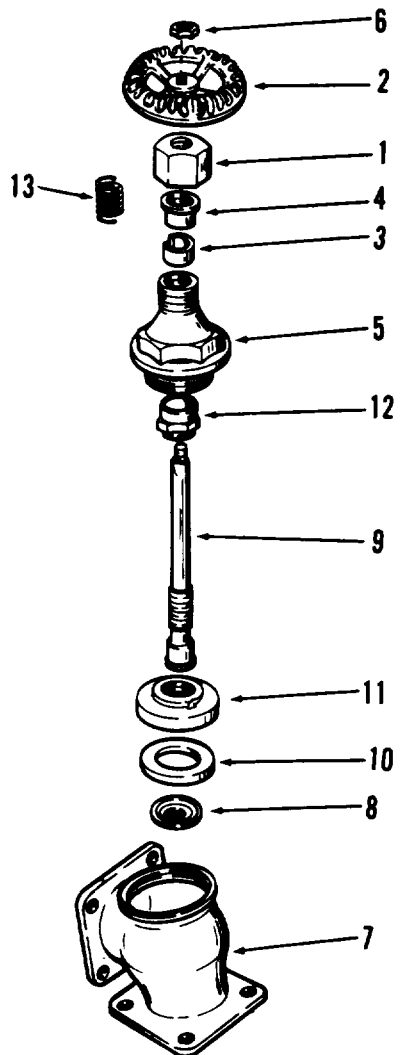

- |                  |                 |
|------------------|-----------------|
| 1. Packing nut   | 8. Disc nut     |
| 2. Hand wheel    | 9. Stem         |
| 3. Packing       | 10. Disc seat   |
| 4. Packing gland | 11. Disc holder |
| 5. Bonnet        | 12. Disc ring   |
| 6. Nut           | 13. Spring      |
| 7. Body          |                 |

TA113222

**Figure 8-19. Angle Valve (M969, M969A1, M970, and M970A1).**

**8-16. Pump Bypass Valve (M970 and M970A1) (Fig. 8-20)**

- a. *Removal.* Remove valve (para 4-85).
- b. *Disassembly.*
- (1) Secure valve.

- (2) Remove cover (1), gasket (2), spring (3), and plunger (4). Remove insert (5).

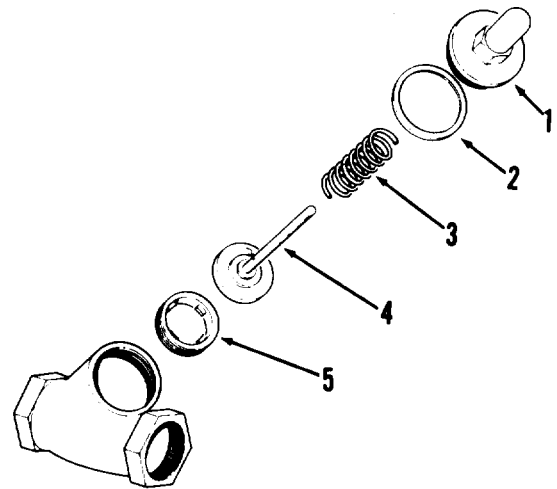

- |           |            |
|-----------|------------|
| 1. Cover  | 4. Plunger |
| 2. Gasket | 5. Insert  |
| 3. Spring |            |

TA113223

**Figure 8-20. Pump Bypass Valve (M970 and M970A1).**

- c. *Cleaning and Inspection.*

**WARNING**

Dry cleaning solvent P-D-680 is toxic and flammable. Always wear protective goggles and gloves, and use only in a well-ventilated area. Avoid contact with skin, eyes, and clothes, and DO NOT breathe vapors. DO NOT use near open flame or excessive heat. The solvent's flash point is 100°F-138°F (38°C-59°C). If you become dizzy while using cleaning solvent, immediately get fresh air and medical help. If solvent contacts eyes, immediately wash your eyes with water and get medical aid.

- (1) Clean all metal parts in dry cleaning solvent (item 11, Appendix E).
- (2) Inspect valve for cracks. Check insert (5) and plunger (4) for scoring and pitting.
- (3) Replace any damaged parts.

- d. *Assembly.*

- (1) Install insert (5). Install plunger (4), spring (3), gasket (2), and cover (1).
- e. *Installation.* Install valve (para 4-85).

**8-17. Manifold Drain Valve (Fig. 8-21)**

**NOTE**

It is not necessary to remove valve to replace packing.

a. *Removal.* Remove valve (para 4-90).

b. *Disassembly.*

(1) Secure valve.

(2) Loosen packing nut (1) and turn hand wheel (2) counterclockwise to force packing (3) and packing gland (4) free of bonnet (5).

(3) Remove nut (6) and hand wheel (2).

(4) Remove packing nut (1), packing gland (4), and packing (3).

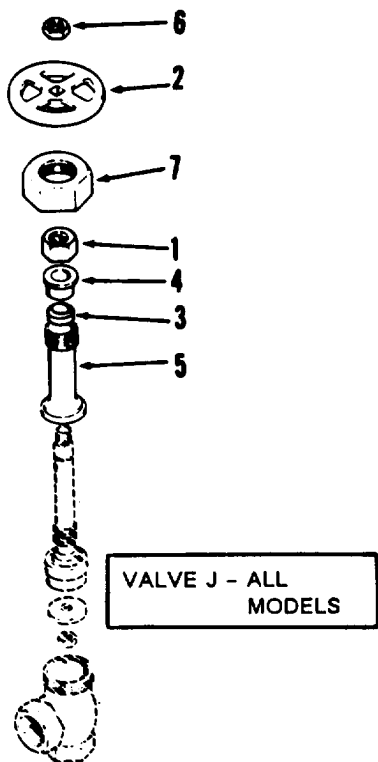

- |                  |               |
|------------------|---------------|
| 1. Packing nut   | 5. Bonnet     |
| 2. Hand wheel    | 6. Nut        |
| 3. Packing gland | 7. Bonnet nut |
| 4. Packing       |               |

TA502312

**Figure 8-21. Manifold Drain Valve.**

c. *Cleaning and Inspection.*

**WARNING**

**Dry cleaning solvent P-D-680 is toxic and flammable. Always wear protective goggles and gloves, and use only in a well-ventilated area. Avoid contact with skin, eyes, and clothes, and DO NOT breathe vapors. DO NOT use near open flame or excessive heat. The solvent's flash point is 100°F-138°F (38°C-59°C). If you become dizzy while using cleaning solvent, immediately get fresh air and medical help. If solvent contacts eyes, immediately wash your eyes with water and get medical aid.**

(1) Clean all metal parts in dry cleaning solvent (item 11, Appendix E) and dry thoroughly.

(2) Inspect for cracks in valve.

d. *Assembly.*

(1) Install packing (3), packing gland (4), and packing nut (1). Tighten packing nut two full turns.

(2) Assemble hand wheel (2) and nut (6).

e. *Installation.* Install valve (para 4-90).

**8-18. Filter/Separator Automatic Drain Valve (M969, M969A1, M970, and M970A1) (Fig. 8-22)**

a. *Test.* A leak from the drain valve is an indication that either the diaphragm valve or the separator control valve is leaking. To determine which valve is leaking:

(1) Disconnect the tube fitting at rear of diaphragm assembly (fig. 8-22).

(2) Dispense fuel through filter/separator and visually watch for leakage.

(3) If leakage continues, the problem is in the diaphragm valve and could be:

(a) *Dirt under seat.*

(b) *Damaged O-rings.*

(c) *Stem hanging up.* If the stem is hung up, a moderate blow with a rawhide mallet to the bottom cap of the diaphragm valve might free the sticking stem.

(d) *Vent plugged.* If vent is plugged, clean hole in vent plug (fig. 8-22) with a .020- to .030-inch diameter wire.

(4) If leaking stops, this is an indication that the problem is in the separator control valve.

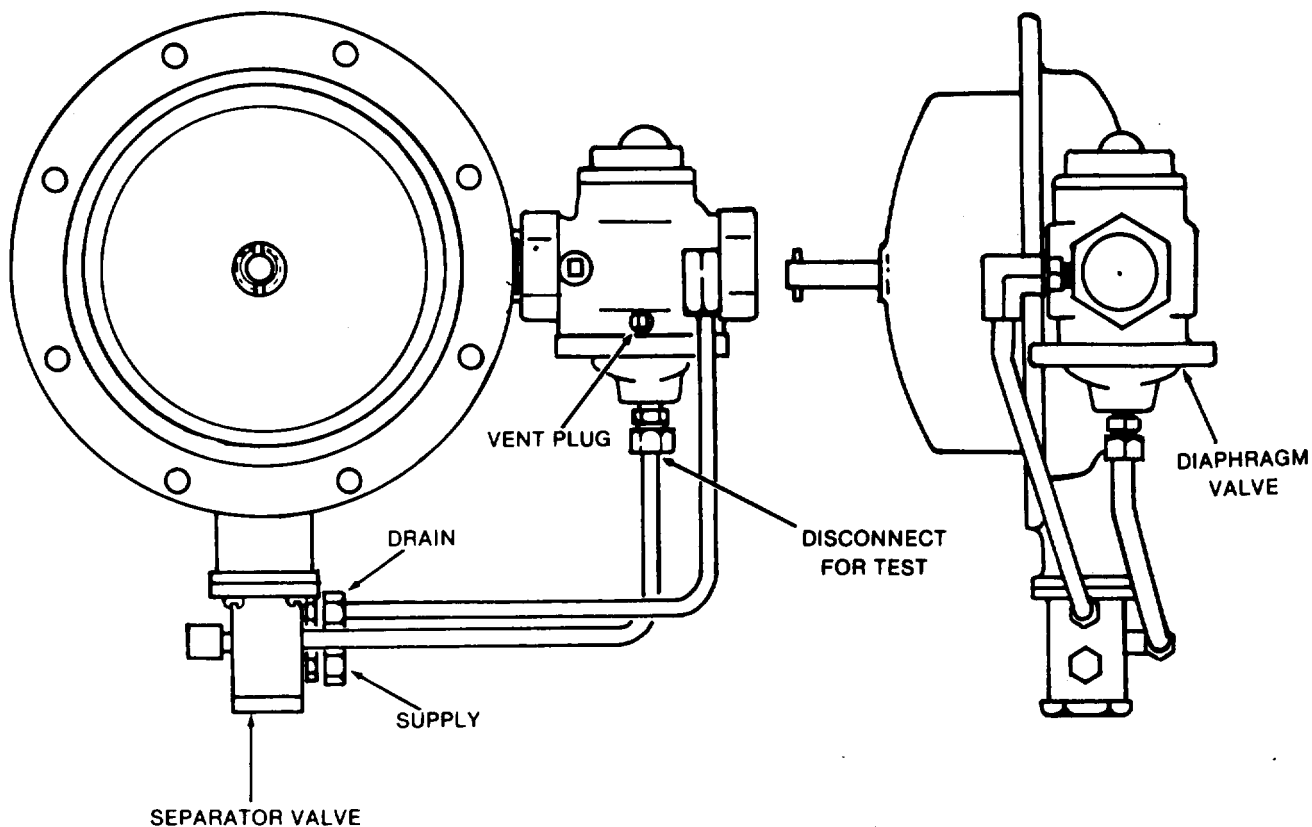

TA113225

**Figure 8-22. Filter/Separator/Drain Valve (M969, M969A1, M970, and M970A1).**

*b. Diaphragm Valve.*

*(1) Removal.*

*(a)* Disconnect the two lines (fig.8-22) from the diaphragm valve.

*(b)* Unscrew the diaphragm valve from the nipple at the separator valve.

*(2) Disassembly (Fig. 8-23).*

*(a)* Remove eight screws (1, fig. 8-23) and remove cover (2).

*(b)* Unscrew bottom cover (3) from diaphragm valve. Remove cover (3), O-ring (4), and spring (5).

*(c)* Remove nut (6) from top of diaphragm (7). Remove two washers (8 and 9), O-ring (10), and diaphragm (7).

*(d)* Remove stem (11) with items (13 and 17) attached, through bottom of valve body.

*(e)* Remove nut (13), retainer (14), O-ring (15), O-ring (16), and washer (17).

*(f)* Unscrew bearing retainer (18) and remove O-rings (19 and 20).

*(g)* Remove seat (12) from body (21).

**CAUTION**

**Use caution when removing bottom cover (3). Bottom cover is spring loaded.**

(3) *Cleaning and Inspection.*

**WARNING**

**Dry cleaning solvent P-D-680 is toxic and flammable. Always wear protective goggles and gloves, and use only in a well-ventilated area. Avoid contact with skin, eyes, and clothes, and DO NOT breathe vapors. DO NOT use near open flame or excessive heat. The solvent's flash point is 100°F-138°F (38°C-59°C). If you become dizzy while using cleaning solvent, immediately get fresh air and medical help. If solvent contacts eyes, immediately wash your eyes with water and get medical aid.**

(a) Clean all metal parts in dry cleaning solvent (item 11, Appendix E) and dry thoroughly.

(b) Inspect all parts for damage. If parts other than O-rings and the diaphragm need replacement, replace entire valve.

(4) *Assembly (Fig. 8-23).*

(a) Screw seat (12) into body (21),

(b) Install O-ring (19) onto bearing retainer (18). Install O-ring (20) into bearing retainer.

(c) Install washer (17), O-ring (16), O-ring (15), and retainer (14) onto stem (11). Retain these parts with nut (13).

(d) Install the assembled stem through bottom of body (21). Install washer (9), O-ring (10), diaphragm (7), washer (8), and nut (6).

(e) Install spring (5) into body (21). Screw cover (3) with O-ring (4) into body.

(f) Install cover (2) and secure with eight screws (1).

(5) *Installation.*

(a) Screw diaphragm valve onto nipple at the separator valve.

(b) Connect the two lines to the diaphragm valve.

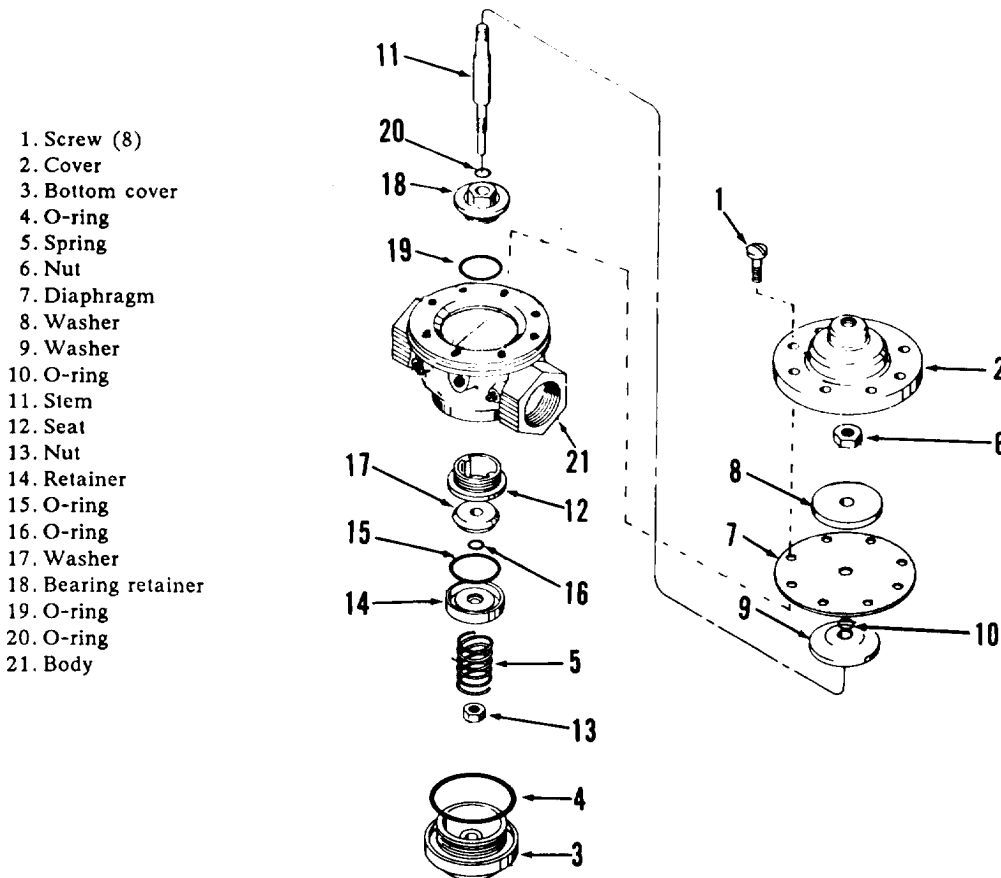

Figure 8-23. Diaphragm Valve.

TA113226

c. *Separator Valve (Fig. 8-24).*

**NOTE**

It Is not necessary to remove valve to disassemble.

(1) *Removal.* Remove valve from filter/separator (para 4-83).

(2) *Disassembly.*

(a) Remove cover (1) from the body (10). Remove O-ring (2).

**NOTE**

**Spring (3), retainer (5), and disc (6) are loose items. Ensure that they do not become lost.**

(b) Remove spring (3), retainer (5), and disc (6). Bearing (4) is pressed into cover (1).

(c) Unscrew seat (7) from body (10). Remove O-ring (9). Bearing seat (8) is pressed into seat (7).

(d) Disconnect tubes (fig. 8-22) from body (10).

(e) Remove four screws (11). Remove body (10) and O-ring (12). Remove O-ring (13).

(3) *Cleaning and Inspection.*

**WARNING**

**Dry cleaning solvent P-D-680 is toxic and flammable. Always wear protective goggles and gloves, and use only in a well-ventilated area. Avoid contact with skin, eyes, and clothes, and DO NOT breathe vapors. DO NOT use near open flame or excessive heat. The solvent's flash point is 100°F-138°F (38°C-59°C). If you become dizzy while using cleaning solvent, immediately get fresh air and medical help. If solvent contacts eyes, immediately wash your eyes with water and get medical aid.**

(a) Clean all metal parts in dry cleaning solvent (item 11, Appendix E) and dry thoroughly.

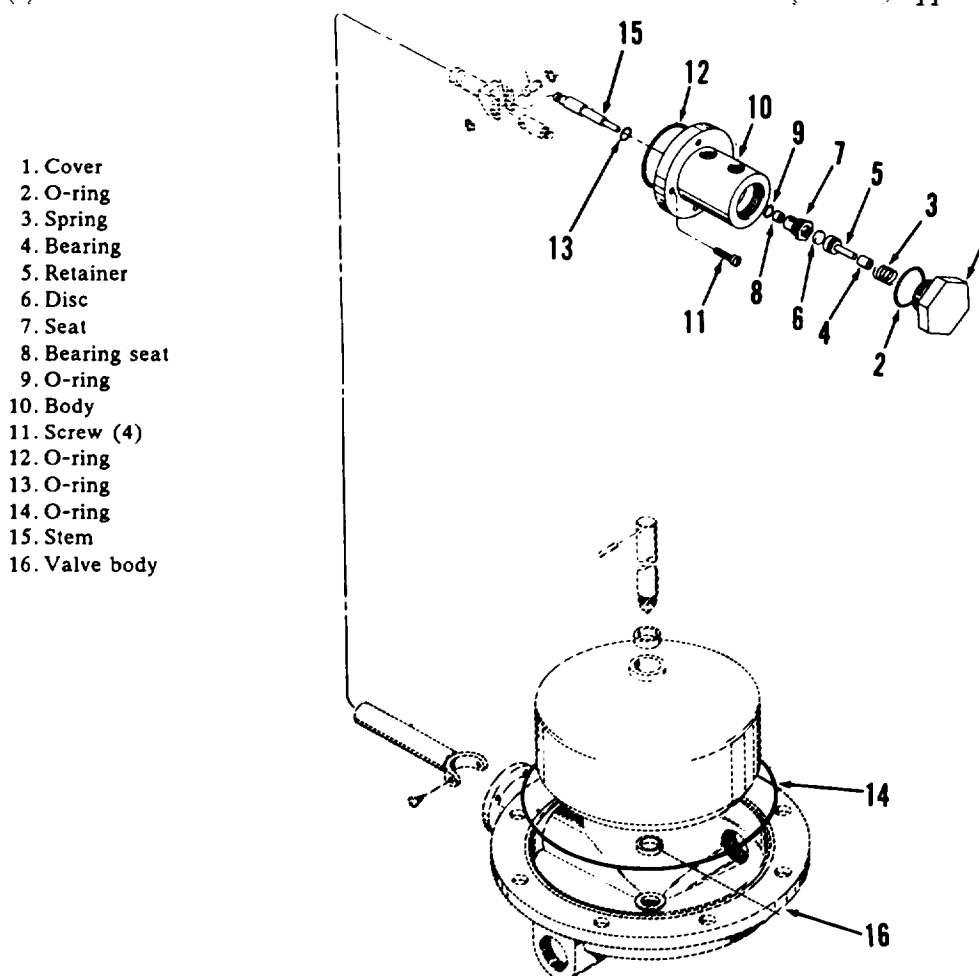

- 1. Cover
- 2. O-ring
- 3. Spring
- 4. Bearing
- 5. Retainer
- 6. Disc
- 7. Seat
- 8. Bearing seat
- 9. O-ring
- 10. Body
- 11. Screw (4)
- 12. O-ring
- 13. O-ring
- 14. O-ring
- 15. Stem
- 16. Valve body

**Figure 8-24. Separator Valve.**

TA113227

(b) Inspect all parts for damage. If parts other than O-rings and the disc (6) need replacement, replace entire valve.

(4) Assembly.

(a) Install O-ring (13) onto stem (15), then install O-ring (12) into groove on body (10). Install O-ring and body onto the valve body (16). Secure with four screws (11).

(b) Install O-ring (9) into seat (7) and screw seat (7) into body (10).

(c) Install disc (6), retainer (5), and spring (3) into body (10).

(d) Install O-ring (2) onto cover (1) and screw cover into the body.

(e) Connect the tubes (fig. 8-22) to the body (10).

(f) Install O-ring (14) into groove on valve body (16).

(5) *Installation.* Install valve to filter/separator (para 4-83).

**8-19. Filter/Separator Manual Drain Valve (M969, M969A1, M970, and M970A1) (Fig. 8-25)**

a. *Removal.* Remove valve (para 4-83).

b. *Disassembly.*

(1) Secure valve.

(2) Loosen packing nut (1). Turn hand wheel (2) counterclockwise to force packing gland (3) and packing (4) free from bonnet (5).

(3) Remove nut (6) and hand wheel (2).

(4) Remove nut (7) to free bonnet (5) from valve body (8).

(5) Remove nut (9). Pry washer (10) free from stem (11).

c. *Cleaning and Inspection.*

**WARNING**

**Dry cleaning solvent P-D-680 is toxic and flammable. Always wear protective goggles and gloves, and use only in a well-ventilated area. Avoid contact with skin, eyes, and clothes, and DO NOT breathe vapors. DO**

**NOT use near open flame or excessive heat. The solvent's flash point is 100°F-138°F (38°C-59°C). If you become dizzy while using cleaning solvent, immediately get fresh air and medical help. If solvent contacts eyes, immediately wash your eyes with water and get medical aid.**

(1) Clean all metal parts with dry cleaning solvent (item 11, Appendix E).

(2) Inspect for cracks in valve body and bonnet.

(3) Inspect valve seat in body for pitting and scoring.

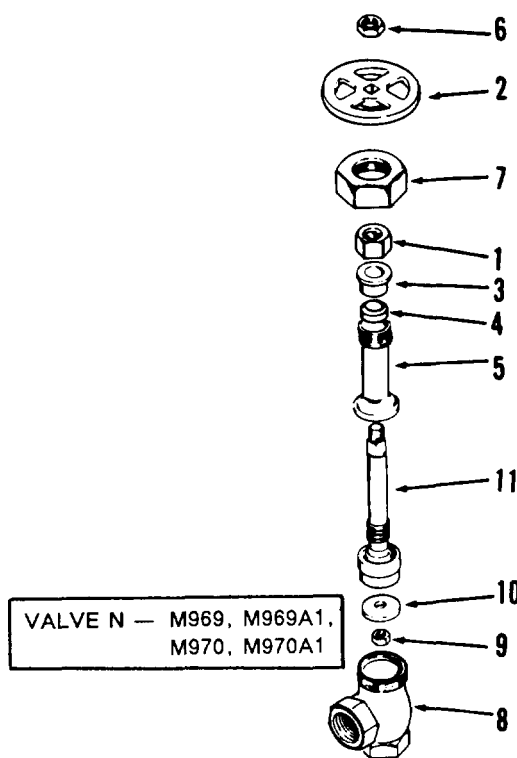

- |                  |               |
|------------------|---------------|
| 1. Packing nut   | 7. Bonnet nut |
| 2. Hand wheel    | 8. Valve body |
| 3. Packing gland | 9. Nut        |
| 4. Packing       | 10. Washer    |
| 5. Bonnet        | 11. Stem      |
| 6. Nut           |               |

TA113228

**Figure 8-25. Manual Drain Valve.**

d. *Assembly.*

(1) Install washer (10) and nut (9).

(2) Fit bonnet (5) into valve body (8), and install nut (7).



(3) Install packing (4), packing gland (3), and packing nut (1).

(4) Install hand wheel (2) and nut (6).

e. *Installation.* Install valve (para 4-83).

**8-20. Emergency Valve (Fig. 8-26)**

a. *Removal.* Remove emergency valve from bottom of tank sump (para 4-85).

b. *Disassembly.*

(1) Remove lever (1) from stem (7) by loosening nut (3) and screw (2), and pulling lever from shaft.

(2) Unscrew stuffing box nut (4), and remove O-ring (5) and two packing glands (6) from stuffing box nut (4).

(3) Pull stem (7) from body (8). Cam (9) will fall into body. Remove cam.

(4) Loosen set screw (10) and remove adapter (11).

(5) Loosen three set screws (12) and remove bonnet (13).

(6) Remove spring (14), then pull stem (15), along with assembled disc assembly, out through top of valve.

(7) Remove nut (16), washer (17), retaining plate (18), plunger disc (19), and disc holder (20) from stem (15).

c. *Cleaning and Inspection.*

**WARNING**

**Dry cleaning solvent P-D-680 is toxic and flammable. Always wear protective goggles and gloves, and use only in a well-ventilated area. Avoid contact with skin, eyes, and clothes, and DO NOT breathe vapors. DO NOT use near open flame or excessive heat. The solvent's flash point is 100°F-138°F (38°C-59°C). If you become dizzy while using cleaning solvent, immediately get fresh air and medical help. If solvent contacts eyes, immediately wash your eyes with water and get medical aid.**

(1) Clean all metal parts with dry cleaning solvent (item 11, Appendix E) and dry thoroughly.

(2) Inspect all parts for damage and replace any damaged part.

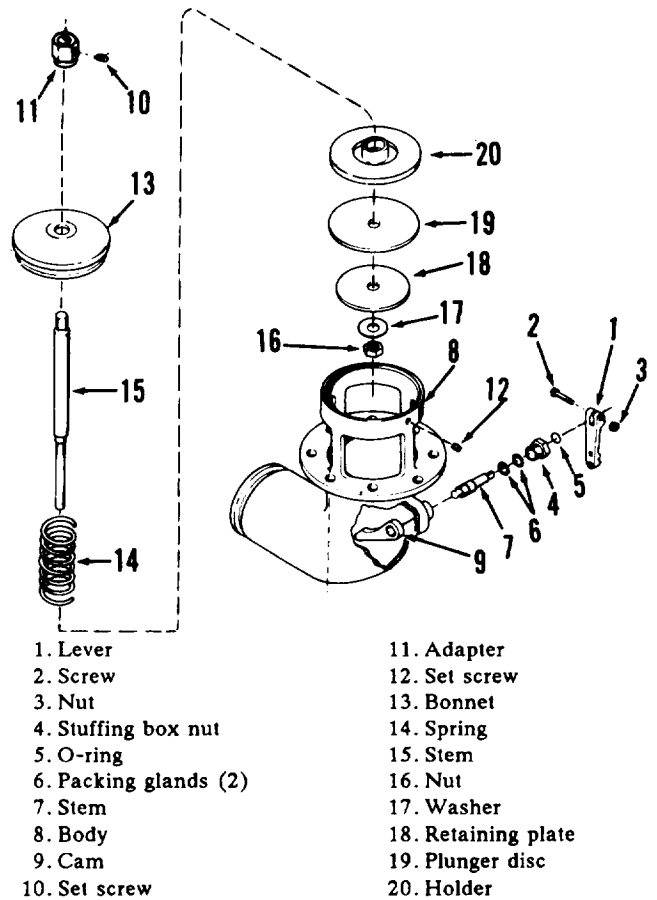

**Figure 8-26. Emergency Valve.**

TA502313

d. *Assembly.*

(1) Position cam (9) inside the body (8), and install stem (7) into body.

(2) Install O-ring (5) and two packing glands (6) into stuffing box nut (4). Install stuffing box nut by sliding over stem (7), and screw into body.

(3) Install lever (1) onto stem (7), and tighten screw (2) and nut (3).

(4) Install disc holder (20), plunger disc (19), retaining plate (18), and washer (17) onto stem (15). Install and tighten nut (16).

(5) Install assembled stem and disc into top of body. Install spring (14).

(6) Install bonnet (13) and secure in place by tightening three set screws (12).

(7) Install adapter (11), and tighten set screw (10) to secure adapter to stem (15).

e. *Installation.* Install emergency valve to tank sump (para 4-85).

**8-21. Deadman Control Valve (M970 and M970A1) (Fig. 8-27)**

a. *Removal and Disassembly.*

(1) Pull hose reel hoses out far enough to remove deadman control.

(2) Remove two screws and nuts (fig. 8-27) on the deadman control to free the valve assembly.

(3) Disconnect the two hoses from the valve assembly and remove valve.

(4) Drive out roll pin securing the lever to the handle guard and remove lever.

b. *Assembly and Installation.*

(1) Aline holes in lever (fig. 8-27) and handle guard. Drive in roll pin to secure lever.

(2) Thread red hose through opening in handle guard (fig. 5-27), and attach to OUT port of valve assembly. Attach green hose to IN port of valve assembly.

(3) Replace valve assembly in handle guard of deadman control. Secure with two screws and nuts.

(4) Pull hoses to release latch on hose reel and rewind the hoses.

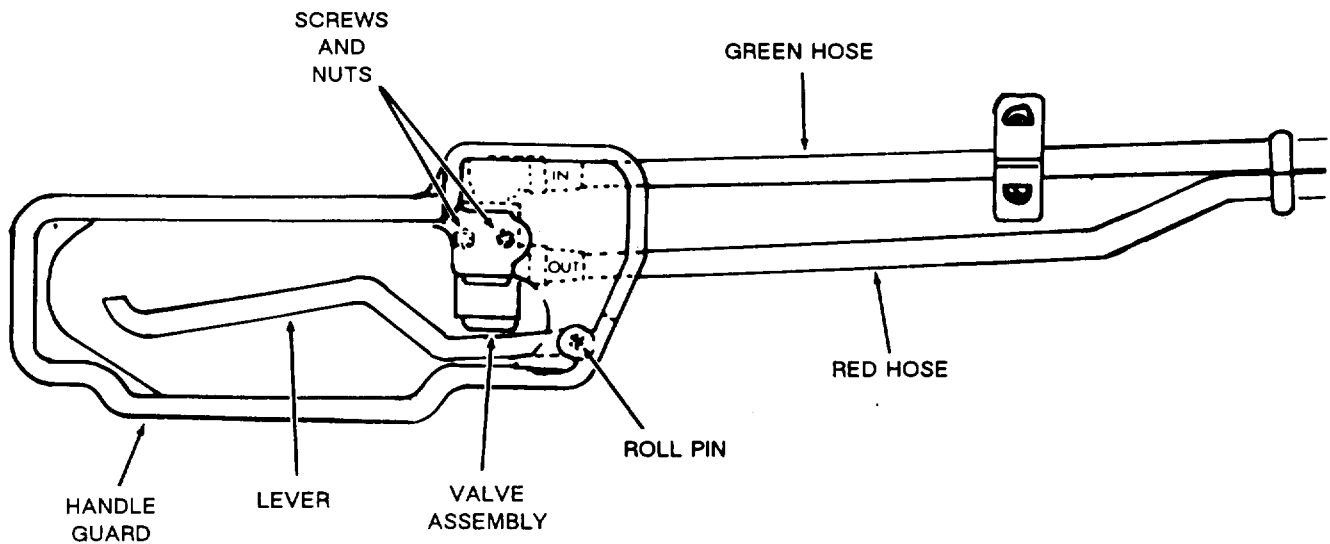

*Figure 8-27. Deadman Control.*

TA113230

## Section VII. NOZZLES AND COUPLINGS

**8-22. Vehicle Nozzle (M969 and M969A1)**

- a. *Removal.* Remove nozzle (para 4-96).
- b. *Disassembly (Fig. 8-28).*
- (1) Place nozzle assembly on a clean work area.
  - (2) Unscrew ground wire from nozzle handle.
  - (3) Disconnect the chain for the cap from the nozzle.
  - (4) Unscrew the spout from nozzle handle and remove the strainer.
- c. *Cleaning and Inspection.*

**WARNING**

**Dry cleaning solvent P-D-680 is toxic and flammable. Always wear protective goggles and gloves, and use only in a well-ventilated area. Avoid contact with skin, eyes, and clothes, and DO NOT breathe vapors. DO NOT use near open flame or excessive heat. The solvent's flash point is 100°F-138°F (38°C-59°C). If you become dizzy while using cleaning solvent, immediately get fresh air and medical help. If solvent contacts eyes, immediately wash your eyes with water and get medical aid.**

(1) Clean the strainer, spout, and nozzle handle with dry cleaning solvent (item 11, Appendix E) and dry thoroughly.

(2) Check spout, screen, rubber cap and chain, and ground wire and connector for damage.

(3) Replace any damaged part.

d. *Assembly (Fig. 8-28).*

(1) Insert strainer into spout and screw spout onto handle.

(2) Reconnect cap and chain to the nozzle.

(3) Screw ground wire into nozzle handle.

e. *Installation.* Install vehicle nozzle to hose (para 4-96).

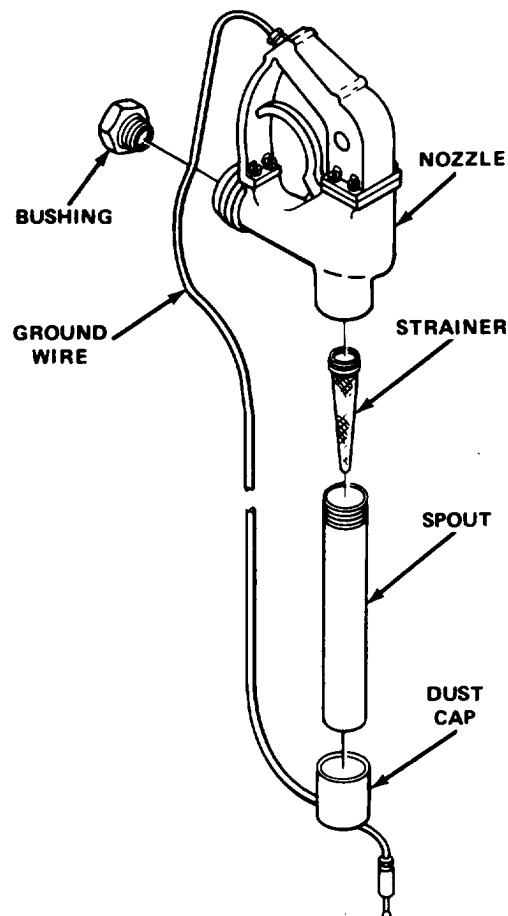

TA223050

*Figure 8-28. Vehicle Nozzle (M969 and M969A1).*

**8-23. Overwing Nozzle (M970 and M970A1)**

- a. *Removal.* Remove overwing nozzle (para 3-15).
- b. *Disassembly (Fig. 8-29).*
- (1) Place nozzle assembly on a clean work area.
  - (2) Unscrew ground wire from nozzle handle.
  - (3) Disconnect the chain for the cap from the nozzle.
  - (4) Unscrew the spout from nozzle handle and remove the strainer.
  - (5) Loosen thumb screw and slide protector ring off end of spout.

c. *Cleaning and Inspection.*

**WARNING**

Dry cleaning solvent P-D-680 is toxic and flammable. Always wear protective goggles and gloves, and use only in a well-ventilated area. Avoid contact with skin, eyes, and clothes, and DO NOT breathe vapors. DO NOT use near open flame or excessive heat. The solvent's flash point is 100°F-138°F (38°C-59°C). If you become dizzy while using cleaning solvent, immediately get fresh air and medical help. If solvent contacts eyes, immediately wash your eyes with water and get medical aid.

(1) Clean the strainer, spout, and nozzle handle with dry cleaning solvent (item 11, Appendix E) and dry thoroughly.

(2) Check spout, screen, protector ring, rubber cap and chain, and ground wire and connector for damage.

(3) Replace any damaged part.

d. *Assembly (Fig. 8-29).*

(1) Attach the protector ring onto the spout.

(2) Insert strainer into spout and screw spout onto handle.

(3) Reconnect cap and chain to the nozzle.

(4) Screw ground wire into nozzle handle.

e. *Installation.* Install overwing nozzle (para 3-15).

**8-24. Underwing Nozzle (M970 and M970A1)**

a. *Removal.* Remove underwing nozzle (para 3-17).

b. *Disassembly (Fig. 8-30).*

(1) Remove adapter (1) from body (2) by grasping knurled portion of adapter and turning counterclockwise.

(2) Remove screen (3) from body (2).

(3) Remove six socket head capscrews (4) and six washers (5) securing body (2) to regulator (6). Remove body (2).

(4) Remove O-ring (33) from body (2).

(5) Remove six socket head capscrews (7) and six washers (8) securing regulator (6) to nozzle body (9). Remove regulator (6).

(6) Remove O-ring from regulator (6).

(7) Remove two capscrews (10), four washers (11), and two lock nuts (12) securing two handles (13) to nozzle collar (29). Remove handles (13).

(8) Remove cover assembly (14) by disconnecting cable latch at the nozzle body.

(9) Remove socket head capscrew (15) and lockwasher (32) securing crank handle (16) to crank (17). Remove crank handle (16).

(10) Remove fiber washer (18) from crank (17).

(11) Remove safety wire (19) attached between bushing (20) and nozzle body (9).

(12) Loosen bushing (20) and slide off crank.

(13) Remove spacer (21) from inside bushing (20).

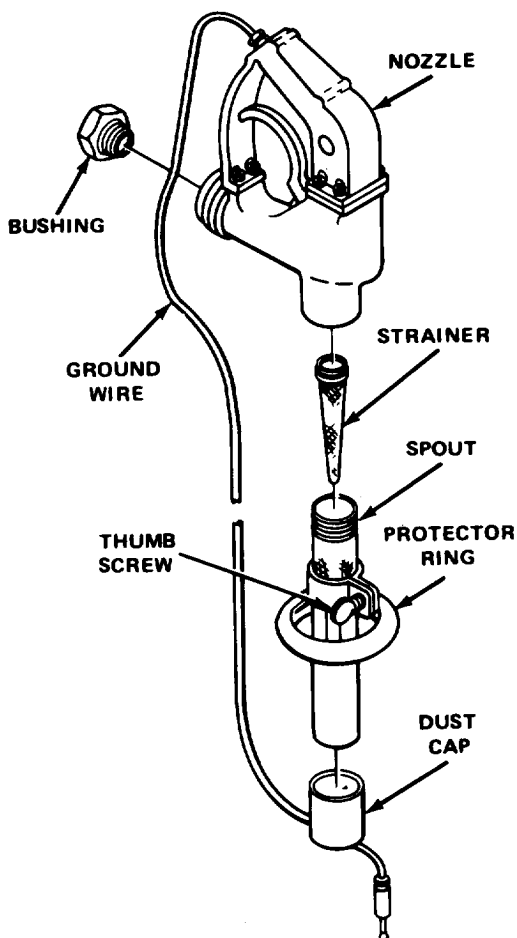

TA221939

Figure 8-29. Overwing Nozzle (M970 and M970A1).

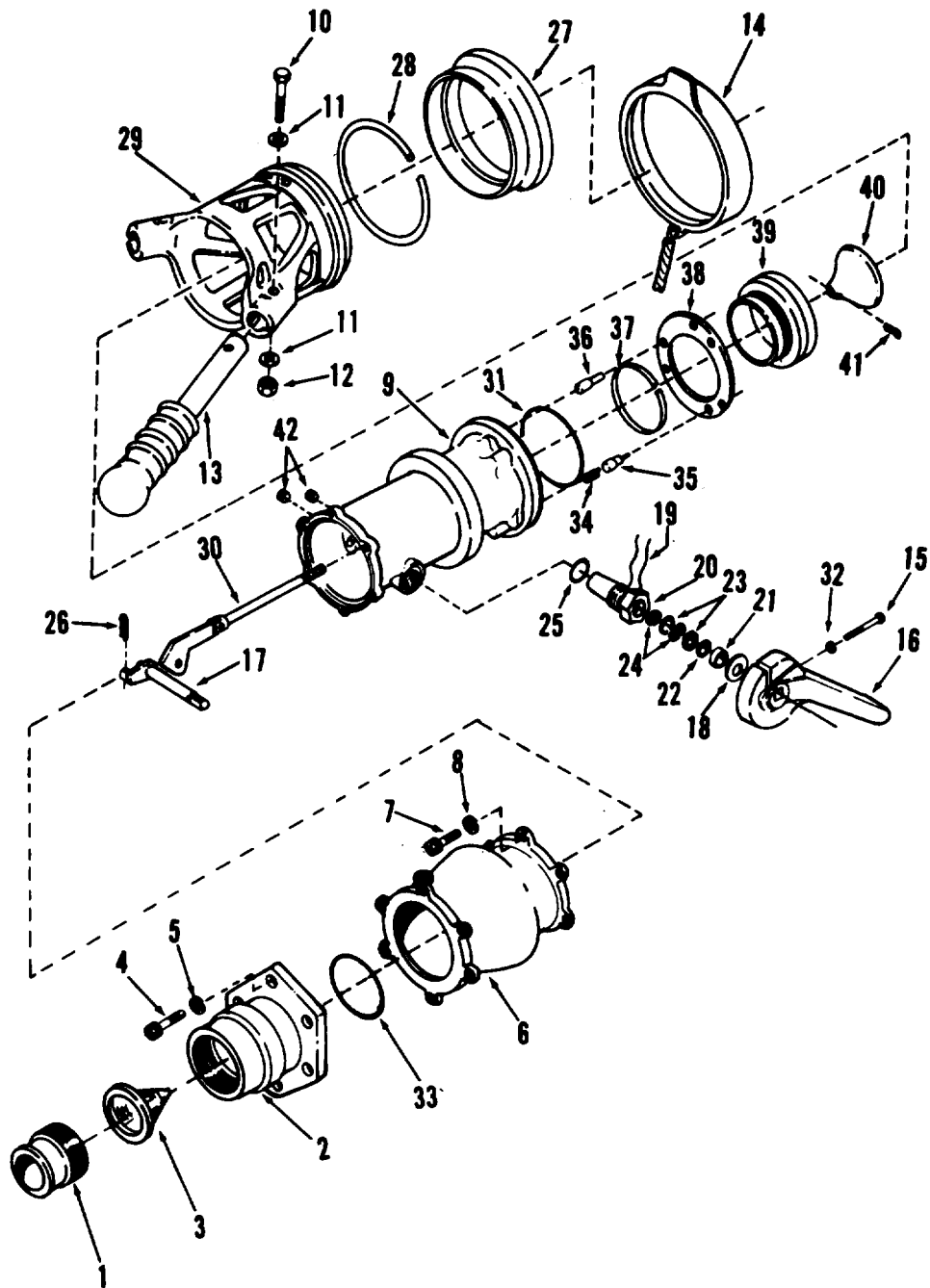

- |                             |                          |                    |
|-----------------------------|--------------------------|--------------------|
| 1. Adapter                  | 15. Socket head capscrew | 29. Collar         |
| 2. Body                     | 16. Crank handle         | 30. Shaft assembly |
| 3. Screen                   | 17. Crank                | 31. Packing        |
| 4. Socket head capscrew (6) | 18. Fiber washer         | 32. Washer         |
| 5. Washer (6)               | 19. Safety wire          | 33. O-ring         |
| 6. Regulator                | 20. Bushing              | 34. Spring (3)     |
| 7. Socket head capscrew (6) | 21. Spacer               | 35. Pin, lock (3)  |
| 8. Washer (6)               | 22. O-ring               | 36. Pin, index (3) |
| 9. Nozzle body              | 23. Flatwasher (2)       | 37. Ring, snap     |
| 10. Capscrew (2)            | 24. Wave washer (2)      | 38. Plate          |
| 11. Washer (4)              | 25. O-ring gasket        | 39. Nose seal      |
| 12. Lock nut (2)            | 26. Hairpin              | 40. Poppet valve   |
| 13. Handle (2)              | 27. Bumper               | 41. O-ring         |
| 14. Cover assembly          | 28. Bearing              | 42. Plug (2)       |

Figure 8-30. Underwing Nozzle (M970 and M970A1).

TA113231

(14) Remove O-ring (22) from inside bushing (20), taking care not to disturb the two flatwashers (23) and two wave washers (24) located directly behind O-ring.

(15) Remove external O-ring gasket (25) from beneath the head of the bushing.

(16) Remove hairpin (26) from end of crank (17) and remove crank.

(17) Remove bumper (27) by prying off nozzle assembly with screwdrivers. It may be necessary to apply heat to the bumper using heat lamps for a period sufficient to soften the bumper. This usually takes from one to two hours.

(18) Remove bearing (28) by applying force to one end of bearing, visible through opening of collar (29), with a straight punch until opposite end of bearing protrudes through collar. Grasp this end with pliers and remove bearing.

(19) Remove collar (29).

(20) Push shaft assembly (30) to move valve as far out of nozzle body as possible.

(21) Remove packing (31) from inside nozzle now visible with valve fully open.

*c. Assembly (Fig. 8-30).*

(1) With valve in the full open position, install packing (31) into nozzle body (9).

(2) Install collar (29) onto nozzle, aligning the groove in the collar with the boss on the nozzle body.

(3) Install bearing (28) by pushing bearing through opening in collar into groove in nozzle body.

(4) Install bumper (27). It may be necessary to heat bumper with heat lamps before installation.

(5) Insert crank (17) through shaft assembly (30), positioning shaft at 12:00 o'clock when crank is at 3:00 o'clock.

(6) Install hairpin (26) into crank (17).

(7) Install O-ring gasket (25) over bushing (20).

(8) Install bushing (20) into nozzle body (9).

(9) Install safety wire (19) between bushing and nozzle body.

(10) Insert O-ring (22) into bushing, over washers (23).

(11) Insert spacer (21) into bushing, over O-ring (22).

(12) Install fiber washer (18) over crank (17). Turn crank counterclockwise with a wrench to fully close the valve.

(13) Install crank handle (16) over crank. Aline groove in crank with screw hole in crank handle. Install socket head capscrew (15) and lockwasher (32).

(14) Install cover assembly (14) by securing cable latch to nozzle body.

(15) Install two handles (13) to collar with two capscrews (10), four washers (11), and two lock nuts (12).

(16) Install O-ring to regulator (6) outlet, indicated with arrow pointing in the direction of flow.

(17) Install regulator (6) to nozzle body(9) with six socket head capscrews (7) and six washers (8), observing direction of flow.

(18) Install O-ring to adapter body (2).

(19) Install body (2) to regulator(6) with six socket head capscrews (4) and six washers (5)

(20) Insert screen (3) into body (2).

(21) Screw adapter (1) into body (2).

*d. Installation.* Install underwing nozzle (para 3-17).

### **8-25. Closed Circuit Nozzle (M970 and M970A1)**

Refer to TM 5-4930-226-12&P manual for disassembly, inspection, and repair of closed-circuit nozzle.

### **8-26. Hose Coupling, 2½-inch**

*a. Removal.* Remove nozzle and coupling (para 3-17).

*b. Disassembly (Fig. 8-31).*

(1) Set sleeves (1 and 2) in disconnected position.

(2) Remove ring (3).

(3) Remove sleeve assembly (2).

(4) Remove bumper (4) from sleeve assembly (2).

(5) Remove spring (5).

(6) Remove three retainers (6).

(7) Remove lock sleeve (1).

- |                    |                        |
|--------------------|------------------------|
| 1. Lock sleeve     | 9. Ring                |
| 2. Sleeve assembly | 10. Sleeve             |
| 3. Ring            | 11. Packing (2)        |
| 4. Bumper          | 12. Pin (2)            |
| 5. Spring          | 13. Spring (2)         |
| 6. Retainer (3)    | 14. Valve assembly (2) |
| 7. Body            | 15. Bumper             |
| 8. Ball (8)        | 16. Packing            |

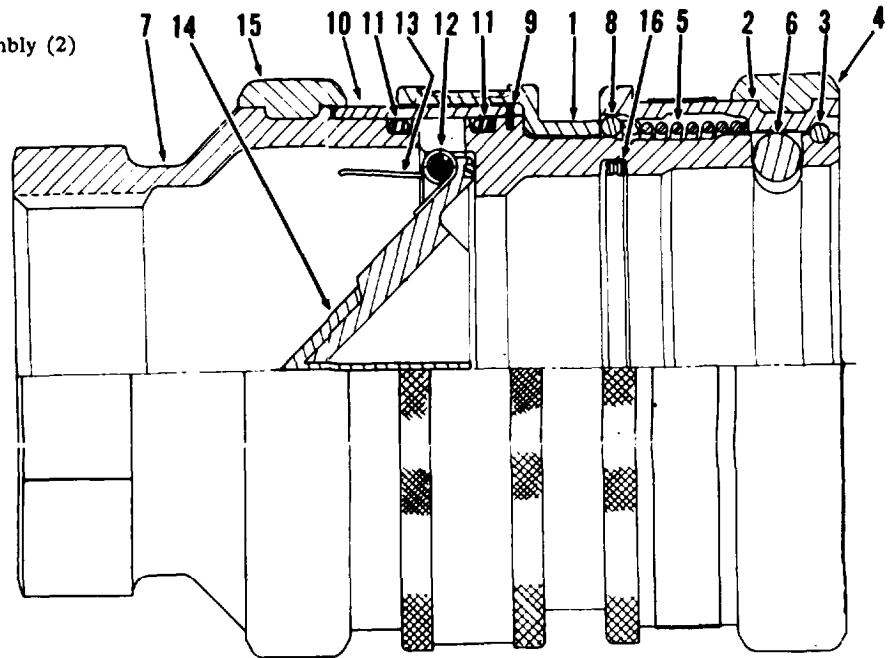

TA157205

**Figure 8-31. 2½-inch Hose Coupling.**

- |   |   |
|---|---|
| <p>(8) Remove eight balls (8) from lock sleeve (1).</p> <p>(9) Remove ring (9) securing sleeve (10) to body (7).</p> <p>(10) Slide sleeve (10) off body (7).</p> <p>(11) Remove two packings (11) from body.</p> <p>(12) Remove two pins (12) securing two springs (13) to two valve assemblies (14).</p> <p>(13) Remove two springs (13) and valve assemblies (14).</p> <p>(14) Remove bumper (15) and packing (16) from body (7).</p> <p>c. <i>Assembly (Fig. 8-31).</i></p> <p>(1) Install packing (16) and bumper (15) on body (7).</p> | <p>(2) Install valve assemblies (14) into body. Using needle nose pliers, move springs (13) into position from outside of valve. Aline holes and install two pins (12).</p> <p>(3) Install two packings (11) to body.</p> <p>(4) Slide sleeve (10) onto body and secure with ring (9).</p> <p>(5) Install eight balls (8) into lock sleeve (10) and then install lock sleeve (10) onto body.</p> <p>(6) Install three retainers (6) into body (7).</p> <p>(7) Install spring (5).</p> <p>(8) Install bumper (4) on sleeve assembly (2) and then install sleeve on body.</p> <p>(9) Install ring (3).</p> <p>d. <i>Installation.</i> Install coupling (para 3-17).</p> |
|---|---|





## APPENDIX A REFERENCES

---

### A-1. Scope

This appendix lists forms, field manuals, technical manuals, and other publications referenced in this manual and which apply to the operation, organizational maintenance, and direct and general support maintenance of the semitrailers.

#### A-1. Department of the Army Pamphlets

Consolidated Index of Army Publications and Blank Forms .....	DA Pam 25-30
Index and Description of Army Training Devices .....	DA Pam 310-12
Using Unit Supply System (Manual Procedures) .....	DA Pam 710-2-1
The Army Maintenance Management System (TAMMS) .....	DA Pam 738-750

#### A-3. Forms

Recommended Changes to Publications and Blank Forms .....	DA Form 2028
Recommended Changes to Equipment Technical Publications .....	DA Form 2028-2
Organizational Control Record for Equipment .....	DA Form 2401
Equipment Inspection and Maintenance Worksheet .....	DA Form 2404
Maintenance Request .....	DA Form 2407
Preventive Maintenance Schedule and Record .....	DD Form 314
Processing and Reprocessing Record for Shipment, Storage, and Issue of Vehicles and Spare Engines .....	DD Form 1397
Report of Discrepancy (ROD) .....	SF 364
Product Quality Deficiency Report .....	SF 368

#### A-4. Field Manuals

NBC Contamination Avoidance .....	FM 3-3
NBC Protection .....	FM 3-4
NBC Decontamination .....	FM 3-5
Field Behavior of NBC Agents (Including Smoke and Incendiaries) .....	FM 3-6
Camouflage .....	FM 5-20
Route Reconnaissance and Classification .....	FM 5-36
Ammunition Handbook .....	FM 9-13
Operation and Maintenance of Ordnance Material in Cold Weather (0° to -65°F) .....	FM 9-207
Organizational Maintenance of Military Petroleum Pipelines, Tanks and Related Equipment .....	FM 10-20
Aircraft Refueling .....	FM 10-68
Petroleum Supply Point Equipment and Operations .....	FM 10-69
Petroleum Tank Vehicle Operations .....	FM 10-71
Vehicle Recovery Operations .....	FM 20-22
First Aid for Soldiers .....	FM 21-11
Manual for the Wheeled Vehicle Driver .....	FM 21-305
Training in Units .....	FM 25-3
Basic Cold Weather Manual .....	FM 31-70
Northern Operations .....	FM 31-71
Army Motor Transport Units and Operators .....	FM 55-30
Desert Operations (How to Fight) .....	FM 90-3
Mountain Operations .....	FM 90-6
Operational Terms and Symbols .....	FM 101-5-1

**A-5. Supply Bulletins**

Storage Serviceability Standard: Tracked Vehicles,  
 Wheeled Vehicles, and Component Parts . . . . . SB 740-98-1

**A-6. Technical Bulletins**

Hand Portable Fire Extinguishers Approved for Army Users . . . . . 5-4200-200-100  
 Tactical Wheeled Vehicles: Repair of Frames . . . . . TB 9-2300-247-40  
 Air Pollution Control Procedures for Military Vehicles: Construction  
 Equipment and Materials Handling Equipment . . . . . TB 9-2300-402-10  
 Equipment Improvement Report and Maintenance Digest (US Army Tank-  
 Automotive Command) Tank and Automotive Equipment . . . . . TB 43-0001-39 Series  
 Maintenance Expenditure Limits for Tactical Wheeled Vehicles . . . . . TB 43-0002-81  
 Purging, Cleaning and Coating Interior Ferrous and Terne Sheet  
 Vehicle Fuel Treks . . . . . TB 43-0212  
 Color, Marking, and Camouflage Painting of Military Vehicles, Construction  
 Equipment, and Materiels Handling Equipment . . . . . TB 43-0209  
 Corrosion Prevention and Control Including Rustproofing Procedures  
 for Tactical Vehicles and Trailers . . . . . TB 43-0213  
 Maintenance in the Desert . . . . . TB 43-0239  
 Description, Use, Bonding Techniques, and Properties of Adhesives . . . . . TB ORD 1032

**A-7. Technical Manuals**

Operator and Organizational Maintenance Manual (Including  
 Repair Parts and Special Tools List) for Nozzle Assembly,  
 Closed-Circuit Refueling w/Strainer Assembly . . . . . TM 5-4930-226-12&P  
 Inspection, Care, and Maintenance of Antifriction Bearings . . . . . TM 9-214  
 Operator's Manual for Welding Theory and Application . . . . . TM 9-237  
 Deepwater Fording of Ordnance Materiel . . . . . TM 9-238  
 Materials Used for Cleaning, Preserving, Abrading, and Cementing  
 Ordnance Materiel and Related Items Including Chemicals . . . . . TM 9-247  
 Unit, Direct Support, and General Support Maintenance Repair  
 Parts and Special Tools Lists for Semitrailer, Tank: 5000 Gallon,  
 M967, M967A1, M969, M969A1, M970, M970A1 . . . . . TM 9-2330-356-24P  
 Organizational, Direct Support, and General Support Care,  
 Maintenance, and Repair of Pneumatic Tires and Inner Tubes . . . . . TM 9-2610-200-24  
 Operator's, Organizational, Direct Support and General Support  
 Maintenance Manual for Lead-Acid Storage Batteries . . . . . TM 9-6140-200-14  
 Painting Instructions for Field Use.. . . . . TM 43-0139  
 Railway Operating and Safety Rules . . . . . TM 55-200  
 Railcar Loading Procedures . . . . . TM 55-601  
 Storage and Materials Handling . . . . . TM 743-200-1  
 Procedures for Destruction of Trek-Automotive Equipment to Prevent Enemy Use . . . . . TM 750-244-6  
 Direct Support and General Support Quality Control for Inspector's  
 Inspection Criteria . . . . . TM 750-245-4

**A-8. Other Publications**

Army Medical Department Expendable/Durable Items . . . . . CTA 8-100  
 Expendable/Durable Items (Except Medical, Classy Repair Parts, and Heraldic Items) . . . . . CTA 50-970

## APPENDIX B MAINTENANCE ALLOCATION CHART

---

### Section I. INTRODUCTION

#### B-1. General

a. This section provides a general explanation of all maintenance and repair functions authorized at the various maintenance levels.

b. The Maintenance Allocation Chart (MAC) in Section II designates overall authority and responsibility for the performance of maintenance functions on the identified end item or component. The application of the maintenance functions to the end item or component will be consistent with the capacities and capabilities of the designated maintenance levels.

c. Section III lists the tools and test equipment (both special tools and common tool sets) required for each maintenance function as referenced from Section II.

d. Section IV contains supplemental instructions and explanatory notes for a particular maintenance function.

#### B-2. Maintenance Functions

Maintenance functions will be limited to and defined as follows:

*a. Inspect.* To determine the serviceability of an item by comparing its physical, mechanical, and/or electrical characteristics with established standards through examination (e.g., by sight, sound, or feel).

*b. Test.* To verify serviceability by measuring the mechanical, pneumatic, hydraulic, or electrical characteristics of an item and comparing those characteristics with prescribed standards.

*c. Service.* Operations required periodically to keep an item in proper operating condition, i.e., to clean (includes decontaminate, when required), to preserve, to drain, to paint, or to replenish fuel, lubricants, chemical fluids, or gases.

*d. Adjust.* To maintain or regulate, within prescribed limits, by bringing into proper or exact position, or by setting the operating characteristics to specified parameters.

*e. Align.* To adjust specified variable elements of an item to bring about optimum or desired performance.

*f. Calibrate.* To determine and cause corrections to be made or to be adjusted on instruments or test,

measuring, and diagnostic equipments used in precision measurement. Consists of comparisons of two instruments, one of which is a certified standard of known accuracy, to detect and adjust any discrepancy in the accuracy of the instrument being compared.

*g. Remove/Install.* To remove and install the same item when required to perform service or other maintenance functions. Install may be the act of emplacing, seating, or fixing into position a spare, repair part, or module (component or assembly) in a manner to allow the proper functioning of an equipment or system.

*h. Replace.* To remove an unserviceable item and install a serviceable counterpart in its place. "Replace" is authorized by the MAC and is shown as the third position of the SMR code.

*i. Repair.* The application of maintenance services, including fault location/troubleshooting, removal/ installation, and disassembly/assembly procedures, and maintenance actions to identify troubles and restore serviceability to an item by correcting specific damage, fault, malfunction, or failure in a part, subassembly, module (component or assembly), end item, or system.

*j. Overhaul.* That maintenance effort (service/action) prescribed to restore an item to a completely serviceable/operational condition as required by maintenance standards in appropriate technical publications (i.e., DMWR). Overhaul is normally the highest degree of maintenance performed by the Army. Overhaul does not normally return an item to like new condition.

*k. Rebuild.* Consists of those services/actions necessary for the restoration of unserviceable equipment to a like new condition in accordance with original manufacturing standards. Rebuild is the highest degree of materiel maintenance applied to Army equipment. The rebuild operation includes the act of returning to zero those age measurements (hours/miles, etc.) considered in classifying Army equipment/components.

#### B-3. Explanation of Columns In the MAC, Section II

*a. Column 1, Group Number.* Column 1 lists functional group code numbers, the purpose of which is to identify maintenance significant components, assemblies, subassemblies, and modules with the next higher assembly. End item group number shall be "00."

*b. Column 2, Component/Assembly.* Column 2 contains the names of components, assemblies, subassemblies, and modules for which maintenance is authorized.

**B-3. Explanation of Columns in the MAC, Section II (Con't)**

c. *Column 3, Maintenance Function.* Column 3 lists the functions to be performed on the item listed in Column 2. (For a detailed explanation of these functions, see paragraph B-2.)

d. *Column 4, Maintenance Level.* Column 4 specifies, by the listing of a work time figure in the appropriate sub-column(s), the level of maintenance authorized to perform the function listed in Column 3. This figure represents the active time required to perform that maintenance function at the indicated level of maintenance. If the number or complexity of the tasks within the listed maintenance function vary at different maintenance levels, appropriate work time figures will be shown for each level. The work time figure represents the average time required to restore an item (assembly, subassembly, component, module, end item, or system) to a serviceable condition under typical field operating conditions. This time includes preparation time (including any necessary disassembly/assembly time), troubleshooting/fault location time, and quality assurance/quality control time in addition to the time required to perform the specific tasks identified for the maintenance functions authorized in the Maintenance Allocation Chart. The symbol designations for the various maintenance levels are as follows:

- C . . . . Operator or Crew
- O . . . . Unit Maintenance
- F . . . . Direct Support Maintenance
- H . . . . General Support Maintenance
- D . . . . Depot Maintenance

e. *Column 5, Tools and Equipment.* Column 5 specifies, by code, those common tool sets (not individual

tools) and special tools, TMDE, and support equipment required to perform the designated function.

f. *Column 6, Remarks.* This column shall, when applicable, contain a letter code, in alphabetic order, which shall be keyed to the remarks contained in Section IV.

**B-4. Explanation of Columns in Tool and Test Equipment Requirements, Section III**

a. *Column 1, Tool or Test Equipment Reference Code.* The tool and test equipment reference code correlates with a code used in the MAC, Section II, Column 5.

b. *Column 2, Maintenance Level.* The lowest level of maintenance authorized to use the tool or test equipment.

c. *Column 3, Nomenclature.* Name or identification of the tool or test equipment.

d. *Column 4, National/NATO Stock Number.* The National or NATO Stock Number of the tool or test equipment.

e. *Column 5, Tool Number.* The manufacturer's part number.

**B-5. Explanation of Columns in Remarks, Section IV**

a. *Column 1, Reference Code.* The code recorded in Column 6, Section II.

b. *Column 2, Remarks.* This column lists information pertinent to the maintenance function being performed as indicated in the MAC, Section II.

**Section II. MAINTENANCE ALLOCATION CHART**

(1) Group Number	(2) Component/Assembly	(3) Maintenance Function	(4) Maintenance Level				(5) Tools and Equipment	(6) Remarks	
			Unit		DS	GS			Depot
			C	O	F	H			D
<b>06</b>	<b>ELECTRICAL SYSTEM</b>								
0607	Instrument or Engine Control Panel								
	Wiring, Switches, Decals, Connectors, Conduits, Etc.	Test Replace Repair	0.6 0.5 1.0						
	Tachometer, Voltmeter, Hourmeter	Test Replace	0.6 1.0						

Section II. MAINTENANCE ALLOCATION CHART - Continued

(1) Group Number	(2) Component/Assembly	(3) Maintenance Function	(4) Maintenance Level					(5) Tools and Equipment	(6) Remarks
			Unit		DS	GS	Depot		
			C	O	F	H	D		
0608	Miscellaneous Items								
	Box, Triple Marker Rear: Wiring, Connectors, Etc.	Test Repair		0.6 1.0					
0609	Lights								
	Marker, Composite, Tail, Stop	Test Replace Repair		0.6 1.0 1.0					
0610	Sending Units and Warning Switches	Test Replace		0.6 1.0					
0612	Batteries, Storage								
	Battery, Cover, Box, Terminals, Cables	Service Test Replace Repair	0.3	0.5 1.0 1.0					
0613	Chassis Wiring Harness								
	Chassis Wiring, Connectors, Vehicle Coupling	Test Replace Repair		0.6 3.0 3.0					
11	<b>REAR AXLE</b>								
1100	Rear Axle Assembly								
	Complete Rear Bogie Attaching Parts: Mounting, Gaskets, Seals, and Bearings. Tandem Tubes and Spring Seats	Service Replace Repair		4.0	6.0 4.0				
12	<b>BRAKES</b>								
1202	Service Brakes								
	Service Brake Shoe Assemblies and Adjusting Parts	Test Adjust Replace Repair		1.5 1.0 4.0	8.0				

Section II. MAINTENANCE ALLOCATION CHART - Continued

(1) Group Number	(2) Component/Assembly	(3) Maintenance Function	(4) Maintenance Level				(5) Tools and Equipment	(6) Remarks	
			Unit		DS	GS			Depot
			C	O	F	H			D
1208	<i>Air Brake System</i>								
	Coupling, Air Lines and Fittings, Dummy Couplings	Test Replace Repair		0.6 0.5 0.5					
	Chamber, Air, Standard	Test Replace Repair		0.2 2.0	2.0				
	Chamber, Air, Fail Safe	Test Replace		0.2 2.0					
	Valve Emergency Relay	Test Replace		0.6 2.0					
	Reservoir, Air and Drain Cock	Service Replace	0.2	1.0					
13	<b>WHEELS</b>						1,2,3,4,8	A,B	
1311	<i>Wheel Assembly</i>								
	Wheel Assembly, Nuts, Studs, Rings	Replace		0.3					
	Hub and Drum	Replace Repair		1.0	1.0				
	Bearings	Service Replace		0.5 1.0					
	Seals and Wipers	Service Replace		0.5 1.0					
1313	<i>Tires, Tubes</i>								
	Tubes	Service Replace Repair		1.0 0.5 1.0					
	Tires	Replace Repair		0.5		1.0			
15	<b>FRAME, TOWING ATTACHMENTS</b>						1,2,3,4,5	A,B	
1501	<i>Frame Assembly</i>								
	Frame Bumpers, Brackets	Repair			2.0				

Section II. MAINTENANCE ALLOCATION CHART - Continued

(1) Group Number	(2) Component/Assembly	(3) Maintenance Function	(4) Maintenance Level					(5) Tools and Equipment	(6) Remarks
			Unit		DS	GS	Depot		
			C	O	F	H	D		
1501	<i>Frame Assembly (Con't)</i>								
	Control, Emergency Valve, Cables	Service Adjust Replace		0.5 1.0 2.0					
1503	<i>Pintles and Towing Attachments</i>								
	Bolt-on Kingpin	Service Replace		0.3 0.5					
	Upper Coupler (Kingpin) Plate	Service Replace		0.3	2.0				
1504	<i>Spare Wheel Carrier and Tire Lock</i>								
	Carrier, Spare Wheel	Service Replace		0.3	1.0				
1507	<i>Landing Gear, Leveling Jacks</i>								
	Landing Gear, Crank, Jack, Pad and Brackets	Service Replace Repair		0.2 2.0	6.0				
	Board Assembly, Landing Gear	Replace		0.5					
<b>16</b>	<b>SPRINGS</b>						1,2,3	A,B	
1601	<i>Springs</i>								
	Springs and Attaching Parts	Replace			4.0				
1605	<i>Torque, Radius, and Stabilizer Rods</i>	Replace Repair			2.0 2.0				
<b>18</b>	<b>BODY</b>						1,2,3,4	A,B	
1801	<i>Body</i>								
	Brackets, Splash Plates, Mudflaps	Replace Repair		0.6	2.0				

Section II. MAINTENANCE ALLOCATION CHART - Continued

(1) Group Number	(2) Component/Assembly	(3) Maintenance Function	(4) Maintenance Level					(5) Tools and Equipment	(6) Remarks
			Unit		DS	GS	Depot		
			C	O	F	H	D		
1808	<i>Stowage Racks, Boxes, Straps, Carrying Cases, Cable Reels, Hose Reels, Etc.</i>								
	Stowage Racks	Service Repair	0.2		1.0				
	Cabinets	Service Repair Replace	0.2		1.0 8.0				
	Hose Reels	Service Replace Repair	0.2		1.5 8.0				
	Tool Box	Service Replace Repair	0.1		0.5 0.3				
	Cabinet Doors	Service Replace Repair	0.2		0.6 1.0				
	1811	<i>Tank Bodies</i>							
Cover Manhole		Service Replace		0.2 0.5					
Clamp, Gasket Manhole Cover		Replace		0.5					
Drain, Ladder		Service		0.2					
Tank		Service Repair			0.6 8.0				
22	<b>BODY ACCESSORY ITEMS</b>						1,2,3	A,B	
2202	<i>Accessory Items</i>								
	Accessories, Transfer Hoses, Caps, Fuel Servicing, Reflectors, Plugs	Replace Repair		1.0 2.0					



Section II. MAINTENANCE ALLOCATION CHART - Continued

(1) Group Number	(2) Component/Assembly	(3) Maintenance Function	(4) Maintenance Level					(5) Tools and Equipment	(6) Remarks
			Unit		DS	GS	Depot		
			C	O	F	H	D		
2210	<i>Data Plates and Instruction Holders</i>	Replace		1.0				1.2,3,4, 5,6,7,9	A,B
29	<b>ENGINE ASSEMBLY</b>								
2910	<i>Engine Assembly</i>	Test Service Replace Repair		1.8	2.0				
	Engine				4.0	6.0			
2911	<i>Crankcase, Cylinder Sleeve, Cylinder Head and Block</i>		Test Service Replace Repair		2.0	2.0			
	Crankcase, Cylinder Head and Block				4.0	6.5			
2912	<i>Crankshaft</i>	Replace				8.0			
2913	<i>Flywheel Assembly</i>	Replace			3.0				
	Flywheel and Ring Gear								
2914	<i>Pistons and Connecting Rods</i>	Replace				5.0			
2915	<i>Valves, Camshaft, and Timing System</i>	Adjust Replace Repair			2.0	4.0 4.0			
2916	<i>Engine Lubrication System</i>	Test Repair Replace			0.5				
	Engine Lubrication System, Oil Filter			0.2		2.0			
2932	<i>Engine Fuel Pump</i>	Test Service Replace Repair			1.5				
	Engine Fuel Injection Pump, and Electric Fuel Pumps			0.5		2.0			
						2.0			

Section II. MAINTENANCE ALLOCATION CHART - Continued

(1) Group Number	(2) Component/Assembly	(3) Maintenance Function	(4) Maintenance Level					(5) Tools and Equipment	(6) Remarks
			Unit		DS	GS	Depot		
			C	O	F	H	D		
2933	Engine Air Cleaner	Service Replace	0.5	0.5					
2935	Engine Fuel Tank								
	Engine Fuel Tank, Lines	Test		1.0					
		Service Replace		0.5					
		Replace		1.0					
2937	Engine Fuel Filter								
	Engine Fuel Filter, Primary and Secondary	Service Replace		0.5					
		Replace		0.5					
2939	Engine Throttle and Choke Controls	Adjust		1.0					
		Service Replace		1.0	3.0				
2941	Engine Muffler Exhaust and Tall Pipes								
	Engine Muffler Exhaust	Replace		1.0					
2952	Engine Cowling Deflectors, Air Ducts, and Shrouds								
	Engine Cowling and Shroud	Replace Repair		1.0	1.0				
2961	Generator								
	Engine Alternator	Adjust			0.5				
		Replace		1.0					
		Repair			1.5				
	Drive Belt (M967A1 M969A1, M970A1),	Replace		1.0					
	Drive Belt (M967, M969 M970)	Replace			1.0				
2963	Starter, Solenoids, Circuit Breakers, Wiring, and Switches								
	Starter, Solenoids, Wiring, Switches, Control Panel	Test		0.5					
		Service Replace		0.1					
		Replace		1.0					
		Repair			1.0				

Section II. MAINTENANCE ALLOCATION CHART - Continued

(1) Group Number	(2) Component/Assembly	(3) Maintenance Function	(4) Maintenance Level					(5) Tools and Equipment	(6) Remarks
			Unit		DS	GS	Depot		
			C	O	F	H	D		
<b>33</b>	<b>SPECIAL PURPOSE KITS</b>								
3307	<i>Special Purpose Kits</i>								
	Vapor Recovery Piping	Service Replace Repair		1.0 8.0 4.0					
<b>47</b>	<b>GAGES (NONELECTRICAL), WEIGHING AND MEASURING DEVICES</b>								
4702	<i>Gages, Mountings, Lines, and Fittings</i>								
	Oil, Fuel, Pump	Test Replace		0.1 0.3					
<b>56</b>	<b>FILTERS, SEPARATORS</b>						1,2,3,4,5	A,B	
5600	<i>Fuel, Water, Air, Filter/ Separation or Purifier Assembly</i>								
	Filter/Separator Assembly Elements and Go-No-Go Fuses	Service Replace Repair		1.0 1.0 1.0					
	Filter/Separator Tank	Replace			3.0				
5601	<i>Automatic Discharge and Relief Valve</i>								
	Sump Components, Valve and Float	Service Replace Repair	0.5	2.0	2.0				
<b>72</b>	<b>DISPENSING AND SERVICING EQUIPMENT COMPONENTS</b>						1,2,3,4,5	A,B	
7202	<i>Pumps and Meters</i>								
	Pump, Centrifugal	Service Replace Repair		1.0	3.0 4.0				

Section II. MAINTENANCE ALLOCATION CHART - Continued

(1) Group Number	(2) Component/Assembly	(3) Maintenance Function	(4) Maintenance Level					(5) Tools and Equipment	(6) Remarks
			Unit		DS	GS	Depot		
			C	O	F	H	D		
7202	<i>Pumps and Meters (Con't)</i>								
	Meter	Replace			3.0				
7203	<i>Valves, Fittings, Lines</i>								
	Valves, Fittings, Lines, Piping and Controls, Including Deadman	Service Replace Repair		1.5 3.0	3.0				
7204	<i>Miscellaneous Parts and Accessories</i>								
	Nozzles	Test Service Replace Repair		1.0 1.0	0.5 4.0				

**Section III. TOOL AND TEST EQUIPMENT REQUIREMENTS**

(1) Tool or lost Equipment Reference Code	(2) Maintenance Level	(3) Nomenclature	(4) National/NATO Stock Number	(5) Tool Number
1	O	Tool Kit, General, Mechanic's Automotive	5180-00-177-7033	
2	O	Shop Equipment, Automotive Maintenance and Repair, Organizational Maintenance, Common No. 1	4910-00-754-0654	
3	O	Shop Equipment, Automotive Maintenance and Repair, Organizational Maintenance, Common No. 1, Less Power	4910-00-754-0653	
4	F	Shop Equipment, Automotive Maintenance and Repair Field Maintenance	4910-00-754-0705	
5	H	Shop Equipment, Wheeled Field Maintenance Post, Camp and Station	4910-00-348-7696	
		SPECIAL TOOLS:		
6	F	Driver, Bearing, Front and Rear Camshaft and Main Drive	5120-00-125-4402	420-0326
7	F	Driver, Oil Seal Rear Crankshaft	5120-00-125-4411	420-0250
8	F	Gage, Compression Test	4910-00-870-6283	10699180

**Section IV. REMARKS**

(1) Reference Code	(2) Remarks
A	Direct Support (F) maintenance includes replacement of repairable assemblies, repair of components or assemblies considered uneconomical to evacuate further. Performs adjustments of systems for which organizational maintenance does not possess skills or test equipment.
B	General Support (H) maintenance includes repair of most replaceable assemblies. Overhaul of assemblies which require extensive work in terms of man-hours, skills, and testing of overhauled assemblies will be accomplished at depots.



**APPENDIX C  
COMPONENTS OF END ITEM AND BASIC ISSUE ITEMS LISTS**

---

**Section I. INTRODUCTION**

**C-1. Scope**

This appendix lists components of the end item and basic issue items for the semitrailers to help you inventory items required for safe and efficient operation.

**C-2. General**

These components of End Item and Basic Issue Items Lists are divided into the following sections:

*a. Section II. Integral Components of End Item.* This listing is for informational purposes only, and is not authority to requisition replacements. These items are part of the end item, but are removed and separately packaged for transportation or shipment. As part of the end item, these items must be with the end item whenever it is issued or transferred between accounts. Illustrations are furnished to assist you in identifying the items.

*b. Section III. Basic Issue Items.* These are the minimum essential items required to place the semitrailer in operation, to operate it, and to perform emergency repairs. Although shipped separately, packaged BII must be with the semitrailer during operation and whenever it is transferred between property accounts. The illustrations will assist you with hard-to-identify items. This manual is your authority to request/requisition replacement BII, based on TOE/MTOE authorization of the end item.

**C-3. Explanation of Columns**

The following provides an explanation of columns found in the tabular listings.

*a. Column (1) –Illustration Number (Illus Number).* This column indicates the number of the illustration in which the item is shown.

*b. Column (2) –National Stock Number.* Indicates the National stock number assigned to the item and will be used for requisitioning purposes.

*c. Column (3) –Description.* Indicates the National item name and, if required, a minimum description to identify and locate the item. The last line for each item indicates the FSCM (in parenthesis) followed by the part number. If item needed differs for different models of this equipment, the model is shown under the “Usable On Code” heading in this column. These codes are identified as:

<b>Code</b>	<b>Used On</b>
C70, C90	Model M967, M967A1
C72, C92	Model M969, M969A1
C73, C91	Model M970, M970A1

*d. Column (4) – Unit of Measure (U/M).* Indicates the measure used in performing the actual operational/maintenance function. This measure is expressed by a two-character alphabetical abbreviation (e.g., ea, in, pr).

*e. Column (5)–Quantity required (Qty. rqr).* Indicates the quantity of the item authorized to be used with/on the equipment.

Section II. COMPONENTS OF END ITEM

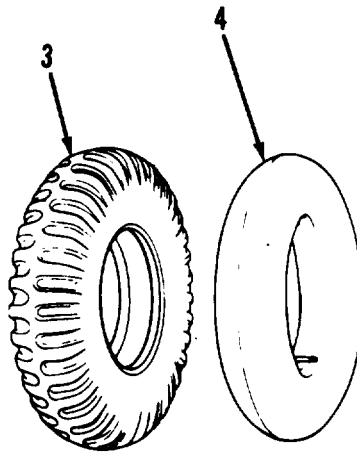
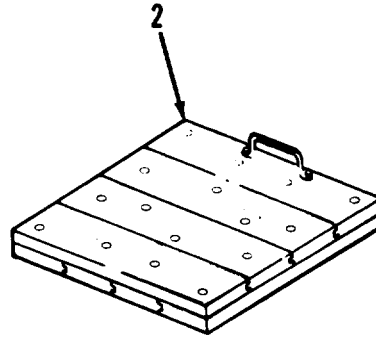
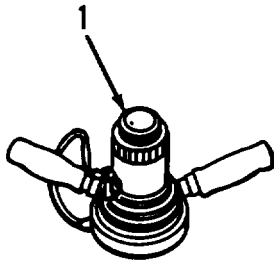

TA502374

(1) Illus Number	(2) National Stock Number	(3) Description FSCM and Part Number	Usable on Code	(4) U/M	(5) Qty Rqr
1	1560-00-949-2087	ADAPTER, D-1 (96906) MS24484-2	C73, C91	EA	1
2	2510-00-741-7585	BOARD, GROUND (at landing legs) (19207) 7417585		EA	2
3	2610-00-262-8653	TIRE, SPARE (rear bracket) (81349) MIL-T-12459		EA	1
4	2610-00-051-9450	TUBE, INNER, PNEUMATIC (rear bracket) (81348) ZZ-1-550/G2/11.0		EA	1



Section III. BASIC ISSUE ITEMS

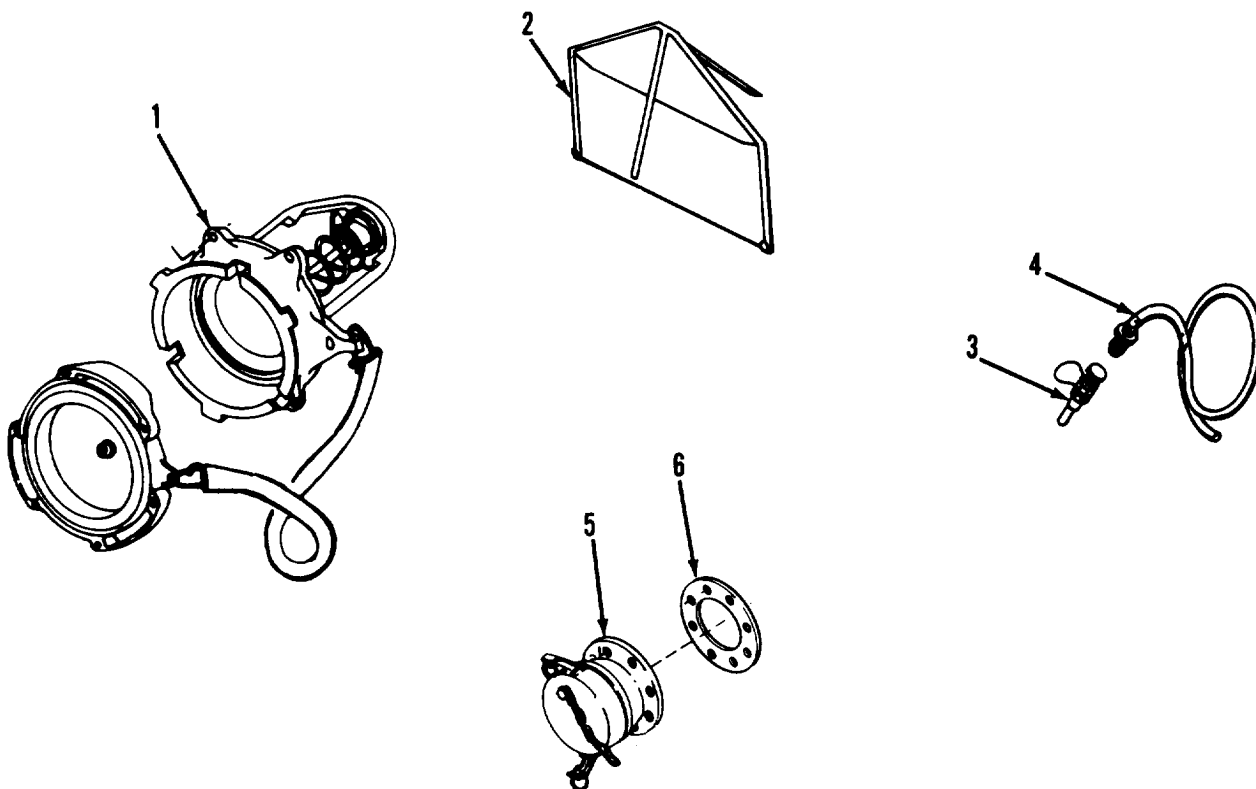

TA502375

(1) Illus Number	(2) National Stock Number	(3) Description FSCM and Part Number	Usable on Code	(4) U/M	(5) Qty Rqr
1	4930-00-333-6573	ADAPTER, OVERWING (tool box) (19207) 11668856-1	C73, C91	EA	1
2	5140-00-772-4142	BAG, TOOL (tool box) (19207) 7724142	C70, C72 C90, C91, C92, C73	EA EA EA	1 2 3
2	8105-01-283-5710	BAG, TOOL (tool box) (19207) 12275300	C73, C91	EA	2
3	4730-01-065-9388	COUPLING, FUEL SAMPLING (tool box) (19207) 11668856	C72, C92, C73, C91	EA	1
4	4720-01-064-8820	COUPLING, FUEL SAMPLING (tool box) (19207) 11668857	C72, C92, C73, C91	EA	1
5	4730-01468-8675	COUPLING, HALF, QUICK DISCONNECT (tool box) (19207) 11668074		EA	1
6	5330-01-061-5070	GASKET (use with coupling 11668074) (19207) 11668581		EA	1

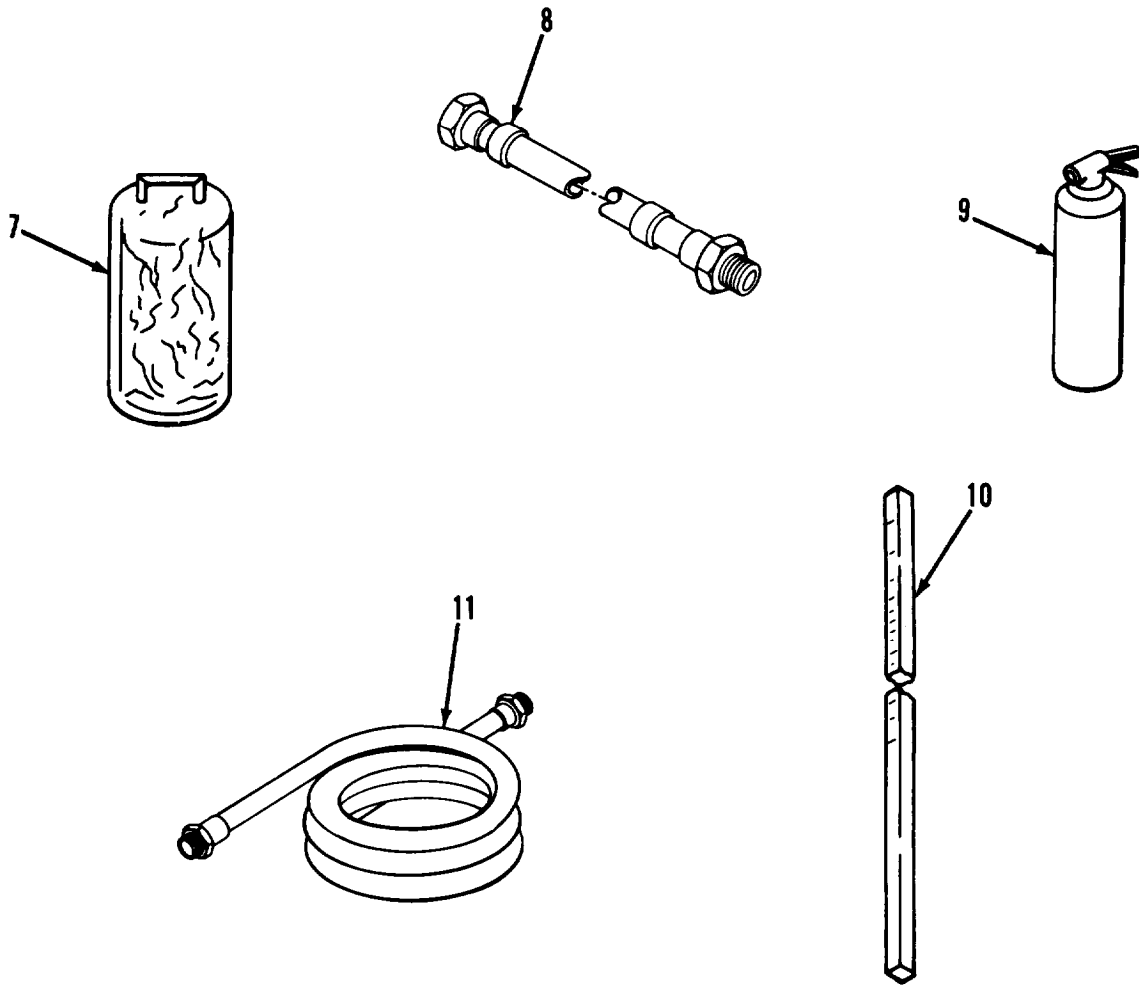

TA502376

(1) Illus Number	(2) National Stock Number	(3) Description FSCM and Part Number	Usable on Code	(4) U/M	(5) Qty Rqr
7	2540-01-080-5597	COVER, FIRE EXTINGUISHER (on extinguishers) (19207) 11668081		EA	2
8	4720-01-072-8355	DUPLEX HOSE, RUBBER (19207) 11668581	C73, C91	EA	2
9	4210-00-808-4544	EXTINGUISHER, FIRE (rear and side bracket) (03670) IK10E		EA	2
10	5210-01-054-9934	GAGE, STICK (stowage tube) (19207) 11885988		EA	1
11	472000-481-3798	HOSE ASSEMBLY 1-1/2 in X 50 ft (19207) 11597599	C73, C91,	EA	1
11	4720-00-461-3797	HOSE ASSEMBLY 2-1/2 in X 50 ft (19207) 11597598	C73, C91	EA	1
11	4720-01-058-6032	HOSE ASSEMBLY 1-1/4 in X 50 ft (19207) 11685953	C72, C92	EA	2

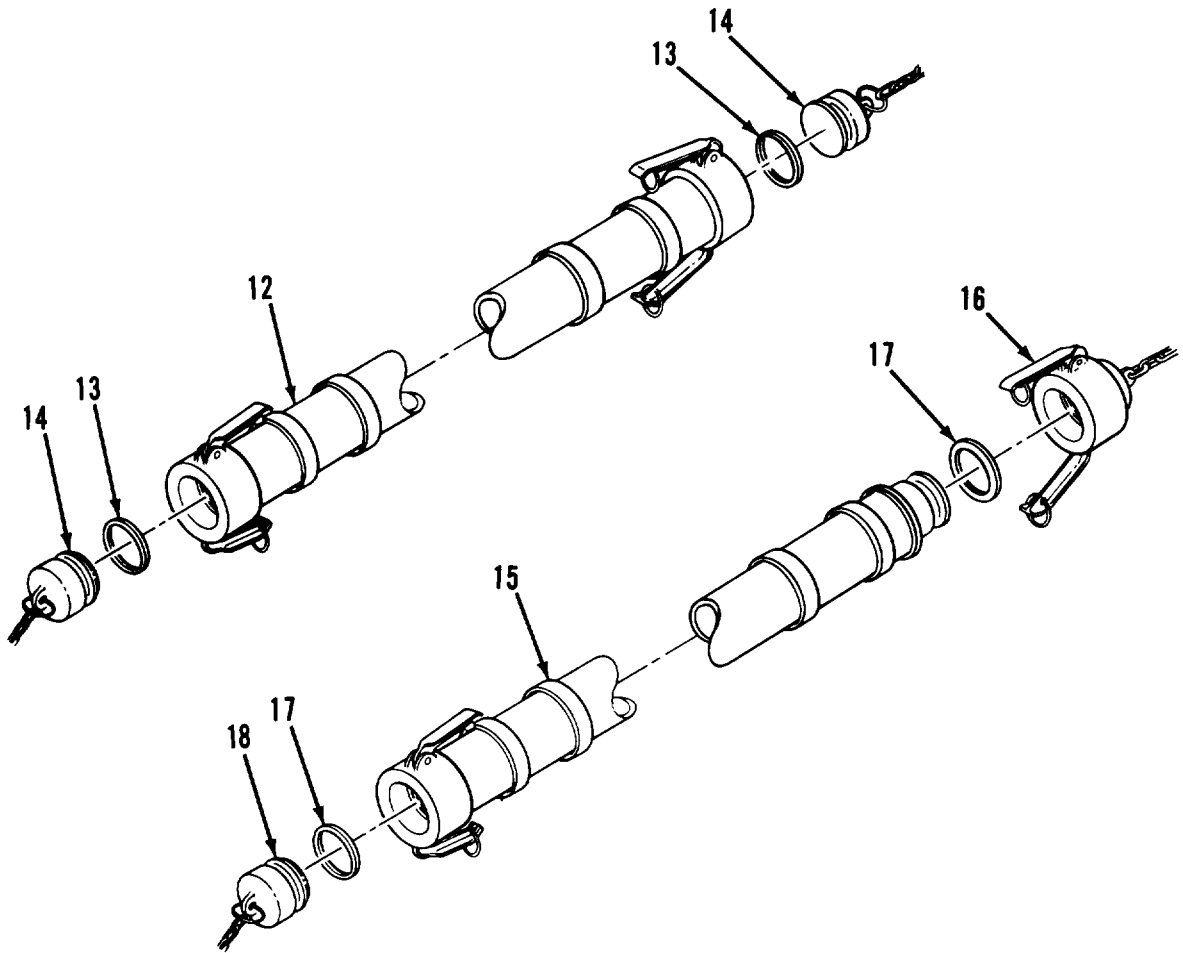

TA502377

(1) Illus Number	(2) National Stock Number	(3) Description FSCM and Part Number	Usable on Code	(4) U/M	(5) Qty Rqr
12	4720-01-096-4390	HOSE, TRANSFER (in hose trough) (19207) 11685834		EA	1
13	5330-00-899-4509	GASKET (96906) MS27030-9		EA	2
14	4730-00-643-6166	PLUG, QUICK DISCONNECT (96906) MS27029-17		EA	2
15	472001-067-5676	HOSE, TRANSFER (in hose trough) (19207) 11685835		EA	2
16	4730-00-640-6156	CAP QUICK DISCONNECT (96906) MS27028-17		EA	2
17	5330-00-899-4509	GASKET (96906) MS27030-9		EA	4
18	4730-00-640-6188	PLUG, WICK DISCONNECT (96906) MS27029-17		EA	2

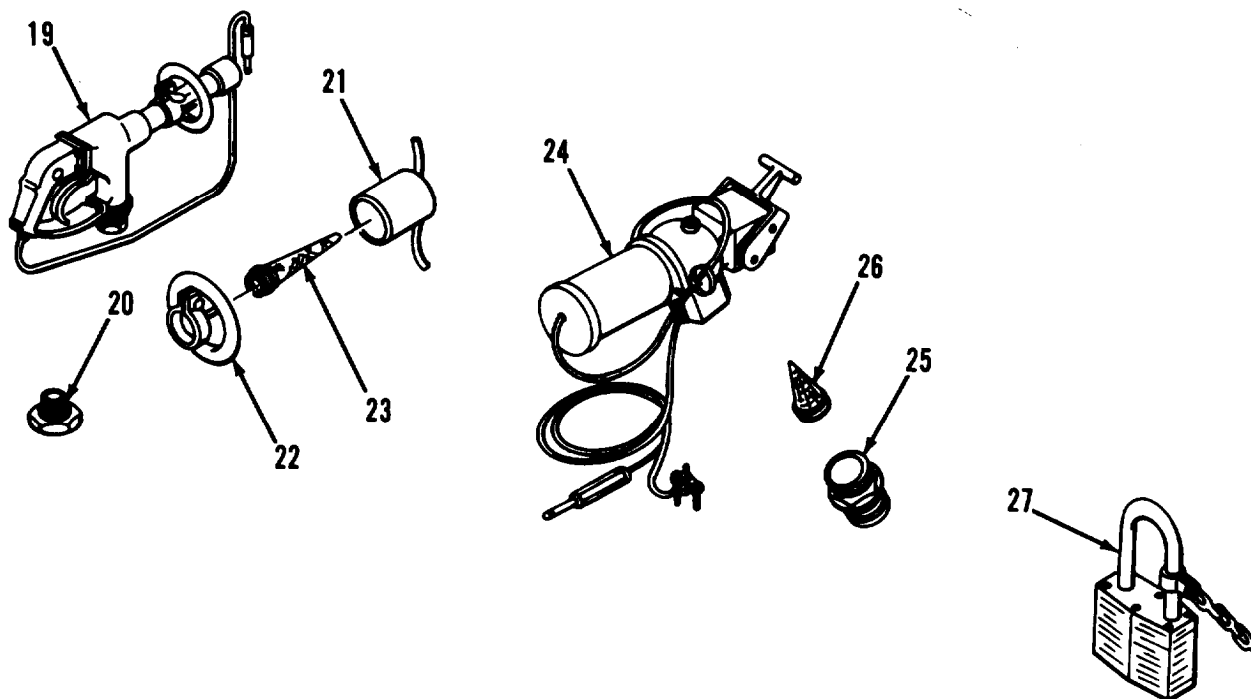

TA502378

(1) Illus Number	(2) National Stock Number	(3) Description FSCM and Part Number	Usable on Code	(4) U/M	(5) Qty Rqr
19	4930-01-022-7901	NOZZLE ASSEMBLY (tool box) (19207) 12275441-2	C72, C92, C73, C91	EA	1
20	4730-00-268-7479	BUSHING, PIPE SHOULDER (tool box) (96906) MS14315-22	C72, C92, C73, C91	EA	1
21	5340-01-170-4999	DUST CAP (tool box) (19207) 12275443	C72, C92, C73, C91	EA	1
22	2910-01-170-4937	FILLER NECK PROTECTOR (tool box) (use with bushing MS14315-22 only) (19207) 12275446	C72, C92, C73, C91	EA	1
23	4730-01-170-4973	STRAINER (tool box) (19207) 12275444	C72, C92, C73, C91	EA	1
24	4930-00-204-9452	NOZZLE, CLOSED-CIRCUIT (tool box) (97403) 13219E0494	C73, C91	EA	1
25	4930-01-091-9010	CONNECTOR, ACTUATOR (tool box) (use with nozzle 13219E0494 only) (19207) 12275292	C73, C91	EA	1
26	4730-01-084-5226	STRAINER (tool box) (use with nozzle 13219E0494 only) (32218) GTP-1534	C73, C91	EA	1
27	5340-00-912-4086	PADLOCK SET, W/CLEVIS AND CHAIN, COMPOSED OF 2 PADLOCKS AND 2 KEYS (96906) MS21313-160		EA	1

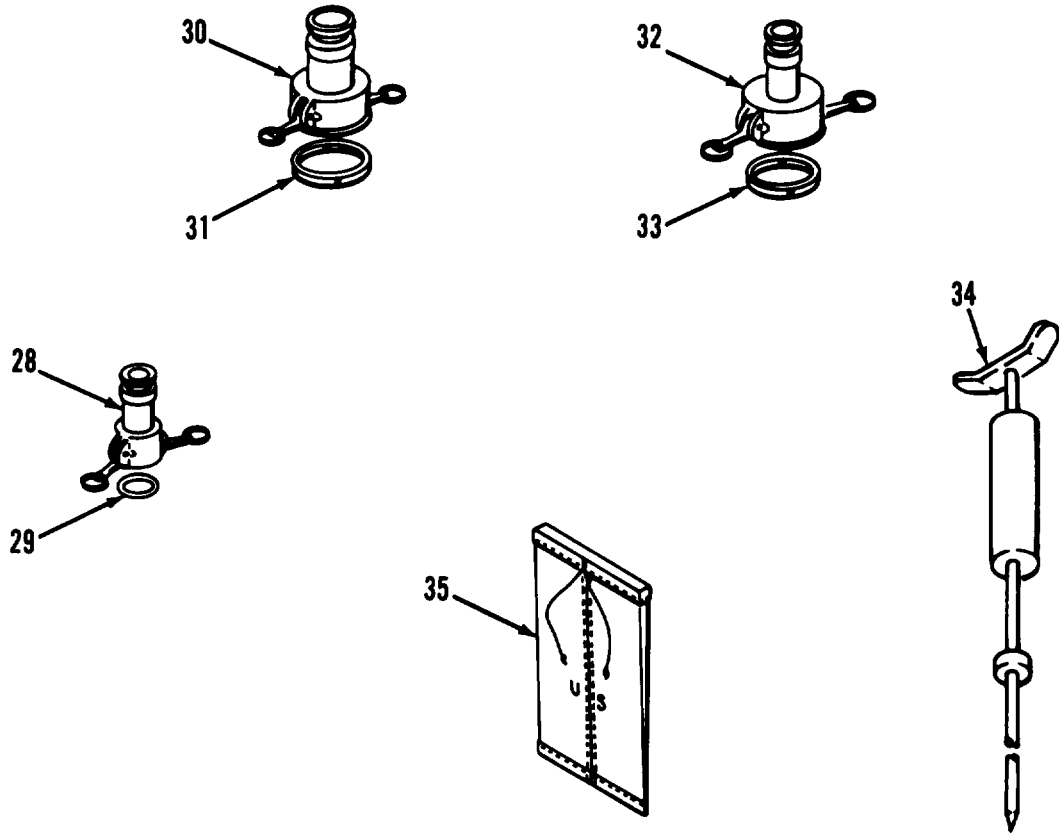

TA502379

(1) Illus Number	(2) National Stock Number	(3) Description FSCM and Part Number	Usable on Code	(4) U/M	(5) Qty Rqr
28	4730-00-951-3293	REDUCER, QUICK DISCONNECT (tool box) (96906) MS49000-1	C70, C90, C72, C92	EA	1
29	5310-00-812-2414	GASKET REDUCER (tool box) (96906) MS27030-6	C70, C90, C72, C92	EA	1
30	4730-00-951-3295	REDUCER, (QUICK DISCONNECT (tool box) (96906) MS49000-5	C70, C90, C72, C92	EA	1
31	5330-00-899-4509	GASKET, REDUCER (tool box) (96906) MS27030-9	C70, C90, C72, C92	EA	1
32	4730-01484-0560	REDUCER, QUICK DISCONNECT (tool box) (96906) MS49000-17	C70, C90, C72, C92	EA	1
33	5330-00-899-4509	GASKET, REDUCER (tool box) (98908) MS27030-9	C70, C90, C72, C92	EA	1
34	5975-01-050-5707	ROD, GROUND (stowage tuba) (97403) 13219E0462		EA	1
35	4730-01-098-9304	SLEEVE, HOSE (tool box) (19207) 12275301	C73, C91	EA	2



**APPENDIX D  
ADDITIONAL AUTHORIZATION LIST**

**Section I. INTRODUCTION**

**D-1. Scope**

a. This appendix lists additional items you are authorized for the support of the M967, M967A1, M969, M969A1, M970, and M970A1 semitrailers.

b. This list identifies items that do not have to accompany the semitrailer and that do not have to be turned in with it. These items are all authorized by CTA, MTOE, TDA or JTA.

numbers, descriptions, and quantities are provided to help you identify and request the additional items you require to support this equipment.

b. If item needed differs for different models of this equipment, the model is shown under the "Usable on Code" heading. These codes are identified as follows:

Code	Used On
C70, C90	Model M967, M967A1
C72, C92	Model M969, M969A1
C73, C91	Model M970, M970A1

**D-2. Explanation of Listing**

a. National stock numbers, FSCM and part

**Section II. ADDITIONAL AUTHORIZATION LIST**

(1) National Stock Number	(2) Description FSCM and Part Number	Usable on Code	(3) U/M	(4) Qty Auth
4930-00-516-0839	ADAPTER ASSY, GRAVITY FILL (96124) 780000-5		EA	1
2590-00-473-6331	BRACKET, GAS/WATER CAN (19207) 6566675		EA	1
7240-00-222-3088	CAN, GAS/WATER, 5 GAL. (81902) 14196P1		EA	1
4930-00-360-0710	COUPLING HALF, QUICK DISCONNECT, 1-1/2 IN. FUEL HOSE, 1 IN. MALE - 1 IN. FEMALE (81718) 633B11NAL		EA	1
5120-00-227-8074	EXTENSION, SOCKET WRENCH (19207) 11655788-1	C70, C72, C73	EA	1
5120-00-230-6385	HANDLE, SOCKET WRENCH (80064) 14U1502	C70, C72, C73	EA	1
2590-00-138-8434	KIT, VAPOR RECOVERY (19207) 1168593		EA	1
4930-00-117-4726	NOZZLE ASSEMBLY, CLOSED-CIRCUIT REFUELING, W/STRAINER (79326) CCN101/14		EA	1
4930-01-068-5100	NOZZLE, UNLEADED FUEL (33456) OPW11AP		EA	1
4730-00-889-2382	REDUCER, QUICK DISCONNECT, 1 IN. MALE - 1-1/2 IN. FEMALE (96906) MS49000-7		EA	1
4730-01-295-1842	REFUEL ON THE MOVE (ROM) ASSEMBLY (19207) 12356117	C72,C92	EA	1
4730-00-936-4584	CAP, 1.50 (96906) MS27028-10	C72, C92	EA	8

## Section II. ADDITIONAL AUTHORIZATION LIST - Continued

(1) National Stock Number	(2) Description FSCM and Part Number	Usable on Code	(3) U/M	(4) Qty Auth
4730-00-929-0787	CAP, 3.00 (96906) MS27028-15	C72, C92	EA	15
4730-00-640-6156	CAP, 4.00 (96906) MS27028-17	C72, C92	EA	3
4730-00-203-1010	COUPLING, 1.5 F to 1-1/2 NPT (96906) MS27026-9	C72, C92	EA	8
4210-00-257-5343	FIRE EXTINGUISHER (03670) K20E	C72, C92	EA	8
5330-00-360-05S5	GASKET, 1.50 (96906) MS27030-5	C72, C92	EA	8
5330-00-088-9166	GASKET 3.00 (96906) MS27030-8	C72, C92	EA	23
5330-00-899-4509	GASKET 4.0 (96906) MS27030-9	C72, C92	EA	4
5975-01-050-5707	GROUND ROD (97403) 13219E0462	C72, C92	EA	8
4720-00-555-8325	HOSE ASSEMBLY, 1.50 I.D. (81349) M370B05B2C3000	C72, C92	EA	8
4720-00-083-0048	HOSE ASSEMBLY 3.00 I.D. (73842) 543-419-3-50	C72, C92	EA	8
4930-00-471-0288	NOZZLE, FUEL (19207) 10896274	C72, C92	EA	8
4730-00-823-5316	PLUG, 1.50 (96906) MS27029-9	C72, C92	EA	8
4730-00-929-0790	PLUG, 3.00 (96906) MS27029-15	C72, C92	EA	15
4730-00-640-6188	PLUG, 4.00 (96906) MS27029-17	C72, C92	EA	2
4730-00-951-3293	REDUCER, 4.0/3.0 F/M (24869) MS49000-1	C72, C92	EA	1
4730-00-951-3296	REDUCER, 4.0/3.0 M/F (96906) MS49000-9	C72, C92	EA	1
4730-01-096-1039	TEE ASSEMBLY QUICK DISCONNECT 3.0 X 1.5 (97403) 13222E9884	C72, C92	EA	8
4730-00-075-2405	TEE ASSEMBLY QUICK DISCONNECT 4.0 (97403) 5-14-676C	C72, C92	EA	1
4820-01-098-4925	VALVE ASSEMBLY 3.00 (97403) 13222E9888	C72, C92	EA	6
5120-00-235-5879	SOCKET, WRENCH (93389) 5024	C70, C72, C73	EA	1



**APPENDIX E  
EXPENDABLE/DURABLE SUPPLIES AND MATERIALS LIST**

**Section I. INTRODUCTION**

**E-1. Scope**

This appendix lists expendable supplies and materials you will need to operate and maintain the M967, M967A1, M969, M969A1, M970, and M970A1 tank semitrailers. These items are authorized to you by CTA 50-970, Expendable/Durable Items (Except Medical, Class V Repair Parts, and Heraldic Items).

**E-2. Explanation of Columns**

*a. Column (1) —Item Number.* This number is assigned to the entry in the listing and is referenced in the narrative instructions to identify the material (e.g., “Use cleaning compound, (item 5, Appendix E)”).

*b. Column (2) —Level.* This column identifies the lowest level of maintenance that requires the listed item.

- C - Operator/Crew
- O - Unit Maintenance
- F - Direct Support Maintenance

*c. Column (3) —National Stock Number.* This is the National stock number assigned to the item; use it to request or requisition the item.

*d. Column (4) —Description.* Indicates the Federal item name and, if required, a description to identify the item. The last line for each item indicates the Federal Supply Code for Manufacturers (FSCM) in parenthesis, followed by the part number.

*e. Column (5) — Unit of Measure (U/M).* Indicates the measure used in performing the actual maintenance function. This measure is expressed by a two-character alphabetical abbreviation (e.g., pr, ea, in). If the unit of measure differs from the unit of issue, requisition the lowest unit of issue that will satisfy your requirements.

**Section II. EXPENDABLE/DURABLE SUPPLIES AND MATERIALS LIST**

(1) Item Number	(2) Level	(3) National Stock Number	(4) Description	(5) U/M
1	C	8040-00-262-9025	ADHESIVE: General Purpose (81348) MMM-A-1617  4 Ounce Tubs	oz
2	O	8040-00-225-4548	ADHESIVE: Sealant (81349) MIL-A-46106  12 Ounce Tube	oz
3	C	5350-00-192-5047 5350-00-192-5049 5350-00-192-5051	CLOTH: Abrasive (58536) A-A-1048  50 Sheets -80 Grit 50 Sheets-120 Grit 50 Sheets - 180 Grit	EA EA EA
4	C	5350-00-221-0872	CLOTH: Abraeive, Crocus (81348) P-C-458  60 Sheets	EA
5	O	8030-00-753-4953	COMPOUND: Anti-seize (81349) MIL-A-13881	LB
6	O	8030-01-044-5034	COMPOUND: Anti-seize (81349) MIL-T-5544	LB

Section II. EXPENDABLE/DURABLE SUPPLIES AND MATERIALS LIST-Continued

(1) Item Number	(2) Level	(3) National Stock Number	(4) Description	(5) U/M
7	C	5610-W-752-5555	COMPOUND: Flight Dock (81349) ML-D-23003	QT
a	F		COMPOUND: Lapping and Grinding (58536) A-A-1203	
		5350-00-193-1340	150 Grit - 1 Pound Can	LB
		5350-00-193-1341	220 Grit - 1 Pound Can	LB
		5350-00-193-1348	400 Grit - 1 Pound Can	LB
		5359-w-193-1349	500 Grit - 1 Pound Can	LB
9	F		CORROSION PREVENTIVE: Fingerprint Remover (81349) MIL-C-15074	
		8030-00-664-4017	1 Quart Can	QT
		8030-00-281-2338	1 Gallon Can	GL
		8030-00-252-8300	5 Gallon Can	GL
		8030-00-252-8301	65 Gallon Drum	GL
10	F		CORROSION PREVENTIVE: Grade 3 (81349) ML-C-16173	
		8030-00-244-1296	1 Gallon Can	GL
11	C		DRY CLEANING SOLVENT: Type II (81348) P-D-680	
		6850-00-110-4498	1 Pint Can	PT
		6850-00-274-5421	5 Gallon Can	GL
		6850-00-285-8011	55 Gallon Drum	GL
12	F		DYE: Prussian Blue (81349) MIL-P-30501	
		8010-00-889-9745	1 Ounce Tube	OZ
13	C		FUEL OIL, DIESEL: Arctic, DF-A (81348) W-F-800	
		9140-00-286-5282	5 Gallon Can	GL
		9140-00-286-5284	55 Gallon Drum	GL
14	C		FUEL OIL, DIESEL: Regular, DF-2 (81343) W-F-800	
		9140-00-286-5295	6 Gallon Can	GL
		9140-00-286-5296	55 Gallon Drum	GL
15	C		FUEL OIL, DIESEL: Winter, OF-1 (81348) W-F-800	
		9140-00-286-5287	5 Gallon Can	GL
		9140-00-286-5288	55 Gallon Drum	GL
16	F		GREASE: Aircraft (81349) ML-G-23827	
		9150-00-985-7247	6-1/2 Pound Can	LB

Section II. EXPENDABLE/DURABLE SUPPLIES AND MATERIALS LIST- Continued

(1) Item Number	(2) Level	(3) National StockNumber	(4) Description	(5) U/M
17	C	9150-01-197-7688 9150-01-197-7689 9150-01-197-7690 9150-01-197-7692 9150-01-197-7693	GREASE: Automotive and Artillery (81349) MIL-G-10924 2-1/4 Ounce Tube 6-1/2 Pound can 1-3/4 Pound Can 3 5 Pound Can 14 ouw Cartridge	OZ LB LB LB OZ
18	F	9150-00-935-9807	HYDRAULIC FLUID (81349) MIL-H-6083  1 Quart Can	QT
19	C	9150-00-889-3523	LUBRICATING OIL: (81349) MIL-P-48002	OZ
20	C.	9150-00-402-4478 9150-00-402-2372 9150-00-491-7197	LUBRICATING Oil Internal Combustion Engine, Arctic, OEA (81349) ha-L-46167  1 Quart Can 5 Gallon Can 55 Gallon Drum	QT GL GL
21	C	9150-00-189-6727 9150-00-186-6668 9150-00-191-2772	LUBRICATING OIL: OE/HDO 10W (81349) MIL-L-2104  1 Quart Can 5 Gallon Can 55 Gallon Drum	QT GL GL
22	C	9150-00-186-6681 9150-00-188-9858 9150-00-189-6729	LUBRICATING OIL: OE/HDO 30W (81349) MIL-L-2104  1 Quart Can 5 Gallon Can 55 Gallon Drum	QT GL GL
23	O	6505-00-133-8060	PETROLATUM: White	OZ
24	C	7920-00-205-1711	RAG: Wiping, Cotton and Cotton Synthetic (58536) A-A-531  50 Pound Bale	LB
28	O	8030-01-159-4844	SEALANT: Silicone, RTV (11862) 1052734  8-1/2 Ounce Tube	OZ
26	O	8030-01-054-0740	SEALING COMPOUND: Pipe, Anaerobic, with Teflon (05972) 592-31  50 Milliliter Tube	ML
27	O	9905-00-537-8954	TAG: Marker (81349) MIL-T-12755  50 Each	EA

Section II. EXPENDABLE/DURABLE SUPPLIES AND MATERIALS LIST- Continued

(1) Item Number	(2) Level	(3) National 'Stock' Number	(4) Description	(5) U/M
28	0	8030-00-889-3535	TAPe Anti-seize 1/2 inch Width (81349) MIL-T-27730A  260 Inch Roll	IN
29	0	5970-00-644-3167	TAPe: Insulation, Electrical (81348) HH-I-510  85 Foot Roll	FT

## APPENDIX F TORQUE LIMITS

**Table F-1. Standard Torque Specifications.**

USAGE	MUCH USED	MUCH USED	USED AT TIMES	USED AT TIMES
CAPSCREW DIAMETER AND MINIMUM TENSILE STRENGTH PSI (KG/SQ CM)	To 1/2-69,000 (4850.7000)	To 3/4 - 120,000 (8436.0000)	To 5/8 - 140,000 (9842.0000)	150,000 (10545.0000)
	To 3/4-64,000 (4499.2000)	To 1-115,000 (8084.5000)	To 3/4- 133,000 (9349.9000)	
	To 1-55,000 (3866.5000)			
QUALITY OF MATERIAL	INDETERMINATE	MINIMUM COMMERCIAL	MEDIUM COMMERCIAL	BEST COMMERCIAL
SAE GRADE NUMBER	1 or 2			
CAPSCREW HEAD MARKINGS				
<p>Manufacturer's marks may vary. These are all SAE Grade 5 (3-line).</p>				
CAPSCREW BODY SIZE (INCHES) - (THREAD)	TORQUE FT-LB (N•M)	TORQUE FT-LB (N•M)	TORQUE FT-LB (N•M)	TORQUE FT-LB (N•M)
1/4-20	5 (7)	8 (11)	10 (14)	12 (16)
-28	6 (8)	10 (14)		14 (19)
5/16-18	11 (15)	17 (23)	19 (26)	24 (33)
-24	13 (18)	19 (26)		27 (37)
3/8-16	18 (24)	31 (42)	34 (46)	44 (60)
-24	20 (27)	35 (47)		49 (66)
7/16-14	28 (36)	49 (66)	55 (75)	70 (95)
-20	30 (41)	55 (75)		78 (106)
1/2-13	39 (53)	75 (102)	85 (115)	105 (142)
-20	41 (56)	65 (115)		120 (163)
9/16-12	<b>51</b> (69)	110 (149)	120 (163)	155 (210)
-18	55 (75)	120 (163)		170 (231)
5/8-11	83 (113)	150 (203)	167 (226)	210 (285)
-18	95 (129)	170 (231)		240 (325)
3/4-10	105 (142)	270 (366)	260 (360)	375 (509)
-16	115 (156)	295 (400)		420 (570)
7/8-9	160 (217)	<b>395</b> (536)	440 (597)	<b>605</b> (820)
-14	175 (237)	435 (590)		675 (915)
1-8	235 (319)	590 (800)	660 (895)	910 (1234)
-14	250 (339)	660 (695)		990 (1342)

CAUTION: Capscrews threaded into aluminum may require reductions in torque of 30% or more, unless inserts are used.

NOTE: Do not use above values in place of those specified in the engine groups of this manual; special attention should be observed in case of SAE Grade 6, 7, and 8 capscrews,

1. Always use the torque values listed above when specific specifications are not available.
2. The above is based on use of clean and dry threads.
3. Reduce torque by 10% when engine oil is used as a lubricant.
4. Reduce torque by 20% if new plated capscrews are used.



INDEX

	Paragraph	Page
<b>A</b>		
Adapter, Oil Filter .....	7-25,7-49,7-68	7-17,7-34,7-40
Adapter, Recirculation .....	4-88	4-150
Administrative Storage .....	4-105,4106, 4-107,4-109	4170,4-170 4171,4-172
Activation .....	4-109	4-172
Auxiliary Equipment and Basic Issue Items .....	4-106	4-171
Correction of Shortcomings and Deficiencies .....	4-106	4-171
Exercising .....	4-107	4-171
Corrective Action .....	4-107	4-172
scheduled Semites .....	4-107	4-172
Vehicle Major Exercise .....	4-107	4-172
Cleaning .....	4-106	4-171
Painting .....	4-106	4-171
Reservation .....	4-106	4-171
Weatherproofing .....	4-106	4-171
Lubrication .....	4-106	4-171
Maintenance Services and Inspection .....	4-106	4-170
Rotation .....	4-107	4-172
Servicing .....	4-109	4-172
Storage Plan .....	4-106	4-170
Storage Site .....	4-106	4-170
Air Chamber, Brake .....	4-37,4-38, 6-8,6-9	4-88, 4-89, 6-4,6-5
<b>Air</b> Cleaner .....	3-18,474	3-39,4-124
<b>Air</b> Cooling shrouding .....	7-14,7-60,7-64	7-11,7-35,7-37
Air Shrouding Door .....	7-64	7-37
Air Shutter .....	7-14,7-60,7-64	7-12,7-35,7-37
Blower Housing .....	7-14,7-60,7-64	7-127-36,7-37
Bottom Cylinder Pan .....	7-14,7-60	7-12, 7-35
Bracket Assembly .....	7-64	7-37
Grille .....	7-64	7-37
Rear CylinderHousing .....	7-60	7-35
Shutter Assembly .....	7-64	7-37
Top Housing Cover .....	7-14,7-60	7-11,7-36
Air Cooling System .....	7-3	7-1
Aircraft Fuel Servicing .....	2-18	2-39
Aircraft Overwing/Closed-Cirait Fuel Dispensing Operation .....	2-18	2-42
Aircraft Single Point Underwing Fuel Dispensing Operation .....	2-18	2-40
Defueling Operation:		
1 1/2-inch Hose .....	2-18	2-45
2 1/2-inch Hose .....	2-18	2-43
Fuel Sampling .....	2-18	2-39

INDEX-Continued

	Paragraph	Page
<b>Aircraft Fuel Servicing (Con't):</b>		
<b>Recirculation Operation</b>		
1 1/2-inch Hose .....	2-18	2-49
2 1/2-inch Hose .....	2-18	2-48
Air Lines, Valves, and Fittings .....	4-48	4-98
Air Line Fittings .....	4-48	4-101
Nylon Tubing .....	4-48	4-98
Air Reservoirs .....	3-7,4-45	3-35,4-96
Air Shutter Test and Adjustment .....	7-81	7-62
Thermo Unit, Adjustment .....	7-81	7-62
Thermo Power Unit Assembly Test .....	7-81	7-62
Alternator, Engine .....	4-78, 7-79	4-129,7-58
Alternator Drive Belt .....	4-78	4-131
M967, M969, and M970 .....	6-20	6-12
M967A1, M969A1, and M970A1 .....	4-78	4-131
Alternator Pulley .....	4-78	4-131
Test and Adjustment .....	7-91	7-73
Angle Valve (M969, M969A1, M970 and M970A1) .....	4-86, 8-15	4-142,8-24
Aqua-Glo Probe and Adapter (M969 and M969A1) .....	5-26	5-31
<b>Axle:</b>		
M967, M969, and M970 except M970 SN TC-0843, TC-0844, and TC-103 thru TC-178 .....	5-14	5-19
M967A1, M969A1, and M970A1 including M970 SN TC-0843, TC-0844, and TC-103 thru TC-178 .....	5-15	5-19
<b>B</b>		
Bar, Buss .....	4-81	4-136
Batteries, Terminals, and Cables .....	3-6,4-23	3-34,4-56
Charging Battery .....	4-23	4-59
Hydrometer Readings .....	4-23	4-58
Specific Gravity .....	4-23	4-58
Water Addition .....	4-23	4-57
Before Operation Service .....	2-2	2-1
Block, Crankcase, Cylinder Head, and .....	4-71	4-121
Board Assembly, Landing Gear .....	4-55	4-114
Body Parts, Miscellaneous .....	4-57	4-116
Body, Tank .....	4-59	4-119
<b>Bogie Assembly:</b>		
M967, M969, and M970 except M970 SN TC-0843, TC-0844, and TC-103 thru TC-178 .....	5-16	5-20
M967A1, M969A1, and M970A1 including M970 SN TC-0843, TC-0844, and TC-103 thru TC-178 .....	5-17	5-21
Brackets, Splash Plates, and Mudflaps .....	4-56	4-114
Brake Adjusting Parts, Brake Plungers and (M967, M969, M970 except M970 SN TC-0843, TC-0844, and TC-103 thru TC-178) .....	4-36	4-85
<b>Brake Air Chamber:</b>		
(M967, M969, and M970 except M970 SN TC-0843, TC-0844, and TC-103 thru TC-178) Standard .....	6-8	6-4
(M967, M969, and M970 except M970 SN TC-0843, TC-0844, and TC-103 thru TC-178) Fail-Safe Unit .....	6-9	6-5



INDEX-Continued

	Paragraph	Page
<b>Brake Air Chamber, Test and Replacement, Standard</b>		
M967, M969, M970 except M970 SN TC-0843, TC-0844, and TC-103 thru TC-178 .....	4-37	4-88
M967A1, M969A1, M970A1 including M970 SN TC-0843, TC-0844, and TC-103 thru TC-178 .....	4-38	4-89
<b>Brake Chamber-Fail-Safe Test and Replacement</b>		
M967, M969, M970 except M970 SN TC-0843, TC-0844, and TC-103 thru TC-178) .....	4-39	4-90
M967A1, M969A1, M970A1 including M970 SN TC-0843, TC-0844, and TC-103 thru TC-178) .....	440	4-92
<b>Brake Camshaft (M967A1, M969A1, M970A1 including M970     SN TC-0843, TC-0844, and TC-103, thru TC-178) .....</b>	4-42	4-93
<b>Brake Drums. ....</b>	6-7	6-4
<b>Brake Plungers and Brake Adjusting Parts (M967, M969, M970 except     M970 SN TC-0843, TC-0844, and TC-103 thru TC-178) .....</b>	4-36	4-85
Adjusting Plunger Assembly .....	4-36	4-85
Anchor (Solid) Plunger .....	4-36	4-85
<b>Brake Plunger, Non-adjusting (M967, M969, M970 except M970     SN TC-0843, TC-0844, and TC-103 thru TC-178) .....</b>	6-10	6-6
<b>Brake Shoes .....</b>	6-6	6-4
<b>Brake System</b>		
M967, M969, and M970 except M970 SN TC-0843, TC-0844, and TC-103 thru TC-178 .....	4-28,4-31	4-73,4-74
Actuation .....	4-31	4-75
Automatic Adjusters .....	4-31	4-75
Brake Air System .....	4-31	4-75
Brake Interlock (M970 except M970 SN TC-0843, TC-0844, and TC-103 thru TC-178) .....	4-31	4-77
Emergency Relay Valve .....	4-31	4-75
Fail-Safe Units .....	4-31	4-75
Service Brake .....	4-31	4-75
M967A1, M969A1, and M970A1 including M970 SN TC-0843, TC-0844, and TC-103 thru TC-178 .....	4-29,4-32	4-73,4-77
Actuation .....	4-32	4-77
Brake Air System .....	4-32	4-77
Brake Interlock (M970A1 including M970 SN TC-0843, TC-0844, and TC-103 thru TC-178) .....	4-32	4-80
Emergency Relay Valve .....	4-32	4-78
Fail-Safe Units .....	4-32	4-78
Service Brake .....	4-32	4-78
Slack Adjusters .....	4-32	4-80
<b>Brake Wedge Assembly (M967, M969, M970 except M970     SN TC-0843, TC-0844, and TC-103 thru TC-178) .....</b>	4-35	4-84
<b>Breakaway fitting (M970 and M970A1) .....</b>	3-13	3-36
<b>Bulk Haul and Fuel Servicing Operations Not Involving Use of</b>		
Engine and Pump (All Models) .....	2-13	2-20
Bottom Loading (Nonfiltered) .....	2-13	2-23
Gravity Unload .....	2-13	2-24
Loading With a Hose .....	2-13	2-22
Loading With Rack or Stand .....	2-13	2-20
Top Loading .....	2-13	2-20
Water Drain .....	2-13	2-24
<b>Bulk Transfer Hose Assembly .....</b>	4-62	4-120
<b>Bumpers, and Brackets, Frame .....</b>	6-11	6-7

INDEX-Continued

	Paragraph	Page
Buss Bar .....	4-81	4-136
Buss Fuse .....	4-81	4-136
Butterfly Valve .....	4-86,8-13	4-143,8-22
<b>C</b>		
Cabinet Door (M969, M969A1, M970, M970A1) .....	6-16	6-7
Door Sprigs (M970 and M970A1) .....	6-16	6-8
Latching Cable (M970 and M970A1) .....	6-16	6-7
Trip Bar (M970 and M970A1) .....	6-16	6-8
Cabinets and Cabinet Doors .....	3-9	3-35
Hose Reel Cabinet (M969, M969A1, M970, and M970A1) .....	3-9	3-35
Piping Assembly .....	3-9	3-35
Cabinet, Hose Reel (M969, M969A1, M970, M970A1) .....	5-22,6-15	5-27,6-7
Cabinet, Piping Control .....	6-13	6-7
Cables, Batteries, Terminal, and .....	3-6,4-23	3-34,4-56
Camshaft and Tappets .....	7-34,7-40	7-25,7-30
Centrifugal Pump .....	4-90,5-19	4-153,5-23
Charging System .....	7-7	7-5
Chassis Wiring .....	4-12	4-36
Composite Light and Connector Lead Assemblies .....	4-12	4-36
Conduit .....	4-13	4-41
Connector Lead Assembly .....	4-12	4-36
Front Marker Light Lead Assemblies .....	4-12	4-39
Rear Composite Light Lead Assembly .....	4-12	4-36
Receptacle Assembly .....	4-12	4-36,4-40
Right Side Marker Light Lead Assembly .....	4-12	4-36,4-39
Triple Marker Light Lead Assembly .....	4-12	4-36
wiring Harness .....	4-12	4-36,4-40
Check Valve (M967, M967A1, M969, and M969A1) .....	8-14	8-23
Circuit Breaker .....	4-17	4-50
Cleaner, Air .....	3-18,4-74	3-39,4-124
Cleaning - General .....	7-62	7-36
Cleaning Tank Interior, Inspecting and .....	4-102	4-169
Closed-Circuit Nozzle (M970 and M970A1) .....	3-16,8-25	3-38,8-36
Composite Tail Stop Lights .....	4-15	4-44
Compression Test,Cylinder Head, On Equipment .....	7-89	7-69
Conduit for Chassis Wiring .....	4-13	4-41
Connecting Rods, Pistons and .....	7-31,743,7-73	7-21,7-32,7-51
Control Panel Assembly .....	6-14	6-7
Control Panel Light .....	4-26	4-67
Control Panel- Wiring Harness and Conduit .....	4-25	4-65
wiring .....	4-25	4-65
Control Panel to Engine Junction Box Conduit .....	4-25	4-66
Control Panel Wiring Harness .....	4-25	4-65

INDEX-Continued

	Paragraph	Page
Control Tubing .....	4-92	4-153
Deadman Control Circuit .....	4-92	4-159
Fittings .....	4-92	4-163
Precheck and Load/Unload Circuit (M967, M967A1, M969 and M969A1) .....	4-92	4-153
Float valve .....	4-92	4-159
Load/Unload Valve .....	4-92	4-159
Recheck Valve .....	4-92	4-154
Precheck Circuit (M970 and M970A1) .....	4-92	4-153
Float Valve .....	4-92	4-153
Recheck Valve .....	4-92	4-153
Coupling Semitrailer to Towing Vehicle .....	2-3	2-1
Crankcase, Cylinder Head, and Block .....	4-71	4-121
Crankshaft .....	7-77	7-55
Bearings .....	7-77	7-55
Rear Oil Seal .....	7-77	7-55
Crankshaft and Main Bearings .....	7-36	7-25
Crankshaft and Main Bearing Blocks .....	7-38	7-26
Cross Tube, Trunnion M967, M969, and M970 except M970 SN TC-0843, TC-0844, and TC-103 thru T-178 .....	6-4	6-2
M967A1, M969A1, and M970A1 including M970 SN TC-0843, TC-0844, and TC-103 thru TC-178 .....	6-5	6-3
Cylinder Head .....	4-71,7-72	4-121,7-48
Cylinder Heads Casting and Reeker Arm Studs .....	7-72	7-48
Valve Guide and Valve .....	7-72	7-50
Valve Seat .....	7-72	7-50
Valve Spring .....	7-72	7-51
Cylinder Head and Rocker Arms .....	7-30,7-44	7-20,7-32
Cylinder Head Compression Test, On Equipment .....	7-89	7-69

D

DC Volts Scale .....	4-11	4-34
Deadman Control Valve (M970 and M970A1) .....	8-21	8-32
Deadman Hose Reel (M970 and M970A1) .....	5-28	5-32
Deadman Release Valve .....	4-94	4-163
Destruction of Army Materiel to Prevent Enemy USC .....	1-4	1-1
Diagrams Electrical .....	4-8	4-29
Differences Between Models .....	1-8	1-1
M967 and M967A1 .....	1-8	1-1
M969 and M969A1 .....	1-8	1-13
M970 and M970A1 .....	1-8	1-13
Recirculation System .....	1-8	1-13
Underwing Refueling System .....	1-8	1-13
Overwing Refueling System .....	1-8	1-13

INDEX-Continued

	Paragraph	Page
Differences Between Models (Con't)		
Upgrades to M967, M969, and M970 .....	1-8	1-13
M967A1, M969A1, and M970A1 .....	1-8	1-13
M970 (Marine Corps) .....	1-8	1-13
Dispensing Piping .....	4-91	4-153
Draining Tank .....	4-100	4-167
Drums, Brake .....	6-7	6-4
<b>E</b>		
Electrical Diagrams .....	4-8	4-29
Emergency Relay Valve .....	4-44	4-95
Emergency Valve .....	8-20	8-31
Control and Cable .....	4-51	4-110
Control Cables .....	6-18	6-11
Vent .....	8-8	8-16
Engine .....	5-20	5-24
Engine Alternator .....	4-78	4-129
Drive Belt .....	4-78	4-131
Drive Belt (M967A1, M969A1, and M970A1) .....	4-78	4-131
Pulley .....	4-78	4-131
Engine and Pump Assembly .....	5-18	5-21
Engine Controls and Instruments .....	2-9	2-7
Control Panel Light .....	2-9	2-8
Engine Switch .....	2-9	2-7
Engine Throttle .....	2-9	2-8
Filter/Separator Gage (M969, M969A1, M970, and M970A1) .....	2-9	2-8
Fuel Pressure Gage .....	2-9	2-8
Hourmeter .....	2-9	2-8
Indicator Light .....	2-9	2-7
Oil Pressure Gage .....	2-9	2-8
Reheater Switch .....	2-9	2-7
Pump Pressure Gage .....	2-9	2-8
Starter Switch .....	2-9	2-8
Tachometer .....	2-9	2-8
Voltmeter .....	2-9	2-8
Engine Fuel System .....	4-73	4-122
Bleeding .....	4-73	4-124
Draining Fuel Tank .....	4-73	4-123
Draining Water from Fuel System .....	4-73	4-123
Electric Fuel Pumps .....	4-73	4-124
Fuel Lines and Fittings .....	4-73	4-124
Fuel Tank .....	4-73	4-124

## INDEX-Continued

	Paragraph	Page
Engine Fuel System (Con't)		
Fuel Filters . . . . .	4-73	4-123
Electric Fuel Pump Filter . . . . .	4-73	4-123
Primary and Secondary Fuel Filters . . . . .	4-73	4-124
Testing Electric Fuel Pumps on Equipment . . . . .	4-73	4-122
Engine Junction Box . . . . .	4-19	4-52
Engine Junction Box and Electrical Wiring . . . . .	7-21,7-53	7-16,7-34
Engine Lubrication System . . . . .	4-72	4-122
Engine Muffler/Exhaust . . . . .	4-77	4-127
Engine Operation . . . . .	2-10	2-9
Engine Preheater Solenoid . . . . .	4-18	4-52
Engine Throttle Linkage and Cable . . . . .	4-75	4-125
Engine Servicing, General . . . . .	4-70	4-121
Engine Wiring . . . . .	4-16	4-45
Exhaust Manifold . . . . .	7-22,7-52	7-16,7-34
Extreme Cold Weather Operation . . . . .	2-20	2-53
Extreme Hot Weather Operation . . . . .	2-21	2-53
<b>F</b>		
Fabricated Tools and Equipment. . . . .	4-4,5-3	4-2,5-1
Fail-Safe Brakes . . . . .	2-4	2-3
Filtered Fuel Servicing Operations (M969 and M969A1) . . . . .	2-16	2-33
Filtered Bulk Deliver . . . . .	2-16	2-33
Filtered Fuel dispensing . . . . .	2-16	2-35
Fuel Sampling . . . . .	2-16	2-36
Filtered Fuel Servicing Operations (M970 and M970A1) . . . . .	2-17	2-36
Filtered Bulk Delivery . . . . .	2-17	2-38
Filtered Self-Load . . . . .	2-17	2-36
Filter/Separator . . . . .	4-83	4-139
Automatic Drain Valve (M969, M969A1, M970 and M970A1) . . . . .	8-18	8-26
Diaphragm Valve . . . . .	8-18	8-27
Separator Valve . . . . .	8-18	8-29
Elements and Fuses . . . . .	4-83	4-139
Manual Drain Valve (M969, M969A1, M970 and M970A1) . . . . .	8-19	8-30
Operation (M969, M969A1, M970, M970A1) . . . . .	2-15	2-32
Sump . . . . .	3-12	3-36
Fittings, Air Lines, Valves, and . . . . .	4-48	4-98
Fire Extinguisher Mounting Bracket . . . . .	4-68	4-121
Float Assembly . . . . .	8-9	8-18
Flushing . . . . .	4-103	4-170
Flywheel Assembly . . . . .	7-27,7-47	7-18,7-33
Frame, Bumpers, and Brackets . . . . .	6-11	6-7

## INDEX-Continued

	Paragraph	Page
Fuel Handling (All Models) . . . . .	2-8	2-5
Bonding and Grounding . . . . .	2-8	2-5
Fire Extinguishers . . . . .	2-8	2-6
On-vehicle Equipment . . . . .	2-8	2-6
Safety Precautions . . . . .	2-8	2-5
Spills and Leaks . . . . .	2-8	2-7
Vapor Recovery . . . . .	2-8	2-7
Fuel Filter . . . . .	4-73	4-123
Fuel Injection Pump . . . . .	7-26,7-48, 7-69,7-86	7-18,7-33, 7-41,7-64
On Equipment Adjustment and Timing . . . . .	7-86	7-64
Timing . . . . .	7-86	7-64
Timing Method 1 . . . . .	7-86	7-65
Timing Method 2 . . . . .	7-86	7-66
Test, After Rebuilding . . . . .	7-86	7-64
Fuel Injectors . . . . .	7-28,7-46, 7-70	7-19,7-32, 7-45
Fuel Level Gage . . . . .	4-64	4-120
Fuel Lines . . . . .	7-19,7-55	7-14,7-34
Fuel Servicing, Aircraft . . . . .	2-18	2-39
Fuel Stop Solenoid . . . . .	7-20,7-54, 7-67,7-85	7-16,7-34, 7-39,7-63
Fuel Stop Solenoid . . . . .	4-22	4-54
Fuel System . . . . .	4-73,7-4	4-123,7-2
Fueling/Defueling Operations. . . . .	2-12	2-19
Changing Fuels . . . . .	2-12	2-20
Operation Summary . . . . .	2-12	2-19
Buss, Fuse . . . . .	4-81	4-136
<b>G</b>		
Gage, Fuel Level . . . . .	4-64	4-120
Gages, and Indicator Light, Switches . . . . .	4-24	4-59
Gate Valve . . . . .	8-10	8-20
Valves Band F, All Models . . . . .	8-10	8-20
Valve P, M970and M970A1 . . . . .	8-12	8-21
Valve R, M970 and M970A1 . . . . .	8-11	8-21
Gear Cover Assembly . . . . .	7-32,7-42,7-75	7-24,7-31,7-54
General Maintenance . . . . .	5-7,5-8	5-11,5-11
Glow Plugs . . . . .	4-21	4-54
Governor Assembly . . . . .	4-76	4-127
Governor Sensitivity Adjustment (No Engine Surge) . . . . .	4-76	4-127
Governor Cup . . . . .	7-33,7-41,7-76	7-24,7-31,7-55
Governor Linkage . . . . .	7-18,7-56,7-66	7-14,7-34,7-39

## INDEX-Continued

	Paragraph	Page
Governor Speed and Sensitivity Adjustment.....	7-84	7-63
Governor System .....	7-8	7-5
Grounding Rod .....	4-63	4-120
Grounding Studs. ....	4-57	4-116
<b>H</b>		
Heaters, Manifold .....	4-20	4-53
High Temperature Switch .....	4-22,7-17, 7-57,7-83	4-54,7-13, 7-34,7-63
Fuel Stop Solenoid .....	4-22	4-56
High Temperature Switch .....	4-22	4-55
Low Oil Pressure Switch .....	4-22	4-56
Hose Coupling, 2 1/2-Inch .....	8-26	8-36
Hose Reel, Deadman (M970 and M970A1) .....	5-28	5-32
Hose Reels .....	3-10	3-36
2 1/2-inch .....	8-5	8-7
1 1/4-inch and 1 1/2-inch (M969, M969A1, M970 and M970A1) .....	8-6	8-11
Hose Reel Assembly - 1 1/4-Inch and 1 1/2-Inch .....	5-24	5-30
Hose Reel Assembly -2 1/2-Inch .....	5-23	5-28
Hose Reel Cabinet (M969, M969A1, M970, M970A1) .....	5-22,6-15	5-27,6-7
Hose Reel Hoses and Fittings.....	4-89	4-151
1 1/4-inch Hoses (M969 and M969A1) and 1 1/2-inch Hose (M970 and M970A1) .....	4-89	4-151
2 1/2-inch Hose(M970 and M970A1) .....	4-89	4-151
Deadman Hose Reel (M970 and M970A1) .....	4-89	4-151
Hose Reel Wiring .....	4-27	4-68
Hoses and Fittings, Hose Reel .....	4-89	4-152
Hose Troughs .....	3-8,6-12	3-35,6-7
<b>I</b>		
Identification and Instruction Plates .....	1-11,4-67	1-16,4-121
Identification of Valves, Piping, and Dispensing Components .....	2-11	2-10
Bulk Fuel Servicing Hoses .....	2-11	2-16
Emergency Valve Operation .....	2-11	2-16
Filter/Separator (M969, M969A1, M970, and M970A1) .....	2-11	2-13
Deadman Release Plunger (M970 and M970A1) .....	2-11	2-13
Hose Reel Cabinet (M969, M969A1, M970, and M970A1) .....	2-11	2-13
Hose Reels .....	2-11	2-14
Meter(s) .....	2-11	2-13
Rewinding Hose .....	2-11	2-14
Static Reel (M969 and M969A1) .....	2-11	2-16
Valve M .....	2-11	2-13
Valve N .....	2-11	2-13
Valves P and R .....	2-11	2-13
Valve S (M970 and M970A1) .....	2-11	2-13
Unwinding Hose .....	2-11	2-14

INDEX-Continued

	Paragraph	Page
Identification of Valves, Piping, and Dispensing Components (Con't)		
Loading Precheck (All Models) .....	2-11	2-17
Load/Unload Selector (M967, M967A1, M969, and M969A1) .....	2-11	2-19
Load Position .....	2-11	2-19
Unload Position .....	2-11	2-19
Identification of Valves, Piping, and Dispensing Components:		
Nozzles .....	2-11	2-16
Piping Control Assembly .....	2-11	2-11
Static Reel .....	2-11	2-12
Valve A, Emergency Valve Operator (All Models) .....	2-11	2-11
Valve B (All Models) .....	2-11	2-11
Valve C (M970,M970A1) .....	2-11	2-11
Valve D, Precheck (All Models) .....	2-11	2-11
Valve E (M967, M967A1, M969, M969A1) .....	2-11	2-12
Valve E (M970, M970A1) .....	2-11	2-12
Valve F (All Models) .....	2-11	2-12
Valve G (All Models) .....	2-11	2-12
Valve H (All Models) .....	2-11	2-12
Valve J (All Models) .....	2-11	2-12
Valve K (M969, M969A1, M970, and M970A1) .....	2-11	2-12
Indicator Light, Switches, Gages, and .....	4-24	4-59
Inspecting and Cleaning Tank Interior .....	4-102	4-169
Inspecting and Servicing the Equipment .....	4-1	4-1
Instruction Plates, Identification and .....	1-11,4-67	1-16,4-121
Instruments, Engine Controls and .....	2-9	2-7
Intake Manifold Assembly .....	4-82	4-137
<b>J</b>		
Jacking Procedures .....	2-7	2-5
Junction Box, Engine .....	4-19	4-52
Junction Box and Electrical Wiring, Engine .....	7-21,7-53	7-16,7-34
<b>K</b>		
Kingpin, Upper Coupler Plate.....	5-10	5-14
<b>L</b>		
Ladder and Drain .....	4-61	4-120
Landing Gear .....	4-54	4-112
Landing Gear Leg Assembly .....	4-54,6-17	4-112,6-9
Landing Gear Shoe .....	4-54	4-112
Light, Control Panel .....	4-26	4-67
Lights, Marker .....	4-14	4-41
Low Oil Pressure Switch .....	4-22	4-56
Lubrication .....	3-1	3-1
Lubrication System .....	4-72,7-5	4-122,7-3



INDEX-Continued

	Paragraph	Page
<b>M</b>		
Main Bearings, Crankshaft and.....	7-36	7-27
Maintenance Allocation Chart . . . . .	Appendix B	B-1
Maintenance Forms and Records . . . . .	1-2,3-2	1-1,3-21
Manhole and Fill Cover . . . . .	4-60	4-119
Manifold Drain Valve . . . . .	8-17	8-26
Manifold Heaters . . . . .	4-20	4-53
Marker Lights . . . . .	4-14	4-41
Meter (M970 and M970A1) . . . . .	8-7	8-15
Meter Assembly		
M969 and M969A1 . . . . .	5-25	5-30
M970 and M970A1 . . . . .	5-27	5-32
Meter Inlet Pressure Gage.....	4-95	4-164
Miscellaneous Body Parts . . . . .	4-57	4-116
Grounding Studs . . . . .	4-57	4-116
Vent Caps . . . . .	4-57	4-116
Motor, Starter . . . . .	4-79	4-134
Mounting Bracket, Fire Extinguisher . . . . .	4-68	4-121
Mudflaps, Brackets, Splash Plates, and . . . . .	4-56	4-114
Muffler/Exhaust, Engine . . . . .	4-77	4-127
Multimeters . . . . .	4-9	4-29
<b>N</b>		
Non-adjusting Brake Plunger (M967, M969, and M970) . . . . .	6-10	6-6
Nonfiltered Fuel Servicing Involving Use of Engine and Pump . . . . .	2-14	2-27
Bulk Delivery (All Models) . . . . .	2-14	2-29
Hose Evacuation (M970 and M970A1) . . . . .	2-14	2-31
Nonfiltered Dispensing (M969 and M969A1) . . . . .	2-14	2-30
Self-Load (M967, M967A1, M969, and M969A1) . . . . .	2-14	2-27
Nozzle, Adapter, and Sampling Bags (M970 and M970A1) . . . . .	4-65	4-120
Nozzle Assembly Test and Adjustment . . . . .	7-87	7-68
Nozzle, Closed-Circuit (M970 and M970A1) . . . . .	3-16,8-25	3-38,8-36
Nozzle, Overwing (M970 and M970A1).. . . . .	3-15,8-23	3-37,8-33
Nozzle, Underwing (M970 and M970A1) . . . . .	3-17,8-24	3-39,8-34
Nozzle, Vehicle . . . . .	8-22	8-33
Nozzle, Vehicle (M969 and M969A1) . . . . .	3-14,4-97	3-36,4-165
<b>O</b>		
Ohms Scale . . . . .	4-10	4-30
Oil Bypass Valve . . . . .	7-74	7-53
Oil Cooler and Lines . . . . .	7-15,7-59	7-13,7-35
	7-65	7-39
Oil Filler Tube . . . . .	7-23,7-51	7-16,7-34
Oil Filter Adapter . . . . .	7-25,7-49,7-68	7-17,7-34,7-40

INDEX-Continued

	Paragraph	Page
Oil Lines . . . . .	7-24,7-50	7-17,7-34
Oil pressure Switch . . . . .	4-22	4-54
Off Pump . . . . .	7-35,7-39	7-27,7-30
Operating Towing Vehicle with Semitrailer Coupled . . . . .	2-5	2-4
Operation on Unusual Terrain. . . . .	2-23	2-53
Overwing Nozzle (M970 and M970A1) . . . . .	3-15,8-23	3-37,8-33
<b>P</b>		
Painting and Stenciling . . . . .	4-7	4-22
Parking Brake Control Valve.....	4-47	4-97
Piping Control Cabinet . . . . .	6-13	6-7
Piping, Dispensing . . . . .	4-91	4-153
Piping Strainer . . . . .	4-87	4-150
Piping, Vapor Recover . . . . .	4-98	4-165
Pistons and Connecting Rods.....	7-31,7-73,7-43	7-21,7-51,7-32
Power Train . . . . .	7-9	7-6
Precheck and/orLoad/Unload Valve . . . . .	4-93	4-163
Preparation of Equipment for Administrative Storage . . . . .	4-106	4-170
Preparation of Equipment for Shipment . . . . .	4-110	4-172
Pressure Protection Valve . . . . .	4-46	4-96
Preventive Maintenance Checks and Services (PMCS): . . . . .	3-3	3-21
Operator/Crew . . . . .	4-5	4-5
Unit . . . . .	4-5	4-5
Procedures for Common Components and Miscellaneous Items . . . . .	4-108	4-172
Air Lines and Reservoirs . . . . .	4-108	4-172
Seals . . . . .	4-108	4-172
Tires . . . . .	4-108	4-172
Pump, Centrifugal . . . . .	4-90,5-19	4-153,5-23
Pump, 4-Inch (M967, M967A1, M969,and M969A1) . . . . .	8-3	8-1
Air Leakage last . . . . .	8-3	8-1
Bearings . . . . .	8-3	8-3
Gaskets and Seals . . . . .	8-3	8-3
Impeller and Wear Plate . . . . .	8-3	8-3
Impeller Shaft . . . . .	8-3	8-3
Mechanical Seal . . . . .	8-3	8-3
Pump, Fuel Injection . . . . .	7-26,7-69,7-86	7-18,7-41,7-64
Pump, Fuel Injector . . . . .	7-48	7-33
Pump, 3-Inch (M970 and M970A1) . . . . .	8-4	8-5
Air Leakage Test . . . . .	8-4	8-5
Impeller and Wear Ring . . . . .	8-4	8-5
Intermediate Housing Assembly . . . . .	8-4	8-7
Seal Plate and Mechanical Seal.. . . .	8-4	8-5
Pump Bypass Valve (M970 and M970A1) . . . . .	8-16	8-25

INDEX-Continued

	Paragraph	Page
Pump, Oil .....	7-35,7-39	7-27,7-30
Purging Tank .....	4-101	4-167
Chemical Method .....	4-101	4-168
Forced Air .....	4-101	4-169
Steam Method .....	4-101	4-168
<b>Q</b>		
Quality Assurance/Quality Control (QA/QC) .....	1-6	1-1
<b>R</b>		
Recalibration, Tachometer .....	7-82	7-63
Recirculation Adapter .....	4-88	4-150
References .....	Appendix A	A-1
Reflectors .....	4-66	4-121
Refuel on the Move (ROM) (M969 and M969A1) .....	2-19	2-51
Releases of Fail-Safe Brakes .....	2-4	2-3
Manual Release (Caging) (M967, M969, and M970 except M970 SN TC-0843, TC-0844, and TC-103 thru TC-178) .....	2-4	2-3
Manual Release (Caging) (M967A1, M969A1, and M970A1 including M970 SN TC-0843, TC-0844, and TC-103 thru TC-178) .....	2-4	2-4
Reserve Air Release .....	2-4	2-3
Removal of Equipment from Administrative Storage .....	4-109	4-172
Repair Parts .....	4-3,5-1	4-2,5-1
Reporting of Equipment Improvement Recommendations (EIRs) .....	1-5	1-1
Reservoirs, Air .....	3-7,4-45	3-35,4-96
Rocker Arm Covers .....	7-29,7-45,7-71	7-20,7-32,7-47
Rocker Arms, Cylinder Head and .....	7-30,7-44	7-20,7-32
<b>S</b>		
Sensor, Tachometer (M967, M969, and M970 except M970 SN TC-0843, TC-0844, and TC-103 thru TC-178) .....	7-16,7-58	7-13,7-35
Service and Emergency Couplings, Air Lines, and Lines .....	4-43	4-95
Service Brake Shoe Assemblies: M967, M969, M970 except M970 SN TC-0843, TC-0844, and TC-103 thru TC-178 .....	4-33	4-80
M967A1, M969A1, and M970A1 including M970 SN TC-0843, TC-0844, and TC-103 thru TC-178 .....	4-34	4-82
Shoe, Landing Gear .....	4-54	4-112
Shoes, Brake .....	6-6	6-4
Shrouding, Air Cooling .....	7-14,7-60	7-11,7-35
Slack Adjuster (M967A1, M969A1, M970A1 including M970 SN TC-0843, TC-0844, and TC-103 thru TC-178) .....	4-41	4-92
Solenoid, Engine Preheater .....	4-18	4-52
Solenoid, Fuel Stop .....	7-20,7-54	7-16,7-34
	7-67,7-85	7-39,7-63
Solenoid, Starter .....	4-80	4-136
Spare Wheel Carrier .....	4-53	4-112
Specifications and Tolerances .....	7-10	7-7
Tabulated Data .....	7-10	7-7
Torque Specifications .....	7-10	7-7

INDEX-Continued

	Paragraph	Page
Splash Plates, Brackets, Mudflaps, and .....	4-56	4-114
Spring Seat Bearings (M967, M969, M970 except M970 SN TC-0843, TC-0844, and TC-103 thru TC-178) .....	4-30	4-74
Spring Seat Bearings, Wiper, and Seals (M967, M969, and M970 except M970 SN TC-0843, TC0844, and TC-103 thru TC-178) .....	6-3	6-1
Starter Assembly .....	7-78	7-55
Starter Motor .....	4-79	4-134
Starter Solenoid .....	4-80	4-136
Starting System .....	7-6	7-4
Starter Tests .....	7-90	7-70
Static Reel .....	4-96	4-164
Stenciling, Painting and .....	4-7	4-22
Strainer, Piping .....	4-87	4-150
Sump Components .....	4-84	4-141
Automatic Drain Valve and Float Assembly .....	4-84	4-141
Manual Drain Valve .....	4-84	4-141
Sump, Filter/Separator .....	3-12	3-36
Suspension (M967A1, M969A1, and M970A1 including M970 SN TC-0843, TC-0844, and TC-103 thru TC-174) .....	5-13	5-17
Suspension Springs (M967, M969, and M970 except M970 SN TC-0843, TC-0844, and TC-103 thru TC-174) .....	5-12	5-15
Switch, High Temperature .....	7-17,7-57,7-83	7-13,7-34,7-63
Bench Test Armature .....	7-90	7-70
for Grounds .....	7-90	7-71
for Open Coils .....	7-90	7-71
for Shorted Cods .....	7-90	7-71
Shaft Runout .....	7-90	7-71
Bench Test Brush Springs .....	7-90	7-72
Bench Test Commutator Runout .....	7-90	7-71
Bench Test Field Coils .....	7-90	7-71
Bench Test Solenoid Switch .....	7-90	7-72
On Equipment Test .....	4-79,7-90	4-134,7-70
Switches, Gages, and Indicator Light .....	4-24	4-59
Preheat Indicator Light .....	4-24	4-65
Preheat Indicator Light Lamp .....	4-24	4-65
Wiring .....	4-24	4-65
Control Panel Plate .....	4-24	4-65
Switches, Instruments and Indicator Light .....	4-24	4-60
Testing Instruments, Switches, and Indicator Light .....	4-24	4-59
Engine Switches (Preheater, Starter, and Engine) .....	4-24	4-60
Filter/Separator Gage .....	4-24	4-62
Fuel Pressure and/or Oil Pressure Gages .....	4-24	4-62
Tachometer and/or Hourmeter .....	4-24	4-61
Voltmeter and/or Pump Pressure Gage .....	4-24	4-61

**T**

Tabulated Data .....	1-10	1-13
Tachometer Recalibration .....	7-82	7-63

INDEX-Continued

	<b>Paragraph</b>	<b>Page</b>
Tachometer Sensor (M967, M969, and M970) . . . . .	7-16,7-58	7-13,7-35
Tank Body . . . . .	4-59	4-119
Tank, Draining . . . . .	4-100	4-167
Tank Components . . . . .	6-19	6-12
Tank, Purging . . . . .	4-101	4-167
Tappets, Camshaft and . . . . .	7-34,7-40	7-25,7-30
Terminals, Cables, Batteries, and . . . . .	3-6,4-23	3-34,4-56
Throttle Cable, Engine . . . . .	4-75	4-126
Throttle Linkage, Engine . . . . .	4-75	4-125
Tire and Tube . . . . .	4-50	4-109
Tool Box . . . . .	3-11,4-58	3-36,4-118
<b>Torque Rods, Upper and Lower (M967, M699, and M970 except M970 SN TC-0843, TC-0844, and TC-103 thru TC-178) . . . . .</b>	<b>5-11</b>	<b>5-14</b>
<b>Troubleshooting</b>		
Direct Support . . . . .	5-4	5-3
General support . . . . .	5-4	5-10
Operator/Crew . . . . .	3-4	3-28
Unit . . . . .	4-6	4-9
<b>Trunnion Cross Tube</b>		
M967, M969, and M970 except M970 SN TC-0843, TC-0844, and TC-103 thru TC-178 . . . . .	6-4	6-2
M967A1, M969A1, and M970A1 including M970 SN TC-0843, TC-0844, and TC-103 thru TC-178 . . . . .	6-5	6-3
Tube, Oil Filter . . . . .	7-23,7-51	7-16,7-34
Tubing, Control . . . . .	4-92	4-153
<b>U</b>		
Uncoupling Semitrailer from Towing Vehicle . . . . .	2-6	2-5
Underwing Nozzle (M970 and M970A1) . . . . .	3-17,8-24	3-39,8-34
Unusual Terrain, Operation on . . . . .	2-23	2-53
Upper Coupler/Kingpin Assembly . . . . .	4-52	4-110
Upper Coupler (Kingpin) Plate Replacement . . . . .	5-10	5-14
Using the DC Volts Scale . . . . .	4-11	4-34
Measuring DC Voltage . . . . .	4-11	4-35
Setting Up the Meter . . . . .	4-11	4-34
AN/URM-105 . . . . .	4-11	4-34
Simpson 160 . . . . .	4-11	4-34
TS 352 BU . . . . .	4-11	4-34
Using the Ohms Scale . . . . .	4-10	4-30
Continuity Test . . . . .	4-10	4-31
Testing for Shorts . . . . .	4-10	4-32
Testing Resistance . . . . .	4-10	4-33
Zero the Meter . . . . .	4-10	4-30
AN/URM-105 . . . . .	4-10	4-30
Simpson 160 . . . . .	4-10	4-31
TS 352 BU . . . . .	4-10	4-30

INDEX-Continued

	Paragraph	Page
Valve Rocker Arm Adjustment .....	7-88	7-69
Valves .....	4-48,4-86	4-98,4-142
Angle Valve and Check Valve (M969, M969A1, M970, and M970A1) .....	4-86,8-15	4-143,8-24
Butterfly Valve .....	4-86,8-13	4-143,8-22
Check Valve (M697, M967A1, M969, and M969A1) .....	4-86,8-14	4-144,8-23
Deadman Control Valve (M970 and M970A1) .....	8-21	8-32
Deadman Release Valve .....	4-94	4-163
Emergency Relay Valve .....	4-44	4-95
Emergency Valve .....	4-86,8-20	4-148,8-31
Four-inch Control Valve (Bottom Loading) .....	4-86	4-144
Gate Valves .....	4-86	4-142
Manifold Drain Valve .....	8-17	8-26
Oil Bypass Valve .....	7-74	7-53
Parking Brake Control Valve .....	4-47	4-97
Precheck and/or Load/Unload Valve .....	4-93	4-163
Pressure Protection Valve .....	4-46	4-96
Pump Bypass Valve (M970 and M970A1) .....	4-86,8-16	4-149,8-25
Three-inch Control Valve (Deadman Valve) (M970 and M970A1) .....	4-86	4-146
Vapor Recovery Kit .....	1-9	1-13
Vapor Recovery Piping .....	4-98	4-165
Ground Receptacle .....	4-98	4-165
Vapor Recovery Hood and Hose .....	4-98	4-165
Vehicle Nozzle (M969 and M969A1) .....	3-14,4-97	3-36,4-165
Vehicle Nozzle .....	8-22	8-33

W

Wheels, Hubs, and Drums .....	4-49	4-101
Installation and Adjustment as an Assembly		
M967, M969, and M970 except M970 SN TC-0843, TC-0844, and TC-103 thru TC-178 .....	4-49	4-104
M967A1, M969A1, and M970A1 including M970 SN TC-0843 TC-0844, and TC-103 thru TC-178 .....	4-49	4-108
Removal as an Assembly:		
M967, M969, and M970 except M970 SN TC-0843, TC-0844, and TC-103 thru TC-178 .....	4-49	4-101
M967A1, M969A1, and M970A1 including M970 SN TC-0843, TC-0844, and TC-103 thru TC-178 .....	4-49	4-105
Tire and Wheel Replacement .....	4-49	4-101
Wheel Bearings:		
M967, M969, and M970 except M970 SN TC-0843, TC-0844, and TC-103 thru TC-178 .....	4-49	4-104
M967A1, M969A1, and M970A1 including M970 SN TC-0843, TC-0844, and TC-103 thru TC-178 .....	4-49	4-106
Wheel Studs:		
M967, M969, and M970 except M970 SN TC-0843, TC-0844, and TC-103 thru TC-178 .....	4-49	4-109
M967A1, M969A1, and M970A1 including M970 SN TC-0843, TC-0844, and TC-103 thru TC-178 .....	4-49	4-109

INDEX-Continued

---

	<b>Paragraph</b>	<b>Page</b>
Wiring, Chassis .....	4-12	4-36
Wiring, Engine .....	4-16	4-45
Wiring Harness and Conduit, Control Panel .....	4-25	4-65
Wiring, Hose Reel .....	4-27	4-68





By Order of the Secretary of the Army:

CARL E. VUONO  
General, United States Army  
Chief of Staff

Official:

THOMAS F. SIKORA  
Brigadier General, United States Army  
The Adjutant General

Distribution:

To be distributed in accordance with DA Form 12-37-E (Block 1560) Direct Support and General Support maintenance requirements for TM9-2330-356-14.

\*U.S. GOVERNMENT PRINTING OFFICE: 1990 543-016/40001



RECOMMENDED CHANGES TO EQUIPMENT TECHNICAL PUBLICATIONS



THEN... JOT DOWN THE DOPE ABOUT IT ON THIS FORM. CAREFULLY TEAR IT OUT. FOLD IT AND DROP IT IN THE MAIL!

**SOMETHING WRONG WITH THIS PUBLICATION?**

FROM: (PRINT YOUR UNIT'S COMPLETE ADDRESS)

DATE SENT

PUBLICATION NUMBER  
TM 9-2330-356-14

PUBLICATION DATE  
26 October 1990

PUBLICATION TITLE Operator's, Org., DS/GS Maintenance for Semitrailer, Tank, Models M967, M967A1, M969, M969A1, M970, M970A1

BE EXACT PIN-POINT WHERE IT IS

PAGE NO	PARA-GRAPH	FIGURE NO	TABLE NO

IN THIS SPACE TELL WHAT IS WRONG AND WHAT SHOULD BE DONE ABOUT IT:

PRINTED NAME GRADE OR TITLE AND TELEPHONE NUMBER

SIGN HERE

FILL IN YOUR  
UNIT'S ADDRESS

FOLD BACK

DEPARTMENT OF THE ARMY

Co. B 1st Bn, 2d Bde

Ft. Hood, TX 76544

OFFICIAL BUSINESS  
PENALTY FOR PRIVATE USE \$300

Commander  
US Army Tank-Automotive Command  
ATTN: AMSTA-MB  
Warren, Michigan 48397-5000

**SAMPLE**

TEAR ALONG PERFORATED LINE

RECOMMENDED CHANGES TO EQUIPMENT TECHNICAL PUBLICATIONS



THEN... JOT DOWN THE DOPE ABOUT IT ON THIS FORM. CAREFULLY TEAR IT OUT. FOLD IT AND DROP IT IN THE MAIL!

**SOMETHING WRONG WITH THIS PUBLICATION?**

FROM: (PRINT YOUR UNIT'S COMPLETE ADDRESS)

Co. B, 1st Bn., 2d Bde  
Ft. Hood, TX 76544

DATE SENT

15 December 90

PUBLICATION NUMBER

TM 9-2330-356-14

PUBLICATION DATE

PUBLICATION TITLE Operator's, Org., DS/GS Maintenance for Semitrailer, Tank, Models M967, M967A1, M969, M969A1, M970, M970A1

BE EXACT. PIN-POINT WHERE IT IS

PAGE NO	PARA-GRAPH	FIGURE NO	TABLE NO
2-45	2-18f		
6-7	6-16d		

IN THIS SPACE TELL WHAT IS WRONG AND WHAT SHOULD BE DONE ABOUT IT:

Steps (4) and (5) are out of sequence. They should be reversed.

In Step (1), Callout for nut (6) is incorrect. Callout number should be (10).

**SAMPLE**

PRINTED NAME, GRADE OR TITLE AND TELEPHONE NUMBER

John M. Doe, SPA, AV589-0639

SIGN HERE

John M. Doe, SPA

FILL IN YOUR  
UNIT'S ADDRESS

FOLD BACK

DEPARTMENT OF THE ARMY

TEAR ALONG PERFORATED LINE

OFFICIAL BUSINESS  
PENALTY FOR PRIVATE USE \$300

Commander  
US Army Tank-Automotive Command  
ATTN: AMSTA-MB  
Warren, Michigan 48397-5000

RECOMMENDED CHANGES TO EQUIPMENT TECHNICAL PUBLICATIONS



## SOMETHING WRONG WITH THIS PUBLICATION?

FROM: (PRINT YOUR UNIT'S COMPLETE ADDRESS)

DATE SENT

PUBLICATION NUMBER  
**TM 9-2330-356-14**

PUBLICATION DATE  
**26 October 1990**

PUBLICATION TITLE **Operator's, Org., DS/GS Maintenance for Semitrailer, Tank, Models M967, M967A1, M969, M969A1, M970, M970A1**

BE EXACT PIN-POINT WHERE IT IS				IN THIS SPACE TELL WHAT IS WRONG AND WHAT SHOULD BE DONE ABOUT IT:
PAGE NO	PARA-GRAPH	FIGURE NO	TABLE NO	

PRINTED NAME, GRADE OR TITLE AND TELEPHONE NUMBER

SIGN HERE

FILL IN YOUR  
UNIT'S ADDRESS



FOLD BACK

DEPARTMENT OF THE ARMY

TEAR ALONG PERFORATED LINE

OFFICIAL BUSINESS  
PENALTY FOR PRIVATE USE \$300

Commander  
US Army Tank-Automotive Command  
ATTN: AMSTA-MB  
Warren, Michigan 48397-5000



RECOMMENDED CHANGES TO EQUIPMENT TECHNICAL PUBLICATIONS



THEN... JOT DOWN THE DOPE ABOUT IT ON THIS FORM. CAREFULLY TEAR IT OUT. FOLD IT AND DROP IT IN THE MAIL!

**SOMETHING WRONG WITH THIS PUBLICATION?**

FROM: (PRINT YOUR UNIT'S COMPLETE ADDRESS)

DATE SENT

PUBLICATION NUMBER

TM 9-2330-356-14

PUBLICATION DATE

26 October 1990

PUBLICATION TITLE Operator's, Org., DS/GS Maintenance for Semitrailer, Tank, Models M967, M967A1, M969, M969A1, M970, M970A1

BE EXACT. PIN-POINT WHERE IT IS

PAGE NO

PARA-GRAPH

FIGURE NO

TABLE NO

IN THIS SPACE TELL WHAT IS WRONG AND WHAT SHOULD BE DONE ABOUT IT:

PRINTED NAME, GRADE OR TITLE, AND TELEPHONE NUMBER

SIGN HERE

FILL IN YOUR  
UNIT'S ADDRESS



FOLD BACK

DEPARTMENT OF THE ARMY



OFFICIAL BUSINESS  
PENALTY FOR PRIVATE USE \$300

Commander  
US Army Tank-Automotive Command  
ATTN: AMSTA-MB  
Warren, Michigan 48397-5000

TEAR ALONG PERFORATED LINE

## THE METRIC SYSTEM AND EQUIVALENTS

### LINEAR MEASURE

1 Centimeter = 10 Millimeters = 0.01 Meters = 0.3937 Inches  
 1 Meter = 100 Centimeters = 1000 Millimeters = 39.37 Inches  
 1 Kilometer = 1000 Meters = 0.621 Miles

### WEIGHTS

1 Gram = 0.001 Kilograms = 1000 Milligrams = 0.035 Ounces  
 1 Kilogram = 1000 Grams = 2.2 Lb  
 1 Metric Ton = 1000 Kilograms = 1 Megagram = 1.1 Short Tons

### LIQUID MEASURE

1 Milliliter = 0.001 Liters = 0.0338 Fluid Ounces  
 1 Liter = 1000 Milliliters = 33.82 Fluid Ounces

### SQUARE MEASURE

1 Sq. Centimeter = 100 Sq. Millimeters = 0.155 Sq. Inches  
 1 Sq. Meter = 10,000 Sq. Centimeters = 10.76 Sq. Feet  
 1 Sq. Kilometer = 1,000,000 Sq. Meters = 0.386 Sq. Miles

### CUBIC MEASURE

1 Cu. Centimeter = 1000 Cu. Millimeters = 0.06 Cu. Inches  
 1 Cu. Meter = 1,000,000 Cu. Centimeters = 35.31 Cu. Feet

### TEMPERATURE

$5/9 (^{\circ}\text{F} - 32) = ^{\circ}\text{C}$   
 $212^{\circ}\text{ Fahrenheit is equivalent to } 100^{\circ}\text{ Celsius}$   
 $90^{\circ}\text{ Fahrenheit is equivalent to } 32.2^{\circ}\text{ Celsius}$   
 $32^{\circ}\text{ Fahrenheit is equivalent to } 0^{\circ}\text{ Celsius}$   
 $9/5 \text{ C}^{\circ} + 32 = \text{F}^{\circ}$

### APPROXIMATE CONVERSION FACTORS

TO CHANGE	TO	MULTIPLY BY
Inches . . . . .	Centimeters . . . . .	2.540
Feet . . . . .	Meters . . . . .	0.305
Yards . . . . .	Meters . . . . .	0.914
Miles . . . . .	Kilometers . . . . .	1.609
Square Inches . . . . .	Square Centimeters . . . . .	6.451
Square Feet . . . . .	Square Meters . . . . .	0.093
Square Yards . . . . .	Square Meters . . . . .	0.836
Square Miles . . . . .	Square Kilometers . . . . .	2.590
Acres . . . . .	Square Hectometers . . . . .	0.405
Cubic Feet . . . . .	Cubic Meters . . . . .	0.028
Cubic Yards . . . . .	Cubic Meters . . . . .	0.765
Fluid Ounces . . . . .	Milliliters . . . . .	29.573
Pints . . . . .	Liters . . . . .	0.473
Quarts . . . . .	Liters . . . . .	0.946
Gallons . . . . .	Liters . . . . .	3.785
Ounces . . . . .	Grams . . . . .	28.349
Pounds . . . . .	Kilograms . . . . .	0.454
Short Tons . . . . .	Metric Tons . . . . .	0.907
Pound-Feet . . . . .	Newton-Meters . . . . .	1.356
Pounds per Square Inch . . . . .	Kilopascals . . . . .	6.895
Miles per Gallon . . . . .	Kilometers per Liter . . . . .	0.425
Miles per Hour . . . . .	Kilometers per Hour . . . . .	1.609

TO CHANGE	TO	MULTIPLY BY
Centimeters . . . . .	Inches . . . . .	0.393
Meters . . . . .	Feet . . . . .	3.280
Meters . . . . .	Yards . . . . .	1.094
Kilometers . . . . .	Miles . . . . .	0.621
Square Centimeters . . . . .	Square Inches . . . . .	0.155
Square Meters . . . . .	Square Feet . . . . .	10.764
Square Meters . . . . .	Square Yards . . . . .	1.196
Square Kilometers . . . . .	Square Miles . . . . .	0.386
Square Hectometers . . . . .	Acres . . . . .	2.471
Cubic Meters . . . . .	Cubic Feet . . . . .	35.315
Cubic Meters . . . . .	Cubic Yards . . . . .	1.308
Milliliters . . . . .	Fluid Ounces . . . . .	0.034
Liters . . . . .	Pints . . . . .	2.113
Liters . . . . .	Quarts . . . . .	1.057
Liters . . . . .	Gallons . . . . .	0.264
Grams . . . . .	Ounces . . . . .	0.035
Kilograms . . . . .	Pounds . . . . .	2.205
Metric Tons . . . . .	Short Tons . . . . .	1.102
Newton-Meters . . . . .	Pound-Feet . . . . .	0.738
Kilopascals . . . . .	Pounds per Square Inch . . . . .	0.145
Kilometers per Liter . . . . .	Miles per Gallon . . . . .	2.354
Kilometers per Hour . . . . .	Miles per Hour . . . . .	0.621

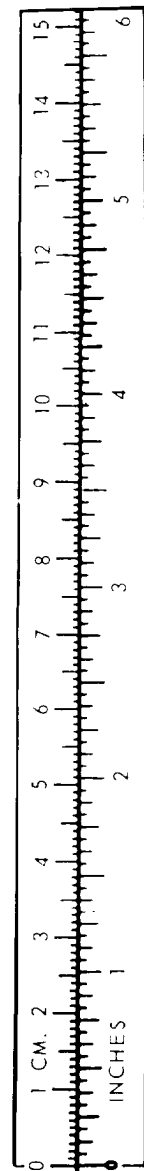

TAO89991

